

Title	On Dijkgraaf-Witten invariant for 3-manifolds
Author(s)	Wakui, Michihisa
Citation	Osaka Journal of Mathematics. 1992, 29(4), p. 675-696
Version Type	VoR
URL	<a href="https://doi.org/10.18910/11650">https://doi.org/10.18910/11650</a>
rights	
Note	

*Osaka University Knowledge Archive : OUKA*

<https://ir.library.osaka-u.ac.jp/>

Osaka University

## ON DIJKGRAAF-WITTEN INVARIANT FOR 3-MANIFOLDS

MICHIHISA WAKUI

(Received September 17, 1991)

### 1. Introduction

In 1990 Dijkgraaf and Witten [4] introduced a method of constructing an invariant of 3-manifolds using a finite gauge group  $G$ . For a closed oriented 3-manifold  $M$ , the Dijkgraaf-Witten invariant is given by the following formula:

$$Z(M) = \frac{1}{|G|} \sum_{\gamma \in \text{Hom}(\pi_1(M), G)} \langle \gamma^* \alpha, [M] \rangle .$$

Here  $\gamma$  is a continuous map from a closed 3-manifold  $M$  to the classifying space  $BG$  of  $G$ ,  $\alpha$  is a cohomology class of  $H^3(BG, U(1))$ ,  $\gamma^*$  is a map from  $H^3(BG, U(1))$  to  $H^3(M, U(1))$  induced from  $\gamma$  and  $[M]$  is the fundamental class of  $M$ . However, in the case where  $M$  has a boundary, such a formulation can not be done, because the fundamental class  $[M]$  is not defined for a manifold with boundary. To extend the definition of  $Z(M)$  to a 3-manifold with boundary, they reduced the topological action  $\langle \gamma^* \alpha, [M] \rangle$  to a lattice gauge theory. Furthermore Dijkgraaf and Witten asserted that their construction for a 3-manifold with boundary gives an example of a topological quantum field theory.

In this paper, we formulate an invariant of 3-manifolds possibly with boundary introduced by Dijkgraaf and Witten using a triangulation and prove its topological invariance in a rigorous way. Once given a finite group  $G$  and a 3-cocycle  $\alpha \in Z^3(BG, U(1))$ , the Dijkgraaf-Witten invariant is defined combinatorially. Throughout this paper, our target manifolds are compact oriented 3-manifolds with boundary or without boundary.

By a colour of  $M$ , we mean a map assigning an element of  $G$  to each oriented edge of a triangulated compact oriented 3-manifold  $M$  under some condition (See §2, for more precise definition). We call a map obtained from a colour of  $M$  by restricting it, to the oriented edges in  $\partial M$  a colour of  $\partial M$ . For a colour  $\tau$  of  $\partial M$ , by  $\text{Col}(M, \tau)$  we denote the set of all colours of  $M$  which are equal to  $\tau$ , when restricted to  $\partial M$ . Having a colour  $\varphi$  of  $M$  we associate with each 3-simplex  $\sigma$  of  $M$  a complex number  $W(\sigma, \varphi) \in U(1)$  using  $\alpha$ . We

denote the number of vertices of  $M$  by  $a$ . Let  $\sigma_1, \dots, \sigma_n$  be all the 3-simplices of  $M$ . For a colour  $\tau$  of  $\partial M$ , the Dijkgraaf-Witten invariant is given by the following formula:

$$Z_M(\tau) = \frac{1}{|G|^a} \sum_{\varphi \in \text{Col}(M, \tau)} \prod_{i=1}^n W(\sigma_i, \varphi)^{\varepsilon_i},$$

where

$$\varepsilon_i = \begin{cases} 1 & \text{if the orientation for } \sigma_i \text{ is compatible with that for } M, \\ -1 & \text{otherwise.} \end{cases}$$

The invariant has the following two properties:

- (1) For a closed oriented 3-manifold  $M$  we have  $Z(-M) = \overline{Z(M)}$ , where  $-M$  is the closed oriented 3-manifold with the opposite orientation.
- (2) For closed oriented 3-manifolds  $M_1, M_2$  we have  $\frac{1}{|G|} Z(M_1 \# M_2) = Z(M_1)Z(M_2)$ , where  $M_1 \# M_2$  is the connected sum of  $M_1$  and  $M_2$ .

Turaev and Viro[11] defined combinatorially an invariant of a 3-manifold associated with quantum  $6j$ -symbols. In order to prove the topological invariance of their invariant, they showed a relative version of a theorem of Alexander [1] on equivalence of triangulations. We use the theorem showed by Turaev and Viro in order to prove the topological invariance of the Dijkgraaf-Witten invariant.

However, Turaev and Viro do not directly use this theorem for their proof of the topological invariance of their invariant. They proved it by translating thie invariant into an invariant of a simple 2-polyhedron  $X$  obtained from a dual cell subdivision of a triangulated compact 3-manifold  $M$ . To carry out this, they introduced 3-type moves on simple 2-polyhedra. These 3-type moves were essentially considered by S. Matveev [6]. Since these 3-type moves are natural with respect to orientations for  $X$  or  $M$ , we can also prove the topological invariance of the Dijkgraaf-Witten invariant using this dual approach. From these facts, we can compute the Dijkgraaf-Witten invariant using a singular triangulation[11]. We describe some examples for calculations on the Dijkgraaf-Witten invariant using a singular triangulation.

Atiyah[2] defined mathematically an axiom for a topological quantum field theory. We show that the construction of the Dijkgraaf-Witten invariant of a 3-manifold with boundary gives an example of the topological quantum field theory. However, we have to modify slightly Dijkgraaf and Witten's definition in order to satisfy the axiom for the topological quantum field theory. Finally by means of Turaev and Viro's method, we construct a representation of isotopy classes of orientation preserving homeomorphisms of an oriented closed surface.

This paper is organized in the following way. In section 2, we introduce the definition of the Dijkgraaf-Witten invariant for 3-manifolds. In section

3, we prove the topological invariance of the Dijkgraaf-Witten invariant. In section 4, we explain a dual approach on the Dijkgraaf-Witten invariant and present some examples for calculations on the Dijkgraaf-Witten invariant, in particular for the case of the lens space  $L(p, 1)$ . Furthermore we construct a 2-dimensional topological quantum field theory associated with the Dijkgraaf-Witten invariant and a representation of the mapping class group of an oriented closed surface.

ACKNOWLEDGEMENT: I am deeply indebted to Professor T. Kohno for useful suggestions and advice. During the preparation of this article, Professor I. Ishii furnished me with valuable information on Matveev's work, and I would like to thank him. Thanks are also due to Professor M. Kato for helpful conversation and encouragement.

## 2. Definition of Dijkgraaf-Witten Invariant

First we describe our initial data which will be used to define an invariant of triangulated compact oriented 3-manifolds. Let us recall group cohomologies [3]. Let  $G$  be a finite group and  $V$  a multiplicative abelian group. We denote the set of all maps

$$f: \underbrace{G \times \cdots \times G}_{n \text{ times}} \rightarrow V$$

by  $C^n(G, V)$ . In a natural way, the set  $C^n(G, V)$  has a structure of an abelian group. We define a coboundary operator  $\delta^n: C^n(G, V) \rightarrow C^{n+1}(G, V)$  by the following formula:

$$\begin{aligned} (\delta^n f)(x_1, \dots, x_{n+1}) \\ = f(x_2, \dots, x_{n+1}) \prod_{i=1}^n f(x_1, \dots, x_i x_{i+1}, \dots, x_{n+1})^{(-1)^i} f(x_1, \dots, x_n)^{(-1)^{n+1}}, \end{aligned}$$

where  $f \in C^n(G, V)$  and  $x_1, \dots, x_{n+1} \in G$ . The quotient group  $\text{Ker } \delta^n / \text{Im } \delta^{n-1}$  is called the  $n$ -th cohomology group of  $G$  with coefficients in  $V$ , and denoted by  $H^n(G, V)$ . For any finite group  $G$ , we denote the classifying space of  $G$  by  $BG$ . Here we use a semi-simplicial theoretical method [7] to construct  $BG$ , which is introduced by Eilenberg and Zilber [5].

Now we take the unitary group  $U(1) = \mathbf{R}/\mathbf{Z}$  as an abelian group  $V$ . Then we define a map  $\psi: \text{Hom}(C_n(BG, \mathbf{Z}), U(1)) \rightarrow C^n(G, U(1))$  by

$$\psi(\alpha)(g_1, \dots, g_n) = \alpha([g_1 | \cdots | g_n]),$$

where  $C_n(BG, \mathbf{Z})$  is the relative homology group  $H_n(K_n, K_{n-1}; \mathbf{Z})$  of the semi-simplicial complex  $K$  with  $n$ -skeleton  $K_n$  defining the classifying space  $BG$  and  $[g_1 | \cdots | g_n]$  is the  $n$ -cell defined by  $g_1, \dots, g_n \in G$ . Then we easily see that  $\psi$  is a cochain map and induces an isomorphism from the cohomology group

$H^n(BG, U(1))$  to  $H^n(G, U(1))$ . By the map  $\psi$ , we often identify  $\alpha([g_1 | \cdots | g_n])$  with  $\psi(\alpha)(g_1, \dots, g_n)$  and denote it by  $\alpha(g_1, \dots, g_n)$ .

Next we introduce the Dijkgraaf-Witten invariant. Let  $G$  be a finite group. We fix a 3-cocycle  $\alpha \in Z^3(BG, U(1))$ . Let  $M$  be a compact oriented triangulated 3-manifold. By a colour of  $M$ , we mean a map

$$\varphi: \{\text{the oriented edges of } M\} \rightarrow G$$

which satisfies the following two conditions:

- (1) For any 'oriented' 2-simplex  $F$ , we have  $\varphi(\partial F) = 1$ . Here the symbol  $\partial F$  stands for the image of  $F$  under the boundary operator  $\partial$ , when we regard  $F$  as a generator of the chain group  $C_2(M; \mathbf{Z})$ . (See Fig. 1)
- (2) For any oriented edge  $E$ , we have  $\varphi(-E) = \varphi(E)^{-1}$ , where  $-E$  is the oriented edge with the opposite orientation.

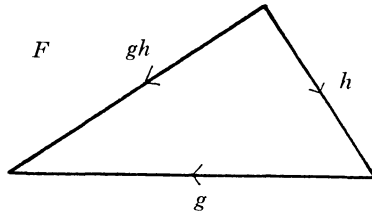

Fig. 1

If a map  $\tau: \{\text{the oriented edges of } \partial M\} \rightarrow G$  satisfies, again, the above conditions (1) and (2), then we call  $\tau$  a colour of  $\partial M$ . We denote the set of all colours of  $M$  and  $\partial M$  by  $\text{Col}(M)$  and  $\text{Col}(\partial M)$ , respectively. Furthermore, given  $\tau \in \text{Col}(\partial M)$ , by  $\text{Col}(M, \tau)$  we denote the set of all colours of  $M$  which are equal to  $\tau$ , when restricted to  $\partial M$ .

Now we give an order to the set of the vertices of  $M$ , and then in each 3-simplex  $\sigma_i$ , we give an order to the vertices in the ascending order. Let us give the orientation of each 3-simplex  $\sigma_i$  in the ascending order. Let  $\varphi$  be a colour of  $M$  and  $\sigma$  a 3-simplex of  $M$ . If  $\sigma = |a_0 a_1 a_2 a_3|$  ( $a_0 < a_1 < a_2 < a_3$ ) and  $\varphi(\langle a_0, a_1 \rangle) = g$ ,  $\varphi(\langle a_2, a_3 \rangle) = h$  and  $\varphi(\langle a_2, a_3 \rangle) = k$ , then we put

$$W(\sigma, \varphi) = \alpha([g | h | k]) \in U(1).$$

The Dijkgraaf-Witten invariant is described as follows.

**Theorem.** *Let  $G$  be a finite group. We fix a 3-cocycle  $\alpha \in Z^3(BG, U(1))$ . Let  $M$  be a compact oriented triangulated 3-manifold. We denote the number of vertices of  $M$  by  $a$ . Let  $\sigma_1, \dots, \sigma_n$  be all the 3-simplices of  $M$ . Given  $\tau \in \text{Col}(\partial M)$ , we define the Dijkgraaf-Witten invariant by*

$$Z_M(\tau) = \frac{1}{|G|^a} \sum_{\varphi \in \text{Col}(M, \tau)} \prod_{i=1}^n W(\sigma_i, \varphi)^{\varepsilon_i}$$

where

$$\varepsilon_i = \begin{cases} 1 & \text{if the orientation for } \sigma_i \text{ is compatible with that for } M, \\ -1 & \text{otherwise.} \end{cases}$$

Then  $Z_M(\tau)$  does not depend on the choice of triangulation of  $M$  and the choice of order of vertices in  $M$  whenever we fix a triangulation of  $\partial M$  and  $\tau$ .

REMARK. If a given 3-cocycle  $\alpha$  is trivial, then  $Z_M(\tau) = \frac{1}{|G|^a} \# \text{Col}(M, \tau)$ .

Thus if  $M$  is connected,  $Z_M(\tau)$  is equal to the number of representations of  $\pi_1(M)$  over  $G$  which are equal to  $\tau$  on  $\pi_1(\partial M)$ , up to the factor  $\frac{1}{|G|}$  :

$$Z_M(\tau) = \frac{1}{|G|} \# \{ \rho : \pi_1(M) \rightarrow G \mid \rho \text{ is a representation of } \pi_1(M) \text{ and } \rho \circ i_* = \tau \},$$

where  $i_*$  is the homomorphism of fundamental groups induced from the inclusion  $i : \partial M \hookrightarrow M$ .

### 3. Proof of the Main Theorem

We divide a proof of the main theorem into two parts. First we show the independence of the choice of order of vertices of  $M$ .

**Lemma 3.1.** *The complex number  $Z_M(\tau)$  does not depend on the choice of order of vertices in  $M$ .*

Proof. Given any 3-simplex  $\sigma = |a_0 a_1 a_2 a_3|$  of  $M$  and any colour  $\varphi$  of  $M$ , it is sufficient to prove the following identity:

$$(3.1) \quad \begin{aligned} & \alpha([\varphi(\langle a_0, a_1 \rangle) | \varphi(\langle a_1, a_2 \rangle) | \varphi(\langle a_2, a_3 \rangle)]) \\ & = \alpha([\varphi(\langle a_{i_0}, a_{i_1} \rangle) | \varphi(\langle a_{i_1}, a_{i_2} \rangle) | \varphi(\langle a_{i_2}, a_{i_3} \rangle)])^{-1} \end{aligned}$$

for  $(i_0, i_1, i_2, i_3) = (1, 0, 2, 3), (0, 2, 1, 3)$  and  $(0, 1, 3, 2)$ .

We consider  $(i_0, i_1, i_2, i_3) = (1, 0, 2, 3)$ . We put  $g = \varphi(\langle a_0, a_1 \rangle)$ ,  $h = \varphi(\langle a_1, a_2 \rangle)$  and  $k = \varphi(\langle a_2, a_3 \rangle)$ . We show that  $\alpha([g | h | k]) = \alpha([g^{-1} | gh | k])^{-1}$ . We take a 4-cell  $[g | g^{-1} | h | k]$  in  $BG$ . Then since

$$\partial[g^{-1} | g | h | k] = [g | h | k] - [1 | h | k] + [g^{-1} | gh | k] - [g^{-1} | g | hk] + [g^{-1} | g | h]$$

and

$$\begin{aligned} [1 | h | k] &= [g^{-1} | g | hk] = [g^{-1} | g | h] = 0 \text{ in } C_3(BG, \mathbf{Z}), \\ [g^{-1} | g | h | k] &= 0 \text{ in } C_4(BG, \mathbf{Z}). \end{aligned}$$

So we have that  $[g | h | k] = -[g^{-1} | gh | k]$  in  $C_3(BG, \mathbf{Z})$ . Thus it is proved that

$$\alpha([g|h|k]) = \alpha([g^{-1}|gh|k])^{-1}.$$

In the same manner, we can prove the equation (3.1) in other cases. This completes the proof.

Next we show that  $Z_M(\tau)$  does not depend on the choice of triangulation of  $M$  when we fix a triangulation of  $\partial M$ . We use a theorem showed by Turaev and Viro [11] which is a relative version of a theorem of Alexander [1].

**Theorem 3.1. (Turaev-Viro).** *Let  $P$  be a dimensionally homogeneous polyhedron and  $Q$  its subpolyhedron. Any two triangulation of  $P$  coinciding on  $Q$  can be transformed one to another by a sequence of Alexander moves and transformations inverse to Alexander moves, which do not change the triangulation of  $Q$ .*

Here by an Alexander move, we mean a star subdivision of a triangulation of a polyhedron.

**Lemma 3.2.** *Let  $M$  be a compact oriented triangulated 3-manifold. Then for any  $\tau \in \text{Col}(\partial M)$ , the complex number  $Z_M(\tau)$  is invariant under the Alexander move along an open 3-simplex.*

*Proof.* Let  $T$  be a given triangulation of  $M$  and  $T'$  a triangulation of  $M$  obtained from  $T$  by the Alexander move along an open 3-simplex  $\sigma = |v_0v_1v_2v_3|$  of  $T$ . Let  $a$  be the number of vertices of  $T$ . Let  $v_0, v_1, v_2, v_3, v_5, \dots, v_a$  be the vertices of  $T$  and  $v_4$  the new vertex of  $T'$  added to  $T$ . We give an order to the vertices of  $T$  such that

$$v_0 < v_1 < v_2 < v_3 < v_5 < \dots < v_a,$$

and to the vertices of  $T'$  such that

$$v_0 < v_1 < v_2 < v_3 < v_4 < v_5 < \dots < v_a.$$

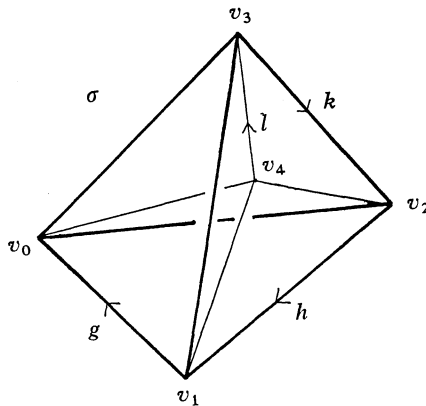

Fig. 2

We denote new 3-simplices  $|v_1v_2v_3v_4|$ ,  $|v_0v_2v_3v_4|$ ,  $|v_0v_1v_3v_4|$  and  $|v_0v_1v_2v_4|$  of  $T'$  by  $\sigma_0, \sigma_1, \sigma_2$  and  $\sigma_3$ , respectively. For any  $\varphi \in \text{Col}(T, \tau)$  and any  $l \in G$ , there is a unique colour  $\varphi_l$  of  $T'$  such that it is equal to  $\varphi$  on  $M - \text{Int}\sigma$  and  $\varphi_l(\langle v_3, v_4 \rangle) = l$ .

Therefore, it is sufficient to prove that

$$(3.2) \quad W(\sigma, \varphi)^{\varepsilon_\sigma} = \frac{1}{|G|} \sum_{i \in G} \prod_{i=0}^3 W(\sigma_i, \varphi_i)^{\varepsilon_i} \text{ for any } \varphi \in \text{Col}(T, \tau).$$

Suppose that by a colour  $\varphi \in \text{Col}(T, \tau)$ , elements of  $G$  are assigned to oriented edges of  $\sigma$  as in Fig. 2. Since  $\varepsilon_\sigma = -\varepsilon_0 = \varepsilon_1 = -\varepsilon_2 = \varepsilon_3$ , the following equation implies (3.2).

$$\alpha(g, h, k) = \frac{1}{|G|} \sum_{i \in G} \alpha(h, k, l)^{-1} \alpha(gh, k, l) \alpha(g, hk, l)^{-1} \alpha(g, h, kl).$$

This equation follows from the 3-cocycle condition for  $\alpha$ . This completes the proof.

**Lemma 3.3.** *Let  $M$  be a compact oriented triangulated 3-manifold. Then for any  $\tau \in \text{Col}(\partial M)$ , the complex number  $Z_M(\tau)$  is invariant under the Alexander move along an open 2-simplex which is not contained in  $\partial M$ .*

Proof. Let  $T$  be a given triangulation of  $M$  and  $T'$  a triangulation of  $M$  obtained from  $T$  by the Alexander move along an open 2-simplex  $F$  of  $T$  which is not contained in  $\partial M$ . There are exactly two 3-simplices  $\sigma, \sigma'$  of  $T$  which has  $F$  as a 2-face. Let  $a$  be the number of vertices of  $T$ . Let  $v_0, v_1, v_2, v_3, v_4, v_6, \dots, v_a$  be the vertices of  $T$  and  $v_5$  the new vertex of  $T'$  added to  $T$ . We give an order to the vertices of  $T$  such that

$$v_0 < v_1 < v_2 < v_3 < v_4 < v_6 < \dots < v_a,$$

and to the vertices of  $T'$  such that

$$v_0 < v_1 < v_2 < v_3 < v_4 < v_5 < v_6 < \dots < v_a.$$

We denote new 3-simplices  $|v_0v_2v_3v_5|$ ,  $|v_0v_1v_3v_5|$ ,  $|v_0v_1v_2v_5|$ ,  $|v_1v_2v_4v_5|$ ,  $|v_1v_3v_4v_5|$  and  $|v_2v_3v_4v_5|$  of  $T'$  by  $\sigma_1, \sigma_2, \sigma_3, \sigma_4, \sigma_5$ , and  $\sigma_6$ , respectively.

For any  $\varphi \in \text{Col}(T, \tau)$  and any  $m \in G$ , there is a unique colour  $\varphi_m$  of  $T'$  such that it is equal to  $\varphi$  on  $M - \text{Int}\sigma \cup \text{Int}\sigma'$  and  $\varphi_m(\langle v_3, v_5 \rangle) = m$ . Therefore it is sufficient to prove that

$$(3.3) \quad W(\sigma, \varphi)^{\varepsilon_\sigma} W(\sigma', \varphi)^{\varepsilon_{\sigma'}} = \frac{1}{|G|} \sum_{m \in G} \prod_{i=1}^6 W(\sigma_i, \varphi_m)^{\varepsilon_i} \text{ for any } \varphi \in \text{Col}(T, \tau).$$

Suppose that by a colour  $\varphi \in \text{Col}(T, \tau)$ , elements of  $G$  are assigned to



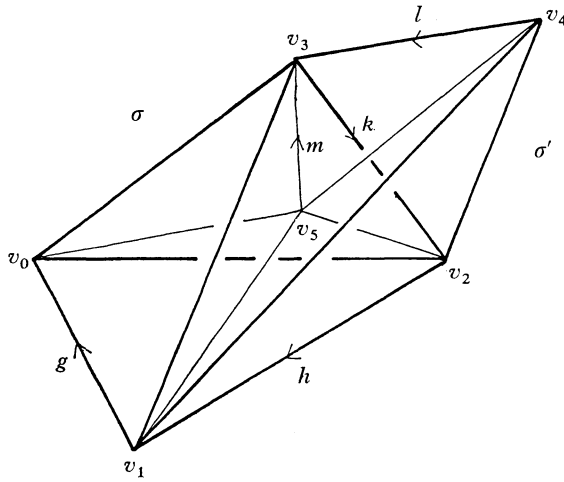

Fig. 3

oriented edges of  $\sigma$  and  $\sigma'$  as in Fig. 3. Since  $\varepsilon_\sigma = \varepsilon_{\sigma'} = -\varepsilon_1 = \varepsilon_3 = \varepsilon_5 = -\varepsilon_4 = \varepsilon_6 = -\varepsilon_6$ , the following equation implies (3.3).

$$\alpha(g, h, k)\alpha(h, k, l) = \frac{1}{|G|} \sum_{m \in \mathcal{G}} \frac{\alpha(g, h, km)\alpha(gh, k, m)\alpha(hl, l, l^{-1}m)}{\alpha(g, hk, m)\alpha(h, kl, l^{-1}m)\alpha(k, l, l^{-1}m)}.$$

By the 3-cocycle condition for  $\alpha$ , we have

$$\begin{aligned} \frac{\alpha(g, h, km)\alpha(gh, k, m)}{\alpha(g, hk, m)} \cdot \frac{\alpha(hk, l, l^{-1}m)}{\alpha(h, kl, l^{-1}m)\alpha(k, l, l^{-1}m)} \\ = \alpha(h, k, m)\alpha(g, h, k) \frac{\alpha(h, k, l)}{\alpha(h, k, ll^{-1}m)} \\ = \alpha(g, h, k)\alpha(h, k, l). \end{aligned}$$

Therefore the equation (3.3) holds. This completes the proof.

**Lemma 3.4.** *Let  $M$  be a compact oriented triangulated 3-manifold. Then for any  $\tau \in \text{Col}(\partial M)$ , the complex number  $Z_M(\tau)$  is invariant under the Alexander move along an open 1-simplex which is not contained in  $\partial M$ .*

*Proof.* Let  $T$  be a given triangulation of  $M$ , and  $T'$  a triangulation of  $M$  obtained from  $T$  by the Alexander move along an open 1-simplex  $E$  of  $T$  which is not contained in  $\partial M$ . Let  $t$  be the number of 3-simplices of  $T$  which has  $E$  as an edge. We denote these 3-simplices by  $\sigma_1, \dots, \sigma_t$ . Here we suppose that  $\sigma_i$  is adjacent to  $\sigma_{i-1}$  for each  $i$  ( $1 \leq i \leq t+1$ ), where  $\sigma_0 = \sigma_t$  and  $\sigma_{t+1} = \sigma_1$ . Let  $a$  be the number of vertices of  $T$ . Let  $v_0, v_1, \dots, v_t, v_{t+2}, \dots, v_a$  be the vertices of  $T$  and  $v_{t+1}$  the new vertex of  $T'$  added to  $T$ . We put  $\sigma_i = |v_{i-1}v_i v_{t+2}|$  for each  $i$  ( $1 \leq i \leq t$ ). We give an order to the vertices of  $T$  such that

$$v_0 < v_1 < \dots < v_i < v_{i+2} < \dots < v_a,$$

and to the vertices of  $T'$  such that

$$v_0 < v_1 < \dots < v_i < v_{i+1} < v_{i+2} < \dots < v_a.$$

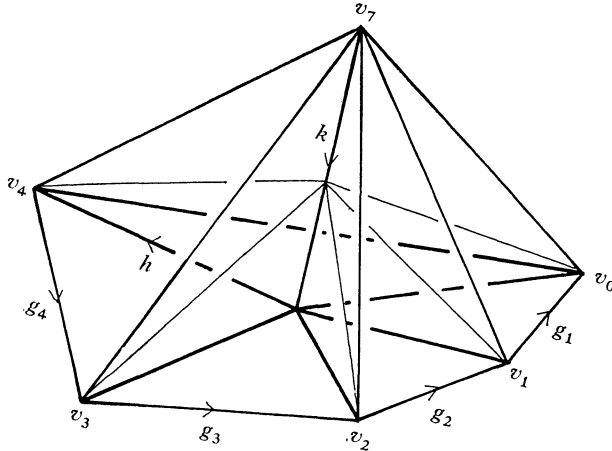

Fig. 4

For each  $i(1 \leq i \leq t)$ , we denote new 3-simplices  $|v_{i-1}v_i v_i v_{i+1}|$  and  $|v_{i-1}v_i v_{i+1} v_{i+2}|$  of  $T'$  by  $\sigma_{i0}$  and  $\sigma_{i1}$ , respectively. Let  $\sigma_1, \dots, \sigma_t, \sigma_{t+1}, \dots, \sigma_n$  be the 3-simplices of  $T$ . Then  $\sigma_{i0}, \sigma_{i1}, \dots, \sigma_{i0}, \sigma_{i1}, \sigma_{i+1}, \dots, \sigma_n$  are all the 3-simplices of  $T'$ . When we denote the set of all colours  $\varphi \in \text{Col}(T, \tau)$  such that  $\varphi(\langle v_i, v_{i+2} \rangle) = k$  by  $\text{Col}(T, \tau; k)$  for each  $k \in G$ ,  $\text{Col}(T, \tau)$  is the disjoint union  $\coprod_{k \in G} \text{Col}(T, \tau; k)$ . In a similar way, when we denote the set of all colours  $\psi \in \text{Col}(T', \tau)$  such that  $\psi(\langle v_i, v_{i+1} \rangle) = k_1, \psi(\langle v_{i+1}, v_{i+2} \rangle) = k_2$  by  $\text{Col}(T', \tau; k_1, k_2)$  for each  $k_1$  and  $k_2 \in G$ ,  $\text{Col}(T', \tau)$  is the disjoint union  $\coprod_{k_1, k_2 \in G} \text{Col}(T', \tau; k_1, k_2)$ . So the following equation implies this lemma.

$$\begin{aligned}
 (3.4) \quad & \sum_{k \in G} \sum_{\varphi \in \text{Col}(T, \tau; k)} \prod_{i=1}^t W(\sigma_i, \varphi)^{\varepsilon_i} \prod_{i=t+1}^n W(\sigma_i, \varphi)^{\varepsilon_i} \\
 &= \frac{1}{|G|} \sum_{k_1, k_2 \in G} \sum_{\psi \in \text{Col}(T', \tau; k_1, k_2)} \prod_{i=1}^t W(\sigma_{i0}, \psi)^{\varepsilon_{i0}} W(\sigma_{i1}, \psi)^{\varepsilon_{i1}} \prod_{i=t+1}^n W(\sigma_i, \psi)^{\varepsilon_i}.
 \end{aligned}$$

We take any  $k_1, k_2 \in G$  with  $k = k_1 k_2$  and fix them. Then for any  $\psi \in \text{Col}(T', \tau; k_1, k_2)$ , there is a unique colour  $\xi(\psi) \in \text{Col}(T, \tau; k)$  such that  $\xi(\psi)$  is equal to  $\psi$  on  $T - \text{Int}E$  and  $\xi(\psi)(\langle v_i, v_{i+2} \rangle) = k$ . This map  $\xi$  is a bijection from  $\text{Col}(T', \tau; k_1, k_2)$  to  $\text{Col}(T, \tau; k)$ . Given a colour  $\psi \in \text{Col}(T', \tau; k_1, k_2)$ , we put  $\phi(\langle v_i, v_{i+1} \rangle) = g_{i+1} (i=0, 1, \dots, t-2)$ ,  $\psi(\langle v_{i-1}, v_i \rangle) = h, \psi(\langle v_i, v_{i+1} \rangle) = k_1$  and  $\psi(\langle v_{i+1}, v_{i+2} \rangle) = k_2$ . Then we have  $\psi(\langle v_i, v_{i+2} \rangle) = g_{i+1} \dots g_{i-1} h k_1 k_2 (i=0, \dots, t-2)$

and  $\psi(\langle v_{t-1}, v_{t+1} \rangle) = hk_1k_2$ .

Thus we have

$$\prod_{i=1}^t W(\sigma_{i0}, \psi)W(\sigma_{i1}, \psi) = \alpha(g_{t-1}, h, k_1)\alpha(g_{t-2}, g_{t-1}h, k_1)\cdots\alpha(g_1, g_2\cdots g_{t-1}h, k_1)$$

$$\alpha(g_{t-1}, hk_1, k_2)\alpha(g_{t-2}, g_{t-1}hk_1, k_2)\cdots\alpha(g_1, g_2\cdots g_{t-1}hk_1, k_2)$$

and

$$\prod_{i=1}^t W(\sigma_i, \xi(\psi)) = \alpha(g_{t-1}, h, k)\alpha(g_{t-2}, g_{t-1}h, k)\cdots\alpha(g_1, g_2\cdots g_{t-1}h, k).$$

Now, using the 3-cocycle condition for  $\alpha$  repeatedly, we have

$$\prod_{i=1}^t W(\sigma_{i0}, \psi)^{\varepsilon_{i0}}W(\sigma_{i1}, \psi)^{\varepsilon_{i1}} = \prod_{i=1}^t W(\sigma_i, \xi(\psi)) \frac{\alpha(g_1g_2\cdots g_{t-1}h, k_1, k_2)}{\alpha(h, k_1, k_2)}.$$

By the colouring condition for  $\psi$  we have  $g_1g_2\cdots g_{t-1} = 1$ . Since  $\varepsilon_i = \varepsilon_{i0} = \varepsilon_{i1}$  ( $1 \leq i \leq t$ ) and  $W(\sigma_i, \psi) = W(\sigma_i, \xi(\psi))$ , ( $t+1 \leq i \leq n$ ), we obtain

$$\frac{1}{|G|} \sum_{k_1, k_2 \in \mathcal{G}} \sum_{\psi \in \text{Col}(X', \tau; k_1, k_2)} \prod_{i=1}^t W(\sigma_i, \psi)^{\varepsilon_{i0}}W(\sigma_{i1}, \psi)^{\varepsilon_{i1}} \prod_{i=t+1}^n W(\sigma_i, \psi)^{\varepsilon_i}$$

$$= \frac{1}{|G|} \sum_{k_1, k_2 \in \mathcal{G}} \sum_{\psi \in \text{Col}(X', \tau; k_1, k_2)} \prod_{i=1}^t W(\sigma_i, \xi(\psi))^{\varepsilon_i} \prod_{i=t+1}^n W(\sigma_i, \xi(\psi))^{\varepsilon_i}.$$

When we fix any  $k_1 \in G$  and make  $k_2$  run all over  $G$ ,  $k = k_1k_2$  runs all over  $G$ . Thus the value

$$\sum_{k_2 \in \mathcal{G}} \sum_{\psi \in \text{Col}(X', \tau; k_1, k_2)} \prod_{i=1}^t W(\sigma_i, \xi(\psi))^{\varepsilon_i} \prod_{i=t+1}^n W(\sigma_i, \xi(\psi))^{\varepsilon_i}$$

is independent of  $k_1 \in G$ . Furthermore, we can see that this value is equal to  $\sum_{k \in \text{Col}(T, \tau; k)} \prod_{i=1}^t W(\sigma_i, \varphi)^{\varepsilon_i} \prod_{i=t+1}^n W(\sigma_i, \varphi)^{\varepsilon_i}$ . Therefore, the above identity (3.4) holds. This completes the proof.

Proof of the main theorem. By Theorem 3.1, it is sufficient to prove that the complex number  $Z_M(\tau)$  is not changed by the Alexander moves along simplices not lying on  $\partial M$ . This has been proved in Lemmas 3.2, 3.3 and 3.4.

### 4. Discussions and Examples

**4.1. Dual approach.** Turaev and Viro [11] introduced an invariant of 3-manifolds associated with quantum  $6j$ -symbols. This invariant is combinatorially defined. They considered the dual cell subdivision of a triangulation  $T$  of a 3-manifold  $M$  in order to prove its topological invariance.

The dual cell subdivision is constructed as follows. With each strictly

increasing sequence  $A_0 \subset A_1 \subset \dots \subset A_m$  of simplices of  $T$  one associates an  $m$ -simplex  $|[A_0][A_1] \cdots [A_m]|$ , where  $[A_i]$  is the barycenter of  $A_i$  for each  $i$  ( $0 \leq i \leq m$ ). For a simplex  $A$  of  $T$  we write for  $A^*$  the union all simplices  $|[A_0][A_1] \cdots [A_m]|$  with  $A_0=A$ . The cells  $\{A^*\}_A$ , where  $A$  runs over all simplices of  $M$ , is called the dual cell subdivision of  $T$ . Then

$$X = \cup_{A: \text{edges of } X} A^*,$$

is a simple 2-polyhedron [11].

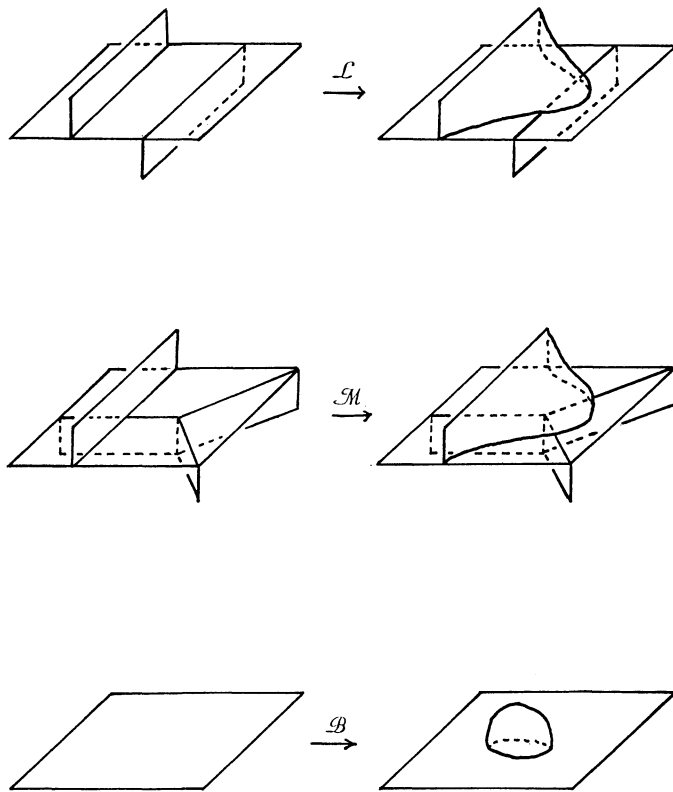

Fig. 5

Turaev and Viro introduced 3-type moves  $\mathcal{L}$ ,  $\mathcal{M}$  and  $\mathcal{B}$  on simple 2-polyhedra (See Fig. 5). Essentially these moves were considered by S. Matveev [6]. It is seen that the dual picture of Alexander moves are transformed one to another by a finite sequence of these 3-type moves. Turaev and Viro showed the following theorem using a result of S. Matveev [6] in his study of special spines of 3-manifolds.

**Theorem(Turaev-Viro).** *Let  $M$  be a compact 3-manifold with triangulat-*

ed boundary. Then any two special spines of  $M$  can be transformed one to another by a sequence of 3-type moves  $\mathcal{L}^\pm, \mathcal{M}^\pm$  and  $\mathcal{B}^\pm$ .

So Turaev and Viro translated their state sum invariant into the ‘dual’ language, and checked the invariance under 3-type moves. We can also carry out a dual approach to prove the topological invariance of the Dijkgraaf-Witten invariant since moves  $\mathcal{L}, \mathcal{M}$  and  $\mathcal{B}$  are natural with respect to orientations.

Let  $M$  be a triangulated compact oriented 3-manifold. We denote by  $X$  the simple 2-polyhedron obtained from  $M$  by the dual cell subdivision as above. For a colour  $\varphi \in \text{Col}(M, \tau)$ , we define a map

$$\varphi^*: \{\text{the oriented 2-cells of } X\} \rightarrow G$$

as follows: For any 2-cell  $F$  of  $X$  there exists a unique edge  $E$  of  $M$  such that it intersects transversely with  $F$  at only one point. For an oriented 2-cell  $F$  of  $X$ , we choose the orientation for  $E$  such that it is compatible with the orientation for  $F$ . Then we put  $\varphi^*(F) = \varphi(E)$ . We call  $\varphi^*$  a colour of  $X$ . For a colour  $\varphi^*$  of  $X$  we define a map

$$\partial\varphi^*: \{\text{the oriented edges of } \partial X\} \rightarrow G$$

as follows. For an oriented edge  $\Gamma$  of  $\partial X$  there is a unique 2-cell  $F$  of  $X$  such that  $\Gamma$  is in the closure of  $F$ . When we choose the orientation for  $F$  such that it is compatible with that for  $\Gamma$ , we put  $(\partial\varphi^*)(\Gamma) = \varphi^*(F)$ . We can easily check that  $\partial\varphi^* = \partial\psi^*$  for any  $\varphi, \psi \in \text{Col}(M, \tau)$ . So we denote  $\partial\varphi^*$  by  $\tau^*$  for a colour  $\varphi \in \text{Col}(M, \tau)$ . We call  $\tau^*$  a colour of  $\partial X$ . For a colour  $\tau^*$  of  $\partial X$  by  $\text{Col}(X, \tau^*)$  we denote the set of all colours  $\varphi^*$  of  $X$  such that  $\partial\varphi^*$  equals to  $\tau^*$ . Since the 3-simplices  $\sigma$  of  $M$  are in one-to-one correspondence with vertices  $a$  of  $X - \partial X$ , we can use the notation  $W(a, \varphi^*)$  for  $W(\sigma, \varphi)$ . Let  $a_1, \dots, a_n$  be the vertices of  $X - \partial X$ . Then we define a complex number  $Z_X(\tau^*)$  by the following formula:

$$Z_X(\tau^*) = w^{-2\chi(X) + \chi(\partial X)} \sum_{\varphi^* \in \text{Col}(X, \tau^*)} \prod_{i=1}^n W(a_i, \varphi^*)^{e_i},$$

where  $w = \sqrt{|G|}$ , and  $\chi(X), \chi(\partial X)$  are the Euler characteristics for  $X, \partial X$  respectively. The Dijkgraaf-Witten invariant  $Z_M(\tau)$  is related to  $Z_X(\tau^*)$  by the following identity:

$$Z_X(\tau^*) = w^e Z_M(\tau),$$

where  $e$  is the number of vertices of  $\partial M$ .

Then the invariance of  $Z_M(\tau)$  under the moves  $\mathcal{L}^\pm$  is derived from the definition of orientations for 3-simplices of  $M$  and the condition for  $\varepsilon_i$  in the main theorem. The invariance of  $Z_M(\tau)$  under the moves  $\mathcal{M}^\pm$  is derived from the 3-cocycle condition for  $\alpha$ . The invariance of  $Z_M(\tau)$  under the moves  $\mathcal{B}^\pm$  is de-

rived from the factor  $\frac{1}{|G|^s}$  in the main theorem.

**4.2. Examples.** In this subsection, we give some examples for calculations on the Dijkgraaf-Witten invariant. When  $M$  is a closed oriented 3-manifold, we denote the Dijkgraaf-Witten invariant of  $M$  by  $Z(M)$ . We use this notation to the end of this paper. We begin with the following proposition.

**Proposition 4.1.** *Let  $\alpha$  be a 3-cocycle of the cochain group  $C^3(BG, U(1))$ . Let  $M$  be a closed oriented 3-manifold. Then the invariant  $Z(M)$  depends only on the cohomology class of  $\alpha$ .*

Proof. Let  $T$  be a triangulation of  $M$ . For any  $\beta \in C^2(BG, U(1))$ , we put  $\alpha' = \alpha\delta\beta$ . Then we get

$$\begin{aligned} \alpha'([g|h|k]) &= \alpha([g|h|k])\delta\beta([g|h|k]) = \alpha([g|h|k])\beta(\partial[g|h|k]) \\ &= \alpha([g|h|k])\frac{\beta([h|k])\beta([g|h|k])}{\beta([gh|k])\beta([g|h])}. \end{aligned}$$

We give an order to the vertices of  $T$  in order to calculate  $Z(M)$ . Let  $\sigma_1, \dots, \sigma_n$  be all the 3-simplices of  $T$ . It is sufficient to prove that for any colour  $\varphi \in \text{Col}(M)$ ,

$$(4.1) \quad \prod_{i=1}^n W(\sigma_i, \varphi)^{\varepsilon_i} = \prod_{i=1}^n W'(\sigma_i, \varphi)^{\varepsilon_i},$$

where  $W(\sigma_i, \varphi)$  and  $W'(\sigma_i, \varphi)$  are complex numbers with norm 1 given by  $\alpha$  and  $\alpha'$  respectively.

For a 2-simplex  $F = |v_0v_1v_2|$  ( $v_0 < v_1 < v_2$ ) of  $T$ , we define  $W(F, \varphi)$  by  $\beta([\varphi(\langle v_0, v_1 \rangle) | \varphi(\langle v_1, v_2 \rangle)])$ .

Once given each 2-simplex  $F$  of  $T$ , there are exactly two 3-simplices  $\sigma, \sigma'$  of  $T$  which have  $F$  as a 2-face, because  $M$  is a closed 3-manifold. We give an orientation for  $F$  in the ascending order with respect to the vertices. If the orientations for  $\sigma$  and  $\sigma'$  are compatible with that for  $M$ , the orientations for  $F$  induced from them for  $\sigma$  and  $\sigma'$  are not compatible. If the orientation for  $\sigma$  is compatible with that for  $M$  but the orientation for  $\sigma'$  is not, then the orientations for  $F$  induced from them for  $\sigma$  and  $\sigma'$  are compatible.

Now for  $\sigma_i = |v_0v_1v_2v_3|$  ( $v_0 < v_1 < v_2 < v_3$ ), we put  $F_{i0} = |v_1v_2v_3|$ ,  $F_{i1} = |v_0v_2v_3|$ ,  $F_{i2} = |v_0v_1v_3|$  and  $F_{i3} = |v_0v_1v_2|$ . Then we have

$$W'(\sigma_i, \varphi) = W(\sigma, \varphi) \frac{W(F_{i0}, \varphi)W(F_{i2}, \varphi)}{W(F_{i1}, \varphi)W(F_{i3}, \varphi)}.$$

We define  $\varepsilon_{ij}$  ( $i=1, \dots, n, j=0, 1, 2, 3$ ) as follows:

$$\varepsilon_{ij} = \begin{cases} 1 & \text{if the orientation for } F_{ij} \text{ is compatible with that induced from } \sigma_i, \\ -1 & \text{otherwise.} \end{cases}$$

Then we have

$$\prod_{i=1}^n W'(\sigma_i, \varphi)^{\varepsilon_i} = \prod_{i=1}^n W(\sigma_i, \varphi)^{\varepsilon_i} \prod_{j=0}^3 W(F_{ij}, \varphi)^{\varepsilon_{ij}}.$$

Since we obtain  $\prod_{i=1}^n \prod_{j=1}^3 W(F_{ij}, \varphi)^{\varepsilon_{ij}} = 1$  from the above explanation, we have the identity (4.1). This completes the proof.

The Dijkgraaf-Witten invariant has the following properties.

**Proposition 4.2.**

- (1) *Let  $M$  be a closed oriented 3-manifold. We denote by  $-M$  the closed oriented 3-manifold with the opposite orientation. Then we have  $Z(-M) = \overline{Z(M)}$ .*
- (2) *Let  $M_1$  and  $M_2$  be closed oriented 3-manifolds. Then for the connected sum  $M_1 \# M_2$ , we have*

$$\frac{1}{|G|} Z(M_1 \# M_2) = Z(M_1) Z(M_2)$$

This proposition can be proved from the definition of the invariant by an elementary method using 3-cocycle conditions, repeatedly. But since we prove this proposition from a functorial viewpoint of the Dijkgraaf-Witten invariant, we leave our proof to the end of the subsection 4.4.

Calculations of the Dijkgraaf-Witten invariant for some closed 3-manifolds have been already described in their paper [4]. For example, we have

$$Z(S^3) = \frac{1}{|G|}, \quad Z(S^2 \times S^1) = 1$$

and

$$Z(S^1 \times S^1 \times S^1) = \frac{1}{|G|} \sum_{\substack{\varepsilon, h, k \in G \\ [\varepsilon, h] = [h, k] = [k, \varepsilon] = 1}} \frac{\alpha(g, h, k)\alpha(h, k, g)\alpha(k, g, h)}{\alpha(g, k, h)\alpha(h, g, k)\alpha(k, h, g)}$$

for any cohomology class  $[\alpha] \in H^3(BG, U(1))$ .

We calculate the Dijkgraaf-Witten invariant for the lens space  $L(p, 1)$  using a singular triangulation [11]. Regarding the lens space  $L(p, 1)$  as a quotient space of a 3-ball  $D^3$  (See [10]), we make a singular triangulation for  $L(p, 1)$  as in Fig. 6. Then there is a unique colour  $\varphi$  of this singular triangulation of  $L(p, 1)$  such that  $\varphi(\langle v_{p-1}, v_p \rangle) = g$ ,  $\varphi(\langle v_p, v_{p+1} \rangle) = h$  and  $\varphi(\langle v_{p+1}, v_{p+2} \rangle) = l$  for any  $g, h$  and  $l \in G$ . If the 3-simplex  $|v_{p-1}v_p v_{p+1}v_{p+2}|$  determines an orientation for  $L(p, 1)$ , then we have

$$\begin{aligned}
 Z(L(p, 1)) &= \frac{1}{|G|^3} \sum_{g, h, l \in G} \frac{\alpha(g, h, k)\alpha(g, gh, k)\cdots\alpha(g, g^{p-2}h, k)}{\alpha(g^{-1}, h, k)} \\
 &\quad \frac{\alpha(g^{-1}, h, l)}{\alpha(g, h, l)\alpha(g, gh, l)\cdots\alpha(g, g^{p-2}h, l)},
 \end{aligned}$$

where  $k=h^{-1}ghl$ .

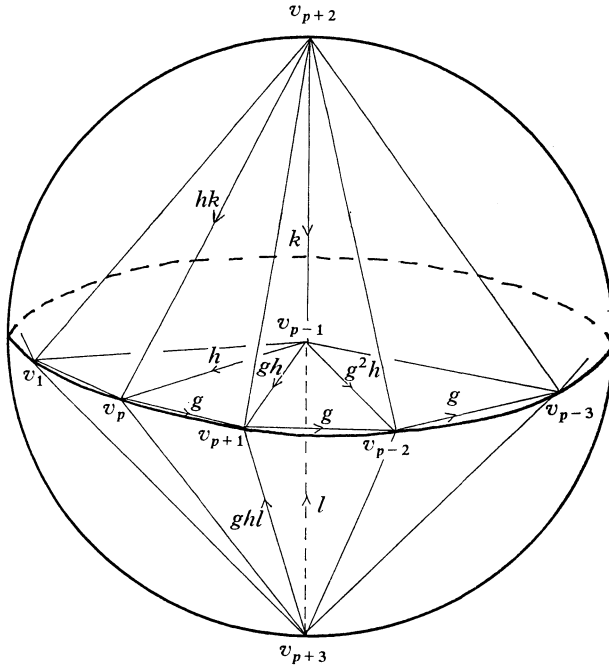

Fig. 6

Now we consider the case where  $G$  is the cyclic group  $\mathbf{Z}_m$  of order  $m$ . It is well known that  $H^3(BG, U(1)) \cong \mathbf{Z}_m$ . The cohomology group  $H^3(BG, U(1)) \cong H^3(G, U(1))$  is generated by the cohomology class of  $\alpha$  defined as follows (See [8]):

$$\alpha: G \times G \times G \rightarrow U(1), \alpha(g_1, g_2, g_3) = \exp\left(\frac{2\pi\sqrt{-1}}{m^2} \bar{g}_1(\bar{g}_2 + \bar{g}_3 - \overline{g_2 + g_3})\right)$$

where  $\bar{g}_i \in \{0, 1, \dots, m-1\}$  is a representative element for each  $i$  ( $i=1, 2, 3$ ).

In particular, in the case where  $G=\mathbf{Z}_2$ , we have

$$Z(L(p, 1)) = \begin{cases} \frac{1}{2} \{1 + (-1)^n\} & \text{if } p=2n, \\ \frac{1}{2} & \text{if } p=2n+1. \end{cases}$$



with respect to the above  $\alpha$ .

In the case where  $G = \mathbf{Z}_m$  and  $p-1=m$ , we have

$$Z(L(p, 1)) = \frac{1}{m^3} \sum_{k=1}^{m-1} \exp\left(\frac{2\pi\sqrt{-1}}{m}k\{(m-k)^2+k^2+2k(m-k)\} \cos\left(\frac{2\pi\sqrt{-1}}{m}k\right)\right) + \frac{1}{m}$$

with respect to the above  $\alpha$ .

REMARK. Recently H. Marakami, Ohtsuki and Okada[9] introduced an invariant of 3-manifolds derived from linking matrices of framed links. Let  $M$  be a closed oriented 3-manifold obtained from the standard 3-sphere  $S^3$  by Dehn surgery along a framed link  $L$  with  $n$ -components. Let  $q$  be a primitive  $m$ -th ( $2m$ -th, resp.) root of unity for an odd (even, resp.) positive integer  $m$ . Then their invariant is given by the following formula:

$$Z_m(M; q) = \left(\frac{G_m(q)}{|G_m(q)|}\right)^{\sigma(A)} |G_m(q)|^{n-n} \sum_{l \in (\mathbf{Z}_m)^n} q^{lAl},$$

where  $G_m(q) = \sum_{h \in \mathbf{Z}_m} q^{h^2}$  (a Gaussian sum),  $A$  is the linking matrix of  $L$ ,  $l$  is regarded as a column vector and  ${}^t l$  is its transposed row vector.

They examine a relation between their invariant and the Dijkgraaf-Witten invariant in the case where  $G$  is a cyclic group and  $M$  is closed. This relation is given by the following identity: For a closed oriented 3-manifold  $M$  obtained from  $S^3$  by Dehn surgery along a framed link with  $n$ -components,

$$\begin{cases} \text{if } m \text{ is odd, } Z(M) = \frac{n}{m} Z_{m^2}(M; q), \\ \text{if } m \text{ is even, } Z(M) = \frac{1}{m} Z_{m^2/2}(M; q) Z_2(M; q^{(-m^2)/4}), \end{cases}$$

where  $Z(M)$  is calculated using the above  $[\alpha] \in H^3(\mathbf{Z}_m, U(1))$  and  $q$  is an  $m^2$ -th primitive root of unity.

**4.3. The Topological Quantum Field Theory.** The construction of the Dijkgraaf-Witten invariant of a 3-manifold with boundary gives an example of a 2-dimensional topological quantum field theory[2]. We see this by means of a Turaev and Viro's method. But we need to normalize the Dijkgraaf-Witten invariant in the following way. We denote the number of vertices of  $\partial M$  by  $e$ , in the statement of the main theorem. Then we put

$$Z'_M(\tau) = w^e Z_M(\tau), \quad \text{where } w = \sqrt{|G|}.$$

The complex number  $Z'_M(\tau)$  does not depend on the choice of triangulation of  $M$  whenever we fix a triangulation of  $\partial M$  and  $\tau \in \text{Col}(\partial M)$ .

For each triangulated closed oriented surface  $\Sigma$ , we define a finite dimensional vector space  $V(\Sigma)$  to be the vector space freely generated over  $\mathbf{C}$  by the colours of  $\Sigma$ . If  $\Sigma = \phi$ , then we put  $V(\Sigma) = \mathbf{C}$ . For a cobordism  $W = (M; \Sigma_1, \Sigma_2)$

between triangulated closed oriented surfaces  $\Sigma_1$  and  $\Sigma_2$ , where the orientation for  $\Sigma_1$  is compatible to that induced from the orientation for  $M$  and the orientation for  $\Sigma_2$  is not, we have a  $\mathbf{C}$ -linear map  $\Phi_W: V(\Sigma_1) \rightarrow V(\Sigma_2)$  defined by the formula

$$\Phi_W(\tau) = \sum_{\mu \in \text{Col}(\Sigma_2)} Z'_M(\tau \cup \mu) \mu,$$

where  $\tau$  is a colour of  $\Sigma_1$  and  $\tau \cup \mu \in \text{Col}(\partial M)$  is the colour determined by  $\tau$  and  $\mu$ .

The following proposition is a consequence of the main theorem.

**Proposition 4.3.** *For any cobordism  $W=(M; \Sigma_1, \Sigma_2)$  between triangulated closed oriented surfaces  $\Sigma_1$  and  $\Sigma_2$ , the linear map  $\Phi_W: V(\Sigma_1) \rightarrow V(\Sigma_2)$  does not depend on the extension of triangulations of  $\Sigma_1$  and  $\Sigma_2$  to  $M$  involved in the definition of  $\Phi_W$ .*

By the definition of  $\Phi_W$ , composing cobordisms  $W_1=(M_1; \Sigma_1, \Sigma_2)$  and  $W_2=(M_2; \Sigma_2, \Sigma_3)$ , we have

**Proposition 4.4.**  $\Phi_{W_2 \circ W_1} = \Phi_{W_2} \circ \Phi_{W_1}$ .

REMARK. If one uses  $Z_M(\tau)$  instead of  $Z'_M(\tau)$  in the definition of  $\Phi_W$ , we get  $\Phi_{W_2 \circ W_1} = |G|^b \Phi_{W_2} \circ \Phi_{W_1}$ , where  $b$  is the number of vertices of  $\Sigma_2$ .

For any triangulated closed oriented surface  $\Sigma$ , we denote by  $id_\Sigma$  the identity cobordism. Then we put

$$H_\Sigma = V(\Sigma) / \text{Ker } \Phi_{id_\Sigma}.$$

From Proposition 4.4, we obtain the following lemma.

**Lemma 4.1.** *For any cobordism  $W$  between triangulated oriented closed surfaces  $\Sigma_1$  and  $\Sigma_2$ , the map  $\Phi_W: V(\Sigma_1) \rightarrow V(\Sigma_2)$  induces a  $\mathbf{C}$ -linear map  $Z_W: H_{\Sigma_1} \rightarrow H_{\Sigma_2}$  with the following properties:*

- (1) *Let  $W_1=(M_1; \Sigma_1, \Sigma_2)$  and  $W_2=(M_2; \Sigma_2, \Sigma_3)$  be cobordisms between triangulated oriented closed surfaces. Then we obtain that  $Z_{W_2 \circ W_1} = Z_{W_2} \circ Z_{W_1}$ .*
- (2) *For any triangulated oriented closed surface  $\Sigma$ , we obtain that  $Z_{id_\Sigma} = id_{H_\Sigma}$ .*

The vector space  $H_\Sigma$  does not depend on the choice of triangulation of an oriented closed surface  $\Sigma$  in the following sense. We explain this in the same manner as Turaev and Viro [11]. For any triangulation of  $\Sigma$ , there exists a triangulation of  $\Sigma \times [0, 1]$  coinciding on  $\Sigma \times 0$  and  $\Sigma \times 1$  with these given triangulations. It determines an isomorphism between the  $H_\Sigma$ 's which are defined via these triangulations of  $\Sigma$  by Lemma 4.1. By Proposition 4.4, this isomorphism

does not depend on the choice of triangulation of  $\Sigma \times [0, 1]$ . We will identify the spaces  $H_\Sigma$  defined via different triangulations of  $\Sigma$  by this isomorphism.

In this manner, we obtain a functor  $Z$  from the category such that objects are closed oriented surfaces and morphisms are cobordisms between them to the category such that objects are finite dimensional vector spaces over  $\mathbb{C}$  and morphisms are  $\mathbb{C}$ -linear maps. This functor  $Z$  does not depend on the choice of triangulation in the sense that there exists a canonical natural transformation.

**Proposition 4.5.** *The functor  $Z$  satisfies the axiom for the 2-dimensional topological quantum field theory.*

*Proof.* It is easy to check the Multiplicativity axiom for  $Z$  by the definition of  $V(\Sigma)$ . Thus from Lemma 4.1, we have only to check the Involutory axiom for  $Z$ .

Let  $\Sigma^*$  be the triangulated closed oriented surface with the opposite orientation for  $\Sigma$ . Then clearly,  $V(\Sigma) = V(\Sigma^*)$ , by the definition of  $V(\Sigma)$ . We define a map  $\varphi: V(\Sigma^*) \rightarrow V(\Sigma)^*$  by

$$(\varphi(v))(v') = \sum_{\mu \in \text{Col}(\Sigma)} \sum_{\nu \in \text{Col}(\Sigma)} a_\mu b_\nu Z'_{\Sigma \times [0,1]}(\mu \cup \nu)$$

for  $v = \sum_{\mu \in \text{Col}(\Sigma)} a_\mu \mu \in V(\Sigma)$  and  $v' = \sum_{\nu \in \text{Col}(\Sigma)} b_\nu \nu \in V(\Sigma)$  where  $a_\mu$  is the complex conjugation of  $a_\mu$ . From the fact that  $\Phi_{id_\Sigma}(\vartheta) = 0$  if and only if  $\Phi_{id_{\Sigma^*}}(v) = 0$ , where  $\vartheta = \sum a_\mu \mu$  for  $v = \sum a_\mu \mu$ , it follows that the map  $\varphi$  induces a  $\mathbb{C}$ -linear map  $\bar{\varphi}: H_{\Sigma^*} \rightarrow H_\Sigma^*$ , where  $H_\Sigma^*$  is the dual space of  $H_\Sigma$ .

To show that  $\bar{\varphi}$  is an isomorphism, we construct the inverse map for  $\bar{\varphi}$ . Since  $\Phi_{id_\Sigma} \circ \Phi_{id_\Sigma} = \Phi_{id_\Sigma}$ , we have a direct sum decomposition:  $V(\Sigma) = \text{Im } \Phi_\Sigma \oplus \text{Ker } \Phi_\Sigma$ . Under this decomposition, the natural projection  $p: V(\Sigma) \rightarrow H_\Sigma$  is the first projection  $\text{Im } \Phi_{id_\Sigma} \oplus \text{Ker } \Phi_{id_\Sigma} \rightarrow \text{Im } \Phi_{id_\Sigma} \cong H_\Sigma$ . Since  $\text{Im } \Phi_{id_\Sigma}$  is generated by  $\{\Phi_{id_\Sigma}(\tau) \mid \tau \in \text{Col}(\Sigma)\}$ ,  $(\text{Im } \Phi_{id_\Sigma})^* \cong H_\Sigma^*$  is generated by  $\{\tau^* \mid \tau \in \text{Col}(\Sigma)\}$ , where  $\tau^*(\mu) = Z'_{\Sigma \times [0,1]}(\tau \cup \mu)$  for any  $\mu \in \text{Col}(\Sigma)$ .

Putting

$$\bar{\psi} \left( \sum_{\tau \in \text{Col}(\Sigma)} a_\tau \tau^* \right) = \left[ \sum_{\tau \in \text{Col}(\Sigma)} a_\tau \tau \right],$$

this correspondence induces a well-defined map  $\bar{\psi}: H_\Sigma^* \cong (\text{Im } \Phi_{id_\Sigma})^* \rightarrow H_{\Sigma^*}$ . Then  $\bar{\varphi}$  and  $\bar{\psi}$  satisfy that  $\bar{\varphi} \circ \bar{\psi} = id$  and  $\bar{\psi} \circ \bar{\varphi} = id$ . Therefore, we obtain a canonical isomorphism between  $H_{\Sigma^*}$  and  $H_\Sigma^*$ . This completes the proof.

**4.4. Representations of Mapping Class Groups.** In this section, we consider the group  $\Gamma := \text{Homeo}^+(\Sigma) / \sim$  consisting of isotopy classes of orientation preserving homeomorphisms on an oriented closed surface  $\Sigma$ . By means of Turaev-Viro's method, we can construct a representation of  $\Gamma$  associated with the Dijkgraaf-Witten invariant.

Let  $\Sigma$  be a closed oriented surface and  $h: \Sigma \rightarrow \Sigma$  an orientation preserving homeomorphism. We fix a triangulation of  $\Sigma$ . Then we define a  $\mathbb{C}$ -linear map  $h_{\sharp}: V(\Sigma) \rightarrow V(\Sigma)$  by

$$h_{\sharp}(\tau) = \sum_{\mu \in \text{Col}(\Sigma)} Z'_{\Sigma \times [0,1]}(h(\tau) \cup \mu)\mu$$

for any  $\tau \in \text{Col}(\Sigma)$ . Here  $h(\tau)$  is a colour of  $\Sigma$  defined as follows: A triangulation of  $\Sigma_0 = \Sigma \times 0$  is induced from the given triangulation of  $\Sigma$  and the homeomorphism  $h$ . Then for each oriented edges  $E$  of  $\Sigma_0$ , we define  $h(\tau)(E)$  by  $h(\tau)(E) = \tau(h^{-1}(E))$ .

Now we have the following lemma from the main theorem and the definition of  $h_{\sharp}$ .

**Lemma 4.2.** *Let  $\Sigma$  be a triangulated closed surface. If  $h$  and  $g$  are piecewise linear orientation preserving homeomorphisms on  $\Sigma$ , then  $(h \circ g)_{\sharp} = h_{\sharp} \circ g_{\sharp}$ .*

Let  $\Sigma$  be a closed oriented surface and  $h$  an orientation preserving homeomorphism on  $\Sigma$ . For a triangulation  $T$  of  $\Sigma$ , we denote by  $T'$  the triangulation of  $\Sigma$  induced from  $T$  and  $h$ . We define a  $\mathbb{C}$ -linear isomorphism  $h^{\sharp}: V(\Sigma; T) \rightarrow V(\Sigma; T')$  by  $h^{\sharp}(\tau) = h(\tau)$  for any colour  $\tau \in \text{Col}(\Sigma; T)$ , where  $\text{Col}(\Sigma; T)$  and  $V(\Sigma; T)$  stand for the set of colours and the vector space determined by the triangulation  $T$  as in above, respectively. Considering the cobordism  $W = (\Sigma \times [0, 1]; \Sigma \times 0, \Sigma \times 1)$  such that triangulations of  $\Sigma \times 0$  and  $\Sigma \times 1$  are  $T'$  and  $T$  respectively, we have

$$h_{\sharp} = \Phi_W \circ h^{\sharp}.$$

Since  $Z'_{\Sigma \times [0,1]}(\tau \cup \mu) = Z'_{\Sigma \times [0,1]}(h(\tau) \cup h(\mu))$  for any  $\mu, \tau \in \text{Col}(\Sigma; T)$ , the  $\mathbb{C}$ -linear isomorphism  $h^{\sharp}$  induces a  $\mathbb{C}$ -linear map  $H_{\Sigma} \rightarrow H_{\Sigma}$ . Thus  $h_{\sharp}$  induces a  $\mathbb{C}$ -linear map  $h_*: H_{\Sigma} \rightarrow H_{\Sigma}$ . The map  $h_*$  does not depend on the choice of triangulation of  $\Sigma$  in the previous sense. The identity  $(h \circ g)_{\sharp} = h_{\sharp} \circ g_{\sharp}$  implies  $(h \circ g)_* = h_* \circ g_*$ . Furthermore,  $id_* = id_{H_{\Sigma}}$ . Therefore  $h_*$  is an isomorphism for any orientation preserving homeomorphism  $h$ .

**Lemma 4.3.** *If orientation preserving homeomorphisms  $h$  and  $g$  on an oriented closed surface  $\Sigma$  are isotopic, then  $h_{\sharp} = g_{\sharp}$ , and therefore  $h_* = g_*$ .*

Proof. Let  $H: \Sigma \times [0, 1] \rightarrow \Sigma$  be an isotopy between  $h$  and  $g$ . Then there exists a homeotopy  $\hat{H}: \Sigma \times [0, 1] \rightarrow \Sigma \times [0, 1]$  such that  $\hat{H}_0 = id_{\Sigma}$  and  $\hat{H}_t \circ h = H_t$ , where  $\hat{H}(x, t) = (\hat{H}_t(x), t)$ . In particular,  $\hat{H}_1 \circ h = g$ . Since  $\hat{H}_1$  is an orientation preserving homeomorphism, we have  $Z'_{\Sigma \times [0,1]}(h(\tau) \cup \mu) = Z'_{\Sigma \times [0,1]}(g(\tau) \cup \mu)$ . This completes the proof.

The above construction of the linear map  $h_*: H_{\Sigma} \rightarrow H_{\Sigma}$  enables us to obtain a linear representation of  $\Gamma$ . More precisely we have the following proposition.

**Proposition 4.6.** *Let  $\Sigma$  be a closed oriented surface. We put  $\Gamma := \text{Homeo}^+(\Sigma)/\sim$ . We define a map  $\rho: \Gamma \rightarrow GL(H_\Sigma)$  by  $\rho(h) = h_*$ , then  $\rho$  is a representation of  $\Gamma$ .*

**Proposition 4.7.** *Let  $\Sigma$  be a closed oriented surface and  $f: \Sigma \rightarrow \Sigma$  an orientation preserving homeomorphism. We define the mapping torus  $\Sigma_f$  by identifying a point  $(x, 0)$  with a point  $(f(x), 1)$  of  $\Sigma \times [0, 1]$ . Then we have*

$$Z(\Sigma_f) = \text{Trace}(f_*) .$$

Proof. We fix a triangulation  $T$  of  $\Sigma$ . By  $T'$  we denote the triangulation of  $\Sigma$  induced from  $T$  and  $f$ . We put  $W_1 = (M_1 = \Sigma \times [0, 1]; \phi, \Sigma \times \{0, 1\})$ , where triangulations of  $\Sigma \times 0$  and  $\Sigma \times 1$  are  $T$  and  $W_2 = (M_2 = \Sigma \times [0, 1]; \Sigma \times \{0, 1\}, \phi)$ , where triangulations for  $\Sigma \times 0$  and  $\Sigma \times 1$  are  $T'$  and  $T$  respectively. Then we can regard  $\Sigma_f$  as  $M_1 \cup M_2$ , and the linear map  $Z_{W_1}: \mathcal{C} \rightarrow H_\Sigma^* \otimes H_\Sigma$  and  $Z_{W_2}: H_\Sigma^* \otimes H_\Sigma \rightarrow \mathcal{C}$  as vectors in  $H_\Sigma^* \otimes H_\Sigma$  and  $(H_\Sigma^* \otimes H_\Sigma)^* \cong H_\Sigma \otimes H_\Sigma^*$  in a usual way respectively. Since the functor  $Z$  satisfies the axiom for the topological quantum field theory, we have

$$Z(\Sigma_f) = \langle Z_{W_1}, Z_{W_2} \rangle ,$$

where  $\langle , \rangle$  is the natural pairing.

Let  $e_1, \dots, e_n$  be a basis for  $H_\Sigma$  and  $e_1^*, \dots, e_n^*$  the dual basis for  $H_\Sigma^*$ . Then we obtain  $Z_{W_1} = \sum_{i=1}^n e_i^* \otimes e_i \in H_\Sigma^* \otimes H_\Sigma$  and  $Z_{W_2} = \sum_{i,j=1}^n f_{ij} e_i \otimes e_j^* \in H_\Sigma \otimes H_\Sigma^*$ , where  $f_*(e_i) = \sum_{j=1}^n f_{ji} e_j$ . Therefore we have

$$Z(\Sigma_f) = \langle \sum_{i=1}^n e_i^* \otimes e_i, \sum_{i,j=1}^n f_{ij} e_i \otimes e_j^* \rangle = \sum_{i=1}^n f_{ii} = \text{Trace}(f_*) .$$

This completes the proof.

In particular, for a closed oriented surface  $\Sigma$ , taking the identity map on  $\Sigma$  as  $f$  in the statement of the above proposition, we get the following corollary.

**Corollary.** *Let  $\Sigma$  be a closed oriented surface. Then we have  $Z(\Sigma \times S^1) = \dim H_\Sigma$ .*

REMARK. In the case of the Dijkgraaf-Witten invariant, since  $H_\Sigma \cong \text{Im } \Phi_{id_\Sigma}$  and  $\Phi_{id_\Sigma} \circ \Phi_{id_\Sigma} = \Phi_{id_\Sigma}$  for a triangulated closed oriented surface  $\Sigma$ , we have  $\dim H_\Sigma = \text{rank } \Phi_{id_\Sigma} = \text{Trace}(\Phi_{id_\Sigma})$ .

Finally, we give a proof of the proposition 4.2.

Proof of the proposition 4.2. The first part of the proposition is immediately proved from the definition of the invariant. We show the second part of the proposition. Since  $\dim H_{S^2} = 1$  from the above corollary, the vector space  $H_{S^2}$  is generated by a vector  $e$  in  $H_{S^2}$ . We denote the dual basis of for  $e$  by  $e^*$ .

We regard  $M_1$  and  $M_2$  as  $(M_1 - \text{Int} D_1^3) \cup D_1^3$  and  $(M_2 - \text{Int} D_2^3) \cup D_2^3$ , respectively, where  $D_1^3$  and  $D_2^3$  are 3-balls. We put  $W_1 = (M_1 - \text{Int} D_1^3; \phi, \partial D_1^3 \cong S^2)$ ,  $W_2 = (M_2 - \text{Int} D_2^3; \partial D_2^3 \cong S^2, \phi)$ ,  $W_3 = (D_1^3; \partial D_1^3 \cong S^2, \phi)$  and  $W_4 = (D_2^3; \phi, \partial D_2^3 \cong S^2)$ .

Regarding the linear maps  $Z_{W_1}$ ,  $Z_{W_2}$ ,  $Z_{W_3}$  and  $Z_{W_4}$  as vectors in  $H_{S^2}$ ,  $H_{S^2}^*$ ,  $H_{S^2}^*$  and  $H_{S^2}$  we write for  $Z_{W_1} = a_1 e$ ,  $Z_{W_2} = a_2 e^*$ ,  $Z_{W_3} = b_1 e^*$  and  $Z_{W_4} = b_2 e$ , respectively. We get  $S^3$  by identifying the boundaries of  $D_1^3$  and  $D_2^3$  in a natural way:  $S^3 = D_1^3 \cup D_2^3$ . Then we have

$$\begin{aligned} Z(M_1) &= \langle Z_{W_2}, Z_{W_4} \rangle = \langle a_1 e, b_1 e^* \rangle = a_1 b_1, \\ Z(M_2) &= \langle Z_{W_4}, Z_{W_2} \rangle = \langle b_2 e, a_2 e^* \rangle = a_2 b_2, \\ Z(S^3) &= \langle Z_{W_4}, Z_{W_3} \rangle = \langle b_2 e, b_1 e^* \rangle = b_1 b_2. \end{aligned}$$

When we regard  $M_1 \# M_2$  as  $(M_1 - \text{Int} D_1^3) \cup (M_2 - \text{Int} D_2^3)$ , we have  $Z(M_1 \# M_2) = \langle a_1 e, a_2 e^* \rangle = a_1 a_2$ . Since  $Z(S^3) = \frac{1}{|G|}$ , we obtain

$$\frac{1}{|G|} Z(M_1 \# M_2) = Z(M_1) Z(M_2).$$

This completes the proof.

### References

- [1] J.W. Alexander: *The combinatorial theory of complexes*, Ann. of Math. (2) **31** (1930), 294–322.
- [2] M. Atiyah: *Topological quantum field theories*, Publ. Math. IHES **68** (1989), 175–186.
- [3] K.S. Brown: *Cohomology of groups*, Graduate Texts in Mathematics vol. 78, Berlin, Heidelberg, New York, Springer (1982).
- [4] R. Dijkgraaf and E. Witten: *Topological gauge theories and group cohomology*, Comm. Math. Phys. **129** (1990), 393–429.
- [5] S. Eilenberg and J.A. Zilber: *Semi-simplicial complexes and singular homology*, Ann. of Math. **51** (1950), 499–513.
- [6] S.V. Matveev: *Transformations of special spines and the Zeeman conjecture*, Math. USSR Izvestia **31** no.2 (1988), 423–434.
- [7] J.P. May: *Simplicial objects in algebraic topology*, Van Nostrand Math. Studies no.11 Princeton New Jersey, Tronto, London, Melbourne, Van Nostrand (1967).
- [8] G. Moore and N. Seiberg: *Classical and quantum conformal field theory*, Comm. Math Phys. **123** (1989), 177–254.
- [9] H. Murakami, T. Ohtsuki and M. Okada: *Invariants of three-manifolds derived fom linking matrices of framed links*, Osaka J. Math. **29** (1992).
- [10] D. Rolfsen: *Knots and links*, Publish or Perish (1976).
- [11] V.G. Turaev and O.Y. Viro: *State sum invariants of 3-manifolds and quantum 6j-symbols*, LOMI preprint.

- [12] D. Yetter: Topological quantum field theories associated to finite groups and crossed  $G$ -sets, *Journal of Knot Theory and Its Ramifications*, **1** (1992), 1–20.

Note-added in proof: After we finished writing the final version of this paper, we knew that Yetter [12] have studied in the case where a 3-cocycle  $\alpha$  is trivial.

Department of Mathematics  
Kyushu University 33  
Fukuoka 812  
Japan

Present address  
Department of Mathematical Sciences  
University of Tokyo  
Hongo, Tokyo 113  
Japan