

Title	The Syntax of Passive Constructions
Author(s)	Honda, Takahiro
Citation	大阪大学, 2013, 博士論文
Version Type	VoR
URL	https://hdl.handle.net/11094/25158
rights	
Note	

Osaka University Knowledge Archive : OUKA

<https://ir.library.osaka-u.ac.jp/>

Osaka University

The Syntax of Passive Constructions

A Thesis

Submitted in Partial Fulfillment of the Requirements

for the Award of the Degree of

Doctor of Philosophy

from

Osaka University

by

Takahiro Honda, B.A., M.A.

December 2012

To my parents, Takaaki and Ake Honda

Acknowledgements

This doctoral dissertation is an extensively revised version of my preliminary doctoral thesis submitted to Osaka University in November 2011. I would like to express my deepest gratitude to Professor Yukio Oba, who introduced me to linguistics, and Professor Sadayuki Okada, for helping me with all the chapters and giving me the chance to write this thesis. I am also grateful to Professor Koji Fujita at Kyoto University, who generously answered my silly questions via e-mail. My hearty thanks also go to Assistant Professor Mayumi Yoshimoto, who gave me some helpful advice and assisted me with my research.

In addition to the abovementioned four, I would like to thank the following people for their critical comments and encouragement: Koji Shimamura, Yusuke Minami, Eri Tanaka, Hiroki Shinohara, Hideharu Tanaka, Yusuke Imanishi, Kazuhisa Murata, Maiko Yamaguchi, Yusuke Hiramatsu, and graduate students I spent time with at Osaka University.

Table of Contents

1. Introduction	1
1.1. Background	1
1.2. Organization	4
2. Accusative Case and the Transitive Light verb in Passive Constructions	6
2.1. Introduction.....	6
2.2. Some Differences between Passives and Unaccusatives	9
2.2.1. Implication of an External Argument	9
2.2.2. Accusative Case Assignment	13
2.2.2.1. The Passive of the DOC	13
2.2.2.2. The Passive of the Possessor-Raising Construction	19
2.2.2.3. The Ukrainian Passive.....	21
2.3. Proposal	22
2.3.1. The Structure of Passives	22
2.3.2. Two Chains	28
2.4. Some Consequences	32
2.4.1. Presence of an Implicit Argument	32
2.4.2. Absence of Passive Unaccusative.....	33
2.4.3. v^* and Accusative Case Assignment.....	35
2.4.3.1. The Passive of the DOC	35
2.4.3.1.1. The Structure of the Passive DOC	38
2.4.3.1.2. The Case of DO: Inherent vs. Structural	40
2.4.3.2. The Passive of the Possessor-Raising Construction	42

2.4.3.3. The Ukrainian Passive	45
2.5. SPEC- <i>v</i> * and Expletives	48
2.6. Further Issues	52
2.6.1. Three Types of Light Verb	53
2.6.2. The Difference between English Passives and Japanese Passives	54
2.6.3. The <i>have</i> Passive	57
2.7. Conclusion	60
Appendix to Chapter 2: A Recent Approach to the Passive	61
3. On the Passivizability of Idioms in English and Japanese	65
3.1. Introduction.....	65
3.2. Passivizable and Unpassivizable Idioms	69
3.2.1. Type I Idioms	71
3.2.2. Type II Idioms.....	74
3.3. Some Cases Where Type II Idioms Can Passivize	76
3.4. The Focus-Agreement Parameter and the EPP on T.....	80
3.4.1. A-Movement in Japanese.....	81
3.4.2. Topic and Focus	83
3.4.3. +focus in Japanese.....	85
3.5. Proposal	88
3.6. Some Exceptions.....	98
3.6.1. Possessor-Raising Constructions.....	98
3.6.2. Unaccusative Idioms	101
3.7. Conclusion	104

4. On Pseudopassives and the Case Assignment of P	106
4.1. Introduction.....	106
4.2. Pseudopassives and Peculiar Passives.....	111
4.2.1. Takami (1992).....	111
4.2.2. Kageyama and Ura (2002)	113
4.3. Against Reanalysis.....	116
4.3.1. Baltin and Postal (1996).....	116
4.3.2. Inada (1981).....	118
4.4. Proposal	120
4.4.1. The Case Assignment of Prepositions.....	121
4.4.2. Deriving the Passive	122
4.4.3. Non-Existent Pseudopassives.....	125
4.4.4. Languages That Do Not Allow Pseudopassives	128
4.5. Some Consequences	129
4.6. On P-Stranding under \bar{A} -Movement.....	149
4.7. Languages That Disallow P-stranding.....	151
4.8. Conclusion	156
5. On the Passivizability of Perception and Causative Verbs.....	158
5.1. Introduction.....	158
5.2. Previous Analyses.....	160
5.2.1.1. Review of Hornstein et al. (2008)	160
5.2.1.2. Examination of Hornstein et al. (2008).....	167
5.2.2.1. Review of Felser (1998)	168

5.2.2.2. Examination of Felser (1998).....	174
5.2.3.1. Review of Basilico (2003)	177
5.2.3.2. Examination of Basilico (2003).....	187
5.3. Proposal	189
5.4. What Looks like the Passive Counterpart.....	191
5.5. Conclusion	198
6. Concluding Remarks.....	199
References	202

CHAPTER ONE

INTRODUCTION

This thesis presents an analysis of passive constructions in the Minimalist Program. Through a study of the Double Object Construction, the Possessor-Raising Construction, the passivization of idioms, the pseudopassive, and perception and causative verbs, I clarify how passive sentences are derived. Passivization is one of the most famous syntactic phenomena, but we have yet to find a satisfactory account of its syntactic structure: indeed, it has proven very difficult to present a uniform theory to account for the wide variety of passive constructions. In this study, I adopt the Minimalist Program framework, especially the phase-based framework (see Chomsky (2000, 2001, 2004, 2008)), and I propose a syntactic structure of passives that can explain various phenomena in passive constructions.

1.1. Background

In an active transitive sentence, the external argument is the subject, and the internal argument appears as the object, as in (1).

(1) John kissed Mary.

On the other hand, in a passive sentence, the internal argument becomes the subject, and the external argument appears with the preposition *by* as an adjunct phrase. In addition, the passive morpheme is attached to the verb in passives, as illustrated in (2).

(2) Mary was kissed by John.

Thus, passivization seems to be a simple phenomenon in which the internal argument becomes the subject of a sentence.

At this point, we cannot tell whether passivization is a lexical operation or a syntactic one. However, the subject of a passive sentence is not always the internal argument. The subject in (3b) is not the internal argument but is rather a *part* of the internal argument, i.e. the infinitival clause *there to be a strange man in this room*, as in the active sentence (3a).

- (3) a. John believes there to be a strange man in this room.
b. There is believed to be a strange man in this room (by John).

This can be verified by the fact that *there* itself cannot be the internal argument of the verb *believe*, as illustrated below:

(4) *John believes there.

The embedded subject of the infinitival complement is thought to be raised to the object position of the matrix clause (see Lasnik (1999b)), and it then moves to the subject position. Accordingly, passivization is a syntactic operation where the element in the complement position is raised to the subject position.

Why, then, does such a movement occur? The driving force of this movement has been considered to be the Case of the complement. In the passive, the verb loses the ability to assign Case to its complement. This causes the complement to be raised to the subject position, where it is assigned nominative Case.

However, there are some passive sentences where accusative Case is assigned in Japanese, some dialects of English, Ukrainian, and Norwegian. How can we explain the driving force of the movement in these cases?

In this dissertation, I will prove that accusative Case is assigned in passives, and I will propose a structure of the passive that is almost the same as the structure of the active. The structure that I will propose can explain the acceptability of the passivized idioms as well as the derivation of passive sentences where accusative Case appears.

In addition, the subject of a passive sentence is not limited to a verb's internal argument or to the element in the verb's complement position. The following illustrates the case in point:

- (5) a. John talked to Mary.
- b. Mary was talked to (by John).

In (5a), *Mary* is the complement of the preposition *to*, not the complement of the verb *talk*. Although *Mary* is not the internal argument of the verb, it can be the subject of the passive counterpart to (5a). This kind of passive is called *pseudopassive*. In the literature, the subject of a pseudopassive sentence is the internal argument of the complex verb derived by reanalyzing the verb and the preposition. As we will see below, however, there remain some problems if we assume Reanalysis. Thus, we must account for the derivation of sentences like (5b) without resorting to Reanalysis.

Furthermore, it is well known that the subject of the embedded clause of perception and causative verbs cannot be passivized while it is

assigned accusative Case in the active, as in (6).

- (6) a. John made her run.
b. *She was made run (by John).

It is generally accepted that the passive counterpart to (6a) is actually (7b), but what seems to be the active counterpart to (7b) is ungrammatical, as shown in (7a).

- (7) a. *John made her to run.
b. She was made to run (by John).

I will also explain this long-standing problem in this thesis.

1.2. Organization

This dissertation is organized as follows. Chapter 2 proposes a syntactic structure of passives. I demonstrate some passive sentences where accusative Case is assigned, and I claim that the transitive light verb is included in the structure of passives. This proposal can adequately explain various syntactic phenomena found in passive constructions. Chapter 3 presents an analysis of the passivization of idioms in Japanese and English. By dealing with passivized idioms, we can prove that the *niyotte* passive is the Japanese counterpart to the English *be* passive. In chapter 4, I take up pseudopassives. The derivation of pseudopassives has been accounted for by assuming Reanalysis. I point out some problems with the Reanalysis approach, and I explain how pseudopassive sentences are derived, claiming that prepositions assign Case in a quite different way from other Case assigners. Chapter 5 discusses perception and causative verbs that take

bare infinitivals as complements. By scrutinizing the previous analyses of these verbs, I will argue that in fact these types of verbs do not derive passive sentences, and I will explain the reason. Chapter 6 presents the conclusion of this thesis.

CHAPTER TWO

ACCUSATIVE CASE AND THE TRANSITIVE LIGHT VERB IN PASSIVE CONSTRUCTIONS¹

2.1. Introduction

In the recent Minimalist Program framework (Chomsky (2001, 2008)), it has been proposed that the structure of passives is the same as that of unaccusatives, as in (1), and that an accusative Case value is never assigned in passives and unaccusatives.

$$(1) \quad [{}_{vP} \nu [{}_{VP} V DP]]$$

The light verb ν in (1) has the following properties: (i) it does not assign an external θ -role; (ii) it does not assign an accusative Case value; and (iii) it does not form a phase. In contrast to this light verb, the transitive light verb ν^* in the structure of an active transitive sentence, as in (2), has the opposite properties: (i) it assigns an external θ -role; (ii) it assigns an accusative Case value; and (iii) it forms a phase.

$$(2) \quad [{}_{\nu^*P} DP_1 [{}_{\nu^*} \nu^* [{}_{VP} V DP_2]]]$$

DP_1 = external argument, DP_2 = internal argument

Under Minimalism, Case assignment is realized through the syntactic

¹ This chapter is a revised and extended version of Honda (2009). I am indebted to Ken Hiraiwa, Masao Ochi, Sadayuki Okada, Peter Svenonius, Ken-ichi Takami, and two anonymous *EL* reviewers for their invaluable comments and suggestions. I would like to especially express my sincere gratitude to Koji Fujita and Yukio Oba for helping me from the outset of this study. I would also like to thank Yusuke Minami and Mayumi Yoshimoto for helpful comments. Needless to say, all remaining inadequacies are mine.

operation *Agree*. In (2), the probe v^* has the uninterpretable ϕ -features, and they agree with the interpretable ϕ -features of the goal DP_2 . As a consequence, v^* receives the value of the ϕ -features from DP_2 and assigns the accusative Case value to DP_2 . Moreover, the probe v^* *External-Merges* the external argument DP_1 and assigns the external θ -role to it. Through these operations, the probe v^* heads a phase. On the other hand, the light verb v in (1) does not have these properties, and it is not a probe.

Thus, in Chomsky's (2001, 2008) framework, the internal argument in passives and unaccusatives cannot be assigned an accusative Case value, and it is assigned a nominative Case value through the agreement with T. In addition, the light verb v in both constructions projects no external argument.

With respect to passives in Japanese, Hoshi (1994, 1999) also proposes that an external θ -role is suppressed, and that an internal argument is assigned Case by T (or Infl in his system) because abstract Case of the verb is absorbed. Accordingly, the structure of Japanese passives that he assumes roughly corresponds to (1) in that neither an external θ -role nor an accusative Case value is assigned.

Although passives and unaccusatives seem to have the same structure as long as the discussions above are all tenable, we can find some differences between them, which indicate that passive sentences are not consistent with (1). As we will see below, in passives, an external θ -role must be assigned, and an accusative Case value can also be assigned. Matsuoka (2003) suggests that an agent argument is projected

as specifier of the transitive light verb v^* (in his system, v) in Japanese passives. I basically agree with his idea, but I will modify his proposal because he does not mention the agreement of v^* in passives that is directly related to accusative Case assignment.

The aims of this chapter are to prove that the structure of passives is not the same as that of unaccusatives and to propose a structure of passives containing the transitive light verb v^* , by demonstrating the existence of an implicit external argument and the assignment of an accusative Case value in the passive.

The organization of this chapter is as follows. In section 2.2, I point out the differences between passives and unaccusatives and the problems with Chomsky (2001, 2008) and Hoshi (1994, 1999), by illustrating some examples of accusative Case assignment in passives. In section 2.3, I introduce Matsuoka's (2003) analysis and point out some problems. Then, I modify his claim and propose a structure of passives that contains the transitive light verb v^* instead of the light verb v . Section 2.4 demonstrates that the proposed structure can adequately explain why accusative Case assignment is possible in the passive of the Double Object Construction (DOC) in some dialects of English and in some other languages as well as in the passive of the Possessor-Raising Construction in Japanese and in some Ukrainian passive sentences. In section 2.5, I discuss some problems that arise from my proposal and suggest solutions for them. I argue *be* and *have* in passive constructions in section 2.6. Section 2.7 presents the conclusion of this chapter.

2.2. Some Differences between Passives and Unaccusatives

2.2.1. Implication of an External Argument

Hoshi (1991, 1994, 1999) distinguishes the *niyotte* passive from the *ni* direct passive in Japanese, as shown in (3).

- (3) a. Sensei-ga gakusei-ni hihans-are-ta.
teacher-Nom student-by criticize-Pass-Past
‘The teacher_i was affected by his student’s criticizing him_i.’ (ni direct passive)
- b. Sensei-ga gakusei-ni yotte hihans-are-ta.
teacher-Nom student-to owing criticize-Pass-Past
‘The teacher was criticized by his student.’
(*niyotte* passive)
(Hoshi (1999: 196))

According to Hoshi (1991, 1999), English also has two types of passives, the *get* passive and the *be* passive, as in (4), and the *ni* direct passive and the *niyotte* passive correspond to the *get* passive and the *be* passive, respectively.

- (4) a. John got arrested by the police. (get passive)
b. John was arrested by the police. (be passive)
(ibid.: 199)

Following his distinction, I will treat only the *niyotte* passive as the Japanese counterpart to the English *be* passive.² Henceforth, in this

² Hoshi (1991, 1994, 1999) also points out the difference between *ni* direct passives and *niyotte* passives. According to his analysis, the subject of the former is base-generated in the matrix subject position and receives an

chapter, “passives” refers to *be* passives in English and *niyotte* passives in Japanese.

As I have mentioned in section 2.1, both Chomsky (2001, 2008) and Hoshi (1994, 1999) claim that an external θ -role is never assigned in passives, just as in unaccusatives, and that, minor details aside, the structure of passives is essentially (1). However, it is observed that the behavior of passives in English is different from that of unaccusatives, as shown in (5).

- (5) a. The ship was sunk to collect the insurance. (passive)
b. *The ship sank to collect the insurance. (unaccusative)

Passives can be compatible with a rationale clause while unaccusatives cannot. According to Jaeggli (1986) and Baker et al. (1989), there is an implicit external argument in passive sentences. In (5a), the implicit argument can control into the rationale clause. On the other hand, unaccusative sentences do not contain such an argument. Hence, the grammaticality of (5a). This kind of difference can also be observed in Japanese, as in (6).³

(additional) external θ -role that is not assigned in its active counterpart as shown by the gloss in (3a), whereas that of the latter is moved from the object position. In this chapter, however, I do not discuss the difference between the constructions, and I focus only on the *niyotte* passive, which is derived by the direct movement of an internal argument to the subject position. In chapter 3, I will present some evidence that only the *niyotte* passive corresponds to the *be* passive, discussing the passive of idioms in Japanese and English.

³ In the gloss, LC (Lexical Causative) indicates a morpheme that is attached to a root to form a causative alternant. See Matsuoka (2003) for details.

- (6) a. Hokenkin-o eru tameni, (sagisi-niyotte) fune-ga
insurance-Acc get for (fraud-by) ship-Nom
sizum-er-are-ta.
sink-LC-Pass-Past
‘The ship was sunk (by a fraud) to collect the insurance.’
(passive)
- b. *Hokenkin-o eru tameni, fune-ga
insurance-Acc get for ship-Nom
sizum-ta. (sizum-ta → sizunda)
sink-Past
‘The ship sank to collect the insurance.’
(unaccusative)

This fact is not consistent with the claim that the structure of passives corresponds to (1) because the light verb *v* never assigns an external θ -role.

Furthermore, Jaeggli (1986) points out that the NP in a passive *by*-phrase is interpreted as bearing the external θ -role of the passivized predicate, as illustrated in (7).

- (7) a. Bill was killed by Mary. (Agent)
b. The package was sent by John. (Source)
c. The letter was received by Bill. (Goal)
d. That professor is feared by all students. (Experiencer)
(Jaeggli (1986: 599))

Fox and Grodzinsky (1998) claim that there is a mechanism, *θ -transmission*, that transfers the θ -role from the logical subject position

to the position of the *by*-phrase. They suggest that if it were not for an implicit external argument, the *by*-phrase would not be assigned various θ -roles as shown in (7) because the preposition *by* itself does not have the relevant θ -marking property. This supports the analysis that there must be an implicit external argument in passives in English. This phenomenon can also be found in Japanese passives, as in (8).

- (8) a. Taroo-ga Hanako-niyotte koros-are-ta.
 Taro-Nom Hanako-by kill-Pass-Past
 ‘Taro was killed by Hanako.’ (Agent)
- b. Nimotu-ga Ken-niyotte okur-are-ta.
 package-Nom Ken-by send-Pass-Past
 ‘The package was sent by Ken.’ (Source)
- c. Tegami-ga daihyoosya-niyotte uketor-are-ta.
 letter-Nom representative-by receive-Pass-Past
 ‘The letter was received by the representative.’ (Goal)
- d. [Sono bookun]-ga [ookuno simin]-niyotte
 [the tyrant]-Nom [many citizens]-by
 osorer-are-tei-ru.
 fear-Pass-Progressive-Pres
 ‘The tyrant is feared by many citizens.’ (Experiencer)

Since *niyotte* ‘by’ itself does not assign various θ -roles to its object as shown in (8), Hoshi’s (1994, 1999) claim that an external θ -role is suppressed in passives and that a *niyotte*-phrase optionally appears as an adverbial phrase is not consistent with this fact. This constitutes part of

the evidence that (1) does not represent the structure of passives.⁴

2.2.2. Accusative Case Assignment

As I have already discussed, structural accusative Case cannot be assigned in the structure of passives proposed in Chomsky (2001, 2008) and Hoshi (1994, 1999). In this subsection, however, I will present some passive sentences in which structural accusative Case is assigned.

2.2.2.1. The Passive of the DOC

First, we take up the passive of the DOC as in (9).

- (9) a. Mary was sent a letter. (IO-passive)
b. ?*A letter was sent Mary. (DO-passive)

(Larson (1988: 362–363))

For expository purposes, I will call sentences (9a) and (9b) “the IO-passive” and “the DO-passive,” respectively. The subject of the IO-passive is the indirect object (IO), while that of the DO-passive is the direct object (DO). In most dialects of English, the DO-passive is considered unacceptable. It has been assumed that this is because IO is assigned structural Case while DO is assigned inherent Case. This explanation supports the idea that structural accusative Case is never assigned in passives. Accordingly, it is only IO that can agree with T and be the subject of the passive DOC. On the other hand, DO does not

⁴ There may be a demoted external argument somewhere in the structure of passives. If such is the case, passive verbs must be able to assign the external θ -role, a property which the light verb *v* does not have. Hence, we must assume a structure of passives other than (1) in order to explain (5)–(8).

agree with T because inherent Case is still assigned in the passive.

According to Ura (2000), however, a DO-passive sentence like (9b) can be acceptable in British English, and Culicover and Jackendoff (2005) also admit that such a passive sentence is grammatical for some speakers at least. If their claim is correct, what assigns the Case to IO in the DO-passive and to DO in the IO-passive in that dialect of English?

In addition, Norwegian DOCs present a similar puzzle. In this language, we find both the IO-passive and the DO-passive, as in (10).⁵

(10) a. Marit ble gitt en bok. (IO-passive)

Mary was given a book

‘Mary was given a book.’

b. ??En bok ble gitt Marit. (DO-passive)

a book was given Mary

‘A book was given (to) Mary.’

Ura (2000) claims that both the Case of IO in the DO-passive and that of DO in the IO-passive are structural accusative Case in English and Norwegian. If so, we can claim that there is accusative Case assignment in passives.

A more obvious example of accusative Case assignment in passives can be found in Japanese. According to Miyagawa and Tsujioka (2004),

⁵ According to my Norwegian informant, a sentence like (10b) is not so acceptable. However, if we substitute the verb *tildele* ‘award’ for the verb *gi* ‘give,’ the DO-passive becomes fairly acceptable, as in (i).

(i) Prisen ble tildelt Marit.

prize.the was awarded Mary

‘The prize was awarded (to) Mary.’

(11) is the passive of the DOC in Japanese, and *nimotu* ‘package’ in (11) is assigned accusative Case.

- (11) Taroo-ga nimotu-**o** okur-are-ta.
Taro-Nom package-**Acc** send-Pass-Past
‘Taro was sent a package.’

(Miyagawa and Tsujioka (2004: 16))

They do not mention whether this accusative Case is structural or inherent, but they claim that the DO-passive as in (12) is not the passive of the DOC but the passive of the Prepositional Dative Construction (PDC) because (13) is unacceptable.

- (12) Nimotu-ga Taroo-niyotte Hanako-ni okur-are-ta.
package-Nom Taro-by Hanako-NI send-Pass-Past
‘The package was sent (to) Hanako by Taro.’ (ibid.: 19)

- (13) *Nimotu-ga Taroo-niyotte gakusei-ni futa-ri
package-Nom Taro-by students-NI 2-CL
okur-are-ta.
send-Pass-Past
‘A package was sent two students by Taro.’ (ibid.)

A numeral quantifier may float off its host only if the host is a DP. Considering this point, they claim that *gakusei-ni* ‘students-NI’ in (13) is not a DP but a PP and conclude that DO cannot be passivized in the DOC in Japanese.

However, most of my informants, who do not accept (13), accept the following sentences:

- (14) a. Tokubetusyoo-ga sootyoo-niyotte uti-no
 [special prize]-Nom president-by 1.pl-Gen
 gakusei-ni san-nin okur-are-ta.
 students-Dat 3-CL award-Pass-Past
 ‘The special prize was awarded (to) our three students by
 the president.’
- b. Sityoosya-ni sanzyuu-nin, terebikyoku-niyotte
 audiences-Dat 30-CL [television station]-by
 purezento-ga okur-are-ta.
 presents-Nom give-Pass-Past
 ‘(Lit.) (To) thirty audiences, the presents were given by
 the television station.’

Note that both *okur* ‘award’ in (14a) and *okur* ‘give’ in (14b) are homonyms of *okur* ‘send’ in (11)–(13). Some of my informants do not accept (14), but they give (14) the same score as the following active sentence of the DOC, which Miyagawa and Tsujioka (2004) treat as a grammatical sentence:

- (15) Taroo-ga gakusei-ni futa-ri nimotu-o okutta.
 Taro-Nom students-Dat 2-CL package-Acc sent
 ‘Taro sent two students a package.’

(Miyagawa and Tsujioka (2004: 7))

It seems natural to assume that those who do not accept (14) reject quantifier float from a dative argument itself. Given that sentences like (14) are acceptable for some speakers at least, IO in the DO-passive is not a PP but a DP. This contradicts Miyagawa and Tsujioka’s analysis.

Then, what is the difference between (13) and (14)? Consider the following examples:

- (16) a. Nimotu-ga Ken-niyotte kokkyoo-ni okur-are-ta.
package-Nom Ken-by border-to send-Pass-Past
'A package was sent to the border by Ken.'
- b. *Tokubetusyoo-ga syusyoo-niyotte kokkyoo-ni
[special prize]-Nom [Prime Minister]-by border-to
okur-are-ta.
award-Pass-Past
'The special prize was awarded to the border by the Prime Minister.'
- c. *Purezento-ga terebikyoku-niyotte kokkyoo-ni
presents-Nom [television station]-by border-to
okur-are-ta.
give-Pass-Past
'The presents were given to the border by the television station.'

According to Miyagawa and Tsujioka, the verb *okur* 'send' can take both the possessive goal, i.e. the DP variant of IO, and the locative goal, i.e. the PP variant of IO. The contrast between (16a) and (16b, c) shows that *okur* 'award' in (16b) and *okur* 'give' in (16c) cannot take the locative goal, and this is why *kokkyoo-ni* 'to the border' cannot appear in (16b, c).⁶ Thus, it seems possible that (12) and (13) are interpreted

⁶ A similar observation in English can be found in Rappaport Hovav and Levin (2008). They claim that *give*-type verbs only take possessional goals, while

either as the DOC or as the PDC, but let us assume that there is a strong preference for interpreting the DO-passive of the verbs that can take both the possessive goal and the locative goal to be the PDC.⁷ Thus, (12) and (13) can be interpreted only as the PDC. On the other hand, since verbs like *okur* ‘award’ and *okur* ‘give’ cannot take the locative goal, such verbs appear only in the DOC and are never used in the PDC. Accordingly, the sentences in (14) are interpreted as the DOC, and the IOs in (14) are DPs. Therefore, since DO can be passivized, as in (14), we can conclude that the accusative Case of DO is structural at least in the following passive sentences:

- (17) a. Hanako-ga sootyoo-niyotte tokubetusyoo-o
 Hanako-Nom president-by [special prize]-Acc
 okur-are-ta.
 award-Pass-Past
 ‘Hanako was awarded the special prize by the president.’

throw- and *send-*type verbs may also take spatial goals. This can be confirmed by the following contrast:

- (i) a. *Where did you give the ball?
 b. Where did you throw the ball? To third base.
 c. Where did you send the bicycle? To Rome.

(Rappaport Hovav and Levin (2008: 137))

*Give-*type verbs cannot be compatible with the locative *wh*-word *where*, but *throw-* and *send-*type verbs may be. I thank Koji Fujita (personal communication) for pointing this out to me.

⁷ In fact, judgments on (13) vary among my informants, although most of them judged (13) unacceptable. Thus, indeed there is a preference to interpret (12) and (13) to be the PDC, but some native speakers may interpret those sentences as the DOC. I am not sure why such a preference should exist, and I leave this issue for future research.

- b. Sityoosya-ga terebikyoku-niyotte purezento-o
 audience-Nom [television station]-by presents-Acc
 okur-are-ta.
 give-Pass-Past
 ‘The audience was given the presents by the television
 station.’

This means that structural accusative Case is assigned in the passive of the DOC in Japanese.

2.2.2.2. The Passive of the Possessor-Raising Construction

We can also find accusative Case assignment in the passive of the Possessor-Raising Construction, as in (18).

- (18) Naomi-ga Ken-niyotte atama-o tatak-are-ta.
 Naomi-Nom Ken-by head-Acc hit-Pass-Past
 ‘Naomi was hit on the head by Ken.’

Ken Hiraiwa (personal communication) points out to me that the accusative Case in (18) is structural. One might object to this idea because the active counterpart of (18) is unacceptable, as in (19), and this passive sentence may be classified as “the adversative passive.”

- (19) ??Ken-ga Naomi-o_i [e_i atama]-o tatai-ta.
 Ken-Nom Naomi-Acc head-Acc hit-Past
 ‘Ken hit Naomi on the head.’ (Hiraiwa (2008: 4))

If so, this might not be evidence for the claim that there is accusative Case assignment in passives. According to Hiraiwa (2008), however, the unacceptability of (19) can be avoided if scrambling is applied, as in

(20).

- (20) Naomi-o_i Ken-ga omoikkiri e_i atama-o tatai-ta.
Naomi-Acc Ken-Nom hard head-Acc hit-Past
'Ken hit Naomi hard on the head.' (Hiraiwa (2008: 7))

According to his analysis, in fact, the unacceptability of (19) comes from the Double-*o* Constraint (DoC, cf. Harada (1973)). Thus, (18) is a “regular” passive, and this supports the claim that structural accusative Case can be assigned in passives. Again, one might oppose this suggestion, since *atama* ‘head’ in (18) and (19) cannot be passivized, as in (21).

- (21) *Atama-ga_i Ken-niyotte Naomi-o t_i tatak-are-ta.
head-Nom Ken-by Naomi-Acc hit-Pass-Past
'(Lit.) The head was hit Naomi by Ken.'

If we assume that the possessee (*atama*) is lower than the possessor (*Naomi*) in the base position, we can conclude that the unacceptability of (21) arises precisely because of the problem of closeness. The possessee cannot undergo A-movement over the possessor.⁸ Consequently, (21) just violates the MLC (Minimal Link Condition). Furthermore, Hiraiwa (2008) claims that the DoC is a constraint only on structural accusative Case:

- (22) A Phase Theory of the DoC
Multiple identical occurrences of the structural accusative Case value cannot be morphophonologically realized within a single Spell-Out domain at Transfer. (Hiraiwa (2008: 13))

⁸ Ken Hiraiwa (personal communication) also suggests the same explanation.

This predicts that the DoC is irrelevant to (23) because the Case of *kyuuna saka* ‘steep slope’ in (23) is generally taken to be an instance of inherent Case.⁹

- (23) Ken-wa [kyuuna saka]-o zityensya-o
 Ken-Top [steep slope]-Acc bicycle-Acc
 issyookenmei osi-ta.
 hard push-Past
 ‘Ken pushed the bicycle hard on the steep slope.’

(Hiraiwa (2008: 5))

If his claim is correct, the accusative Case in (18) must be structural; otherwise, we cannot account for the unacceptability of (19).

2.2.2.3. The Ukrainian Passive

Finally, let us look at the Ukrainian passive. Ukrainian has an obvious example of accusative Case assignment in some passive sentences. The following is a case in point:¹⁰

- (24) Ja spodivajusja, [ščo cej žart ne bude
 I hope that this joke_{ACC} NEG will be
 vykorystano “Pravdoju Ukrajiny”].
 used_[-AGR] Pravda_{INST} of Ukraine
 ‘I hope that this joke won’t be used by *Ukrainian Pravda*.’

(Lavine and Freidin (2002: 259))

⁹ This inherent Case is called “the accusative of situation.”

¹⁰ Lavine and Freidin (2002) call an example such as (24) “Accusative Unaccusative.”

According to Lavine and Freidin (2002), some passive sentences in this language have an accusative subject, and the accusative Case in (24) is not inherent but structural. If Ukrainian has the same structure of passives as English, this is another piece of evidence for the claim that there is accusative Case assignment in passives. I will explain this phenomenon in section 2.4.

To summarize, in passives, an external argument must be implied, and accusative Case assignment is possible. On the other hand, unaccusative sentences do not have such properties. These properties of passives are consistent not with the light verb v in (1) but with the transitive light verb v^* in (2). Therefore, the structure of passives must not be the same as that of unaccusatives, as in (1). Rather, it should be similar to that of active transitive sentences.

2.3. Proposal

2.3.1. The Structure of Passives

If we assume the transitive light verb v^* in passives, then we must answer the question of which argument receives an external θ -role and which argument is assigned accusative Case. Recall that v^* assigns an accusative Case value and an external θ -role to some DP. In addition, we must consider how to raise an internal argument to the subject position, since v^*P is a phase and this raising seems to violate the Phase-Impenetrability Condition (PIC), as in (25).

(25) Phase-Impenetrability Condition

In phase α with head H, the domain of H is not accessible to

operations outside α , only H and its edge are accessible to such operations.

(Chomsky (2000: 108))

Matsuoka (2003) proposes that the *niyotte*-phrase of passives in Japanese is projected as specifier of the transitive light verb v^* , pointing out that it behaves as an argument.¹¹ He claims that the NP marked by *niyotte* ‘by’ in (26) is generated as an argument rather than as an adjunct, because it can serve as the antecedent of a reflexive anaphor, as in (26a), and induce a violation of Condition C, as in (26b).

- (26) a. Sono booru-ga John_i-niyotte karezisin_i-ni
 that ball-Nom John-by himself-Dat
 butuk-e-rare-ta.
 bump-LC-Pass-Past
 ‘That ball was bumped by John_i against himself_i.’
- b. *Sono booru-ga kare_i-niyotte [John_i-no kuruma]-ni
 that ball-Nom he-by John-Gen car-Dat
 butuk-e-rare-ta.
 bump-LC-Pass-Past
 ‘That ball was bumped by him_i against John_i’s car.’

(Matsuoka (2003: 177))

The structure of passives that he proposes is as follows:

- (27) [_{TP} T [_{v^* P} DP_j [_{v^*} DP_i-niyotte [_{v^*} v^* [_{VP} V t_j]]]]]]
-

¹¹ In Matsuoka (2003), the transitive light verb v^* is represented as v , but I use v^* to distinguish it from the light verb of unaccusatives.

Matsuoka (2003) adopts Chomsky's (2001) proposal that the head of v^*P optionally has an EPP-feature and triggers the movement of an internal argument to a specifier of v^*P and claims that DP_j , which is an internal argument, is raised to SPEC- v^* in (27).¹²

Although his analysis can explain why there is an implicit external argument in passives, two problems remain. Firstly, if the internal argument is raised to SPEC- v^* , which element will agree with v^* ? If the internal argument agrees with v^* , then it will be assigned an accusative Case value, contrary to fact. According to Chomsky (2001, 2008), v^* has the uninterpretable ϕ -features, and it must agree with an element that has matched interpretable ϕ -features; otherwise, the derivation crashes. One might propose that v^* loses its uninterpretable ϕ -features or its Case assigning property in passives.¹³ Given that such an analysis is correct, we cannot explain the fact that accusative Case is assigned in some passive sentences, as observed in section 2.2.2. Therefore, we must clarify how the uninterpretable ϕ -features of v^* are valued.

Secondly, what causes the head of v^*P to have an EPP-feature? If it can have an EPP-feature in the active, the following ungrammatical sentences will be generated:

¹² Note that this EPP-feature is different from the one that raises a *wh*-phrase to the outer SPEC- v^* , and that the position to which the internal argument is raised is an A-position.

¹³ Matsuoka (2001) proposes this kind of analysis. He assumes that the passive morpheme absorbs Case of a verb, and that this forces an internal argument to move to the specifier of IP.

- (28) a. *Hanako-ga Taroo-niyotte
 Hanako-Nom Taro-by
 nagur-ta. (nagur-ta → nagutta)
 hit-Past
 ‘(Lit.) Hanako hit by Taro.’
 (Intended meaning: ‘Hanako was hit by Taro.’)
- b. *Hanako-ga Taroo-ga nagur-ta. (nagur-ta → nagutta)
 Hanako-Nom Taro-Nom hit-Past
 ‘(Lit.) Hanako Taro hit.’
 (Intended meaning: ‘Hanako was hit by Taro.’ or ‘Taro hit Hanako.’)

Therefore, we must elucidate when the head of v^*P has an EPP-feature.

Jaeggli (1986) and Baker et al. (1989) propose that it is the passive morpheme *-en* that receives both an external θ -role and accusative Case. This means that what distinguishes the passive from the active is the existence of the passive morpheme. Taking this into consideration, I assume a projection above VP, which I call VoiceP, and I propose the following structure for both actives and passives:¹⁴

- (29) [v^*P EA [v^* [$VoiceP$ Voice [VP V IA]]]]

EA = external argument, IA = internal argument

¹⁴ In an earlier version of this study, I assumed VoiceP only in the structure of passives, which I called “PMP (Passive Morpheme Phrase).” I thank Koji Fujita (personal communication) for pointing out to me that I should also assume some VoiceP in actives if I assume one in passives. I also thank an anonymous reviewer for suggesting to me that I consider the possibility that IMP is also base-generated in SPEC- v^* .

The Voice of actives is $-\emptyset$, which is a phonetically null element, but the Voice of passives is the passive morpheme $-en$. I propose that $-en$ corresponds to $-(r)are$ in Japanese. The structure (29) means that v^* selects Voice itself under the bare phrase structure theory. Adopting Matsuoka's (2003) proposal, I suggest that IA in (29) is raised to SPEC- v^* above EA in passives, but that IA is not raised to that position in actives. In addition, I propose that EA in actives is DP, but that EA in passives is *IMP*, which is a phonetically null element.¹⁵ In order to support this proposal, I suggest the following conditions:¹⁶

- (30) a. v^* merges DP iff v^* selects $-\emptyset$.
- b. v^* merges *IMP* and is assigned an EPP-feature iff v^* selects $-en$.

EA in passives may overtly appear as a *niyotte*-phrase in Japanese. Following Matsuoka's observation as in (26), I suggest that in Japanese *IMP* may be realized as a *niyotte*-phrase, but that it is never realized as DP. This is why *niyotte*-phrases can bear various θ -roles, as in (8). In English, on the other hand, I propose that *IMP* cannot be realized as a

¹⁵ I suggest that *IMP* corresponds to PRO or *pro*, adopting Fujita's (1994) analysis.

¹⁶ An anonymous reviewer suggests the possibility that $-en$ in fact has the EPP-feature and that $-en$ -to- v^* movement enables v^* to have the EPP-feature. This suggestion can explain why v^* is not assigned an EPP-feature if it selects $-\emptyset$. However, it is unclear why IA is not raised until $-en$ adjoins to v^* if $-en$ originally has the EPP-feature. The landing site of IA would be specifier of $-en$ rather than SPEC- v^* in that case. Another possibility is that v^* originally has an EPP-feature that requires merging an element with a phonetic form, which is satisfied by the External-Merge of EA in the active. However, EA in the passive is *IMP*, which is phonetically null. Thus, the Internal-Merge of IA is required. For now, I leave this issue for future research.

by-phrase, which appears as an adverbial phrase, and that the θ -role of the *by*-phrase is transferred from IMP as we have observed in section 2.2.1. This proposal is basically the same as Fox and Grodzinsky's (1998) assumption that θ -transmission involves the transmission of a θ -role that is otherwise realized by an implicit argument.¹⁷ Moreover, the conditions in (30) can exclude sentences like (28). Since v^* selects $-\emptyset$ in (28), v^* cannot merge the *niyotte*-phrase nor be assigned an EPP-feature that raises IA to SPEC- v^* above EA.¹⁸

To sum up, the structure of the active transitive sentence is (31), and its passive counterpart is (32).

(31) a. John hit Mary.

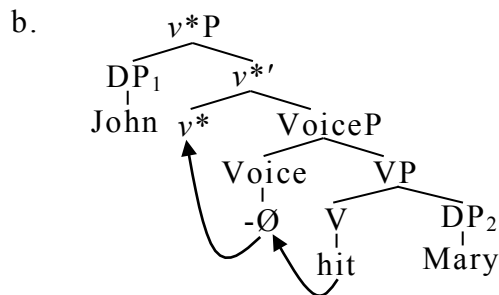

¹⁷ For the interpretation of *by*-phrases and its relationship with children's difficulty with passive constructions, see Fox and Grodzinsky (1998).

¹⁸ Koji Fujita (personal communication) points out to me that the condition (30b) can also exclude the following sentence:

- (i) *Taroo-ga Hanako-o nagur-are-ta.
 Taro-Nom Hanako-Acc hit-Pass-Past
 (Intended meaning: 'Taro hit Hanako.')

This is because v^* in (i) merges the DP *Taroo* and is not assigned an EPP-feature, although it selects *-en*.

(32) a. Mary was hit (by John).

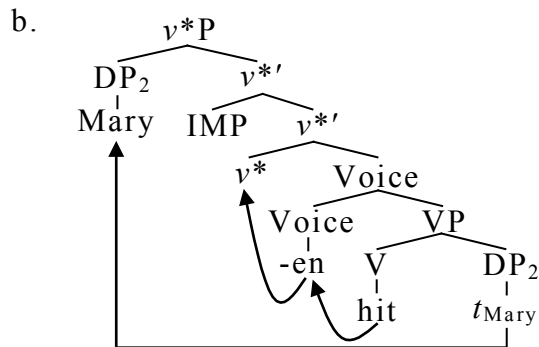

In (31), VP is selected by $-\emptyset$, and then VoiceP is selected by v^* . As I have mentioned above, v^* has the Agree feature (the uninterpretable ϕ -features), which agrees with DP₂ *Mary*, and v^* assigns an accusative Case value to DP₂. v^* also assigns an external θ -role to its specifier; thus, DP₁ *John* receives this θ -role. On the other hand, in (32), the passive morpheme *-en* is the head of VoiceP. This VoiceP is selected by v^* , and v^* merges IMP. v^* assigns an external θ -role to IMP, and it functions as an implicit external argument in passives. Moreover, DP₂ *Mary* is raised to SPEC- v^* by the EPP-feature of v^* . T agrees with DP₂, and DP₂ is raised to SPEC-T in the later derivation. In both (31) and (32), I propose that V adjoins to Voice, and that V-Voice complex adjoins to v^* .

However, the question of which element agrees with the Agree feature of v^* remains unsolved. I will answer this question in the next subsection.

2.3.2. Two Chains

As I have discussed above, we obtain one A-chain of DP₂ in (32)

when DP_2 is raised to SPEC- v^* . In addition to this A-chain, I suggest that there is another A-chain in (32).

In the derivation of an active transitive sentence like (31), Chomsky (2008) claims that the Agree feature of v^* is inherited by V, and that DP_2 must be raised to SPEC-V in (31). It follows that we obtain one A-chain through the agreement between v^* -V and DP_2 in (31), as illustrated below:

$$(33) \quad [v^* \dots [_{VP} DP_2 [_{V'} V t_{DP_2}]]]$$

What about the derivation of passives? Although I have suggested that DP_2 agrees with the EPP-feature of v^* and is raised to SPEC- v^* , DP_2 in fact agrees with the Agree feature of v^* at the same time, if we adopt the Principle of Simultaneity proposed by Hiraiwa (2005).

(34) The Principle of Simultaneity

Apply operations simultaneously in parallel at a probe level.

(Hiraiwa (2005: 44))

According to Hiraiwa's proposal, (34) is a principle that conforms to the Earliness Principle presented by Pesetsky (1989). If we assume v^* in the derivation of passives and it agrees with DP_2 , the same A-chain as in (33) must also exist in (32). This means that two A-chains are created simultaneously in the derivation of passives, as shown in (35).¹⁹

¹⁹ Masao Ochi (personal communication) points out to me that it seems redundant that V "reemerges" DP_2 at its specifier because the relationship between V and DP_2 does not change after the raising of DP_2 to SPEC-V in both (33) and (35). I basically agree with this, but what I would like to stress here is that we have two relationships between v^* and DP_2 ; one is related with the

$$(35) \quad [{}_{v^*P} DP_2 [{}_{v^*'} IMP [{}_{v^*'} v^* \dots [VP DP_2 [V' V t_{DP_2}]]]]]$$

The derivation shown in (35), however, appears to have one problem: these two A-chains have different Case values. As I illustrate in (36), Chain (I) has the accusative Case value, but Chain (II) does not have any Case value:

$$(36) \quad [{}_{v^*P} DP_2 [{}_{v^*'} IMP [{}_{v^*'} v^* [VoiceP Voice [VP DP_2 [V' V t_{DP_2}]]]]]]]$$

One might wonder whether such a derivation is possible, but we can observe a similar movement in the derivation of a sentence like (37).

(37) Who saw John?

Chomsky (2008) claims that the Agree feature of C is also inherited by T, and that *who* is raised from SPEC- v^* to SPEC-T and SPEC-C at the same time in the derivation of (37). This is because the Agree feature, inherited by T from C, raises *who* to SPEC-T, while the EF (edge-feature) of C raises it to SPEC-C. The result is (38).

$$(38) \quad \text{who} [C [\text{who} [T [\text{who } v^* [\text{see John}]]]]]$$

In (38), Chain (I) has the nominative Case value, but Chain (II) does not have any Case value. In order to account for these phenomena, I propose the following principle:

(39) The Case Value Selection Principle

If two Chains are created simultaneously, either Case value is

Agree feature of v^* and the other with the EPP-feature of v^* . For expository purposes, I keep assuming that DP_2 is raised to SPEC-V.

selected at Transfer.

If the value of Chain (II) is selected in (38), *who* does not have any Case value at Transfer and this derivation crashes at the interface level. On the other hand, if the value of Chain (I) is selected, *who* has the nominative Case value at Transfer and this derivation converges. Consequently, only selecting the value of Chain (I) is possible in (38).

I suggest that the principle (39) can also be applied to the derivation (36). If the value of Chain (I) is selected in (36), DP_2 has the accusative Case value at Transfer. This means that DP_2 has already been assigned a Case value and become inactive at the v^*P phase-level, and that T cannot agree with DP_2 at the CP phase-level. Thus, the Agree feature, inherited by T from C, cannot agree with any element, and this causes the derivation to crash. On the other hand, if the value of Chain (II) is selected, DP_2 has no Case value at the v^*P phase-level, and it can agree with T. Therefore, this derivation converges. One might ask why it is not a problem that DP_2 does not have any Case value at the Transfer of the v^*P phase. This is because A-movement does not leave a trace/copy, as proposed in Lasnik (1999a). The copies of DP_2 transferred at the v^*P phase-level are the lower copies, which are deleted, while the copy at SPEC- v^* is not transferred at the v^*P phase-level, since it is at the edge of v^* . Consequently, the principle (39) is valid, and only selecting the value of Chain (II) is possible in the derivation (36).

In the next section, I will show that the structure of passives I have proposed here can adequately explain the phenomena we observed in section 2.2.

2.4. Some Consequences

2.4.1. Presence of an Implicit Argument

As I have discussed in section 2.3, the transitive light verb v^* exists in the derivation of passives. This tells us why passives can be compatible with a rationale clause while unaccusatives cannot, as in (5), which is repeated in (40).

(40) a. The ship was sunk to collect the insurance. (passive)

b. *The ship sank to collect the insurance. (unaccusative)

Recall that this difference depends on whether there is an implicit external argument. One of the properties of v^* is to assign an external θ -role to some argument. In the structure of passives I proposed in (32), this θ -role is assigned to IMP, and it functions as an implicit external argument. On the other hand, I suggest that the structure of unaccusatives is (41).

(41) a. The ship sank.

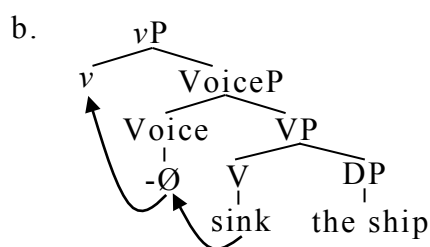

Since (41a) is an active sentence, VP is selected by $-\emptyset$, and then VoiceP is selected by v . The light verb v assigns neither an external θ -role nor any Case value. Accordingly, there is no implicit argument involved in unaccusatives. The DP *the ship* is assigned a nominative Case value by

T in the later derivation because vP is not a phase.²⁰

Therefore, what distinguishes passives from unaccusatives is the existence of v^* in the structure.

2.4.2. Absence of Passive Unaccusative

In this subsection, I would like to answer the question why there is no passive unaccusative. This question may sound strange, but if the sentence (42a) is an active sentence, there seems to be no a priori reason why its passive counterpart (42b) should be excluded.

²⁰ It has been known that the unaccusative also behaves differently from the middle as follows:

- (i) a. The boat sank all by itself.
- b. *Bureaucrats bribe easily all by themselves.

(Keyser and Roeper (1984: 405))

According to Keyser and Roeper (1984), *all by itself* in (ia) means “totally without external aid.” This notion reflects that there is no external argument in unaccusatives, but some implicit external argument exists in middles. We can predict this difference if we assume the structure of middles as shown in (iia) and the condition (iib), in addition to the conditions in (30).

- (ii) a. [v^*P bureaucrats_i [v^* IMP_{arb} [v^* v^* [VoiceP -MID [VP bribe t_i]]]]]]
- b. v^* merges IMP_{arb} and is assigned an EPP-feature iff v^* selects -MID.

I propose that IMP_{arb} is basically the same as PRO_{arb} proposed in Stroik (1995), and that the head of VoiceP in middles is -MID. Although both \emptyset and -MID are phonetically null elements in English, according to Fujita (1994), these two morphemes are phonetically different in Japanese where we have the paradigm of *kowas* ‘transitive break’ and *kowas-er* ‘middle break.’ I also suggest that middles cannot be compatible with rationale clauses because middle sentences are generally stative. The stative reading in middles may come from -MID, but I leave this issue for future research.

- (42) a. Fune-ga sizum-ta. (sizum-ta → sizunda)
 ship-Nom sink-Past
 ‘The ship sank.’
- b. *Fune-ga (Ken-niyotte) sizum-are-ta.
 ship-Nom (Ken-by) sink-Pass-Past
 ‘(Lit.) The ship was affected (by Ken) letting it sink.’
- c. Fune-ga (Ken-niyotte) sizum-er-are-ta.
 ship-Nom (Ken-by) sink-LC-Pass-Past
 ‘The ship was sunk (by Ken).’

In the literature (e.g. Jaeggli (1986)), it has been stated that the passive morpheme is an argument that receives an external θ -role and accusative Case; thus, it can be compatible with only verbs that assign both of them.²¹ This notion can be captured in the present framework by assuming the selectional restriction of light verbs, as in (43).

- (43) v^* may select *-en*, but v may not.

(43) can exclude (42b) because the light verb of (42b) is v and it may not select the passive morpheme. On the other hand, since the light verb of (42c) is v^* , it may select the passive morpheme and (42c) is grammatical. This is why there is no passive unaccusative.

One might point out that the unaccusative verb *arrive* can appear in passives, as in (44).

- (44) The solution was arrived at.

(Hornstein and Weinberg (1981: 86))

²¹ According to Fujita and Matsumoto (2005), not only transitive verbs but unergative verbs also have such properties.

According to my informants, however, (44) is different from a “true” unaccusative sentence like (45a), since we can find a difference between (46a, b).

- (45) a. John arrived at the station.
b. *The station was arrived at.
- (46) a. There arrived a man at the station.
b. *There arrived a man at the solution.

I assume that *arrive* in (44) should be classified as a kind of unergative verb licensing the construction of pseudopassive.

2.4.3. v^* and Accusative Case Assignment

In the previous subsections, we have seen that v^* must exist in the derivation of passives because one of the properties of v^* , that of external θ -role assignment, is consistent with the behavior of passives. In the remaining subsections, I will focus on the other property of v^* , namely accusative Case assignment.

2.4.3.1. The Passive of the DOC

In this subsection, I focus on the passive of the DOC. As we have seen in section 2.2.2.1, there seems to be structural accusative Case assignment in the passive of the DOC in those dialects and languages where both the IO-passive and the DO-passive are possible. I would like to discuss whether structural accusative Case assignment is possible in passives. Therefore, I will treat only the DOCs of languages where both passives are acceptable.

First, I propose the structure of the active DOC as in (47).

(47) a. John gave Mary a book.

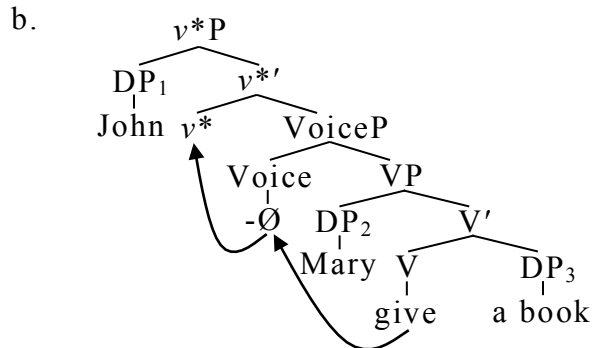

In (47), I suggest that v^* agrees with DP_2 and DP_3 simultaneously, adopting Multiple Agree proposed by Hiraiwa (2005), as in (48).

(48) MULTIPLE AGREE (multiple feature checking) with a single probe is a single simultaneous syntactic operation; AGREE applies to all the matched goals at the same derivational point *derivationally simultaneously*.

(Hiraiwa (2005: 38))

This is why both DPs have the same Case value, namely the accusative Case value.

According to Hiraiwa (2005), however, the two goals that agree with the same probe do not necessarily have the same Case value. The following are examples of nominative-genitive conversion in the Possessor-Raising Construction in Japanese:

(49) a. John-**ga** se-**ga** taka-i riyuu
 John-Nom height-Nom high-Prs.Adn reason
 ‘the reason why John is so tall’ [Nom-Nom]

- b. John-**no** se-**ga** taka-i riyuu
 John-Gen height-Nom high-Prs.Adn reason
 ‘the reason why John is so tall’ [Gen-Nom]
- c. John-**ga** se-**no** taka-i riyuu
 John-Nom height-Gen high-Prs.Adn reason
 ‘the reason why John is so tall’ [Nom-Gen]
- d. John-**no** se-**no** taka-i riyuu
 John-Gen height-Gen high-Prs.Adn reason
 ‘the reason why John is so tall’ [Gen-Gen]

(Hiraiwa (2005: 119–120))

He suggests that *John* and *se* ‘height’ in (49) Multiple-Agree with the same probe, and that the actual values of Case are determined at Transfer; therefore, the nominative and genitive Case values are freely assigned.

If the same thing happens to the DOC in Japanese, we can claim that *Hanako* and *tokubetusyoo* ‘special prize’ in (50) Multiple-Agree with the same probe, namely v^* .²²

- (50) Sootyoo-ga Hanako-ni tokubetusyoo-o
 president-Nom Hanako-Dat [special prize]-Acc
 okur-ta. (okur-ta → okutta)
 award-Past

²² I am not sure why dative and accusative Case values cannot be freely assigned in the DOC in Japanese. However, freedom of Case value assignment is not a necessary condition for Multiple Agree. According to Ken Hiraiwa (personal communication), it is possible to assume that both *Hanako* and *tokubetusyoo* ‘special prize’ Multiple-Agree with v^* in (50).

‘The president awarded Hanako the special prize.’

Accordingly, I propose that some dialects of English and Japanese have the same structure of the DOC as in (47).²³

2.4.3.1.1. The Structure of the Passive DOC

Now, let us apply the structure of passives proposed in section 2.3 to the DOC. As we have seen, the head of VoiceP *-en* selects VP in passives. Thus, I propose that the structure of the passive DOC is (51).

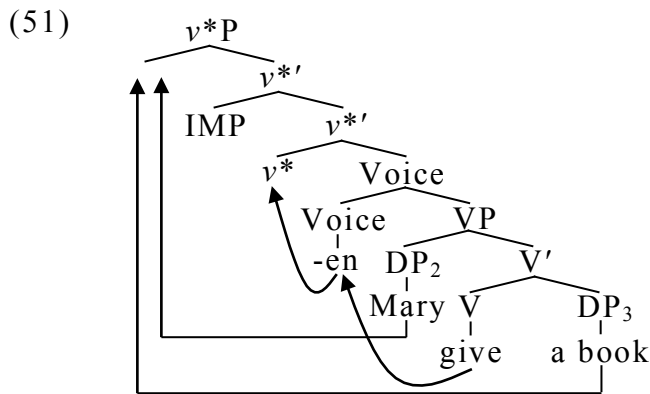

Under the Principle of Simultaneity and Multiple Agree, v^* agrees with DP_2 and DP_3 simultaneously in (51). However, as I have proposed in section 2.3, the element that is raised to SPEC- v^* will not have a Case value because the Chain that has no Case value is selected to agree with T in the later derivation. Furthermore, if we follow Chomsky’s (1995) notion of equidistance as in (52), DP_2 and DP_3 are equidistant from v^* , since both DPs are in the same minimal domain.

(52) γ and β are equidistant from α if γ and β are in the same minimal domain. (Chomsky (1995: 356))

²³ I also suggest that the structure of the DOC in Norwegian is the same as (47).

Consequently, either DP can be raised to SPEC- v^* by the EPP-feature of v^* , and we can obtain both the IO-passive and the DO-passive in some dialects of English, Japanese, and Norwegian, where the structure of the passive DOC is (51). In both passives, the DP that is not raised to SPEC- v^* is assigned the same Case value as in the active because it agrees with v^* not only in the active but also in the passive. We can verify this from the examples of Japanese DOCs, as in (53).

- (53) a. Sootyoo-ga Hanako-**ni** tokubetusyoo-**o**
 president-Nom Hanako-**Dat** [special prize]-**Acc**
 okur-ta. (okur-ta → okutta)
 award-Past
 ‘The president awarded Hanako the special prize.’
 (active)
- b. Hanako-ga sootyoo-niyotte tokubetusyoo-**o**
 Hanako-Nom president-by [special prize]-**Acc**
 okur-are-ta.
 award-Pass-Past
 ‘Hanako was awarded the special prize by the president.’
 (IO-passive)
- c. Tokubetusyoo-ga sootyoo-niyotte Hanako-**ni**
 [special prize]-Nom president-by Hanako-**Dat**
 okur-are-ta.
 award-Pass-Past
 ‘The special prize was awarded (to) Hanako by the
 president.’ (DO-passive)

This supports the claim that v^* exists even in the structure of passives; otherwise, these phenomena cannot be explained. In addition to these Japanese examples, we can answer why the Case values of the non-subject arguments in the IO-passive and the DO-passive are the same as in the active counterpart in some dialects of English and Norwegian.²⁴

2.4.3.1.2. The Case of DO: Inherent vs. Structural

We have seen that the structure (51) can derive both passives of the DOC. In fact, we can find examples of both in certain dialects and languages. I have assumed that IO and DO are assigned structural Case in those dialects and languages, but I would like to confirm whether this is correct in order to prove that v^* assigns these Case values. Most researchers admit that IO is assigned structural Case in English, Japanese, and Norwegian. On the other hand, some researchers claim that DO is assigned inherent Case, and this is claimed to be the reason for the marginality of the DO-passive in most dialects of English.

²⁴ Ken-ichi Takami asks me how one can account for the unacceptability of the following example with the structure (51):

- (i) ?*Bob was knit a sweater by Sam. (Pinker (1989: 221))

This is an example of the passive of so-called *for*-dative verbs. Interestingly, Pinker (1989) claims that these verbs show piecemeal passivizability, and that not all *for*-dative verbs are unpassivizable. He proposes that this phenomenon is related to the patienthood of IO. In addition, Goldberg (2002) states that the following passive sentence is acceptable, although the verb *cook* is a *for*-dative verb:

- (ii) Mel was cooked a fine dinner by the new chef.
(Goldberg (2002:331))

Thus, I assume that this problem is irrelevant to syntax, but I leave this for future research.

Here I would like to claim that DO is actually assigned structural Case even in those dialects of English where the DO-passive is unacceptable. There are some cases in which an inherent Case argument is the subject. The most well-known example is the Icelandic quirky subject, as in (54).²⁵

(54) Henni leiddust/*?leiddist þeir.

her_{Dat.3.sg} bored_{3.pl/3.sg} they_{Nom.3.pl}

‘She was bored with them.’ (Taraldsen (1995: 307))

Here, the Case of *henni* ‘her’ is inherent quirky dative. Notice that this inherent Case subject does not agree with T.²⁶ If inherent Case subjects are generally unable to agree with T, DO will not agree with T in the passive DOC in those dialects where the DO-passive is acceptable. Contrary to this prediction, as we see in (55), which are British English examples, T agrees with DO in the DO-passive of the DOC.

(55) a. The book was given Mary (by John).

b. These letters were sent Mary (by John). (Ura (2000: 247))

Thus, it is untenable to claim that DO in the DOC is assigned inherent Case in those dialects of English in which the DO-passive is acceptable. Moreover, most of those who do not accept the DO-passive alter their judgments if IO is a pronoun, as illustrated in (56).²⁷

²⁵ See also Boeckx (2000: 358).

²⁶ According to Hiraiwa (2005), “default” agreement obtains in a structure where T’s only goal is a quirky element or its goals have different feature values.

²⁷ It is assumed that this is because an unstressed pronoun in English behaves as a clitic in syntax.

(56) a. The book was given her (by John).

b. These letters were sent her (by John). (Ura (2000: 247))

Again, DOs in (56) agree with T. Therefore, we can conclude that DO is assigned structural Case in the DOC in most dialects of English.

To summarize this subsection, there must be accusative Case assignment in passives at least in some dialects and languages where the DO-passive is acceptable, and this is only possible if we assume v^* in the structure of passives, although problems remain with respect to why the DO-passive is often unacceptable (see Amano (1998) and Ura (2000) for discussion).

2.4.3.2. The Passive of the Possessor-Raising Construction

As I have discussed in section 2.2.2.2, the passive of the Possessor-Raising Construction in Japanese, as in (18), which is repeated in (57), gives us another piece of evidence for the claim that accusative Case is assigned in passives.

(57) Naomi-ga Ken-niyotte atama-**o** tatak-are-ta.

Naomi-Nom Ken-by head-**Acc** hit-Pass-Past

‘Naomi was hit on the head by Ken.’

Again, the active counterpart of (57) is not acceptable, as illustrated in (58) (= (19)), but this unacceptability comes from the DoC.

(58) ??Ken-ga Naomi-o_i [_{e_i} atama]-o tatai-ta.

Ken-Nom Naomi-Acc head-Acc hit-Past

‘Ken hit Naomi on the head.’

Recall that the DoC effect is triggered when multiple identical

occurrences of the structural accusative Case value are morphophonologically realized within a single Spell-Out domain at Transfer.

According to Mihara and Hiraiwa (2006), in (58), *Naomi* and *atama* ‘head’ are in the same Spell-Out domain, and they Multiple-Agree with the same probe and are assigned structural accusative Case. Consequently, more than one structural accusative Case is morphophonologically realized within the same Spell-Out domain. This violates the DoC; hence, the unacceptability of (58).

At the same time, this means that the DoC effects can be obviated if there is only one accusative element in the same Spell-Out domain. As we have observed in section 2.2.2.2, scrambling of one of the accusative elements to the sentence-initial position or to the position in front of various *v**P/VP adverbs (e.g. *omoikkiri* ‘hard’) suppresses the DoC effects. Moreover, Hiraiwa (2008) points out that the DoC effects can be obviated by replacing one of the accusative Case-particles with a focus particle, as shown in (59).

(59) PF Case-suppression

- a. Ken-ga Naomi-*mo/dake/sae/wa*_i [*e*_i atama]-*o*
 Ken-Nom Naomi-also/only/even/Top head-Acc
 tatai-ta.
 hit-Past
 ‘Ken hit also/only/even Naomi on the head.’
- b. Ken-ga Naomi-*o*_i [*e*_i atama-*mo/dake/sae/wa*]
 Ken-Nom Naomi-Acc head-also/only/even/Top

tatai-ta.

hit-Past

‘Ken hit Naomi also/only/even on the head.’

(Hiraiwa (2008: 8))

From these facts, we can conclude that the Multiple Agree in (58) itself does not trigger the DoC effects, but that only the morphophonological realization of more than one structural accusative Case within a single Spell-Out domain violates the DoC.

Furthermore, Hiraiwa (2008) proposes (60) as the structure of (58).^{28, 29}

(60)

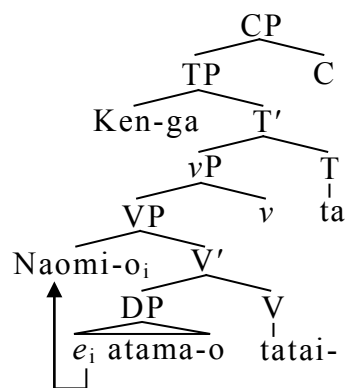

(ibid.: 14)

Adapting this structure to the current passive structure, I propose (61) as the structure of (57).

²⁸ In Hiraiwa (2008), the transitive light verb v^* is represented as v .

²⁹ Mihara and Hiraiwa (2006) assume another projection “AspP” between v and VP, and they propose that the possessor (*Naomi*) and the possessee (*atama* ‘head’) are in the following configuration:

(i) [_{AspP} Naomi_i [_{Asp'} [_{VP} [_{DP} t_i atama] V] Asp]]

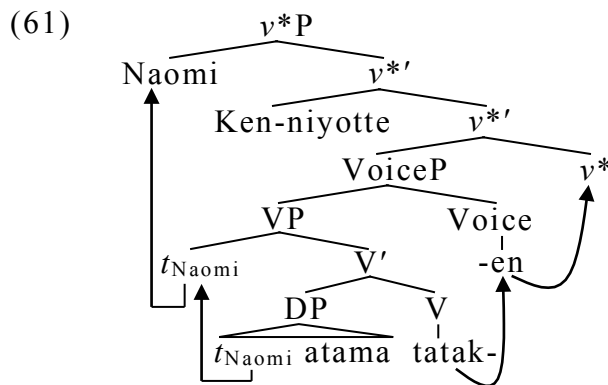

In the derivation (61), VP is selected by the head of VoiceP *-en* as I have discussed, and this VoiceP is selected by v^* . Then, v^* merges the *niyotte*-phrase. *Ken-niyotte* ‘by Ken’ is assigned the external θ -role by v^* . Although *Naomi* and *atama* ‘head’ Multiple-Agree with v^* , *Naomi* is raised to SPEC- v^* by the EPP-feature of v^* and will not have a Case value because the Chain with no Case value is selected to agree with T in the later derivation. On the other hand, *atama* ‘head’ is assigned accusative Case just as in its active counterpart.

This phenomenon also requires the assumption that v^* exists in the passive structure. If we do not assume v^* in passives, we cannot explain why *atama* ‘head’ in (57) is assigned structural accusative Case.

2.4.3.3. The Ukrainian Passive

Finally, I would like to discuss the example of the Ukrainian passive as in (24), which I repeat here as (62).

- (62) Ja spodivajusja, [ščo cej žart ne bude
 I hope that this joke_{ACC} NEG will be
 vykorystano “Pravdoju Ukrajinj”].
 used_[-AGR] Pravda_{INST} of Ukraine

‘I hope that this joke won’t be used by *Ukrainian Pravda*.’

[-AGR] in (62) means “no-agreement,” and Lavine and Freidin (2002) point out that this language has T that lacks agreement features while retaining the EPP-feature. They propose that *cej žart* ‘this joke’ in (62) is assigned the accusative Case value by *v*, which corresponds to *v** in the present framework, and that T’s EPP-feature raises it to SPEC-T. They suggest that the derivation of (62) is like (63).

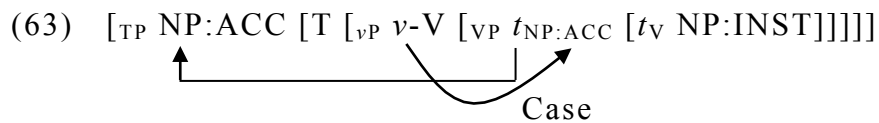

They claim that this movement is distinguished from the discourse-oriented short-distance scrambling of arguments. They also state that scrambling disrupts focus projection, but that the displacement of the internal argument does not disrupt focus projection in (62). In addition, only the structurally Case-marked direct object undergoes Genitive of Negation (GenNeg). This is a syntactic operation where the direct object is obligatorily marked genitive (GEN) when it is lower than NEG. In contrast, lexically Case-marked NPs fail to undergo such a process. They point out that the direct object in a sentence like (62) undergoes GenNeg, as illustrated in (64), and that this is the evidence that *cej žart* ‘this joke’ in (62) is assigned structural accusative Case.³⁰

31

³⁰ Here I do not discuss the word order in (64). See Lavine and Freidin (2002) for details.

³¹ The gloss of (64) is quoted from Lavine and Freidin (2002: 267).

- (64) Na druhýj den' ne bulo najdeno joho čovna.
on next day NEG was found_[-AGR] his boat_{GEN}
‘On the following day his boat wasn’t found.’

(Shevelov (1969: 177))

However, if we assume that structural Case is assigned only by a probe, *v* is a probe and *v*P corresponds to a phase in (63). It follows that T, which is outside the phase *v*P, cannot access NP:ACC due to the PIC. Accordingly, T’s EPP-feature is not satisfied and this derivation crashes, contrary to fact. We thus have to conclude that the derivation (63) is untenable.

In contrast, the present passive structure can derive (62) without violating the PIC. Recall the Case Value Selection Principle in (39), which is repeated as (65).

- (65) The Case Value Selection Principle

If two Chains are created simultaneously, either Case value is selected at Transfer.

We have two Chains of NP:ACC, as I show in (66).³²

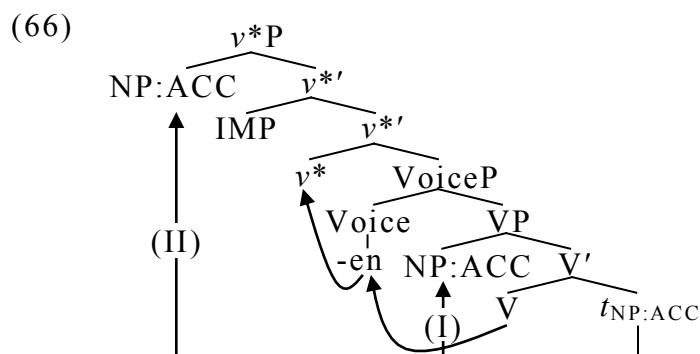

In section 2.3.2, I have proposed that the Case value of Chain (II) is

³² I omit NP:INST for the sake of simplicity.

selected in passives in English, Norwegian, and Japanese. In the Ukrainian passive, however, I propose that the Case value of Chain (I) is selected. This is because T lacks agreement features in this kind of passive and NP:ACC will not be assigned any Case value through the derivation if the value of Chain (II) is selected. The value of Chain (I) must be selected so that the derivation can converge. In addition, NP:ACC is raised to SPEC- v^* by the EPP-feature of v^* . Therefore, T can access NP:ACC without violating the PIC, and it is raised to SPEC-T by T's EPP feature if we adopt Lavine and Freidin's (2002) claim that an NP whose Case has been valued previously is not necessarily frozen in place.

This phenomenon cannot be explained without assuming v^* in the structure of the passive; otherwise, we have no way of assigning an accusative Case value in a sentence like (62). This fact is another piece of evidence to support my proposal.

2.5. SPEC- v^* and Expletives

We have seen that the structure of passives in (32), repeated as (67), can predict various phenomena of passives that are not consistent with the structure in (1), whose tree diagram version I illustrate in (68).

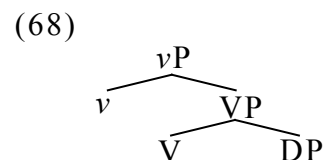
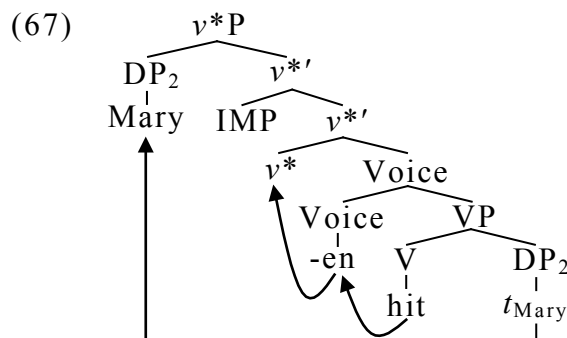

Nevertheless, (67) appears to have some problems, and (68) might be superior to (67). As I have mentioned in section 2.3, v^* in (67) is assigned an EPP-feature, and it may follow that expletives can be External-Merged at SPEC- v^* above IMP, and that DP_2 cannot be raised to that position in such a derivation. There are two expletives in English, namely, *there* and *it*. Consider the case where the expletive *there* is External-Merged at SPEC- v^* . This type of derivation is excluded because the element that can agree with T is only the expletive *there*, and it does not have all ϕ -features to value T's uninterpretable ϕ -features (see Chomsky (2001, 2004)).^{33, 34} However, the expletive *it* has enough ϕ -features to value T's uninterpretable ϕ -features. It seems possible to External-Merge the expletive *it* at SPEC- v^* . If this were the case, the following ungrammatical sentence would be grammatical, contrary to fact:

(69) *It was expected Sue's late arrival.

(Pesetsky and Torrego (2001: 356))

Miyagawa (2008) distinguishes v^*P/vP from CP and calls the former *Argument Structure* and the latter *Expression Structure*. In order to exclude (69), I suggest the following condition:

(70) Expletives cannot be External-Merged in Argument

³³ I suggest that IMP (or a *niyotte*-phrase in Japanese) does not have an uninterpretable Case-feature and is inactive when T merges with v^*P .

³⁴ I propose that the expletive *there* is External-Merged at SPEC-T, and that the internal argument *a book* is Internal-Merged at SPEC- v^* in (ib).

(i) a. *There has been put a book on the table.

b. There has been a book put on the table. (Lasnik (1999b: 88))

See also Julien (2006) for discussion.

Structures.

An Expression Structure is necessarily accompanied by an Argument Structure. Accordingly, an expletive can always have its associate in the Argument Structure as soon as it is External-Merged in the Expression Structure. Moreover, when an expletive in the Expression Structure is *Internal-Merged* into the higher Argument Structure, it can be treated in the same way as an argument, since it always has its associate in the lower Argument Structure. On the other hand, if an expletive is External-Merged in the Argument Structure, there is no chance for the expletive to have its associate. Such a derivation crashes at the interface. Therefore, I propose that expletives are introduced into the derivation only to satisfy the requirement in Expression Structures. If the condition (70) is on the right track, expletives are never External-Merged at SPEC-*v** in passives, and an internal argument must be Internal-Merged at that position. Accordingly, the element that agrees with T is the internal argument, and the expletive *it* cannot be merged at SPEC-T in this type of sentence. This is why (69) is ungrammatical. In (69), the internal argument *Sue's late arrival* is Internal-Merged at SPEC-*v**. Then, T agrees with it, and there is no chance of merging the expletive *it*.

One might claim that (70) also appears to exclude the following grammatical sentence, contrary to fact:

(71) It was expected that Sue would arrive late.

(Pesetsky and Torrego (2001: 356))

However, we can consider that the expletive *it* in (71) is in fact

Internal-Merged at SPEC- v^* , as in (72), and that it is not External-Merged at SPEC- v^* , since we can obtain its active counterpart as in (73).^{35, 36, 37}

³⁵ As we will see in chapter 4, Stroik (1996) assumes the expletive *it* to be base-generated at the specifier of CP. In this chapter, however, I tentatively assume the projection XP, which takes the expletive *it* as its specifier and CP as its complement in (72).

³⁶ We can find many examples like (73). The following sentences are all taken from *the British National Corpus* < <http://bnc.jkn21.com/>>:

- (i) ... I would have thought it that the message would have got over to me honourable members before now.
- (ii) Now all the others are telling it that it's got to be the one to welcome the Ship.

³⁷ An anonymous reviewer asks whether the analysis here is also compatible with the following examples:

- (i) a. It was surprising that John came back at midnight.
- b. It isn't certain who came to the party.

It seems natural to assume that the derivation of (i) differs from that of (ii) only in that the expletive *it* is included in the numeration in the former but not in the latter.

- (ii) a. That John came back at midnight was surprising.
- b. Who came to the party isn't certain.

Both (i) and (ii) are active sentences. Hence, I propose that (ia) and (iia) have the same derivation as in (iii).

- (iii) [_{CP1} C [_{TP} α [T [_{vP} v [_{voiceP} - \emptyset [_{VP} be [_{AP} surprising [_{CP2} that ...]]]]]]]]]]

To satisfy T's EPP-feature, the expletive *it* is External-Merged at α in (ia), and CP₂ is Internal-Merged at α in (iia). In (iii), CP₁, which includes TP, corresponds to an Expression Structure, and vP corresponds to an Argument Structure, which contains CP₂. Accordingly, the derivation of (i) does not violate the condition in (70) because α is a position in the Expression Structure.

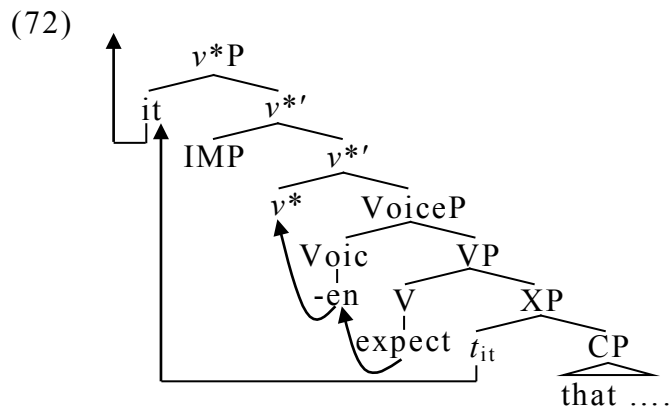

(73) Someone expected it that Sue would arrive late.

Furthermore, if the expletive *it* is not included in the numeration, then *that Sue would arrive late* is Internal-Merged at SPEC- v^* and it agrees with T. Consequently, we obtain the following passive sentence:³⁸

(74) That Sue would arrive late was expected.

(Pesetsky and Torrego (2001: 356))

Therefore, we can conclude that the structure (68) is not superior to the structure (67), and that there is no problem in assuming that the structure of passives is (67).

2.6. Further Issues

In this section, I argue for the possibility that the transitive light verb v^* is divided into two types. At the same time, I focus on the structural position of *be* and *have* as in the following examples:

- (75) a. John was not killed (by Mary).
 b. John must not be killed (by Mary).

³⁸ Koji Fujita (personal communication) points out to me that this analysis can also be applied to the following active-passive pair:

- (i) a. We took (it) for granted that he would pass the exam.
 b. It was taken for granted that he would pass the exam.

- (76) a. John had them paint his house.
 b. John had his house painted (by them).

Typically, English passive sentences employ *be*, as in (75). (75a) shows that *be* in passives overtly raises to T, but if a modal auxiliary appears, it seems to stay in situ, as in (75b). In addition, *his house* in (76a) can be passivized within the complement domain of *have*, as in (76b). Note that *be* does not appear in such a case. As we will see below, I suggest that these phenomena are closely related to lexical properties.

2.6.1. Three Types of Light Verb

I have proposed that the difference between actives and passives depends on what the transitive light verb v^* selects as its complement, as in (30), which I repeat in (77).

- (77) a. v^* merges DP iff v^* selects $-\emptyset$.
 b. v^* merges IMP and is assigned an EPP-feature iff v^* selects *-en*.

However, it is still a mystery why v^* may select either $-\emptyset$ or *-en*, whereas v selects only $-\emptyset$, as I have proposed in (43). Thus, let us assume that the transitive light verb v^* is divided into two types: v^*_a and v^*_p . Both transitive light verbs basically share the same property, that is, the assignment of an accusative Case value and an external θ -role. They differ in that the former selects $-\emptyset$ and merges DP as its specifier, while the latter selects *-en*, merges IMP, and is assigned an EPP-feature. Consequently, we have three types of light verb, v , v^*_a , and v^*_p . The

complement and the specifier of these light verbs are as follows:

(78)

	complement	specifier
v^*_a	-Ø	DP
v^*_p	-en	IMP
v	-Ø	/

2.6.2. The Difference between English Passives and Japanese Passives

The question of why English passive sentences need *be* but Japanese ones do not is a controversial one. Hasegawa (1990) answers it by assuming English passive predicates are adjectival while Japanese ones are verbal. She proposes that the structure of English passives and that of Japanese passives are as follows:³⁹

(79) The Structure of English Passives

- a. The child was scolded by the teacher.
- b. $[_{IP} \text{the child}_j [_{I'} \text{was} [_{AP} t_j [_A \text{scold}_i\text{-en}] [_{VP} (\text{by}) \text{the teacher } t_i t_j]]]]]$

(80) The Structure of Japanese Passives

- a. Kodomo-ga sensei-ni sikar-are-ta.
child-Nom teacher-by scold-Pass-Past
'The child was scolded by the teacher.'
- b. $[_{IP} \text{kodomo}_j\text{-ga} [_{I'} [_{VP1} t_j [_{VP2} \text{sensei-ni } t_j t_i] \text{sikar}_i\text{-are}] \text{-ta}]]]$

According to her analysis, since English passive predicates are adjectival,

³⁹ Hasegawa (1990) does not distinguish the *niyotte* passive and the *ni* direct passive.

they cannot form a sentence for themselves. This is why English passive sentences generally require *be*.

Indeed, some passive predicates behave as an adjective in English, but not all do so. Consider following examples:

- (81) a. a [_A broken] radio
b. A cup was broken.
- (82) a. *the [_A fed (to the baby)] peas
b. Peas were fed to the baby.
- (83) a. *the [_A sat-on] chair
b. The chair was sat on.

(modified from Carrier and Randall (1992: 192–194))

Although only (81a) is an example of an adjectival passive, if all English passive predicates behave as an adjective as Hasegawa claims, it is a mystery why (82a) and (83a) are impossible. Furthermore, not all passive predicates in English can be modified by the adverb *very*, as illustrated below.

- (84) a. They were very impressed.
b. *They were very killed.

Therefore, it seems untenable to treat English passive predicates as adjectives, and we must find another way to explain the difference between English and Japanese passives.

To solve this problem, let us assume that T in Japanese can select all the light verbs in (78), but that T in English cannot select v^*_pP . Chomsky (2001) claims that parametric variation across languages is restricted to the lexicon. Thus, whether the passive needs to accompany

be depends on the lexical property of T in the language.

Since T in English does not select v^*_pP , I suggest that v^*_pP in English needs to be selected by the unaccusative verb *be*. This can easily explain why *be* typically appears in English passive sentences.

To sum up, I propose that the structure of English passives is as follows:⁴⁰

(85) a. Mary was killed (by John).

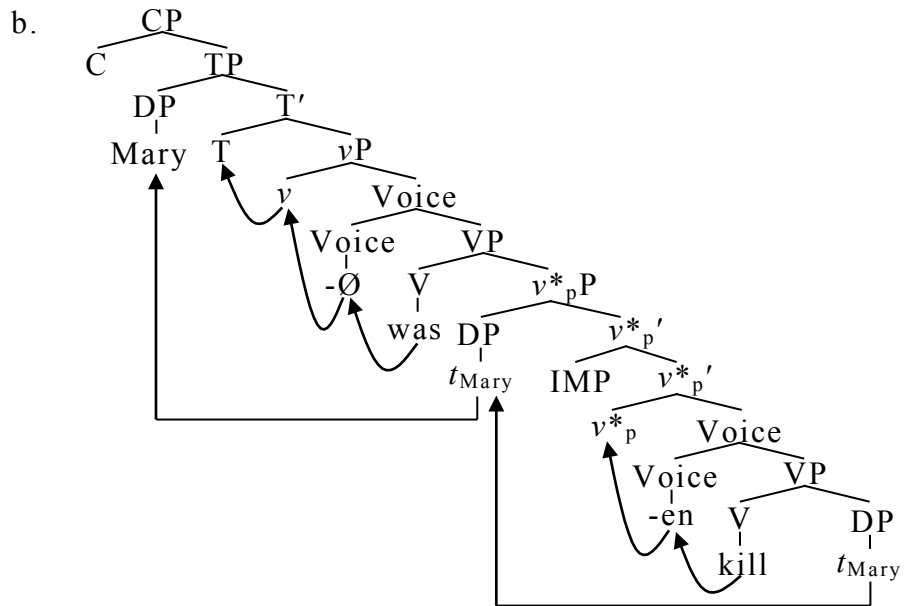

According to Lasnik (1999b), T (in his system, Infl) in (85) has a strong feature, and *be* is raised to T. On the other hand, if a modal auxiliary appears, as in (75b), *be* is raised to *v* via Voice but not raised to T. This is because T's strong feature is checked or deleted by the modal auxiliary.⁴¹

In contrast, T in Japanese can select v^*_pP , and the structure of

⁴⁰ Here I adopt Lasnik's (1999b) proposal that *be* is fully inflected in the lexicon.

⁴¹ For V-to-T raising and verbal morphology, see Lasnik (1999b) and Bobaljik (1994).

Japanese passives corresponds to (86).

- (86) a. Hanako-ga Ken-niyotte koros-are-ta.
 Hanako-Nom Ken-by kill-Pass-Past
 ‘Hanako was killed by Ken.’

b.

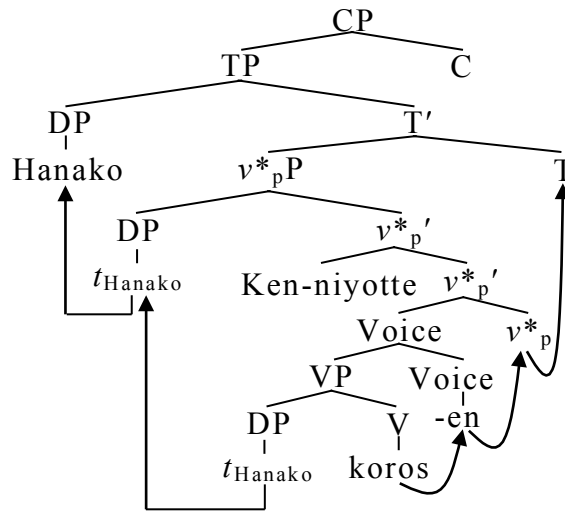

Therefore, the difference between English passives and Japanese passives arises from the lexical property of T in each language.

2.6.3. The *have* Passive

As we have seen in the previous section, v^*_pP is selected by *be* in English. Since the following sentence is ungrammatical, it seems natural to assume that *be* cannot select v^*_aP as its complement:

- (87) *John was kill Mary.

(Intended meaning: ‘John killed Mary.’)

On the other hand, both v^*_aP and v^*_pP seem to be selected by *have*, as in (88) (= (76)).

- (88) a. John had them paint his house.
 b. John had his house painted by them.

I propose that *have* in (88) is a transitive verb, and that *them* in (88a) and *his house* in (88b) are assigned an accusative Case value. I call sentences like (88b) “*have* passives.”

Recall that a transitive verb is a verb that is selected by the transitive light verb v^* (or, in the present framework, v^*_a or v^*_p), and that v^* assigns an external θ -role as well as an accusative Case value. Accordingly, *John* in (88) must be assigned an external θ -role. It has been observed that this external θ -role is Causer or Experiencer. Ritter and Rosen (1993) argue that the interpretation of *have*'s argument as Causer or Experiencer comes from the role it plays in the event, and that any ambiguity can be resolved through context and knowledge of the world. Accordingly, the external argument of *have* is Causer or Experiencer and should not be inanimate, as illustrated below.

(89) *The confusion had Mary leave in a hurry. (Givón (1975: 75))

Furthermore, we can find some differences between *have* and *make* as follows:

(90) a. *John had it seem likely that Bill had lied.

b. John made it seem likely that Bill had lied.

(91) a. *The minister of finance had there be major cuts in the military budget.

b. The minister of finance made there be major cuts in the military budget.

(Ritter and Rosen (1993: 541–542))

Make may take an expletive subject in the complement clause, but *have* may not. It has been assumed that expletives may appear only in

non-thematic positions. Consequently, Ritter and Rosen (1993) claims that *make* selects IP as its complement while *have* takes a bare VP complement. They propose the following structures:

(92) ... [_{v'} make [_{IP} Subj [_{I'} I ...

(93) ... [_{v'} have [_{VP} Subj [_{v'} V ...

Following their analysis, I assume that *have* takes either v^*_aP or v^*_pP as its complement, and I propose (94) as the structure of (88a) and (95) as the structure of (88b).

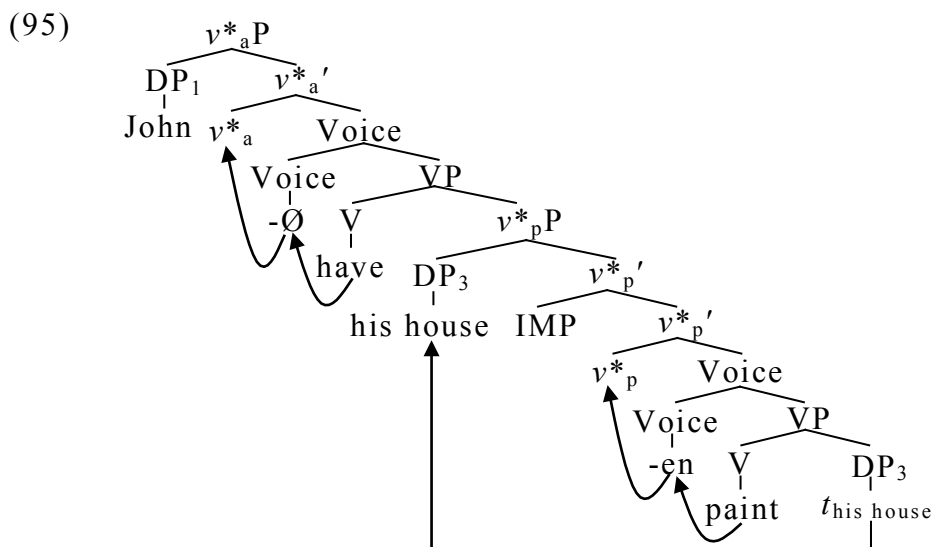
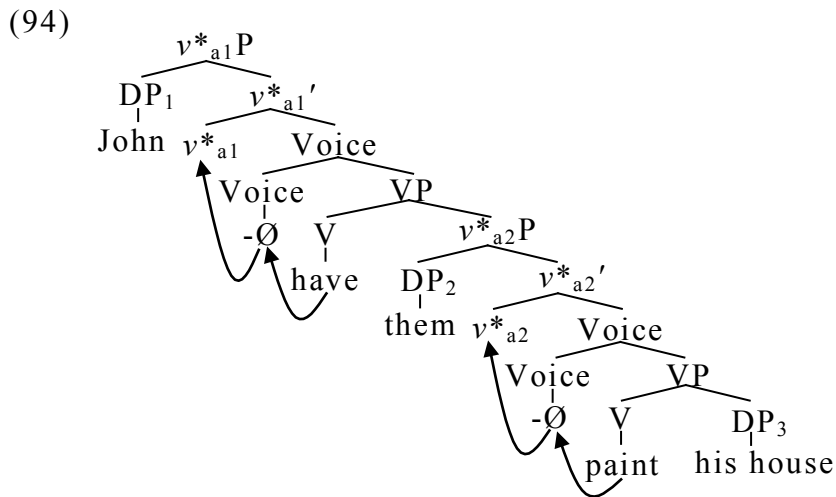

In (94), *have* selects v^*_a2P . *them* is assigned an accusative Case value

by v^*_{a1} , and v^*_{a1} projects the external argument *John*. On the other hand, *have* in (95) selects v^*_pP , and *his house* is raised from the base position to SPEC- v^*_p by the EPP-feature of v^*_p . Next, *his house* is assigned an accusative Case value by v^*_a , and v^*_a projects the external argument *John*.

To summarize this section, whether the passive requires *be* or not depends on the lexical property of T. In addition, v^*_pP can be selected not only by *be* but also by *have*. If it is selected by *have*, an additional external argument, i.e. Experiencer/Causer, is projected, since *have* is a transitive verb. Accordingly, the difference between the *have* passive and the *be* passive is the existence of an Experiencer/Causer argument.

2.7. Conclusion

In this chapter, I have demonstrated that the structure of passives is different from that of unaccusatives. In the literature, it has been assumed that these two constructions have the same structure because there is no overt external argument and no accusative Case assignment in either construction. I have proven that this assumption is not empirically correct by demonstrating that there is an implicit external argument in passives and that an accusative Case value is assigned in some passive sentences. These phenomena cannot be explained without assuming the transitive light verb v^* in the derivation of passives.

Following Multiple Agree and the Principle of Simultaneity presented by Hiraiwa (2005), I have proposed that an internal argument in the passive agrees simultaneously with both the Agree feature and the

EPP-feature of v^* . With this proposal, the internal argument can be raised to SPEC-T without violating the PIC. By assuming v^* in the structure of passives, I have suggested that the internal argument is assigned an accusative Case value through agreement with v^* in some Ukrainian passives, while it is not assigned any Case value through this agreement in passives in the other languages. In addition, if there is another internal argument, it can be assigned the same Case value as its active counterpart.

Furthermore, dividing the transitive light verb into two types makes it possible to account for why the passive typically requires *be* in English but not in Japanese. We have also observed that passivization occurs within the complement domain of *have*. In such a sentence, the external θ -role Experiencer/Causer is assigned to the external argument of *have*, and an accusative Case value is assigned to the internal argument that is raised to SPEC- v^*_p in the complement domain of *have*.

I have presented some evidence of accusative Case assignment in passives and have accounted for those phenomena under the Minimalist Program framework by proposing the structure (67).

Appendix to Chapter 2: A Recent Approach to the Passive

In this appendix, I discuss a recent account of passive constructions.

Collins (2005) also claims that the external argument is projected in the passive. He proposes that *by*-phrases are External-Merged at the specifier of the transitive light verb. In addition, he assumes XP

movement of the participle phrase in order to explain why the word order in (96a) is incorrect.

- (96) a. *The book was by John written.
 b. The book was written by John. (Collins (2005: 85))

Before the XP movement occurs, the *by*-phrase precedes the participle phrase. Then, the participle phrase is raised to the higher position, and the sentence in (96a) is derived.

Collins proposes that the structure for (96b) is as follows:

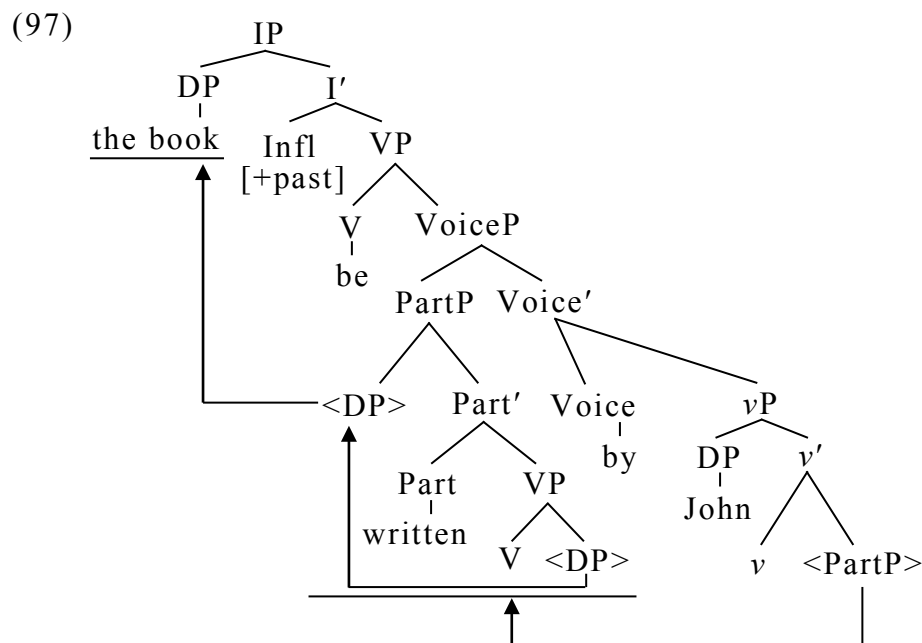

In (97), V raises to Part, and PartP raises to SPEC-Voice. Collins also assumes VoiceP, although its property is different from our VoiceP: In his proposal, *v*P is a complement of Voice, but VoiceP is a complement of *v** in our proposal. Moreover, he assumes *by* as the head of VoiceP. By assuming this, he explains why the *by*-phrase is restricted to the external argument. Since *by* is the head of VoiceP, sentences like the following are not possible.

(98) *John was written by the book.

‘The book was written by John.’ (Collins (2005: 93))

Furthermore, he claims that in passives without *by*-phrases, the head of VoiceP and the external argument are phonetically null elements. This is reminiscent of the null Comp in infinitival clauses with a PRO subject.

(99) a. For John to win would be exciting.

b. PRO to win would be exciting. (ibid.: 103)

If the Comp is the prepositional complementizer *for*, the subject of an infinitival clause is an overt lexical subject. If the Comp is a phonetically null element, the subject is PRO. In the same way, passives where the head of VoiceP is *by* have an overt external argument, but passives where the head of VoiceP is a phonetically null element have no overt external argument.

Collins’s analysis, however, has an empirical problem. As we have observed above, there are some passive sentences where accusative Case appears, and his analysis cannot explain this fact. In (97), the complement of *v*, i.e. PartP, is raised to SPEC-VoiceP, and internal arguments thus cannot agree with *v*. As we have seen in the passive of the DOC in some dialects of English, the internal argument that is not raised to the subject position is assigned structural accusative Case, and this fact contradicts his proposal. If internal arguments can agree with *v* before PartP is raised to SPEC-Voice, then the internal argument that is raised to the subject position cannot agree with Infl. Accordingly, if the analysis that accusative Case is assigned in the passive is correct, the

structure in (97) is untenable.

CHAPTER THREE

ON THE PASSIVIZABILITY OF IDIOMS IN ENGLISH AND JAPANESE¹

3.1. Introduction

Idioms have been used as a diagnostic to prove that movement operations exist in human languages. Chomsky (1980) mentions that such idiomatic expressions as in (1a) can undergo movement rules, giving (1b) or (1c).

- (1) a. John took care of Bill.
b. Care was taken of Bill.
c. Care seems to have been taken of Bill.

The idiom chunk *care* can appear separately from the other idiom chunks, and it is assumed that *care* is moved from the complement position of *take*. Given that (1b) and (1c) are grammatical and have the same interpretation as (1a), we can argue that the passivization involves a movement operation where a complement of a verb is raised to the subject position. Subject positions of passive sentences are therefore non- θ positions, which also indicates that passivization is not a lexical operation but a syntactic one. These arguments are also supported by

¹ This chapter is a revised and extended version of the paper presented at 27th National Conference of the English Linguistic Society of Japan, held at Osaka University in November 2009 and which subsequently was published as Honda (2010a). I would like to thank Koji Fujita, Yukio Oba and Sadayuki Okada for their invaluable comments and suggestions. All remaining errors and inadequacies are of course my own.

the fact that idiom chunks cannot be subjects of *tough* sentences, as shown in (2b).

- (2) a. Tabs were kept on Mary.
b. *Tabs were easy to keep on Mary.

(Lasnik and Fiengo (1974: 541))

This is because the subject position of a *tough* sentence is a θ position and an idiom chunk is never generated separately from the rest of the idiomatic expression. Thus, if an idiom chunk appears separately, there is a movement of the idiom chunk in the sentence. For this reason, we use idioms to prove that there is a movement in the passive.

Hoshi (1991) distinguishes *niyotte* passives from *ni* direct passives in Japanese by using this kind of diagnostics.² As we have already seen in chapter 2, Hoshi argues that the *niyotte* passive is the Japanese counterpart of the English *be* passive. He proves this by pointing out the fact that passivization of idiom chunks is only possible in *niyotte* passives, as illustrated in (3).

- (3) a. *Chuui-ga John-ni haraw-are-ta.
heed-Nom John-by pay-Pass-Past
'Heed_i was affected by John's paying it_i.'
<*ni* direct passive>

² For more discussion on the differences between *niyotte* passives and *ni* direct passives, see Hoshi (1991, 1999).

- b. Chuui-ga John-ni yotte haraw-are-ta.
 heed-Nom John-to due pay-Pass-Past
 ‘Heed was paid by John.’ <*niyotte* passive>
 (Hoshi (1991:70–71))

According to his analysis, this is because the subject position of *ni* direct passives is a θ position, while that of *niyotte* passives is a non- θ position. He argues that the subjects of *ni* direct passives are base-generated, whereas those of *niyotte* passives are raised from the complement position of verbs.

Therefore, it seems that there is a movement in *niyotte* passive sentences, and that the syntactic derivation of *niyotte* passives in Japanese is the same as that of *be* passives in English.

Mihara and Hiraiwa (2006: 140), however, cast doubt on Hoshi’s analysis. They argue that it is doubtful whether *chuui* ‘heed’ in (3) is really an idiom chunk because it allows modification by *zyuubunna* ‘enough’, as shown in (4).

- (4) [Zyuubunna chuui]-ga syusaisya-niyotte
 [enough heed]-Nom promoter-by
 haraw-are-nakat-ta.
 pay-Pass-Neg-Past
 ‘Enough heed was not paid by the promoter.’

Moreover, they propose that “true” idiom chunks cannot be passivized in Japanese by demonstrating the active-passive pair of the true VP idiom *X-ni goma-o sur(u)* ‘flatter X’, as shown in (5).

- (5) a. Taroo-ga sensei-ni goma-o
 Taro-Nom teacher-Dat sesame-Acc
 sur-ta. (sur-ta → sutta)
 grind-Past
 ‘Taro flattered the teacher.’ <active>
- b. *Goma-ga Taroo-niyotte sensei-ni sur-are-ta.
 sesame-Nom Taro-by teacher-Dat grind-Pass-Past
 (Lit.) ‘Sesame was ground to the teacher by Taro.’
 <passive>

Given this analysis, it seems impossible to passivize idiomatic arguments in Japanese. There is no evidence that *niyotte* passives correspond to *be* passives as long as Mihara and Hiraiwa’s analysis is correct.

In this chapter, however, I will prove that idiom chunks can be passivized both in English and Japanese and provide additional support for Hoshi’s claim that *niyotte* passives correspond to *be* passives. Moreover, I will show that Japanese idiom chunks can be passivized more freely than English ones, contrary to Mihara and Hiraiwa’s (2006) observation. I will also explain why some idiom chunks in Japanese have been considered unpassivable.

The rest of this chapter is organized as follows. Section 3.2 shows that there exist some unpassivable idioms not only in Japanese but also in English. Section 3.3 demonstrates that most Japanese idiom chunks can be passivized as long as a focus movement or a *wh*-movement occurs. In order to explain these phenomena, I introduce the focus-agreement parameter proposed in Miyagawa (2005, 2007, 2010) in section 3.4.

This parameter is directly related to the property of SPEC-T. In section 3.5, I consider why the passivizability of idiom chunks differs between English and Japanese, based on Miyagawa's analysis. Section 3.6 focuses on a set of examples that seem to be counterexamples to the proposal discussed in section 3.5. Section 3.7 presents the conclusion of this chapter.

3.2. Passivable and Unpassivable Idioms

As we have seen in section 3.1, some idioms can passivize in English, as previously shown in (2) and repeated as (6) below.

- (6) a. Tabs were kept on Mary.
b. *Tabs were easy to keep on Mary.

Given the different levels of acceptability for these two sentences, we can consider *tabs* in (6a) to have been raised from the complement position of *keep*. In this way, it is possible to claim that the English idiomatic expression *keep tabs on* can be passivized.

On the other hand, as Mihara and Hiraiwa (2006) argue, it seems impossible to passivize Japanese idioms such as *X-ni goma-o sur(u)* 'flatter X', *giron-ni mizu-o kaker(u)* 'put a damper on a discussion', *X-ni [sirahano-ya]-o tater(u)* 'single out X', and *abura-o ur(u)* 'loaf around' as shown in the following:

- (7) a. *Goma-ga Taroo-niyotte sensei-ni
 sesame-Nom Taro-by teacher-Dat
 sur-are-ta.
 grind-Pass-Past
 (Lit.) ‘Sesame was ground to the teacher by Taro.’
 (= (5b))
- b. *Mizu-ga Taroo-niyotte giron-ni kaker-are-ta.
 water-Nom Taro-by discussion-Dat put-Pass-Past
 (Lit.) ‘Water was put on a discussion by Taro.’
 (Mihara and Hiraiwa (2006: 140))
- c. * [Sirahano-ya]-ga Taroo-niyotte Hanako-ni
 [white-feather-arrow]-Nom Taro-by Hanako-Dat
 tater-are-ta.
 put-Pass-Past
 (Lit.) ‘An arrow with white feathers was put on Hanako
 by Taro.’
- d. *Abura-ga Taroo-niyotte ur-are-ta.
 oil-Nom Taro-by sell-Pass-Past
 (Lit.) ‘Oil was sold by Taro.’

These sentences produce only literal meanings; there are no idiomatic interpretations for them.

However, there are some idioms that are unpassivizable not only in Japanese but also in English. The following examples are well-known English idiomatic expressions that have no passive counterparts:

- (8) a. John kicked the bucket.

- b. *The bucket was kicked by John.
- (9) a. John shot the breeze.
 b. *The breeze was shot by John.
- (10) a. Hannah blew off steam.
 b. *Steam was blown off by Hannah. (Stanley (2001: 64))

Considering these facts, it seems that there are at least two kinds of idioms, one of which is passivizable and the other is unpassivizable. Let us call the former “Type I idiom” and the latter “Type II idiom.”

3.2.1. Type I Idioms

As I mentioned above, Type I idioms can passivize. In English, idioms such as *take advantage of NP*, *keep tabs on NP*, etc., belong to this type. In this subsection, I will present some properties shared by Type I idioms.

First, modifiers can appear in this type of idiom. It is possible to put a modifier before the idiom chunk, as follows:

- (11) Full advantage is taken of facilities nearby.
 (Nunberg et al. (1994: 521))

The following sentence shown in (12), which is taken up by Mihara and Hiraiwa against Hoshi’s claim, has almost the same structure as (11) in that the subjects are idiom chunks with modifiers.

- (12) [Zyuubunna chuui]-ga syusaisya-niyotte
 [enough heed]-Nom promoter-by
 haraw-are-nakat-ta.
 pay-Pass-Neg-Past

‘Enough heed was not paid by the promoter.’ (= (4))

According to Mihara and Hiraiwa’s argument that true idiom chunks cannot be modified, the idiom *take advantage of NP* would be counted as a non-idiomatic expression. Yet this argument does not explain why *advantage* in *take advantage of NP* can be the subject of the passive but not the subject of a *tough* sentence, as in (13).

- (13) a. Advantage was taken of Mary.
 b. *Advantage was easy to take of Bill.

(Lasnik and Fiengo (1974: 541))

Therefore, as long as the expression *take advantage of NP* is an idiom, *chuui-o hara(u)* ‘pay heed’ is also an idiomatic expression and thus, an example of a Type I idiom in Japanese. In this respect, Hoshi’s analysis is on the right track and supports the argument that the derivation of *niyotte* passives in Japanese is similar to that of *be* passives in English.

Second, the interpretation of a sentence that contains a Type I idiom is unambiguous. As we will see below, Type II idioms have both idiomatic and literal interpretations. In contrast, Type I idioms have only idiomatic readings.³

³ Chomsky (1980: 150) mentions the following: “For example, ‘John kicked the bucket’ can mean either that John hit the bucket with his foot or that he died. And ‘John took advantage of Bill,’ while it has no literal reading, has

As a result, the complement of the verb in a Type I idiom is assigned only one θ role, whereas at least two kinds of θ roles can be assigned to the complement of the verb in a Type II idiom, depending on whether the sentence has a literal interpretation or an idiomatic interpretation.

Chomsky (1981: 37) assumes a special θ role for idiomatic arguments. He calls the θ role of *advantage* in *take advantage NP* “#.” This θ role is for so-called *quasi-arguments*. Accordingly, the complement of the verb in a Type II idiom can be assigned either # or a regular θ role, such as Patient.⁴ In contrast, the complement of the verb in a Type I idiom is always assigned #.

Idioms are generally considered to be noncompositional. According to Nunberg et al. (1994), parts of Type I idioms, however, can function as antecedents for pronouns.

- (14) a. We thought tabs were being kept on us, but they weren't.
(Nunberg et al. (1994: 502))
- b. Care was taken of the infants, but it was insufficient.
(Chomsky (1981: 327))

In addition, the number of the pronoun must be identical with that of the antecedent.

- (15) a. They claimed full advantage_i had been taken of the situation, but it_i wasn't.
- b. *They claimed full advantage_i had been taken of the

essentially the same syntactic structure as ‘John took food from Bill,’ namely: NP-V-NP-PP, with further labeled bracketing.”

⁴ In the following section, I will assume that the complement of the verb in a Type II idiom is assigned not # but another special θ role.

situation, but they_i weren't.

(Nunberg et al. (1994: 506–507))

Based on these facts, Nunberg et al. suggest that Type I idioms are not noncompositional since parts of Type I idioms carry parts of their idiomatic meanings. For example, *take* in *take advantage of NP* is assigned a meaning roughly paraphrasable as ‘derive’, and *advantage* means something like ‘benefit’. This analysis can also be applied in Japanese. The word *chuu* in the idiom *chuu-o hara(u)* has the meaning ‘heed’.

One might claim that it is wrong to consider Type I idioms as true idioms in the first place since they are not noncompositional. Yet these expressions cannot appear in *tough* sentences or *ni* direct passive sentences, and thus there is no doubt that they are idioms.

3.2.2. Type II Idioms

Type II idioms are idioms that cannot passivize. In English, *kick the bucket*, *shoot the breeze*, and *blow off steam* are examples of Type II idioms. In Japanese, *X-ni goma-o sur(u)*, *giron-ni mizu-o kaker(u)*, *X-ni [sirahano-ya]-o tater(u)*, and *abura-o ur(u)* belong to this category of idioms.

What is particular about Type II idioms is that they have a literal reading in addition to an idiomatic reading. Sentence (16) presents a Japanese example and has two interpretations shown in (17a, b). Sentence (18) presents an English example and has two interpretations

shown in (19a, b).⁵

(16) Taro-ga (Yamada sensei-ni) goma-o
Taro-Nom (Professor Yamada-Dat) sesame-Acc
sur-ta. (sur-ta → sutta)
grind-Past

(17) a. Taro flattered Professor Yamada.
b. Taro ground sesame (to Professor Yamada).

(18) John kicked the bucket.

(19) a. John died.
b. John hit the bucket with his foot.

(17a) and (19a) are idiomatic readings of (16) and (18), and (17b) and (19b) are literal readings of (16) and (18), respectively. Since (16) and (18) both have two readings, there must be two base structures to derive these sentences.

If (16) or (18) is changed to the passive, they no longer have idiomatic readings, and only the literal readings are possible. This observation means that passivization only works with the derivation that produces a literal reading, which is a simple transitive sentence, and that Type II idioms *per se* cannot passivize.

It is possible to raise two questions here. First, why is it impossible to passivize Type II idioms? Given that passivization is simply a syntactic operation, it is unclear why the operation cannot apply to Type II idioms, since there are no syntactic differences between Type I and Type II idioms. I will answer this question in section 3.5.

⁵ It is easier to get the literal reading in (16) if we omit the dative argument.

Second, are there alternate ways to passivize Type II idioms? As we will see below, there are some cases where Type II idioms can passivize in Japanese.

3.3. Some Cases Where Type II Idioms Can Passivize

We have observed that Type II idioms cannot passivize. More precisely, sentences containing a Type II idiom do not have idiomatic readings in the passive.

However, if a phrase other than the idiom moves to the sentence-initial position, passive sentences containing a Type II idiom do have idiomatic readings. Consider the following examples:⁶

⁶ Harada (1977) also points out that the idiom *[sirahano-ya]-o tater(u)* can passivize. He presents sentences where a phrase other than the idiom is raised to the sentence-initial position, as illustrated below:

- (i) Kare-ni [sirahano-ya]-ga tater-are-ta.
 him-Dat [white-feather-arrow]-Nom put-Pass-Past
 ‘He was singled out.’ (Harada (1977: 93))

He also takes up other idioms like *keri-o taker(u)* ‘bring ... to an end’, *keti-o taker(u)* ‘criticize’, and *saba-o yom(u)* ‘cheat in counting’, but, in these sentences, what is raised to the sentence-initial position is a phrase other than the idiom chunk.

- (ii) a. [[Kono-mondai]-ni]-wa korede keru-ga
 [[this problem]-Dat]-Top at this point end-Nom
 taker-are-ta.
 attach-Pass-Past
 ‘This problem was brought to an end at this point.’
 b. [[Kono-bunkseki]-ni]-wa keti-ga taker-are-ta.
 [[this analysis]-Dat]-Top meanness-Nom attach-Pass-Past
 ‘This analysis was criticized.’
 c. [[Kono-tookei]-ni]-wa daibu saba-ga
 [[this statistics]-Dat]-Top quite mackerel-Nom

- (20) a. ?Yamada sensei-ni-mo, goma-ga
 Professor Yamada-Dat-also sesame-Nom
 Taroo-niyotte sur-are-ta.
 Taro-by grind-Pass-Past
 ‘Professor Yamada is one of the people who Taro flattered.’
- b. ?[Hanako-no-giron]-ni-mo, mizu-ga
 [Hanako-Gen-discussion]-Dat-also water-Nom
 Taroo-niyotte kaker-are-ta.
 Taro-by put-Pass-Past
 ‘Hanako’s discussion is one of the things that Taro put a damper on.’
- c. ?Hanako-ni-mo, [sirahano-ya]-ga
 Hanako-Dat-also [white-feather-arrow]-Nom
 Taroo-niyotte tater-are-ta.
 Taro-by put-Pass-Past
 ‘Hanako is one of the people who Taro singled out.’

Although the sentences in (20) are a little bit awkward, if a phrase with the particle “*mo*” moves to the sentence-initial position, the sentence has an idiomatic interpretation in addition to a literal interpretation.⁷

yom-are-tei-ru.

read-Pass-Progress-Pres

‘This statistics is quite cheated in counting.’ (Harada (1977: 93))

⁷ Although all the informants judged (20) and (21) to be awkward, they also interpreted idiomatic readings for (20) and (21) whereas they only got literal readings in (7). The awkwardness in (20) and (21) may stem from a functional reason, but I leave this issue for future research. What is

Moreover, the movement of a *wh*-phrase to the sentence-initial position also makes it possible to get an idiomatic reading.

- (21) a. ?[Dono sensei]-ni goma-ga Taroo-niyotte
 [which teacher]-Dat sesame-Nom Taro-by
 sur-are-ta no?
 grind-Pass-Past Q
 ‘Which teacher did Taro flatter?’
- b. ?[Dono giron]-ni mizu-ga Taroo-niyotte
 [which discussion]-Dat water-Nom Taro-by
 kaker-are-ta no?
 put-Pass-Past Q
 ‘Which discussion did Taro put a damper on?’
- c. ?Dare-ni [sirahano-ya]-ga Taroo-niyotte
 who-Dat [white-feather-arrow]-Nom Taro-by
 tater-are-ta no?
 put-Pass-Past Q
 ‘Who did Taro single out?’

Yet, these idioms cannot appear in *ni* direct passive sentences, as shown in (22).

- (22) a. *Yamada sensei-ni-mo, goma-ga
 Professor Yamada-Dat-also sesame-Nom
 Taroo-ni sur-are-ta.
 Taro-by grind-Pass-Past

important here is whether the idiomatic interpretation is possible in the passive sentences.

- b. *[Hanako-no giron]-ni-mo, mizu-ga
 [Hanako-Gen discussion]-Dat-also water-Nom
 Taroo-ni kaker-are-ta.
 Taro-by put-Pass-Past
- c. *Hanako-ni-mo, [sirahano-ya]-ga
 Hanako-Dat-also [white-feather-arrow]-Nom
 Taroo-ni tater-are-ta.
 Taro-by put-Pass-Past
- (23) a. *[Dono sensei]-ni goma-ga Taroo-ni
 [which professor]-Dat sesame-Nom Taro-by
 sur-are-ta no?
 grind-Pass-Past Q
- b. *[Dono giron]-ni mizu-ga Taroo-ni
 [which discussion]-Dat water-Nom Taro-by
 kaker-are-ta no?
 put-Pass-Past Q
- c. *Dare-ni [sirahano-ya]-ga Taroo-ni
 who-Dat [white-feather-arrow]-Nom Taro-by
 tater-are-ta no?
 put-Pass-Past Q

These idioms can appear only in *niyotte* passives, suggesting that Type II idioms can passivize in Japanese. On the other hand, Type II idioms cannot passivize in English. Contrary to Mihara and Hiraiwa's (2006) observation that Japanese idioms are unable to passivize, Japanese idioms can passivize more freely than English idioms. The

next question that emerges is why the movement of phrases other than the idiom chunks makes it possible to passivize Type II idioms.

3.4. The Focus-Agreement Parameter and the EPP on T

In order to answer the question above, I introduce the focus-agreement parameter proposed in Miyagawa (2005, 2007, 2010).

Miyagawa proposes that a language is either agreement-prominent or focus-prominent, and that the EPP-feature on T interacts with either the ϕ -probe, which corresponds to the uninterpretable ϕ -feature, or the topic/focus feature.⁸ According to his analysis, both the ϕ -probe and the topic/focus feature are postulated at C instead of T. English is an agreement-prominent language and the ϕ -probe on C percolates down from C to T, as shown in (24).

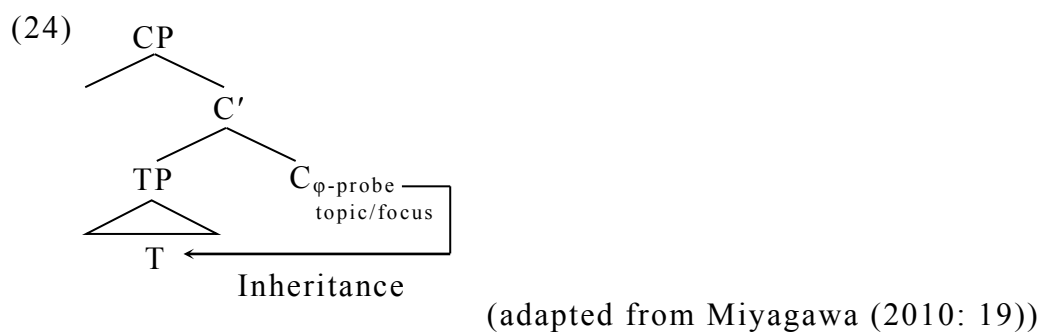

Thus, what agrees with the ϕ -probe, namely the nominative subject, is always raised to SPEC-T due to the EPP-feature on T, which interacts with the ϕ -probe.

Japanese is a focus-prominent language and the topic/focus feature percolates down to T, as shown in (25).

⁸ Note that the focus here refers not to “informational focus” but to “identificational focus” in É. Kiss’s (1998) dichotomy.

(25)

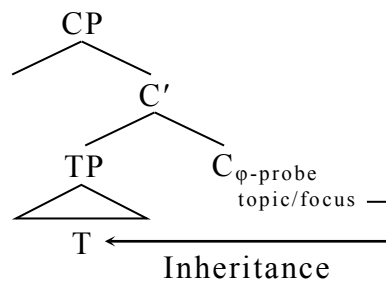

(Miyagawa (2010: 19))

Thus, what agrees with the topic/focus feature is always raised to SPEC-T due to the EPP-feature, which means that the nominative subject is not necessarily raised to SPEC-T in Japanese.

3.4.1. A-Movement in Japanese

Miyagawa presents the following examples to show that phrases other than nominative subjects are raised to SPEC-T in Japanese:

(26) *Taroo-ga zen'in-o sikar-anakat-ta.*

Taro-Nom all-Acc scold-Neg-Past

'Taro didn't scold all.'

not > all (all > not)

(27) *Zen'in-ga siken-o uke-nakat-ta.*

all-Nom test-Acc take-Neg-Past

'All did not take the test.'

*not > all, all > not

(28) *Siken-o_i zen'in-ga t_i uke-nakat-ta.*

test-Acc all-Nom take-Neg-Past

'All didn't take the test.'

not > all, all > not

(ibid.: 74–75)

As illustrated in (26), the Japanese universal quantifier *zen'in* 'all' may

be interpreted as the partial negation ‘not all’.⁹ This is because ‘all’ is inside the c-command domain of negation.

In contrast, when the universal quantifier is in the subject position, it is interpreted outside the scope of negation. In this way, partial negation is impossible because negation does not c-command the subject position. Miyagawa assumes that the structure of (27) is (29).

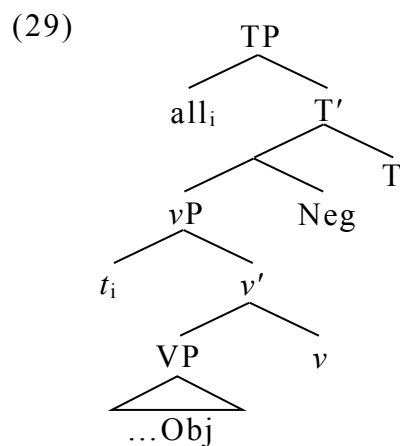

(Miyagawa (2010: 75))

However, when the object is raised to the sentence-initial position, as in (28), the subject, which is the universal quantifier, is interpreted inside the scope of negation, and partial negation becomes possible. Miyagawa suggests that the object is raised to SPEC-T by scrambling, and that the subject ‘all’ stays in situ at SPEC-*v*, as shown in (30).¹⁰

⁹ According to Miyagawa (2010), the reading, ‘all > not’, is due to a collective reading of ‘all’.

¹⁰ Following the requirements imposed by the notion of phases, Miyagawa assumes that the object must first move and adjoin to *vP* before it moves to SPEC-T in (30).

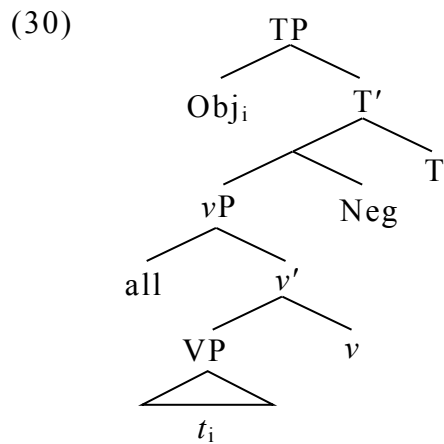

(Miyagawa (2010: 76))

Thus, the subject ‘all’ is c-commanded by negation, and partial negation becomes possible. What is important here is that phrases other than the nominative subject can move to SPEC-T in Japanese.

3.4.2. Topic and Focus

Japanese is a focus-prominent language, in which topic or focus phrases agree with T. According to Miyagawa (2010), what is inherited from C to T is the feature “–focus”, as shown in (31).

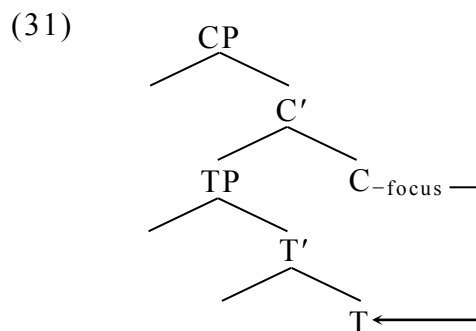

(ibid.: 87)

Miyagawa’s assumption about the topic/focus feature is as follows:

(32) The default feature for topic/focus is –focus (topic).

(ibid.: 86)

In other words, the feature –focus is the topic feature, which requires that something should move to SPEC-T if focused phrases do not appear.

What is then raised to SPEC-T is interpreted as topic. There is no agreement if focused phrases do not appear and the feature $-focus$, which is inherited by T, simply requires that something should fill SPEC-T, as illustrated in (33).

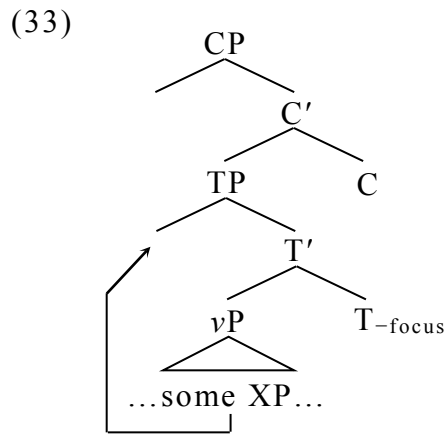

(Miyagawa (2010: 88))

In contrast, if a focused phrase, which has the feature $+focus$, appears, it agrees with $-focus$ at C, and this $-focus$ is valued as $+focus$ by the goal, i.e. the focused phrase, as shown in (34).

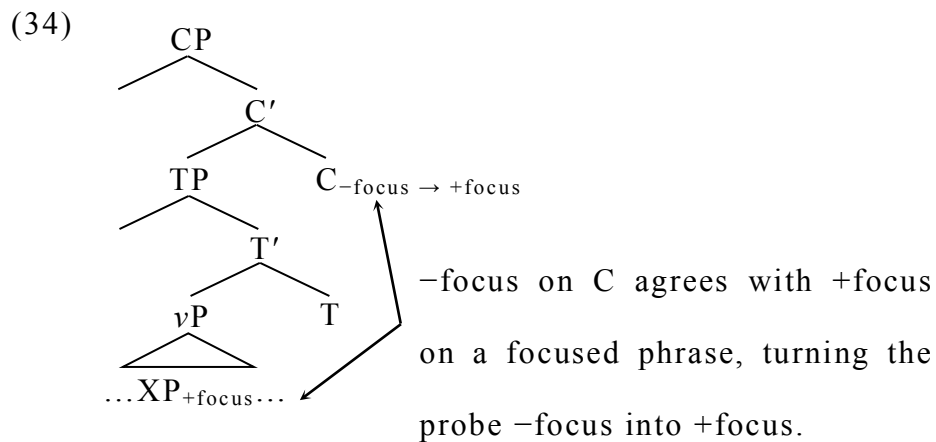

(ibid.)

Next, $+focus$ is inherited by T from C, and the phrase that has $+focus$ is raised to SPEC-T, as shown in (35).

(35)

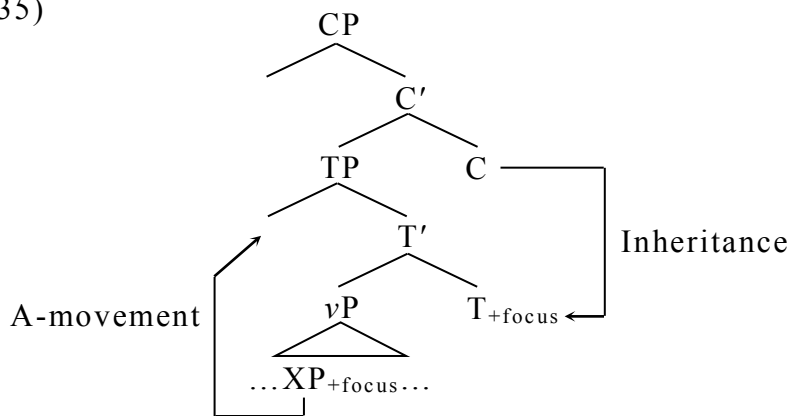

(Miyagawa (2010: 88))

To sum up, if a focused phrase appears, it is raised to SPEC-T; otherwise, something is raised to SPEC-T and it is interpreted as topic.

3.4.3. +focus in Japanese

According to Miyagawa, one example of the phrase with +focus in Japanese is the *mo* 'also' expression, and thus phrases with the particle *mo* are raised to SPEC-T. It is possible to find evidence to support this claim. First, phrases with *mo* carry focus stress, as illustrated in (36).

(36) a. Taroo-wa HON-o katta.

Taro-Top book-Acc bought

'Taro bought a book.'

b. TAROO-*mo* hon-o katta.

Taro-also book-Acc bought

'Taro also bought a book.'

(ibid.: 63)

If the sentence does not contain a *mo* expression, the sentence has neutral intonation, with the object receiving default prominence, as in (36a).

Second, the *mo* phrase is interpreted outside the scope of negation, as shown in (37a). This is because the *mo* phrase is raised to SPEC-T, as

shown in (37b).

(37) a. John-ga hon-mo kaw-anakat-ta.

John-Nom book-also buy-Neg-Past

‘A book is one of the things that John did not buy.’

(Miyagawa (2010: 64))

b. John-ga [TP hon-mo [VP t_{Subj} [VP t_{Obj} kaw-anakat-]] ta]

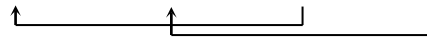

(ibid.: 68)

Third, a weak cross over violation is suppressed in (38b), and the *mo* phrase binds the reciprocal ‘each other,’ as in (39).

(38) a. ?*[Sakihodo e_i e_j yonda hito_i]-ga

[just.now read person]-Nom

futatu-izyou-no meiwaku meeru_j-o kesita.

two-more.than-Gen spam mail-Acc deleted

‘The person who read them just now deleted more than two pieces of spam mail.’

b. Futatu-izyou-no meiwaku meeru_j-mo [sakihodo e_i e_j

two-more.than-Gen spam mail-also [jut.now

yonda hito_i]-ga t_j kesita.

read person]-Nom deleted

(Lit.) ‘More than two pieces of spam mail also, the person who read them just now deleted.’

(ibid.: 66–67)

(39) Taroo-to Hanako-mo_i otagai-no

Taro-and Hanako-also each.other-Gen

sensei-ga t_i suisensita.
 teacher-Nom recommended
 (Lit.) ‘Taro and Hanako also, each other’s teachers
 recommended.’ (Miyagawa (2010: 67))

In this case, the movement of *mo* to SPEC-T is A-movement, not \bar{A} -movement.

Miyagawa assumes that *wh*-phrases also have +focus. The Q feature on the question C itself is an interpretable feature and thus unable to probe *wh*-phrases. Therefore, Miyagawa proposes that a *wh*-phrase has the focus feature, which agrees with C.

Miyagawa (2001) claims that the *wh*-feature, which corresponds to the focus feature, is on T instead of C in Japanese, and that the scrambling of a *wh*-phrase to SPEC-T counts as overt *wh*-movement. In other words, *wh*-phrases are raised not to SPEC-C but to SPEC-T in Japanese. This claim can be verified by the following examples:

- (40) a. Hanako-to_i zen’in-ga t_i asoba-nakat-ta.
 Hanako-with_i all-Nom t_i play-Neg-Past
 ‘With Hanako, all did not play.’
 *not > all, all > not
- b. Dare-to_i zen’in-ga t_i asoba-nakat-ta no?
 who-with_i all-Nom t_i play-Neg-Past Q
 ‘With whom, all didn’t play?’
 not > all, (all > not) (Miyagawa (2001: 317–318))

In (40a), the subject ‘all’ is raised to SPEC-T and only the wide-scope reading of ‘all’ relative to negation is possible. This fact shows that

PPs cannot fulfill the EPP requirement of T. However, negation can take scope over the subject ‘all’ in (40b), indicating that the *wh*-PP *dare-to* ‘who-with’ in (40b) agrees with T and is raised to SPEC-T. Specifically, the *wh*-PP in (40b), but not the “normal” PP in (40a), contains a feature that matches a feature on T, and this agreement enables the *wh*-PP to move to SPEC-T. Therefore, the *wh*-feature in Japanese is on T.

3.5. Proposal

As we have observed, Type I idioms can passivize both in English and Japanese, while Type II idioms can passivize neither in English nor in Japanese. However, if a phrase other than the idiom chunks, e.g. a *mo* phrase or a *wh*-phrase, is raised to SPEC-T, it becomes possible to passivize Type II idioms in Japanese.

Although idiom chunks like *advantage* in *take advantage of NP* are assigned the θ role #, I suggest that this θ role is assigned only in Type I idioms, not in Type II idioms. I will assume another special θ role for the complement of the verb in a Type II idiom. According to Nunberg et al. (1994), *advantage* in *take advantage of NP* means something like ‘benefit’. In this respect, the argument assigned the θ role # has some kind of interpretation but its precise meaning is deficient or vague.

In contrast, *the bucket* in *kick the bucket*, which is a Type II idiom, lacks an interpretation and does not have any meaning at all.¹¹ Given

¹¹ In contrast to Type I idioms, parts of Type II idioms cannot be antecedents for pronouns, as illustrated in the following example:

that the phrase *kick the bucket* does not exist as a phrase in the lexicon but is generated by the merging operation $V + DP = [{}_{VP} V DP]$ in narrow syntax, the DP *the bucket* must be assigned some θ role by the verb *kick*, since external merges occur due to θ roles (see Chomsky (2008)). I assume that semantically vacuous arguments are assigned an imaginary θ role, which is different from #. I call this θ role “*i*” after an imaginary number in mathematics, and *the bucket* in *kick the bucket* is assigned this θ role.

In order to explain the passivizability of idioms, let us assume the following condition:

(41) Condition on Imaginary Theta Role (CIT)

The argument that is assigned the θ -role *i* cannot be topic or focus.

According to Miyagawa (2005, 2007), the phrase at SPEC-T is interpreted as topic at the interface provided a focused phrase does not appear. This interface system would use the input from syntax, which has the structure in (42), and impose the informational structure of topic-focus.¹²

$$(42) \quad \underbrace{[{}_{TP} \dots]}_{\text{topic}} \quad \underbrace{[{}_{VP} \dots]}_{\text{focus}} \quad \quad \quad (\text{Miyagawa (2005: 214)})$$

Thus, when a focused phrase does not appear, the phrase at SPEC-T is

(i) *John kicked the bucket yesterday, and Mary kicked it the day before.
(Stanley (2001: 64))

¹² Note that “focus” in (41) is identificational focus whereas “focus” in (42) is informational focus.

automatically interpreted as topic by the interface system.¹³ Since the phrase at SPEC-T is interpreted as topic at the interface, it is natural to assume that the condition in (41) is an interface condition.

By assuming CIT in (41), we can explain why (43)(= (8b)) and (44)(= (7a)) are unacceptable.

(43) *The bucket was kicked by John.

(44) *Goma-ga Taroo-niyotte sensei-ni sur-are-ta.
 sesame-Nom Taro-by teacher-Dat grind-Pass-Past
 (Lit.) ‘Sesame was ground to the teacher by Taro.’

English is an agreement-prominent language, and the ϕ -probe is inherited by T from C. Thus, the nominative subject is necessarily raised to SPEC-T and interpreted as topic based on the structure in (42). In (43), the idiom chunk *the bucket* is at SPEC-T, resulting in a violation of CIT.

On the other hand, there are two derivations for (44). In one derivation, *goma* has +focus, which means *goma* is focused. In this case, –focus on C agrees with +focus on *goma*, and it is valued as +focus. This feature is then inherited by T, and *goma* is raised to SPEC-T. The idiom chunk *goma*, which is assigned the θ -role *i*, is focus in this derivation; hence, a violation of CIT. In the other derivation, *goma* does not have +focus and there is no focused phrase in (44). In this case, *goma* is the nearest phrase from T, and therefore it is raised to T by

¹³ As we saw in 3.4.2, Miyagawa (2010) assumes that the feature on C is –focus when C does not agree with any focused phrase, and that the only thing this feature requires is that its specifier be filled, which Miyagawa calls “pure” EPP nature of topic.

the EPP. Again, this is a violation of CIT because the idiom chunk *goma* is interpreted as topic based on (42).

Of course, if (43) and (44) do not have idiomatic readings and instead have literal readings, they are acceptable. In this case, however, the θ -role that is assigned to the complements of the verbs is Patient, not *i*. As a result, no violation of CIT is induced.

A final question remains: why are the sentences in (45a)(= (20a)) and (45b)(= (21a)) relatively acceptable?

- (45) a. ?Yamada sensei-ni-mo, goma-ga
Professor Yamada-Dat-also sesame-Nom
Taro-niyotte sur-are-ta.
Taro-by grind-Pass-Past
'Professor Yamada is one of the people who Taro
flattered.'
- b. ?[Dono sensei]-ni goma-ga
[which teacher]-Dat sesame-Nom
Taro-niyotte sur-are-ta no?
Taro-by grind-Pass-Past Q
'Which teacher did Taro flatter?'

Before answering this question, let us return to the structure of the passive that we have proposed in chapter 2. I suggest the following structure for the passive in Japanese:

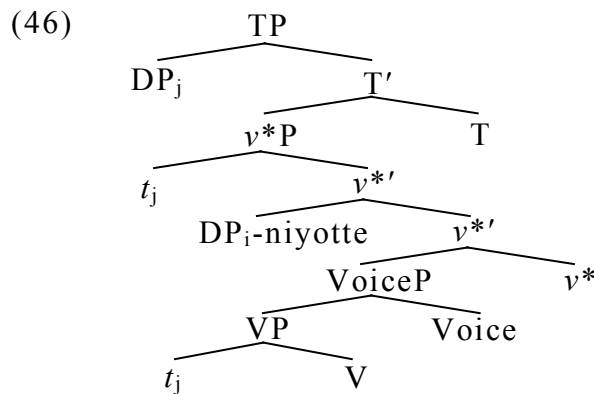

One might wonder whether the *niyotte*-phrase is a DP or a PP. Mastuoka (2001) discusses this question, pointing out the following examples:

- (47) *Taroo-wa [seikatu-sidoo-no sensei]-niyotte
 Taro-Top [discipline-supervision-Gen teacher]-by
 huta-ri sikar-are-ta.
 2-CL scold-Pass-Past
 ‘Taro was scolded by two teachers in charge of school discipline.’
 cf. Taroo-wa [huta-ri-no seikatu-sidoo-no
 Taro-Top [2-CL-Gen discipline-supervision-Gen
 sensei]-niyotte sikar-are-ta.
 teacher]-by scold-Pass-Past
 (Matsuoka (2001: 82))

In Japanese, a floated numeral quantifier (FQ) can modify an NP, and in such a case the FQ and the NP must c-command each other (Miyagawa (1989)). Accordingly, an FQ cannot modify an NP within a PP. In (47), since the FQ *huta-ri* cannot modify the NP *seikatu-sidoo-no sensei*, the *niyotte*-phrase is a PP. This explains the difference between (48a)

and (48b).

(48) a. Taroo-niyotte_i zen'in-ga *t_i* nagur-are-nakat-ta.

Taro-by all-Nom hit-Pass-Past

(Lit.) 'By Taro, all were not hit.'

*not > all, all > not

b. Dare-niyotte_i zen'in-ga *t_i* nagur-are-nakat-ta no?

whom-by all-Nom hit-Pass-Past Q

(Lit.) 'By whom, all weren't hit?'

not > all, (all > not)

Although partial negation is not possible in (48a), the universal quantifier *zen'in* is interpreted inside the scope of negation in (48b), where the *niyotte*-phrase is raised to T instead of the internal argument. This interpretation is possible because the *wh*-PP can satisfy the EPP requirement of T, as we have seen in 3.4.3. This indicates that the internal argument *zen'in* is c-commanded by negation in (48b), and it is at SPEC-*v** in (46).

Considering the discussion above, we can conclude that something other than the internal argument can be raised to SPEC-T in Japanese passive sentences. Since *mo* phrases and *wh*-PPs can be raised to SPEC-T, it is natural to assume that the idiom chunk *goma* stays at SPEC-*v** in (45). In this way, there is no violation of CIT in (45), although (45) is the passive of a Type II idiom.

Furthermore, CIT is also related to active sentences. As we have observed in 3.4.1, the accusative object can be raised to SPEC-T in Japanese. In that case, the nominative subject stays at SPEC-*v**. The

reason why (49) is unacceptable is that the idiom chunks are raised to SPEC-T, which leads to a violation of CIT.

- (49) a. *Goma-o_i Taroo-ga sensei-ni *t_i*
 Sesame-Acc Taro-Nom teacher-Dat
 sur-ta. (sur-ta → sutta)
 grind-Past
 (Lit.) ‘Sesame, Taro ground to the teacher.’
- b. *Mizu-o_i Taroo-ga giron-ni *t_i*
 Water-Acc Taro-Nom discussion-Dat
 kaker-ta. (kaker-ta → kaketa)
 put-Past
 (Lit.) ‘Water, Taro put on the discussion.’
- c. * [Sirahano-ya]-o_i Taroo-ga Hanako-ni *t_i*
 [white-feather-arrow]-Acc Taro-Nom Hanako-Dat
 tater-ta. (tater-ta → tateta)
 put-Past
 (Lit.) ‘A white feather arrow, Taro put on Hanako.’
- d. *Abura-o_i Taroo-ga *t_i* ur-ta. (ur-ta → utta)
 Oil-Acc Taro-Nom sell-Past.
 (Lit.) ‘Oil, Taro sold.’

Therefore, the reason why the passive of Type II idioms is not acceptable is not that the passivization of Type II idioms *per se* is impossible; rather the idiom chunks assigned the θ -role *i* cannot be raised to SPEC-T due to CIT. In English, the passive of a Type II idiom is always unacceptable since the nominative subject is necessarily raised

to SPEC-T. In contrast, Type II idioms can passivize in Japanese because phrases other than the nominative subject can be raised to SPEC-T.¹⁴

One might point out the following as counterexamples:

- (50) a. kosi-o_i Taroo-ga t_i orosita benti
 hip-Acc_i Taro-Nom t_i lowered bench
 ‘the bench where Taro sat down’ (Miyagawa (2007: 54))
- b. Kosi-o_i John-ga t_i orosita.
 hip-Acc_i John-Nom lowered
 ‘John sat down.’ (adapted from (Hoshi 1991: n.29))

Miyagawa (2007) uses the example in (50a) as the evidence that

¹⁴ Yukio Oba points out to me that the following example may be as acceptable as (45):

- (i)??[Goma-ga Yamada sensei-ni-mo suunin-no gakusei-niyotte
 [sesame-Nom professor Yamada-Dat-also some students-by
 sur-are-tei-ta no] -wa syuutino zizitu-da.
 grind-Pass-Perf-Past Nominalizer]-Top well-known fact-Cop
 ‘It is a well-known fact that Professor Yamada had been flattered by
 some students.’

Note that the embedded clause that contains the idiom itself is the topic of the matrix clause in (i), which indicates that the idiom chunk constitutes “a part” of the topic of the matrix clause. It seems that a sentence becomes more acceptable when the idiom chunk is a part of the topic of the matrix clause than when it is the matrix topic, as in (ii).

- (ii)*Goma-ga Yamada sensei-ni-mo suunin-no gakusei-niyotte
 sesame-Nom professor Yamada-Dat-also some students-by
 sur-are-tei-ta.
 grind-Pass-Perf-Past
 ‘Professor Yamada had been flattered by some students.’

I leave open whether the difference in acceptability between (i) and (ii) stems from a syntactic reason or some other reasons. At least, the movement of an idiom chunk to SPEC-T in a matrix clause indeed violates CIT.

A-movement scrambling can move an idiom chunk. In (50), the idiom chunk *kosi-o* in the idiom *kosi-o oros(u)* ‘sit down’ is A-moved to SPEC-T. Note that this idiom cannot passivize, as shown in (51).

(51) *Kosi-ga John-niyotte oros-are-ta.

hip-Nom John-by lower-Pass-Past.

‘His hip was lowered by John.’ (Hoshi (1991: n.29))

Since *kosi-o oros(u)* cannot passivize, this idiom seems to be a Type II idiom, while the idiom chunk can be A-moved. In this way, these examples function as counterexamples to the proposal here.

However, the idiom *kosi-o kaker(u)*, which has the same meaning as *kosi-o oros(u)*, leads to a different conclusion. A-movement scrambling cannot move *kosi-o*, as shown in (52), and the passivization of *kosi-o kaker(u)* is impossible, as shown in (53).

(52) a. *kosi-o_i Taroo-ga *t_i* kaker-ta

hip-Acc_i Taro-Nom *t_i* sit-Past

benti (kaker-ta → kaketa)

bench

b. *Kosi-o_i Taroo-ga *t_i* kaketa.

hip-Acc_i Taro-Nom *t_i* sat

(53) *Kosi-ga Taroo-niyotte kaker-are-ta.

hip-Nom Taro-by sit-Pass-Past

(Lit.) ‘His hip was sat by Taro.’

In fact, there are some differences between *kosi-o oros(u)* and *kosi-o kaker(u)*, as illustrated in the following examples:

- (54) a. *Taroo-ga kurumaisu-ni kanzya-no kosi-o kaketa.
 Taro-Nom wheelchair-on patient-Gen hip-Acc sat
- b. Taroo-ga kurumaisu-ni kanzya-no kosi-o orosita.
 Taro-Nom wheelchair-on patient-Gen hip-Acc lowered
 ‘Taro sat the patient down on the wheelchair.’

The subject may not be the inalienable possessor of *kosi* in *kosi-o oros(u)*, but the subject must be the inalienable possessor of *kosi* in *kosi-o kaker(u)*. Thus, *kosi-o oros(u)* does not have the same idiomatic nature as *kosi-o kaker(u)*, and it is questionable whether *kosi-o oros(u)* is a true idiom. Since the idiom chunk in *kosi-o kaker(u)*, which has the same meaning as *kosi-o oros(u)*, cannot be raised to SPEC-T in either the active or the passive, we can conclude that (50) and (51) are not counterexamples to our proposal.

Note that the passive of the idiom *kosi-o kaker(u)* is not acceptable even though the phrase other than the idiom chunk is raised to SPEC-T.

- (55) *[Dono benti]-ni kosi-ga Taroo-niyotte
 [which bench]-Dat hip-Nom Taro-by
 kaker-are-ta no?
 sit-Pass-Past Q
 (Intended meaning) ‘Which bench did Taro sit down on?’

We must therefore find another way to explain the unacceptability of (55), despite the fact that there is no violation of CIT. I will discuss this problem in the next section.¹⁵

¹⁵ Hoshi (1991: n.29) explains the unacceptability of (51) as follows: “I speculate that the ungrammaticality of [(51)] is due to the existence of some

3.6. Some Exceptions

3.6.1. Possessor-Raising Constructions

Japanese has a large set of idiomatic expressions containing references to parts of the human body, such as *hone-o or(u)* ‘take great pains’, *hara-o tater(u)* ‘feel irritated’, in addition to *kosi-o kaker(u)*. These idioms cannot passivize.

- (56) a. Taroo-ga sono sigoto-ni hone-o
Taro-Nom the work-Dat bone-Acc
or-ta. (or-ta → otta)
break-Past
‘Taro took great pains with the work.’
- b. *Hone-ga Taroo-niyotte sono sigoto-ni
bone-Nom Taro-by the work-Dat
or-are-ta.
break-Pass-Past
(Lit.) ‘His bone was broken with the work by Taro.’
- (57) a. Taroo-ga Hanako-ni hara-o
Taro-Nom Hanako-Dat stomach-Acc
tater-ta. (tater-ta → tateta)
stand-Past
‘Taro felt irritated with Hanako.’

condition, which states informally that an inalienably possessed NP cannot be passivized.” In the next section, I will discuss the reason why an inalienably possessed NP cannot be the subject of a passive sentence.

- b. *Hara-ga Taroo-niyotte Hanako-ni tater-are-ta.
 Hanako-Nom Taro-by Hanako-Dat stand-Pass-Past
 (Lit.) ‘His stomach was stood with Hanako by Taro.’

These idioms seem to be Type II idioms, but they are different from other Type II idioms because the passive of these idioms is unacceptable even though phrases other than the idiom chunks are raised to SPEC-T.

- (58) a. *Sono sigoto-ni-mo, hone-ga Taroo-niyotte
 the work-Dat-also bone-Nom Taro-by
 or-are-ta.
 break-Pass-Past
 (Intended meaning) ‘The work is one of the things that
 Taro took great pains with.’

- b. *Dono sigoto-ni hone-ga Taroo-niyotte
 which work bone-Nom Taro-by
 or-are-ta no?
 break-Pass-Past Q
 (Intended meaning) ‘Which work did Taro take great
 pains with?’

Thus, one might consider these examples to be counterexamples to our proposal.

Yet, there are important differences between these idioms and the Type II idioms we have discussed. In (56a) and (57a), the subjects are the inalienable possessors of the internal arguments, and their θ -roles are not Agent but Patient or Experiencer. In Japanese, this kind of expression also appears in the sentences that do not contain idiomatic

expressions, which are called “Possessor Raising Constructions (PRC).”

Hasegawa (2001, 2004) proposes that (59) has the structure in (60).

(59) Tomoko-ga kosi-o itame-ta.

Tomoko-Nom back-Acc hurt-Past

‘Tomoko_i hurt her_i back.’

(60) [IP [I' [vP [VP [VP [DP [DP Tomoko] [D' D kosi]] itame]] v] -ta]]

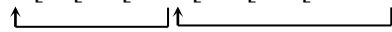

The subject *Tomoko* is base-generated as a possessor of the object *kosi* ‘back’ and undergoes Possessor Raising, which detaches the possessor from the host DP and attaches it to the maximal projection immediately above, i.e. VP. The object *kosi* is assigned accusative Case from *v*, and the raised possessor moves to SPEC-I to receive nominative Case.

Hasegawa claims that the light verb *v* in (60) assigns accusative Case but it does not project the external argument. Thus, there is no Agent in (59). Interestingly, this kind of sentence does not have the passive counterpart.

(61) *Kosi-ga Tomoko-niyotte itamer-are-ta.

back-Nom Tomoko-by hurt-Pass-Past.

(Intended meaning) ‘Tomoko hurt her back.’

In the literature (e.g. Jaeggli (1986)), it has been stated that the passive morpheme is an argument that receives an external θ -role and accusative Case. In this way, the passive morpheme is compatible with only verbs that assign both an external θ -role and accusative Case (see Fujita and Matsumoto (2005)). Under our proposal in chapter 2, the head of VoiceP that the light verb in (60) can select is only $-\emptyset$, and it cannot

select *-en*.¹⁶ Accordingly, PRC, as in (59), does not have the passive counterpart. The sentences in (51), (53), (55), (56b), (57b), and (58) are ungrammatical because they are the passive of PRC. Since CIT is irrelevant to the ungrammaticality of these sentences, they cannot serve as counterexamples to our proposal.

3.6.2. Unaccusative Idioms

We have claimed that idiom chunks cannot be raised to SPEC-T, but how can we explain the following sentence?

- (62) Hara-ga tat-ta.¹⁷
 stomach-Nom stand-Past
 ‘One felt irritated.’

It seems that the idiom chunk *hara* is raised to SPEC-T because it is at the sentence-initial position. This idiom might be a counterexample to our proposal.

There are many unaccusative idioms in Japanese, such as *me-ga iku* ‘get attracted’, *te-ga kakaru* ‘need efforts’, and *keti-ga tuku* ‘be criticized’. Kishimoto (2010) suggests that the nominative subject is not raised to SPEC-T in these idioms.

Kishimoto uses the *bakari*-construction as a diagnostic to clarify the syntactic position of arguments. Let us consider the following

¹⁶ Hasegawa (2001, 2004) proposes two light verbs in addition to the transitive light verb *v** and the intransitive light verb *v*. Here, I assume that the light verb in (60) has almost the same lexical property as the intransitive light verb.

¹⁷ Koji Fujita pointed out this example to me.

sentence:

- (63) Kodomo-ga manga-o yon-de-bakari i-ru.
child-Nom comic-Acc read-Ptcp-only be-Pres
'The child is only reading the comics.'

(Kishimoto (2010: 631))

According to Kishimoto's analysis, in (63), *bakari* 'only' is an adverbial particle attached to AspP, which selects *v*P. The object is c-commanded by *bakari*, but the subject is not. Therefore, *bakari* can associate with the object but not the subject in (63). In other words, *bakari* can be associated with elements included within *v*P, but not those elements residing in TP.

This diagnostic can tell us whether an argument is within *v*P or not. Kishimoto suggests that not only the object in (64a) but also the subject in (64b), which is the intransitive counterpart of (64a), are within *v*P.

- (64) a. Mary-ga kodomo-no sewa-ni te-o
Mary-Nom child-Gen care-Dat hand-Acc
kake-te-bakari i-ta.
hang-Ptcp-only be-Past
'Mary was putting efforts on only the child care.'
- b. Kodomo-no sewa-ni te-ga kakat-te-bakari
child-Gen care-Dat hand-Nom hang-Ptcp-only
i-ta.
be-Past
'Only the child care needed efforts.'

(ibid.: 653)

In both variants of the idioms, the *ni*-marked PP can be the focus of *bakari*. This means that the PPs are inside *vP*, and that the idiom chunks *te-o* in (64a) and *te-ga* in (64b) are also inside *vP*, since the idiom chunks must follow the PPs. We can therefore confirm that the nominative subject is not raised to SPEC-T in (64b).

Now let us return to (62). This idiom has the transitive counterpart, as in (65), and the *ni*-marked PPs can be the focus of *bakari* in both (66a) and (66b), which represent the transitive-intransitive pair.

(65) Taroo-ga Hanako-ni hara-o tate-ta.
 Taro-Nom Hanako-Dat stomach-Acc stand-Past
 ‘Taro felt irritated with Hanako.’

(66) a. Taroo-ga Hanako-ni hara-o
 Taro-Nom Hanako-Dat stomach-Acc
 tate-te-bakari i-ta.
 stand-Ptcp-only be-Past
 ‘Taro felt irritated with only Hanako.’

b. Hanako-ni hara-ga tat-te-bakari i-ta.
 Hanako-Dat stomach-Nom stand-Ptcp-only be-Past
 ‘One felt irritated with only Hanako.’

Therefore, the nominative subject, i.e. the idiom chunk *hara*, is not raised to SPEC-T, and the acceptability of (62) does not contradict our proposal.¹⁸

¹⁸ It is unclear what is raised to SPEC-T in (62). Kishimoto (2010) suggests that, in Japanese, the EPP feature is not assigned to T if the subject is not a full-fledged argument, i.e. an idiom chunk; however, the EPP requirement is

3.7. Conclusion

In this chapter, we have observed that there are two types of idioms in English and Japanese: Type I idioms and Type II idioms. Type I idioms have only idiomatic readings and can passivize, while Type II idioms have literal readings as well as idiomatic readings and cannot passivize. These differences arise because idiom chunks in Type II idioms are assigned the special θ -role *i* and phrases assigned this θ -role cannot be raised to SPEC-T. English is an agreement-prominent language where the nominative subject is obligatorily raised to SPEC-T. The argument located in the domain of TP is interpreted as topic at the interface by the informational structure in (42), and thus Type II idioms cannot passivize in English. On the other hand, Japanese is a focus-prominent language where phrases other than the nominative subject can be raised to SPEC-T. Therefore, Type II idioms can passivize in Japanese, provided the idiom chunk stays at SPEC-*v**. These idioms can appear only in *niyotte* passives, not in *ni* direct passives, and we can conclude that it is possible to passivize Japanese idioms. Hoshi's (1991) claim that *niyotte* passives correspond to *be* passives in English is thus correct, contrary to Mihara and Hiraiwa's (2006) observation. In addition, by adopting Hasegawa's (2001) analysis that the external argument is not projected in PRC, we can explain why the idioms that refer to parts of the human body are

always imposed on finite T in English. I assume that (62) is a kind of PRC, and that *pro* is raised to SPEC-T as the inalienable possessor of *hara*.

unpassivizable. Furthermore, we can claim that the subject of unaccusative idioms is not raised to SPEC-T based on Kishimoto's analysis of the *bakari*-construction.

CHAPTER FOUR

ON PSEUDOPASSIVES AND THE CASE ASSIGNMENT OF P¹

4.1. Introduction

Passivization has been treated as an operation that raises the object of a transitive verb to the subject position in the generative grammar. This means that it is the internal argument of a verb that can be the subject of a passive sentence, as in (1).

- (1) a. John kissed Mary.
b. Mary_i was kissed *t*_i (by John).

In addition to the internal argument of a verb, however, the complement of a preposition can also be the subject of a passive sentence, as in (2).

- (2) a. John talked to Mary.
b. Mary_i was talked to *t*_i (by John).

Passive sentences of this kind are called “pseudopassives.” It is said that pseudopassives can be found only in a certain number of languages such as English. A preposition *per se* assigns Case to its

¹ Earlier versions of this study were presented at the 81st General Meeting of the English Literary Society of Japan, held at the University of Tokyo (May 2009), and in Honda (2010b). I am indebted to Nobuko Hasegawa, Ken-ichi Takami and the audience at the meeting for their invaluable comments and suggestions. I would like to especially express my sincere gratitude to Yukio Oba and Sadayuki Okada for helping me from the outset of this study. I would also like to thank Koji Fujita, Masaharu Kato, Mayumi Yoshimoto and Koji Shimamura for their helpful comments. Needless to say, all remaining inadequacies are mine.

complement, and the Case of the preposition seems to remain under passivization. Thus, it is a mystery why the complement of the preposition *Mary* can be passivized, as in (2b).

In addition to pseudopassives, all kinds of phenomena that move the complement of a preposition leaving the preposition behind are called “preposition stranding (P-stranding).” Example (3) corresponds to another type of P-stranding:

- (3) a. Who_i did you talk to t_i?
b. *[What time]_i did John arrive at t_i?

If we adopt Abels’ (2003) term, (3a) is an instance of P-stranding under \bar{A} -movement, whereas (2b) is an instance of P-stranding under A-movement, i.e. the pseudopassive.

Within early Government and Binding theory, if we assumed that S and PP are bounding nodes, we could explain the unacceptability of (3b). The *wh*-element would have to cross both PP and S before moving to COMP, which violates Subjacency. This proposal, however, is problematic because it cannot account for the grammaticality of (3a). Thus, we must find a way to explain the grammaticality of (3a) and the ungrammaticality of (3b) simultaneously.

In order to treat P-stranding under A- and \bar{A} -movement, as in (2b) and (3a), respectively, as a licit operation, Hornstein and Weinberg (1981) (henceforth, H&W) assume a universal filter of the form in (4) and a syntactic rule called “Reanalysis,” as in (5).

- (4) *_[NP e_{oblique}]
(5) V → V* (where V c-commands all elements in V*)

According to their proposal, the filter shown in (4) states that noun phrases with no lexical material (e.g. traces) that are marked oblique by the Case-marking conventions are to be ruled out as ungrammatical. The Case-marking rules that they adopt are listed in (6).

- (6)
- a. NP is marked [+nominative] if it is governed by tense, i.e., if it is marked the subject of a tensed sentence.
 - b. NP is marked [+objective] if it is governed by V.
 - c. NP is marked [+oblique] if it is governed by P.
 - d. *Wh*-NPs are assigned the Case of the closest trace which bears their index and which is in a possible Case position. Both the *wh*-element and the relevant trace are marked with Case.

Furthermore, (5) states that in the domain of VP, a V and any set of contiguous elements to its right can form a complex V. Note that it is necessary for the element that is to be reanalyzed into a complex VP to be not only linearly adjacent but also c-commanded by V. Since the PP in (3b) is not c-commanded by V, as shown in (7), Reanalysis does not occur and the trace in (3b) remains [+oblique].

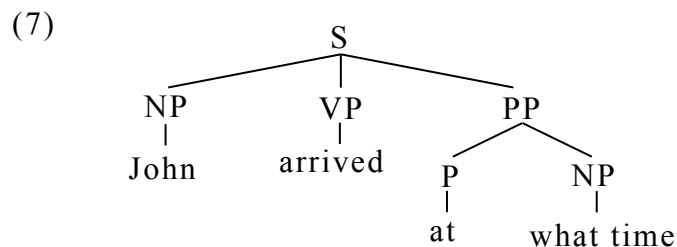

Thus, (3b) is ruled out by the filter in (4).

On the other hand, the PP in (3a) is c-commanded by V, as in (8), which makes it possible for the string *talk to* to become a complex verb,

and the trace in (3a) is assigned objective Case; hence, no violation of (4).

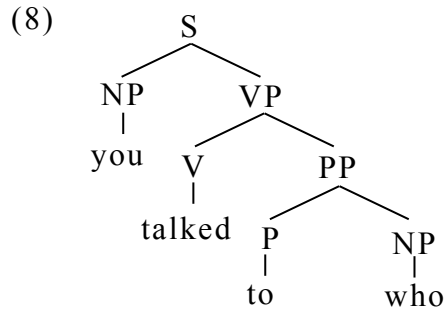

Furthermore, H&W's proposal also accounts for the derivation of the pseudopassive, as in (2b), repeated below as (9).

(9) Mary_i was talked to *t_i* (by John). (= (2b))

Since the PP in (9) is within the c-command domain of V, the string *talk to* can be reanalyzed as a complex verb. Consequently, the Case assigner to *Mary* is not the preposition *to* but the complex verb *talk to*. Now *Mary* becomes the internal argument of the complex verb. In passive constructions, a verb loses its Case assigning property, and the internal argument of the verb agrees with T and is raised to SPEC-T, being assigned nominative Case. In the derivation of (9), the complex verb *talk to* cannot assign accusative Case to its internal argument *Mary*, and it thus agrees with T and is raised to SPEC-T. This is why the once complement of the preposition can be passivized in (9).

According to the rule in (5), prepositions that are not c-commanded by V cannot be reanalyzed into a complex verb. Since pseudopassive sentences are derived via Reanalysis, (10a) is not a possible pseudopassive sentence, where the PP is not in the c-command domain of V, as illustrated in (10b).

(10) a. *Tuesday was departed on by Bill.

(Culicover and Jackendoff (2005: 207))

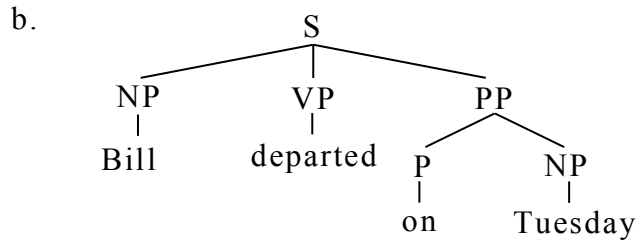

According to H&W, the combination of (4) and (5), however, does not suffice to predict the grammaticality of pseudopassives. The condition on P-stranding under A-movement is more rigid than that on P-stranding under \bar{A} -movement, as illustrated in (11).

(11) a. *The table_i was put the mouse on t_i.

b. What table_i did Harry put the mouse on t_i? (H&W: 65)

H&W claim that the reanalyzed word in the case of pseudopassives must be a possible semantic word. Although *talk to* in (9) is a possible semantic word, *put the mouse on* is not; hence, the deviance of (11a). Such a restriction is irrelevant to P-stranding under \bar{A} -movement, as in (11b).

Indeed H&W's analysis accounts for P-stranding phenomena elegantly, but there are some counterexamples (Baltin and Postal (1996), Inada (1981), among others), which show that prepositions are not reanalyzed into complex verbs but still remain independent of verbs in P-stranding sentences.

The aim of this chapter is to account for the derivation of the pseudopassive without resorting to Reanalysis. In addition, I will explain P-stranding under \bar{A} -movement in the same vein.

The organization of this chapter is as follows. In section 4.2, I introduce the distinction between pseudopassives and peculiar passives, which look as if they had the same syntactic structure as pseudopassives but are derived in a quite different way. In section 4.3, I point out some problems in H&W's analysis. In section 4.4, I discuss how prepositions assign Case to their complements and how pseudopassive sentences are derived. Section 4.5 demonstrates that the proposed analysis can adequately explain the derivation of pseudopassives. In section 4.6, I discuss P-stranding under \bar{A} -movement. In section 4.7, I explain why some languages do not allow P-stranding. Section 4.8 presents the conclusion of this chapter.

4.2. Pseudopassives and Peculiar Passives

4.2.1. Takami (1992)

Takami (1992) claims that H&W's notion that the reanalyzed word in the pseudopassive must be a possible semantic word is untenable, pointing out the examples in (12).

- (12) a. This river should not be swum in.
b. This brand-new fountain pen has never been written with.

(Takami (1992: 101))

H&W consider that the meanings of strings of words that are semantic words are noncompositional. However, it is obvious that the meanings of the strings *swim in* and *write with* are compositional.

Considering these examples, Takami offers a comprehensive explanation to pseudopassives with the condition, as in (13).

(13) Characterization Condition for Pseudo-Passives:

A pseudo-passive sentence is acceptable if the subject is characterized by the rest of the sentence; namely, if the sentence as a whole serves as a characterization of the subject. Otherwise, it is found unacceptable, or marginal at best.

(Takami (1992: 126))

According to his analysis, the sentences in (12) inform us that the river is dangerous to swim in and that the fountain pen has never been used by anyone. Consequently, (12a) and (12b) characterize the subjects *this river* and *this brand-new fountain pen*, and both are acceptable pseudopassive sentences.

A similar kind of analysis can be found in Culicover and Jackendoff (2005). They state that prepositional passives seem generally possible when the verb and preposition together denote the (surface) subject's proper function, taking up the following examples:

- (14) a. This bed has been slept in/*under.
b. The sofa has been sat on/*beside.

(Culicover and Jackendoff (2005: 208))

However, Takami himself points out that the Characterization Condition cannot account for the pseudopassive sentences in (15) because none of the subjects are characterized by the rest of the sentences:

- (15) a. This question will be dealt with later in the book.
b. I was spoken to by a stranger.
c. Mike was laughed at by Mary. (Takami (1992: 136))

Takami claims that the acceptability of these sentences should be explained by Kuno's (1989) Semantic Condition for Passivization in English, which accounts for the acceptability of single-verb passive sentences. This suggests that there are at least two kinds of pseudopassives: One shows an idiosyncratic property to pseudopassives, and the other shares the same property as single-verb passives.

Furthermore, even if Takami's analysis is correct, it is still a mystery how pseudopassive sentences are syntactically derived. It remains unsolved how to attract the complement of prepositions that has been assigned Case to SPEC-T before the agreement with T if Reanalysis does not occur.

4.2.2. Kageyama and Ura (2002)

Kageyama and Ura (2002) (henceforth, K&U) define the three terms "prepositional passive," "pseudopassive," and "peculiar passive," making a distinction between pseudopassives and peculiar passives, which are both subsumed under the superficial nomenclature of prepositional passive.

According to their distinction, PPs in pseudopassives are governed by the passivized verbs and reanalyzed with the verbs, but PPs in peculiar passives are adjuncts, as in (16), where Reanalysis is not triggered.

(16) This spoon has been eaten with. (K&U: 183)

This distinction tells us that the examples that H&W present are all pseudopassives, while the counterexamples to H&W that Takami (1992)

takes up are peculiar passives.

Note that the combination of verbs and adjunct prepositions does not freely generate peculiar passive sentences; otherwise, (10a), repeated here as (17), would be acceptable.

(17) *Tuesday was departed on by Bill.

Then, what is the difference between (16) and (17)?

K&U claim that the difference between pseudopassives and peculiar passives is that the predicate in the former expresses a stage-level (or particular) predication while that in the latter represents an individual-level (or characterizing) predication. It is the individual-level status that is the essential ingredient of the peculiar passive formation.

The next question is when individual-level predications are expressed. According to their analysis, one case is when the present perfect aspect is involved, as in the well-formed peculiar passive (16). Note that if we change the present perfect into the simple past tense, the resulting sentence is unacceptable, as illustrated in (18).²

² One might claim that there exist some peculiar passives that do not express individual-level predications. However, it is dubious that those examples are really acceptable. The sentence in (i) illustrates the case in point:

(i) (*) This building was walked in front of by the Japanese Emperor last month. (Takami (1992: 108))

Takami treats this example as an acceptable sentence, but K&U conclude this to be unacceptable or, at the very best, highly marginal, based on their informants' judgment. K&U claim that the sentence can be salvaged if an adverb with quantificational force such as *always* or *often* is substituted for *last month*, as in (ii).

(ii) a. This building is always walked in front of by the Japanese

(18) *This spoon was being eaten with. (K&U: 185)

The other case is when peculiar passives appear with the modal auxiliaries like *can* and *should*, as in (19).

- (19) a. This violin can be played any sonatas on.
b. This pub should not be smoked hash in. (ibid.: 188)

These modals only imply possibilities and probabilities instead of entailing the actual occurrence of the events expressed in the propositions, which makes the sentences express individual-level predications.

As regards the syntactic structure of peculiar passives, K&U suggest (20) as the structure of (16).

(20) This spoon_k has been [eaten [with *pro*_k]] (ibid.: 192)

They argue that the subject of the peculiar passive is base-generated in SPEC-Infl and controls a phonologically null element, i.e. *pro*, which is the complement of a preposition. Moreover, based on K&U's analysis, Ura (2005) proposes that the syntactic derivation of peculiar passives is as follows in (21):

Emperor.

- b. This building was often walked in front of by the Japanese Emperor. (K&U: 186)

The examples in (ii) increase in acceptability because the adverbs *always* and *often*, acting as unselective quantifiers, can prompt the individual-level interpretation of the predicate they modify.

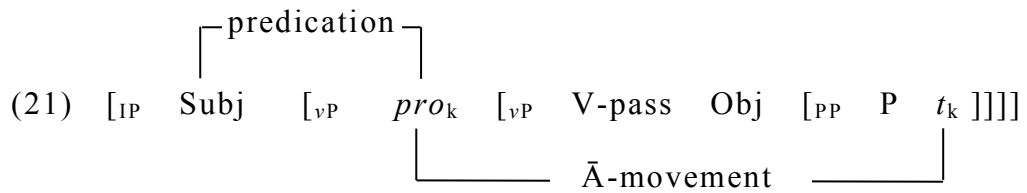

(Ura (2005: 285))

In (21), *pro* Ā-moves to the edge of *vP*, which generates a derived predicate. The subject of the peculiar passive is assigned the theta-role by this derived predicate.

In summary, peculiar passives are quite different from pseudopassives, regardless of their surface similarities. Only the complements of the prepositions that are also complements of verbs can be the subject of pseudopassives. Most prepositional passive sentences that have been regarded as the counterexamples to H&W are peculiar passives and are not really counterexamples. Thus, we must present only pseudopassive sentences as counterexamples to H&W. In the next section, I will analyze such examples.

4.3. Against Reanalysis

In this section, I will present some pseudopassives that are unable to be explained if we assume Reanalysis.

4.3.1. Baltin and Postal (1996)

Baltin and Postal (1996) show (22)–(25) as counterexamples to Reanalysis:

- (22) a. I discussed *t*₁ with Lorenzo – [the problems he was having with deliveries]₁.

- b. *I argued with t_2 about such problems – [the drivers' union leader]₂. (Baltin and Postal (1996: 129))
- (23) a. Frank called Sandra and Arthur ____ Louise.
 b. Frank talked to Sandra and Arthur ____ *(to) Sally. (ibid.)
- (24) a. Frank called Sandra more often than Arthur did ____ Louise.
 b. Frank talked to Sandra more often than Arthur did ____ *(to) Louise. (ibid.)
- (25) a. The bridge was flown (both) over and under.
 b. Communism was talked, argued, and fought about. (ibid.: 130)

It is known that the complement of verbs can undergo heavy DP (NP) shift, as in (22a). In contrast, (22b) shows that the complement of prepositions cannot undergo heavy DP shift. Since (26) is acceptable, the string *argue with* must be a possible predicate and function as a complex verb.

- (26) ?John was argued with. (Drummond (2011: 174))

If *argue with* were reanalyzed as a complex verb, we could not explain why (22b) is unacceptable.

The asymmetry in (23) is also problematic to Reanalysis approaches. Although a verb can be deleted under gapping, it is impossible for the preposition to be deleted independently of its object, as in (23b). If the preposition were reanalyzed with the verb, it could be deleted contrary to fact. The same phenomenon can be found in the ellipsis associated with

comparatives like (24). Again, the preposition cannot be deleted independently of its complement in the pseudopassive.

The examples in (25) also indicate that the preposition apparently behaves as an independent element.

The above examples can be accounted for only if the prepositions remain independent of the verbs. In this respect, we can claim that Reanalysis approaches are untenable.

4.3.2. Inada (1981)

Inada (1981) shows some examples that cannot be accounted for if we assume Reanalysis, and points out some problems with H&W's analysis.

First, Inada claims that it is obscure when and where Reanalysis is applied in the derivation of sentences such as (27c).³

- (27) a. John talked to Harry about Christianity.
b. Harry_i was talked to *t_i* about Christianity.
c. What_j was Harry_i talked to *t_i* about *t_j*? (Inada (1981: 124))

Since (27b) is a well-formed pseudopassive sentence, the string *talk to* must be reanalyzed into a complex verb in (27c), but, at the same time, the string *talk to t_i about* must be reanalyzed; otherwise, the trace *t_j* is assigned oblique Case, which violates the filter (4), which I repeat as (28).

(28) *_[NP e_{oblique}]

³ H&W claim that sentences like (27c) are not fully acceptable, but see Inada (1981: fn. 8).

Moreover, if the string *talk to t_i about* is reanalyzed, it is dubious that *Harry* can be raised from the complex verb.

Second, Inada points out a problem with (28). If Reanalysis does not occur, the complement of a preposition cannot undergo \bar{A} -movement because of the filter in (28). He takes up the following as counterexamples to this notion:

- (29) a. Who are_i you *t_i* suspicious of?
b. What was_j the teacher *t_j* concerned with?
c. Which client was_k the lawyer *t_k* uncertain about?

(Inada (1981: 125))

Since Reanalysis is an operation through which a verb and material that is right adjacent to it become a new complex verb, the verb must be a member of the reanalyzed elements. The acceptability of (29) shows that Reanalysis has occurred in the sentences. Nevertheless, the verb *be* is moved out of the complex verb under Subject-Auxiliary Inversion. Accordingly, the sentences in (29) would be incorrectly filtered out by (28), if H&W's analysis were correct.

Third, Inada points out that H&W's analysis cannot predict the following contrast:

- (30) a. John insisted on your being here on time. (ibid.: 127)
b. *John insisted on that you be here on time. (ibid.)
c. John insisted that you be here on time.

(Rosenbaum (1967: 83))

- d. That you be here on time was insisted on by John. (ibid.)

e. *That you be here on time was insisted by John.

(Rosenbaum (1967: 83))

Since the well-formed passive sentence is (30d) not (30e), the string *insist on* must be reanalyzed into a complex verb. However, the complex verb cannot take a *that*-clause in the active, as in (30b). On the contrary, the single verb *insist* can take a *that*-clause in the active, as in (30c), although its passive counterpart is unacceptable, as shown in (30e). This shows the V-P string does not constitute a syntactic unit at any grammatical level, and this intriguing contrast casts doubt on the existence of the Reanalysis rule.

In summary, it is tough to assume that a verb and a preposition are reanalyzed into a complex verb in P-stranding under A- and \bar{A} -movement. Alternatively, it is plausible to assume that prepositions still remain independent elements throughout the derivation of P-stranding under A- and \bar{A} -movement sentences. The problem is how to extract the complement of prepositions without counting on Reanalysis.

4.4. Proposal

As we have seen above, it is necessary to find the way to derive P-stranding sentences without resorting to Reanalysis. In the derivation of pseudopassives, it is unclear why the complement of a preposition is not assigned Case by the preposition but agrees with T. In the next subsection, I propose a new Case assignment system of prepositions.

4.4.1. The Case Assignment of Prepositions

In the Minimalist Program framework (Chomsky (2008) and others), it is assumed that structural Case is assigned to DP when the DP agrees with an Agree-feature. Chomsky (2008) proposes that only phase heads, such as C or v^* , have such a feature. Moreover, he suggests that T inherits an Agree-feature from C, while V inherits one from v^* . Then, what agrees with T is raised to SPEC-T and assigned nominative Case, and what agrees with V is raised to SPEC-V and assigned accusative Case.

How do prepositions assign Case to their complements? I assume that unlike C or v^* , P does not have any Agree-features, although it can assign Case to its complement. There is not such a phase head that transmits its Agree-feature to P. In addition, I assume that P itself is not a phase head at least in the languages that allow pseudopassives because the complement of P could not be extracted, as in pseudopassive sentences, if PP were a phase.⁴ Moreover, if Chomsky's analysis is on the right track, the DP that is assigned Case and what inherits the Agree-feature from a phase head must be in the Spec-Head relation. Such configurations cannot be assumed between P and its complement. Thus, P assigns Case to its complement in a quite different way from C or v^* .⁵

⁴ As we will see in 4.7, I assume that in languages that disallow P-stranding, PPs are phases, adopting Drummond, Hornstein and Lasnik (2010).

⁵ One might argue that P assigns inherent Case to its complement. Inherent Case assignment does not require the Spec-Head relation. However, if P assigned inherent Case to its complement, the pseudopassive would be

Taking this into consideration, I propose that P assigns Case to its complement according to the rules in (31).

- (31) a. The DP that is adjacent to P at Spell-Out is incorporated into the P.
- b. P assigns oblique Case to DP if the DP is incorporated into the P.

I assume that P does not agree with its complement, but that DP is assigned Case by incorporation into P. Only the adjacency between P and its complement is required so that the P can assign Case. Thus, P does not assign Case to DP when the DP is not adjacent to the P. I will show some evidence that supports this unusual Case assignment in section 4.7.

4.4.2. Deriving the Passive

As I have proposed in chapter 2, both active transitive sentences and passive sentences are derived from the base structure in (32).

- (32) [_{v*P} EA [_{v*} [_{VoiceP} Voice [_{VP} V IA]]]]

EA = external argument, IA = internal argument

In (32), the functional head Voice is assumed above VP, which determines whether the sentence is active or passive. The Voice of actives is $-\emptyset$, which is a phonetically null element, but the Voice of passives is the passive morpheme *-en*. To support this claim, I propose the conditions in (33).

impossible because T cannot agree with the element that has already been assigned Case.

- (33) a. v^* merges DP iff v^* selects $-\emptyset$.
 b. v^* merges IMP and is assigned an EPP-feature iff v^* selects *-en*.

According to Matsuoka (2003), v^* is assigned an EPP-feature in the passive, and I adopt his proposal. I propose that IA in (32) is raised to SPEC- v^* above EA in passives. Moreover, EA is DP in actives but it is *IMP* in passives, which is a phonetically null element.

Accordingly, the syntactic structures of (34a) and (35a) correspond to (34b) and (35b), respectively.

- (34) a. John talked to Mary.

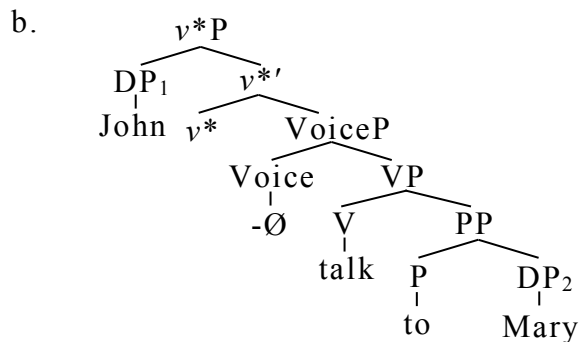

- (35) a. Mary was talked to.

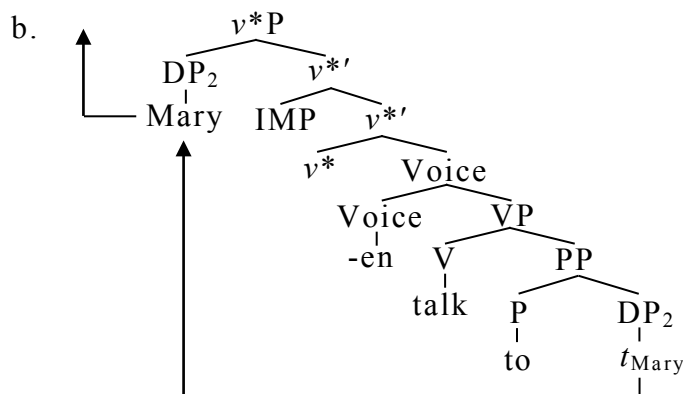

In both (34b) and (35b), V adjoins to Voice, and V-Voice complex adjoins to v^* . In addition, I propose that V agrees with a phonetically null element, i.e. a cognate object, because unergative verbs can take

cognate objects as complements.^{6, 7}

In (34b), the PP *to Mary* is in the v^*P phase domain. If we adopt Hiraiwa's (2005) Multiple Agree, *Mary* is accessible to V, which inherits an Agree feature from v^* , and thus it is possible for V to agree with *Mary*. However, since *Mary* in (34b) is adjacent to the preposition *to*, it is incorporated into *to* and assigned oblique Case by *to*.⁸

On the other hand, *Mary* in (35b) is raised to SPEC- v^* by the condition in (33b), and it then agrees with T, assigned nominative Case. This operation does not violate the Phase-Impenetrability Condition (PIC), as in (36), because PP is not a phase and the complement of P is accessible to v^* .

(36) Phase-Impenetrability Condition

In phase α with head H, the domain of H is not accessible to operations outside α , only H and its edge are accessible to such operations. (Chomsky (2000: 108))

Note that *Mary* is not adjacent to the preposition *to* in (35b). Therefore, *Mary* is not assigned Case by *to*, and T can assign nominative Case to it.

⁶ According to Fujita and Matsumoto (2005), unergative verbs take cognate objects as complements, as shown in (i).

(i) [v^*P DP [v^* v^* [v_P V CO]]]

Thus, the precise base-structure for (34) and (35) is as follows in (ii):

(ii) [v^*P John [v^* v^* [$voice_P$ Voice [v_P [v' V CO] [PP *to Mary*]]]]]

⁷ According to Omuro (2005), the verb *talk* can take a cognate object.

⁸ This means that there remains a possibility that *Mary* in (34b) is assigned Case by V if it leaves the complement position of P before Spell-Out. I will present some evidence that supports this possibility in section 4.7.

4.4.3. Non-Existent Pseudopassives

Chomsky (2004) argues that adjunction is different from simple merge in that the former forms an ordered pair. When α adjoins to β , α attaches to β on a separate plane, with β retaining all its properties on the “primary plane,” the simple structure. This indicates that adjuncts are invisible to the operation in the primary plane. Thus, an adjunct is not in the search domain of the probe.

H&W claim that sentences like (10a), repeated here as (37), are ungrammatical because the PP is not in the c-command domain of the verb, where Reanalysis cannot occur.

(37) *Tuesday was departed on by Bill. (= (10a))

However, if we adopt Chomsky’s (2004) analysis, we find that Reanalysis is irrelevant to the ungrammaticality of (37). We can conclude that *Tuesday* is not accessible to any probe outside the PP. Therefore, the complement of an adjunct PP cannot be the subject of the pseudopassive, and there is no need to resort to Reanalysis.⁹

⁹ Yukio Oba points out to me that there are some exceptional examples where *wh*-phrases are extracted from adjunct PPs, as shown in (i).

- (i) a. What did you do it for?
b. Who did you go with?

As Sano (1983) observes, even the extraction from temporal PPs, which H&W consider to be impossible, is possible if the PPs are perceived to have some relevance to what is described in the rest of the VP. See (ii).

- (ii) a. What day will he fly to Paris on?
b. What time does John go to class at?
c. Which vacation did John visit his aunt in? (Sano (1983: 108))

It may be possible to assume that these PPs are not adjuncts, but it is difficult to determine whether they are adjuncts or not because the diagnostic to distinguish adjuncts from complements is the extraction of *wh*-phrases. I

Furthermore, the proposal here does not require the notion “possible semantic words,” which is assumed only for P-stranding under A-movement.

- (38) a. *The table was put the mouse on. (= (11a))
 b. *John was talked to Harry about. (H&W: 65)

The ungrammaticality of the sentences in (38) is ascribed to the violation of the Minimal Link Condition, described in (39).

(39) Minimal Link Condition

K attracts α only if there is no β , β closer to K than α , such that K attracts β . (Chomsky (1995: 311))

As illustrated in (40), what is closer to the probe v^* is not *the table* but *the mouse*, as the latter asymmetrically c-commands the former.

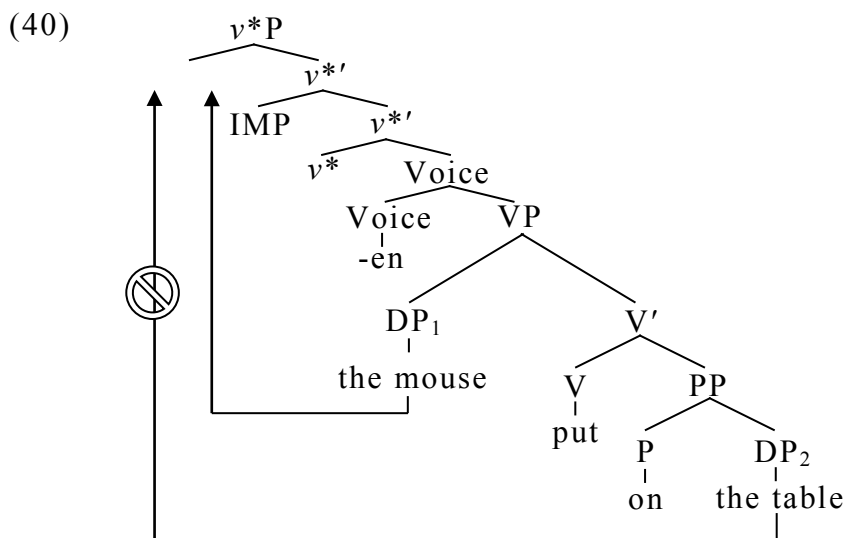

Thus, (41b) is derived as the passive counterpart to (41a).¹⁰

leave these exceptions for future research.

¹⁰ I assume that *advantage* in the idiom *take advantage of* can be either DP or NP. I suggest that *advantage* in (i) is NP.

(i) John was taken advantage of.

According to Fujita and Matsumoto (2005), NP is incorporated into V, and it

- (41) a. We put the mouse on the table.
 b. The mouse was put on the table.

The same analysis can be applied to (38b), which is unacceptable because *Harry* is closer to v^* than *John*, as in (42).¹¹

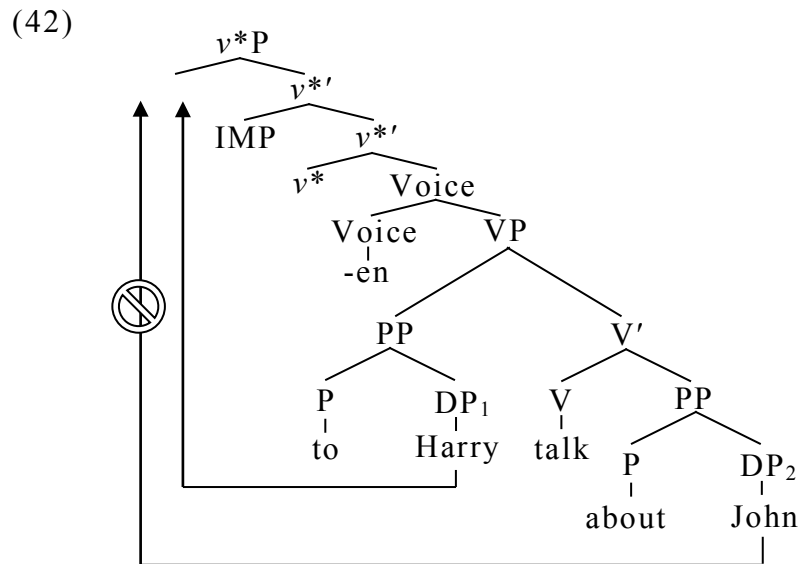

Harry intervenes between v^* and *John*. This is why (38b) is ungrammatical.

does not intervene between v^* and the complement of the preposition *of*. This is why passive sentences like (i) are possible. On the other hand, *advantage* in (ii) is not an NP but a DP; thus, it is raised to the subject position.

- (ii) Advantage was taken of John.

¹¹ In a strict sense, it may be doubtful whether *Harry* is closer than *John* because the former does not c-command the latter. However, based on (i) and (ii), we can assume that the preposition *to* is invisible to c-commanding.

- (i) a. Mary talked to Bill about himself on Tuesday.
 b. *Mary talked about Bill to himself on Tuesday.

(Drummond (2008: 1))

- (ii) a. I talked to John and Bill about themselves/each other.
 b. ??I talked about John and Bill to themselves/each other.

(Jackendoff (1990: 431))

In this chapter, I tentatively assume that *Harry* c-commands *John* in (42).

4.4.4. Languages That Do Not Allow Pseudopassives

Abels (2003) proposes that the phase nature of P is subject to parameterization, and that Ps are phase heads in the languages that disallow P-stranding.¹² I adopt Abels' proposal, and I suggest that the PIC accounts for why pseudopassivization is impossible in some languages. In the languages where PPs are phases, the complement of P is not accessible to probes outside the PP. Thus, the complement of P is inaccessible to v^* , as illustrated in (43).¹³

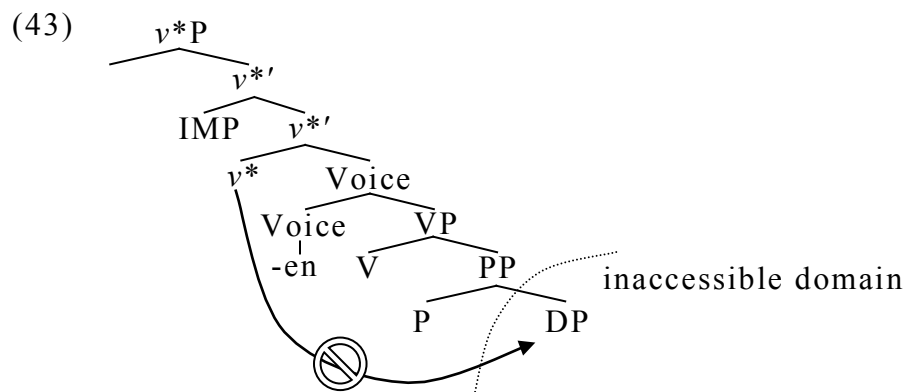

It is essential for the EPP-feature on v^* to agree with the complement of P so as to derive pseudopassives, but this agreement is impossible due to the PIC. In such languages, the complement of P is always adjacent to the P and is assigned oblique Case. Accordingly, pseudopassive sentences are never derived if PPs are phases.

¹² Abels (2003) proposes that P is a phase head for a quite different reason, and his analysis is irrelevant to the PIC. If P is a phase, any *wh*-phrase extracted from PP must move through SPEC-P. He claims that this movement violates an anti-locality condition on movement, which roughly corresponds to a condition that prohibits the complement of a phase head from moving through the specifier of the phase head.

¹³ I assume that P does not have an EPP-feature for A-movement.

In contrast, in the languages where PPs are not phases, the complement of P is accessible to v^* . Thus, pseudopassivization is possible in such languages.

4.5. Some Consequences

As I have proposed in section 4.4, P is not reanalyzed into a complex verb in pseudopassives. Rather, P remains independent of V throughout the derivation of pseudopassives. This proposal can account for the facts that we saw in section 4.3.

Consider (22), which I repeat here as (44).

- (44) a. I discussed t_1 with Lorenzo – [the problems he was having with deliveries]₁.
b. *I argued with t_2 about such problems – [the drivers' union leader]₂. (= (22))

It is known that the complement of a verb can undergo heavy DP shift while that of a preposition cannot. If Reanalysis does not occur between *argue* and *with* in (44b), it is natural that (44b) is not acceptable.

Second, gapping in pseudopassives also receives a natural explanation.

- (45) a. Frank called Sandra and Arthur ____ Louise.
b. Frank talked to Sandra and Arthur ____ *(to) Sally. (= (23))

According to Johnson (2009), gapping sentences are derived by across-the-board raising of the verb to a SPEC-Pred, as in (46).

(46) a. Some will eat beans and others rice.

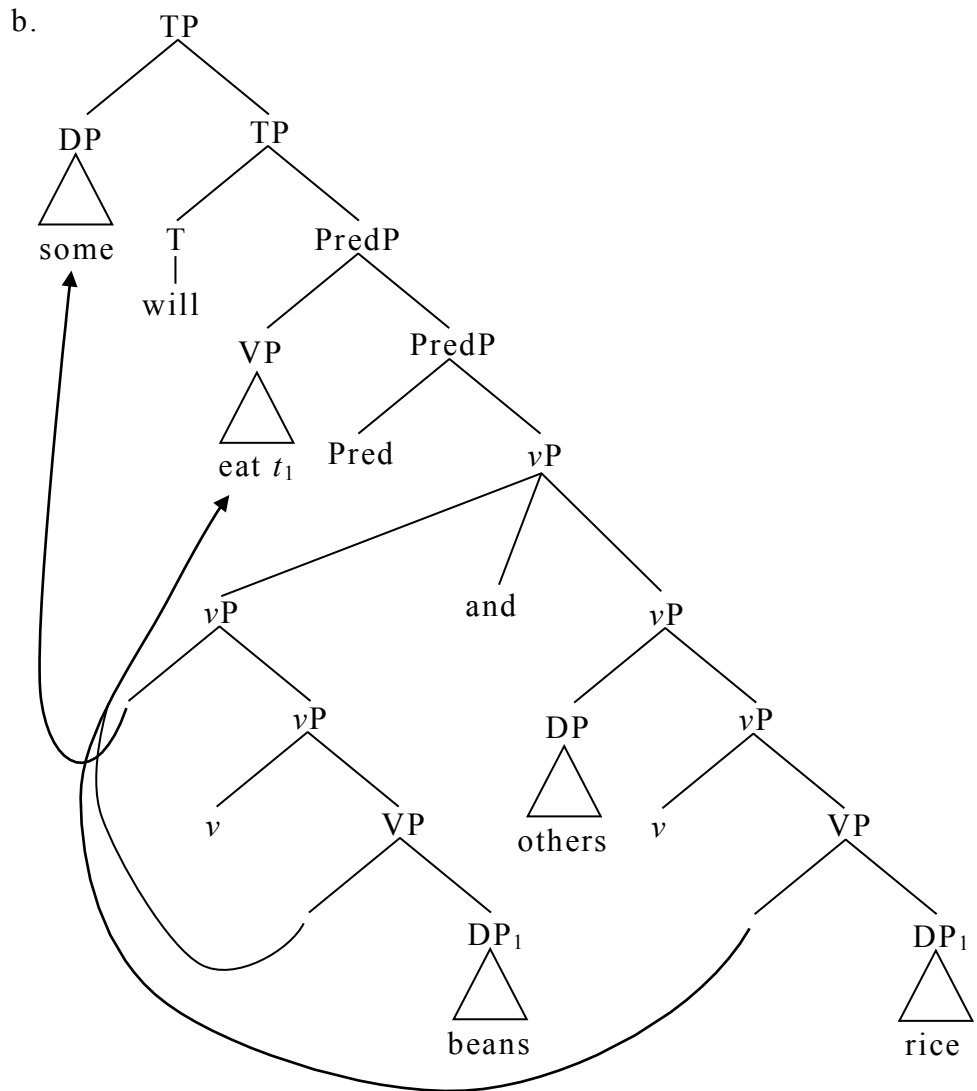

(Johnson (2009: 307))

Based on Johnson's proposal, I suggest (47) as the structure of (45b).

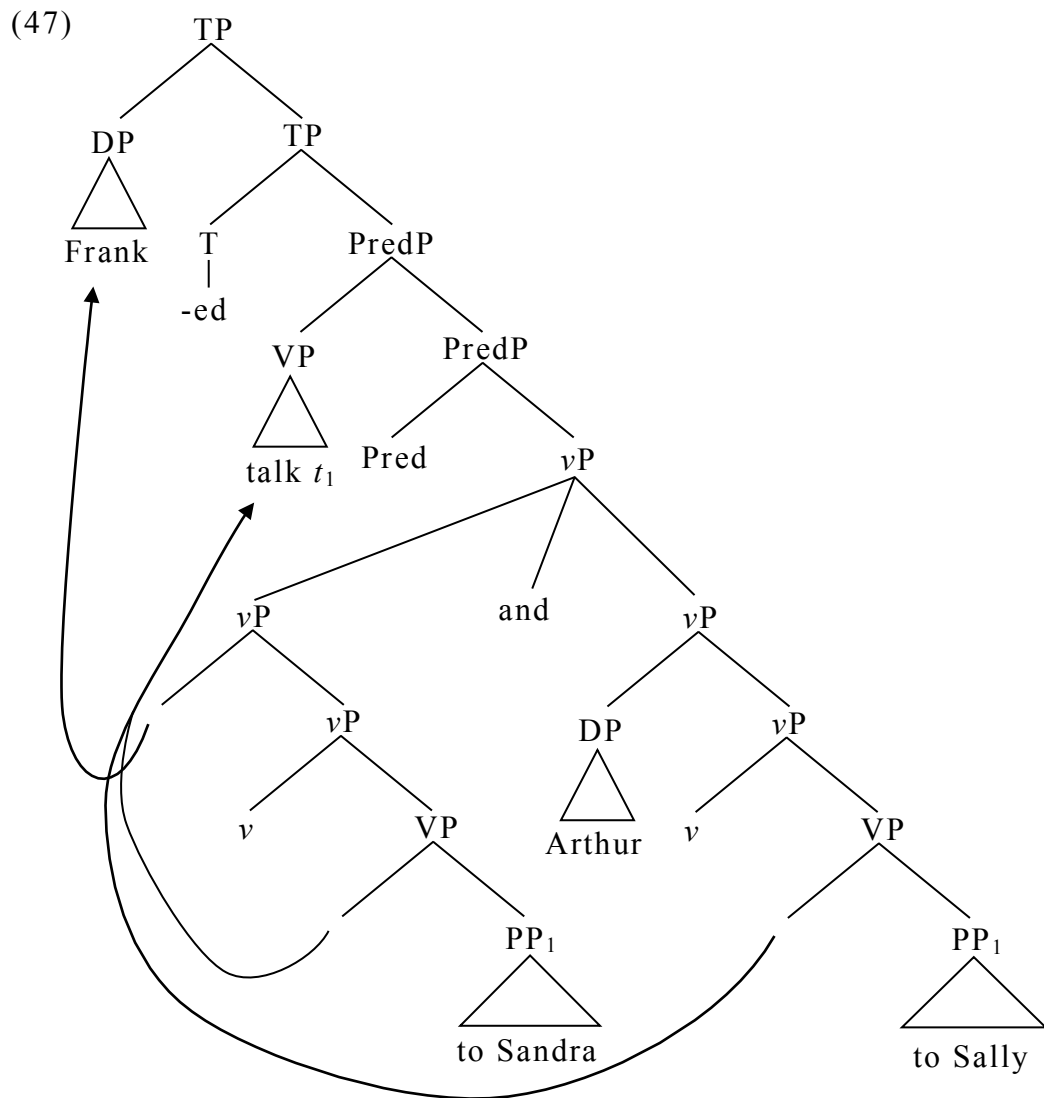

Since P is not reanalyzed with V under the present proposal and there is no such a constituent as [V + P], the string *talk to* cannot be raised. Instead, only the single verb *talk* can be raised to SPEC-Pred. Thus, the P must appear in (45b).

Third, (48) shows examples where comparative subdeletion and pseudogapping have occurred simultaneously.

- (48) a. Frank called Sandra more often than Arthur did _____
 Louise.
- b. Frank talked to Sandra more often than Arthur did _____

*(to) Louise. (= (24))

Comparative subdeletion is caused by deletion of Deg(ree)P.¹⁴ On the other hand, how pseudogapping occurs is controversial.

In Johnson (2009), pseudogapping constructions are assumed to result from VP-ellipsis, with the remnant having moved out of the VP by heavy DP shift. However, there is some evidence that contradicts this analysis.

Lasnik (2003) argues that in the Double Object Construction, only the first object can be the remnant of pseudogapping, as shown in (49).

- (49) a. ?John gave Bill a lot of money, and Mary will ~~give~~ Susan a
lot of money.
b. *John gave Bill a lot of money, and Mary will ~~give Bill~~ a
lot of advice. (Lasnik (2003: 57))

However, as Lasnik points out, it is only the second object that can freely undergo heavy DP shift, as shown in (50).

- (50) a. *John gave *t* a lot of money the fund for the preservation of
VOS languages.
b. John gave Bill *t* yesterday more money than he had ever
seen. (ibid.)

This fact indicates that the remnant of pseudogapping does not undergo heavy DP shift. Alternatively, Lasnik suggests that pseudogapping is caused by VP-ellipsis by assuming overt raising of accusative DP to SPEC-Agr_O. This proposal can account for why *prove guilty*, which is not a constituent, can be elided in (51a).

¹⁴ See Yoshimoto (2008).

- (51) a. The DA proved Jones guilty and Assistant DA will ~~prove~~ Smith ~~guilty~~.

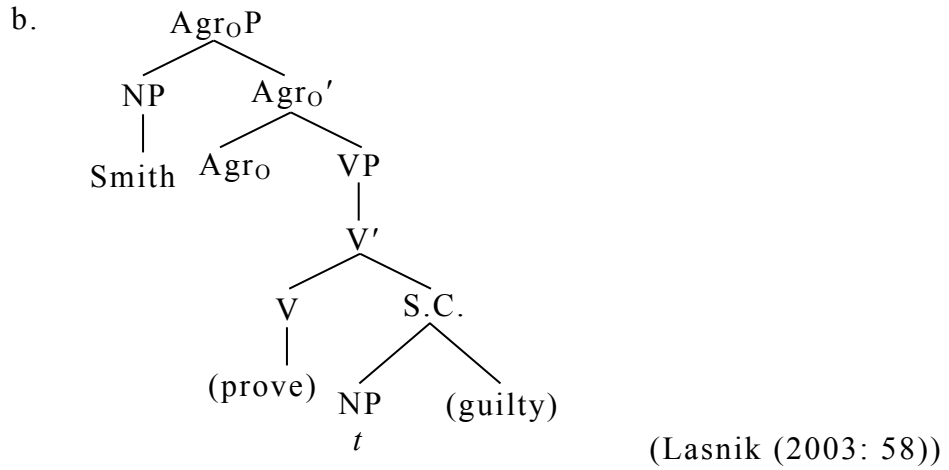

After raising of *Smith* to SPEC-Agr_O, the VP is elided in (51b). Moreover, Lasnik claims that in (52b), deletion of VP₁ results in classic VP-ellipsis, which corresponds to (53a), whereas that of VP₂ results in pseudogapping, as in (53b).

- (52) a. Mary will hire Susan.

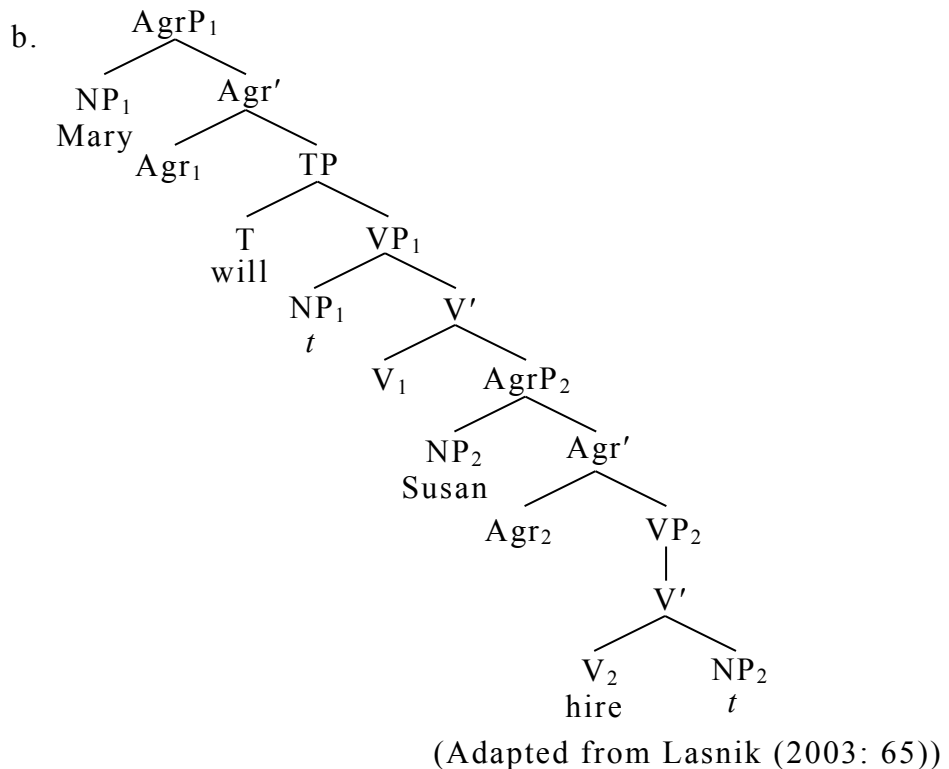

- (53) a. ... Mary will.
 b. ... Mary will Susan. (Lasnik (2003: 66))

The problem is that our framework does not assume the projection of Agr so as to adopt Lasnik's analysis. However, Chomsky (2008) argues that accusative DP is raised to SPEC-V just as nominative DP is raised to SPEC-T, and I assume that this movement corresponds to the raising to SPEC-Agr_O in Lasnik (2003). Thus, the pseudogapping sentence in (53b) is derived by deletion of V' in (54).

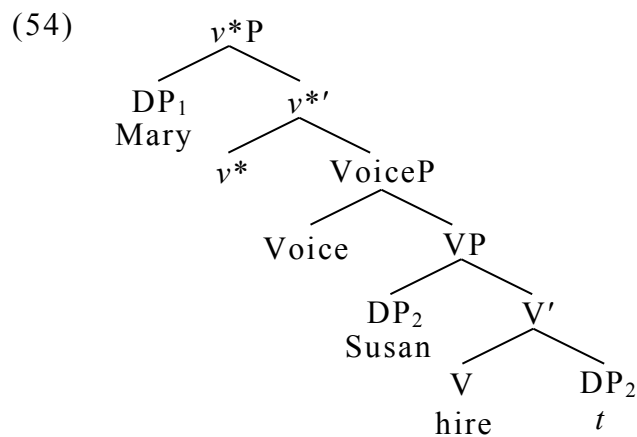

Then, why is the acceptable pseudopassive sentence is not (55b) but (55a)?

- (55) a. Frank talked to Sandra more often than Arthur did to Louise.
 b. *Frank talked to Sandra more often than Arthur did Louise.

If the complement of P can undergo A-movement, as I assume in section 4.4, (55b) seems acceptable at first glance, since the structure of (55) would be as follows in (56):

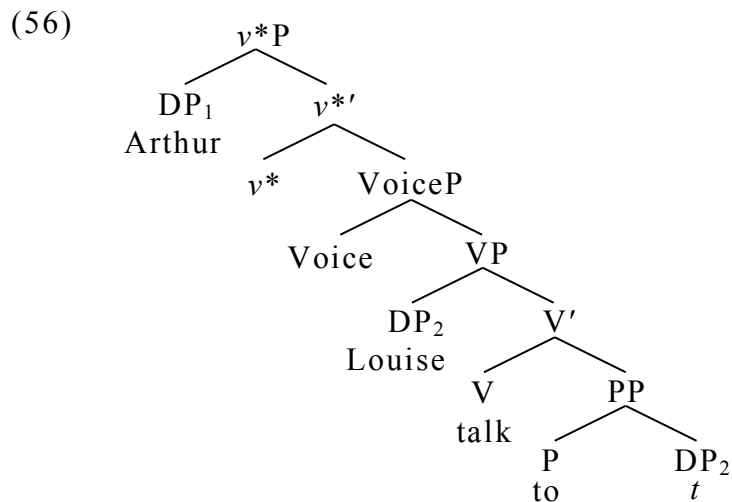

According to Fujita and Matsumoto (2005), however, unergative verbs take a phonetically null object as complement. This object can appear as a cognate object; otherwise, it is incorporated into V and is not pronounced. Adopting Fujita and Matsumoto's analysis, I suggest that unergative verbs are formed by the incorporation of N, and that the EPP-feature on V is satisfied by this incorporation.^{15, 16}

¹⁵ This incorporation is originally assumed in Hale and Keyser (1991).

¹⁶ Oba (2011) observes that unergative verbs take objects other than cognate objects, as in (i), and one might claim that the derivation in (57) is untenable.

- (i) All this time you've been **living a dream**, and now you've seen that dream in the flesh you torment yourself even more. (Oba (2011: 106))

However, I assume that the verb *live* in (i) is a transitive verb, not an unergative verb, because cognate objects must appear with modifiers, as shown in (ii).

- (ii) a. *John lived a life.
b. John lived a happy life.

Thus, (i) is irrelevant to Cognate Object Constructions. Oba also points out that cognate objects can be passivized, as in (iii), which seems to be a counterexample to (57).

- (iii) **All his life was lived** in the sight and sound of Mattie Silver, and he could no longer conceive of its being otherwise. (Oba (2011: 98))

According to Fujita and Matsumoto (2005), however, cognate objects can be

(57)

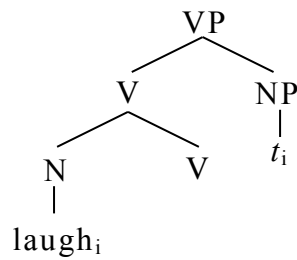

(Hale and Keyser (1991: 56))

This suggestion is supported by the fact that nothing has moved to SPEC-V in the unergative construction, as in (58).

(58) a. John swam beside Bill.

b. *Bill was swum beside by John.

The PP in (58) is adjunct, and *Bill* cannot be extracted. Therefore, the derivation of (48b) is as follows in (59):¹⁷

(59)

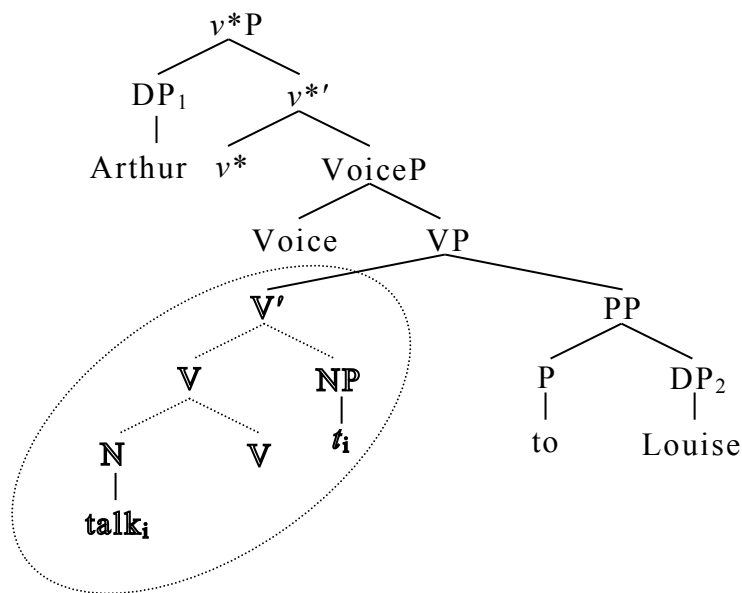

There is no deletion of the string V + P, and this is why the preposition *to*

either DP or NP. DP cognate objects can be passivized, since they are assigned Case in the same way as the internal arguments of transitive verbs. On the other hand, NP cognate objects cannot be passivized because they are incorporated into V.

¹⁷ However, I omit this incorporation hereafter in presenting the syntactic structure of unergative verbs for expository purposes.

must appear in (48b).¹⁸

Fourth, if we dispense with Reanalysis, the conjunction of prepositions in pseudopassives has a natural explanation.

- (60) a. The bridge was flown (both) over and under.
b. Communism was talked, argued, and fought about.
(= (25))

Fifth, it is no wonder that pseudopassivization and P-stranding under \bar{A} -movement occur at the same time, as in (61c).

- (61) a. John talked to Harry about Christianity.
b. Harry_i was talked to t_i about Christianity.
c. What_j was Harry_i talked to t_i about t_j ? (= (27))

The two movements occur independently within our proposal, and the derivation of (61c) is as shown in (62).

¹⁸ The judgment on pseudogapping constructions is controversial. Lasnik (2003) argues that there is a consistent correlation between pseudogapping and pseudopassive, as in (i).

- (i) a. John spoke to Bill and Mary should Susan.
b. Bill was spoken to by John.
(ii) a. John talked about linguistics and Mary will philosophy.
b. Linguistics was talked about by John.
(iii) a. *John swam beside Bill and Mary did Susan.
b. *Bill was swum beside by John.
(iv) a. *John stood near Bill and Mary should Susan.
b. *Bill was stood near by John. (Lasnik (2003: 59))

However, Drummond (2011) claims that most speakers he has asked find (vb) distinctly worse than (va).

- (v) a. Frank called Sandra and Arthur did Louise.
b. *Frank talked to Sandra and Arthur did Louise.
(Drummond (2011: 185))

I tentatively rely on Drummond's judgment in this chapter.

(62)

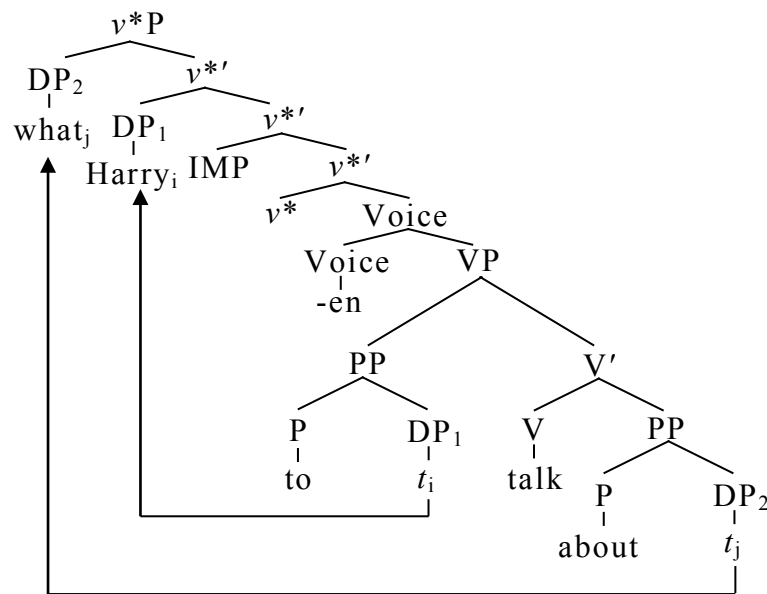

In Chomsky (2008), *wh*-elements are raised to outer SPEC- v^* . The feature that attracts DP_1 is different from the one that attracts DP_2 , and thus there is no violation of the MLC in (61c).

Sixth, if we abandon the filter in (4), the examples in (63) are thus no longer problematic.

- (63) a. Who are_i you t_i suspicious of?
b. What was_j the teacher t_j concerned with?
c. Which client was_k the lawyer t_k uncertain about?

(= (29))

It is no problem to leave the trace that is governed by P. The PPs in (63) are all complements of adjectives. Accordingly, it is possible for the probe outside the PP to access the complement of P. I will explain the restriction on P-stranding under \bar{A} -movement in detail in section 4.6.

Finally, I take up the following examples, where CP appears as a complement, which H&W's analysis cannot explain:

- (64) a. John insisted on your being here on time.

- b. *John insisted on that you be here on time.
- c. John insisted that you be here on time.
- d. That you be here on time was insisted on by John.
- e. *That you be here on time was insisted by John. (=30)

In the traditional grammar, it is assumed that the single verb *insist* takes a *that*-clause as its complement, whereas the complex verb *insist on* takes a DP, but not vice versa. One might assume that the verb *insist* has two lexical entries, as shown in (65).

- (65) a. [+ ____ CP]
 b. [+ ____ [on DP]]

However, this assumption seems redundant and unnecessary if we assume that (64c) is derived by deletion of the string *on it* in (66).¹⁹

- (66) John insisted ~~on it~~ that you be here on time.

There are some examples where the string P + *it* can be elided in English, such as in (67).

- (67) a. I will see (to it) that everything is ready for your departure.
 b. I can't swear (to it) that no one else has ever thought of this.

I assume that there exists a rule that the string P + *it* can be elided because *it* is incorporated into P as I have proposed in (31a), but that there is no rule that deletes either P or *it* independently.

¹⁹ If the string *on it* is not elided, as in (i), it sounds a little awkward and redundant, but it is still acceptable.

(i) ?John insisted on it that you be here on time.

The next question is how (66) is derived. According to Stroik (1996), the movement of the expletive *it* in (68a) is the same phenomenon as that of the ECM subject in (68b), i.e. the movement to SPEC-Agr_O.

- (68) a. I should resent it_i greatly [*t*_i that you did not call]
b. I believe Sue_i quite sincerely [*t*_i to be the best candidate]

(Stroik (1996: 237))

He argues that the expletive *it* is base-generated at SPEC-C, demonstrating the sentences in (69)–(72).

- (69) a. I just knew that Mary would fire John today.
b. I just knew it that Mary would fire John today.
- (70) a. I just knew where Mary would fire John.
b. *I just knew it where Mary would fire John.
- (71) a. I discovered recently that Lou had been fired.
b. I discovered it recently that Lou had been fired.
- (72) a. I discovered recently who had been fired.
b. *I discovered it recently who had been fired. (ibid.: 239)

According to his analysis, the reason for the ungrammaticality of (70b) and (72b) is that both the expletive *it* and the *wh*-phrase occur in SPEC-C, which violates the Doubly Filled Comp Filter. In contrast, the expletive *it* can be compatible with *that*, which is a head.

Stroik proposes the following structure for (68a):²⁰

²⁰ Stroik assumes that V moves to Pred for the Verb-feature checking.

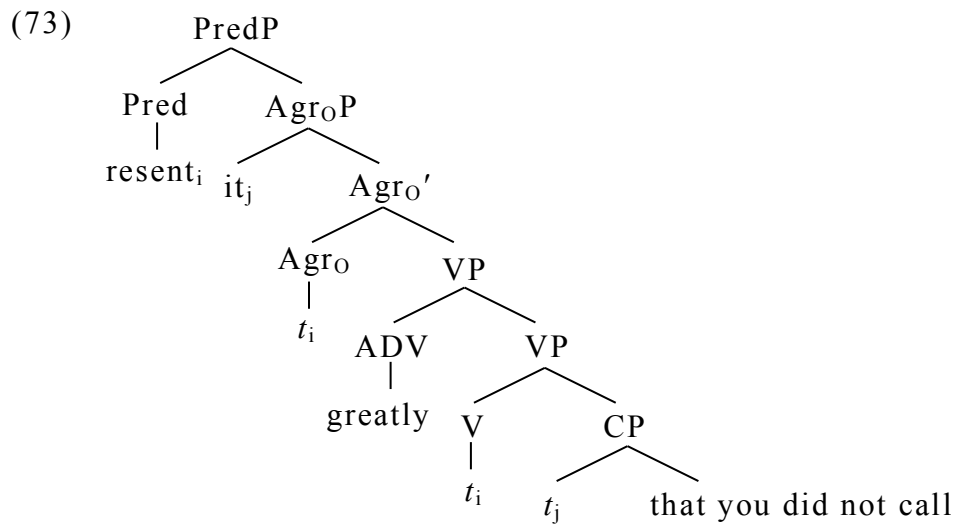

As I have mentioned, we do not assume Agr-projection. Thus, the movement to SPEC-Agr_O corresponds to the movement to SPEC-V, as shown in (74).

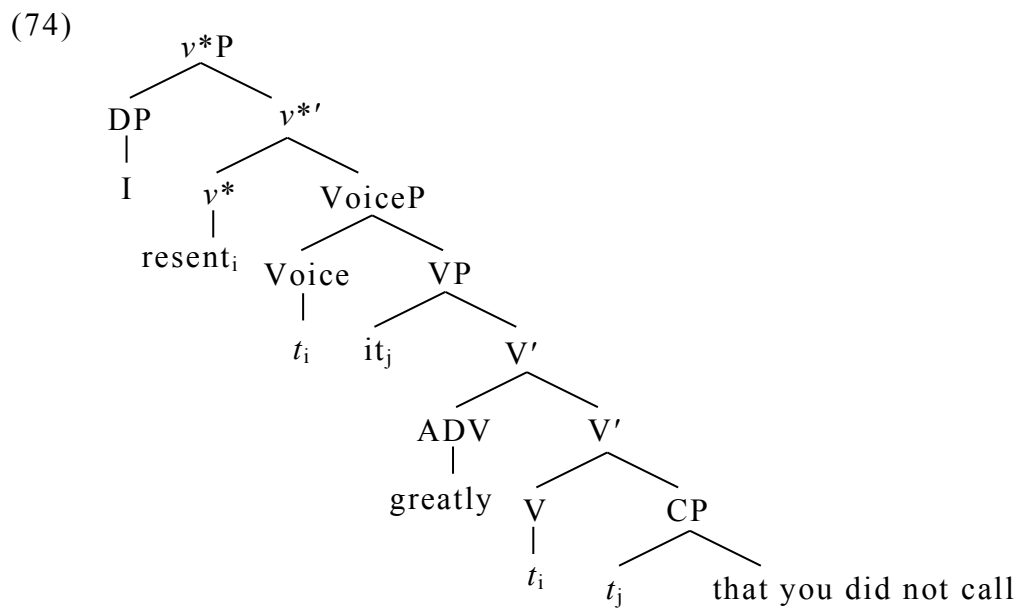

Accordingly, we can assume that the structure of (66) is (75).

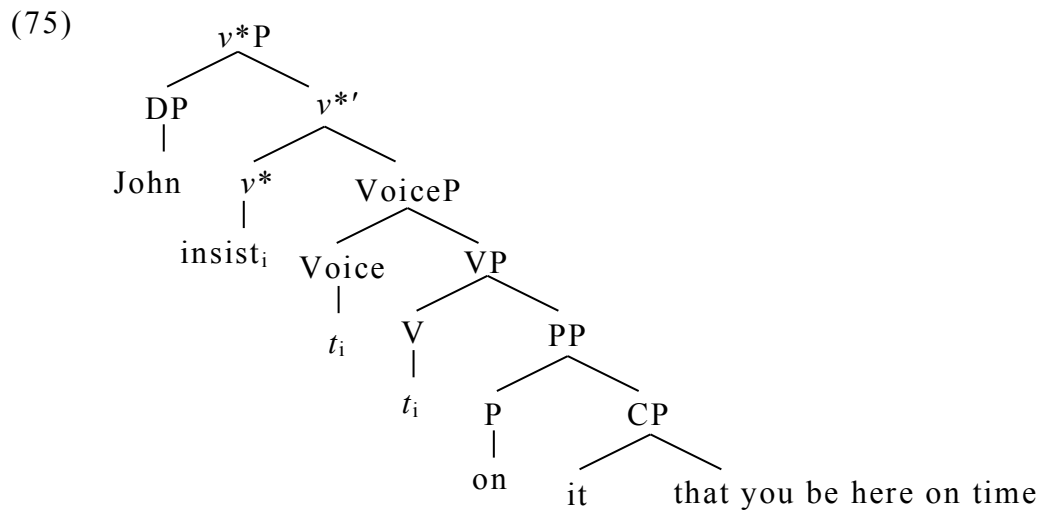

As I have mentioned, the complement of P does not move to SPEC-V, since the EPP-feature on V has already been satisfied by the incorporation of N into V.

Next, let us consider the derivation of (64d). As we have observed, the expletive *it* is generated at SPEC-C. This forces us to answer the question of why (76) is not acceptable, while (64d) is.

(76) a. *It that you be here on time was insisted on by John.

b.

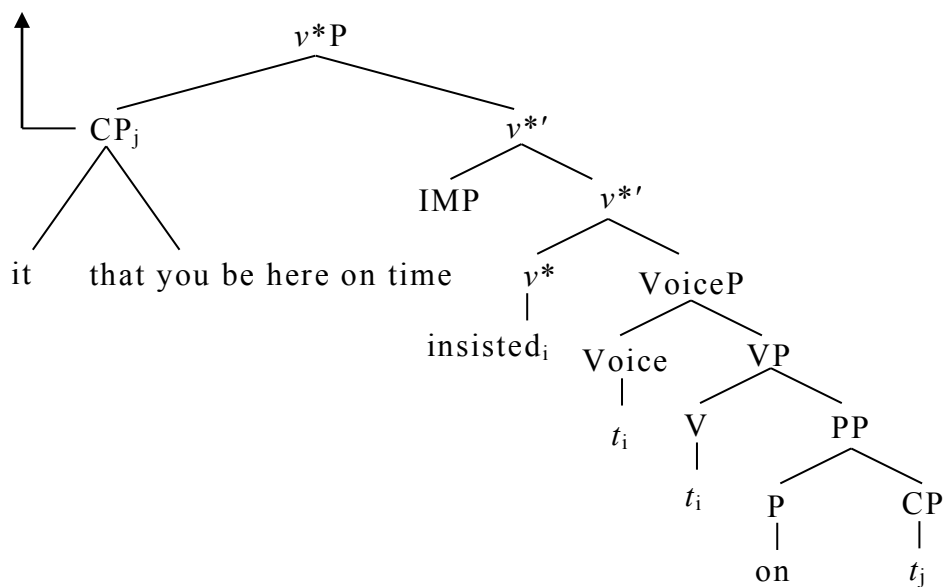

To solve this problem, I partially adopt Emonds' (1976) analysis and assume that CP actually has the structure in (77).²¹

(77) [_{CP} Δ [C' that ...]]

Emonds calls Δ in (77) an *empty node* and proposes that it is deleted or replaced by the expletive *it* through the derivation. Taking this into consideration, I propose (78).

(78) Δ becomes *it* at Spell-Out if it is assigned Case; otherwise, it remains a phonetically null element.

Let us see how this proposal accounts for the ungrammaticality of (76).

Now the structure of (66) corresponds to (79).

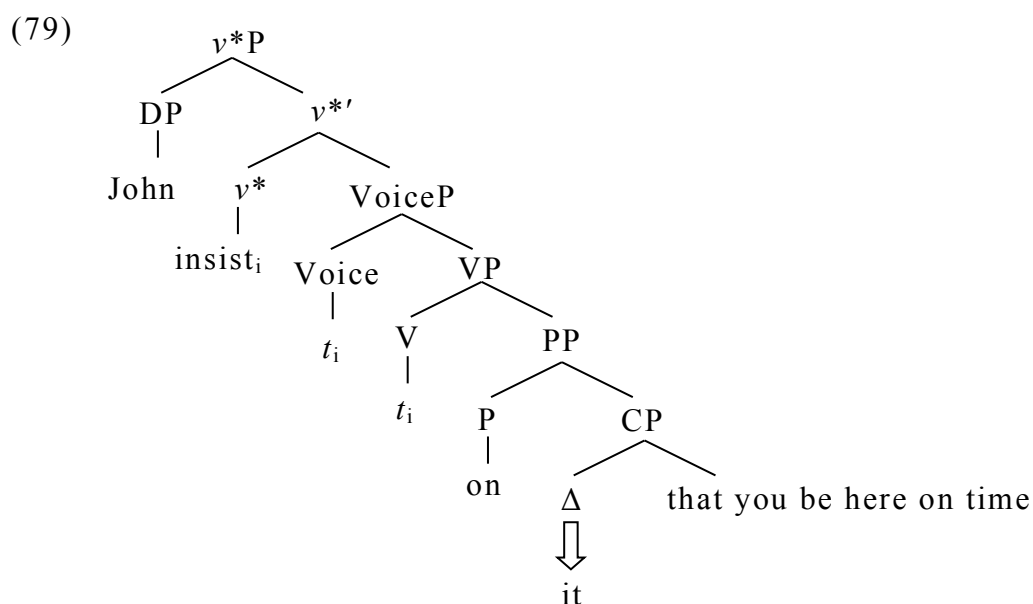

In (79), Δ is adjacent to the preposition *on*. Remember that DP is assigned Case by P when it is adjacent to the P, as I have proposed in (31), which I repeat here as (80).

(80) a. The DP that is adjacent to P at Spell-Out is incorporated into the P.

²¹ I thank Yukio Oba for suggesting me this possibility.

- b. P assigns oblique Case to DP if the DP is incorporated into the P. (= (31))

Consequently, Δ is assigned Case and becomes *it* at Spell-Out. As I have proposed above, the string *on it* can optionally be deleted.

One might claim that this proposal is problematic because the complement CP cannot receive Case in the derivation in (79). However, it is known that CP does not appear in a position of Case assignment, as shown in (81)–(82).

- (81) a. Mary said [e]_i quietly [that she wanted to drive]_i
 b. Paul mentioned [e]_i to Bill [that his shirt was dirty]_i
 c. John knew [e]_i from experience [that the law was unfair]_i

- (82) a. ?*Mary said [that she wanted to drive] quietly
 b. ?*Paul mentioned [that his shirt was dirty] to Bill
 c. ?*John knew [that the law was unfair] from experience

(Stowell (1981: 161))

Stowell (1981) explains this fact by assuming *the Case-Resistance Principle* in (83).

- (83) The Case-Resistance Principle (CRP)

Case may not be assigned to a category bearing a Case-assigning feature. (ibid.: 146)

According to his analysis, since Tense assigns nominative Case, a Tensed clause cannot appear in the object position. He argues that the CP objects move to the VP-adjoined position in (81), where Case is not assigned.

However, this analysis faces an empirical problem. If CP were

actually moved to the VP-adjoined position, there would be no way to explain why it is possible to extract a *wh*-element from the embedded CP, as in (84).

- (84) a. What do you believe [that John bought]?
 b. What did they think [that the burglar stole]?

(Kuwabara and Matsuyama (2001: 25))

Alternatively, if we assume that CP need not be assigned Case, we can conclude that the CPs in (81) stay in situ rather than move to the VP-adjoined position, as shown in (85).²²

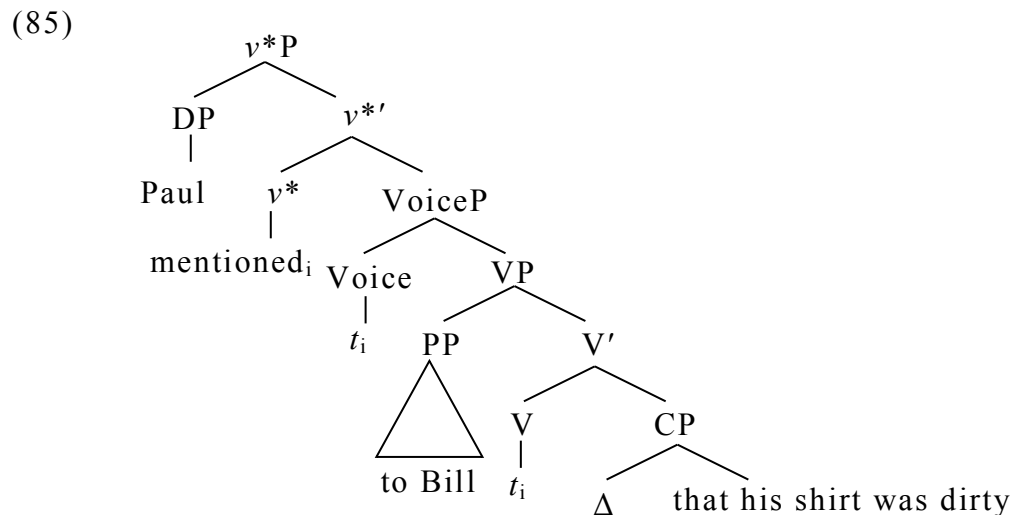

This assumption also accounts for the contrast in (86).

- (86) a. John read the book quickly.
 b. *John read quickly the book.

²² I am not sure what satisfies the EPP requirement of V in (85). On the other hand, if Δ is raised to SPEC-V, sentences like (i) are derived.

(i) I just knew it that Mary would fire John today. (= (69b))
 In (i), Δ agrees with V and is assigned Case, resulting in becoming *it*. Thus, whether the expletive *it* appears in the complement position of V depends on the raising of Δ to SPEC-V.

The complement of V *the book* obligatorily moves to SPEC-V, as in (87), and thus, sentences such as (86b) are never generated.²³

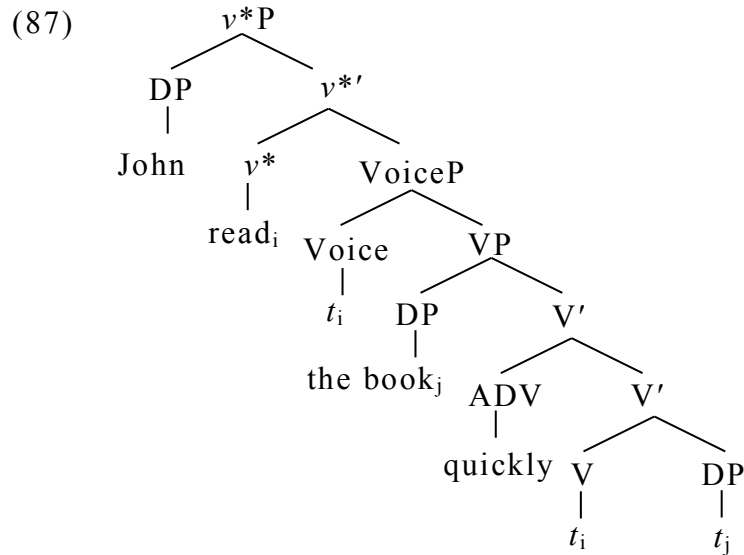

Accordingly, the proposal that CP need not be assigned Case is not problematic.

On the other hand, (64d), the passive counterpart to (66), is derived by the agreement between v^* and CP, as illustrated in (88).

²³ I thank Koji Fujita for pointing this out to me.

(88)

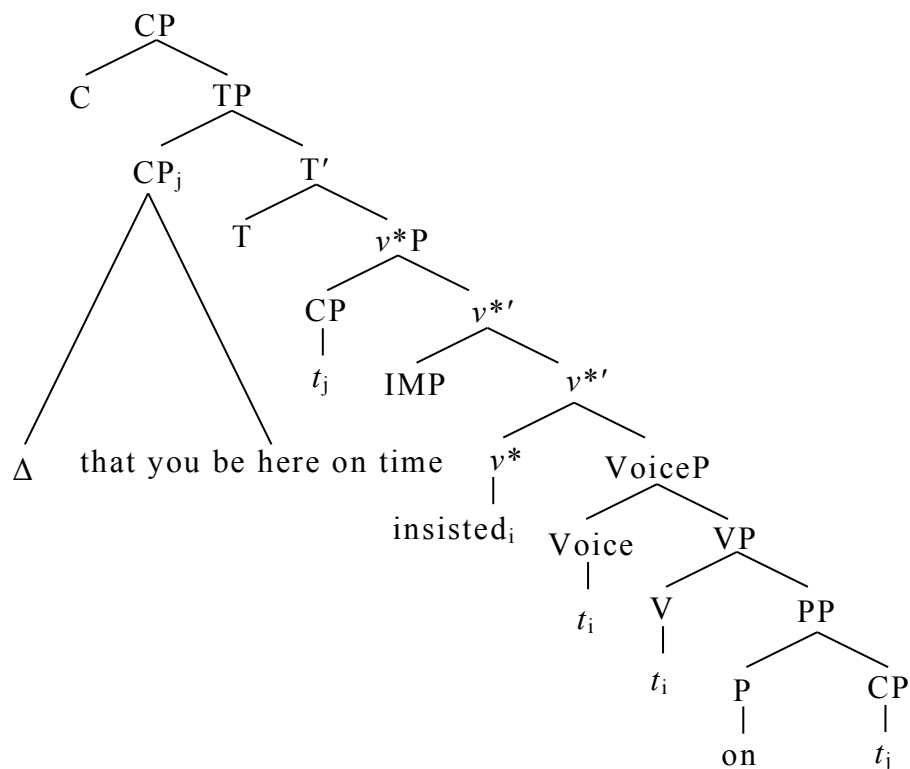

CP at SPEC- v^* then agrees with T. I assume that CPs can appear in Case positions, although they need not be assigned Case.²⁴ As a result, the CP is raised to SPEC-T and receives nominative Case. Note that what agrees with T is not Δ but CP as a whole. Δ *per se* does not agree with T, and it thus remains a phonetically null element. This is why sentences such as (76a) are never generated. In addition, the preposition *on* cannot be elided, as in (64e), since there is no such a string as P + *it* in the derivation in (88).

²⁴ This assumption is based on the fact that CPs can appear as subjects of matrix clauses as well as complements of adjectives. Note that *of*-insertion is required if the complement of adjectives is DP, as in (i).

(i) I am sure *(of) his recovery.

In contrast, CPs appear without *of*, which indicates that CPs do not require any Case value.

(ii) I am sure (*of) that he will recover.

One might wonder whether v^* can agree with Δ instead of CP. I assume that it is possible, and that a sentence like (89a) is derived if such an agreement occurs:²⁵

- (89) a. It was insisted on that you be here on time by John.
 b. *It was insisted that you be here on time by John.

In the derivation of (89a), Δ agrees with v^* and is raised to SPEC- v^* . Then, Δ agrees with T and is raised to SPEC-T, as illustrated in (90).

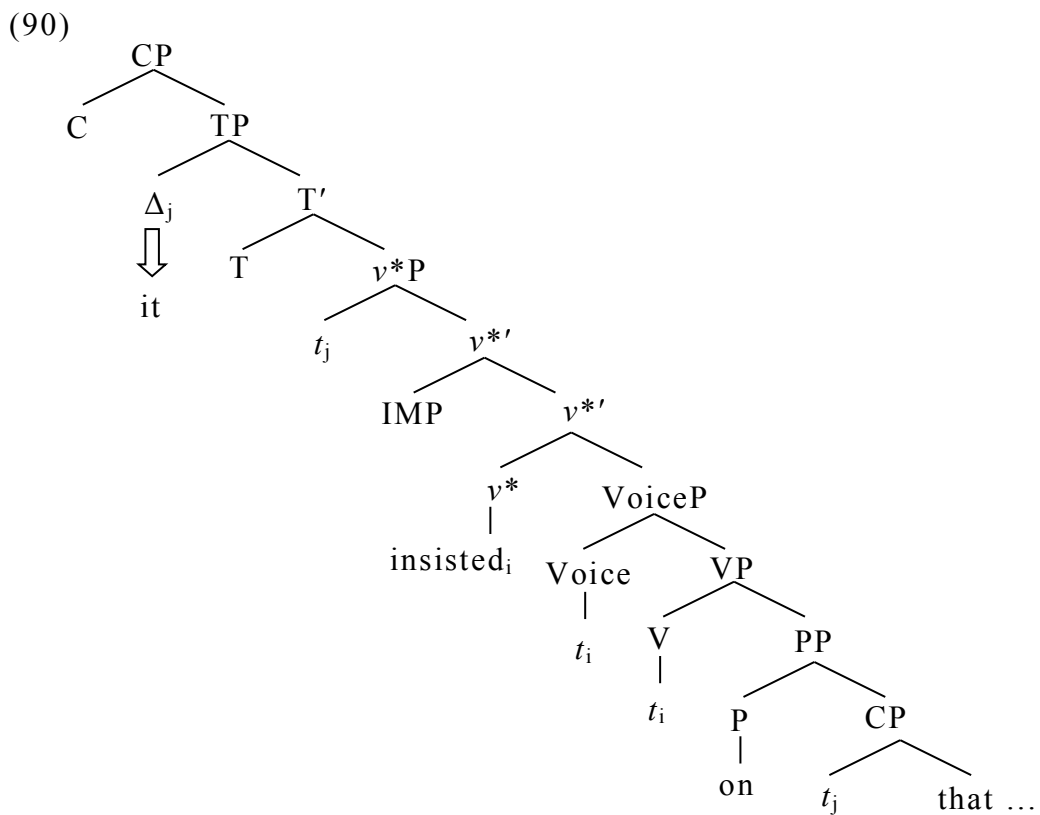

Consequently, Δ is assigned nominative Case and becomes *it* at Spell-Out. Again, there is no such string as P + *it*; hence, the ungrammaticality of (89b), where the preposition *on* is elided independently.

This proposal contradicts CRP, since it prohibits CP from bearing

²⁵ This does not violate the PIC because Δ is at the edge of CP, i.e. SPEC-C. Therefore, Δ is accessible to v^* .

nominative Case. The notion that CP cannot appear in the subject position is based on the examples in (91) that Koster (1978) points out.

- (91) a. *Did that John showed up please you?
b. *What does that he will come prove? (Koster (1978: 53))

To account for these sentences, Koster assumes a phonologically zero NP in the subject position of the main sentence and argues that the CP subject is generated as a satellite sentence binding the NP. This satellite is the sister of S' and the daughter of E (= expression). Since the CP subject is not actually the subject of a sentence, Subject-Auxiliary Inversion is impossible.

However, as Delahunty (1983) points out, Koster's analysis faces some empirical problems such as (92).

- (92) Does that Fred lied to them bother all of the people who
bought stock in his company? (Delahunty (1983: 387))

Although the subject in (92) is a CP, Subject-Auxiliary Inversion is possible. Delahunty claims that the unacceptability of (91) comes from the relative "weights" and prosody of their constituents. In (92), the subject is relatively lighter than the object, and this is why (92) is acceptable. This indicates that the CP can be the subject of a sentence. Therefore, as we have already seen, we do not have to maintain CRP, and the agreement between v^* and CP in the derivation of (64d) is not problematic.

4.6. On P-Stranding under \bar{A} -Movement

As we have observed in section 4.1, P-stranding under A-movement

does not show the same distribution as P-stranding under \bar{A} -Movement.

- (93) a. *The table_i was put the mouse on t_i.
b. What table_i did Harry put the mouse on t_i? (= (11))

The extraction sites are the complement position of P in both sentences, but these sentences undergo different kinds of movements, passivization in (93a) and *wh*-movement in (93b). H&W explain this asymmetry by the notion *semantic words*, but we have already abandoned this notion, Reanalysis and the filter in (4). Thus, these two kinds of movements should be treated as quite different phenomena. As discussed in 4.4.3, the ungrammaticality of (93a) is ascribed to the MLC. On the other hand, it seems to be possible to extract *wh*-elements from almost anywhere. One exception is the extraction from adjuncts.²⁶

- (94) *[What time]_i did John arrive at t_i? (= (3b))

As I claimed in 4.4.3, adjuncts exist on a separate plane, and thus it is impossible to extract *wh*-phrases from adjuncts.

The following is another example of the extraction from adjuncts:

- (95) *Who did you speak to Harry yesterday about? (H&W: 59)

The *about* PP is extraposed to the adjoined position, and (95) is an example of extraction from adjuncts; hence, the ungrammaticality of (95).

Accordingly, we can conclude that whether or not the extraction of a *wh*-phrase from PP is possible in English depends on whether the PP is

²⁶ Of course, we can find some *wh*-movements that violate the MLC, as in (i).

- (i) a. Who did John talk to about what?
b. *What did John talk to whom about?

adjunct or not, and that Reanalysis is irrelevant to this matter.

4.7. Languages That Disallow P-stranding

As we have already seen, English allows P-stranding under A-movement and \bar{A} -movement. English is a rare language in this respect, since both types of P-stranding are impossible in most languages. Then, why do some languages disallow P-stranding?

Drummond, Hornstein and Lasnik (2010) assume that PPs are phases in all languages. They propose that languages differ in whether or not PP has an “escape hatch,” which is essential for intermediate movement to SPEC-P, and that P-stranding is possible only when such an escape hatch exists.

However, if their assumption that PPs are phases in all languages were correct, we could not account for the derivation of pseudopassives. Passivization of the complement of P would always be blocked by the PIC. Thus, at least in the languages where pseudopassivization is possible, PPs must be non-phases.

Then, I propose that in regard to the properties of P, there are three types of language. These are shown in (96).

(96) Three Types of Language

Language Type	A	B	C
P-stranding under A-movement (Pseudopassive)	possible	impossible	impossible
P-stranding under \bar{A} -movement	possible	possible	impossible
Phasehood of PP	non-phase	phase	phase
Escape Hatch		available	not available

English and the Scandinavian languages are classified as Type A, whereas Romance languages are Type C because they permit neither pseudopassivization nor P-stranding under \bar{A} -movement. Icelandic is a Type B language because it allows only P-stranding under \bar{A} -movement.

In Type A languages, the complement of P is accessible to the probe outside the PP. Thus, both pseudopassivization and P-stranding under \bar{A} -movement are possible.

Type B languages do not allow pseudopassives because the complement of P is inaccessible to the outer probe due to the PIC. However, *wh*-phrases can be extracted via the escape hatch, i.e. SPEC-P. Consequently, *wh*-phrases move to SPEC-P first, and then they are attracted by the outer probe, e.g. v^* or C.

In contrast, in Type C languages, PPs do not have this escape hatch. Therefore, they do not permit P-stranding under \bar{A} -movement, let alone

pseudopassivization.²⁷

On the other hand, *wh*-movements with the pied-piping of PPs are possible in perhaps all languages. (97b) is a French counterpart to (97a), and French is a Type C language.

- (97) a. To whom did you speak?
b. À qui as-tu parlé?
to whom have-2SG you spoken

This movement is caused by the percolation of the *wh*-feature to the PP. As a result, the PP has the *wh*-feature, and it is attracted by v^* . In order to deal with this fact, I propose the hypothesis in (98).

- (98) The percolation of the *wh*-feature to PP is optional.

Accordingly, if a *wh*-feature is percolated to PP, *wh*-movement with pied-piping of PP occurs. If there is no such percolation, a sentence with P-stranding under \bar{A} -movement is derived. These two possibilities coexist in Type A languages and Type B languages. In Type C languages, which lack the escape hatch, *wh*-movement always requires the pied-piping of PP because P-stranding under \bar{A} -movement inevitably violates the PIC to probe into the complement of P.

A question that arises now is how the Case value is assigned to the *wh*-phrase when P-stranding under \bar{A} -movement occurs. Before answering this question, let us consider the contrasts in (99)–(100).

- (99) a. Who did you talk to?
b. Whom did you talk to?

²⁷ Even in Type B or C languages, P does not have any Agree-feature, as I have proposed in 4.4.1. P just heads a phase in such languages.

- (100) a. *To who did you talk?
 b. To whom did you talk?

The grammaticality of (99) shows that either *who* or *whom* can appear as the complement of P, but only *whom* is allowed if the pied-piping of PP occurs. Thus, it is mysterious why only (100a) is ungrammatical. Both (99) and (100) are derived from the same structure, as in (101).

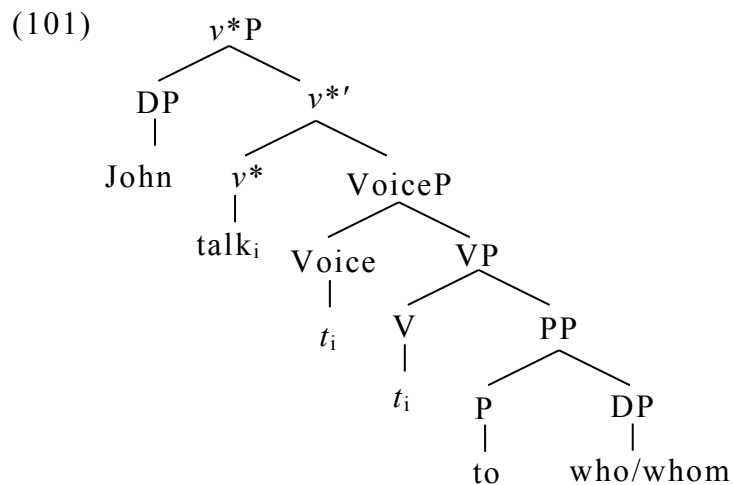

Remember that we have assumed the Case assignment of P as described in (102).

- (102) a. The DP that is adjacent to P at Spell-Out is incorporated into the P.
 b. P assigns oblique Case to DP if the DP is incorporated into the P. (= (31))

Note that the complement of P in (101) is in the v^*P phase domain, where V c-commands the complement of P. As I have proposed, V, which inherits the Agree-feature of v^* , agrees with a phonetically null cognate object. However, if the Multiple Agree of V occurs, there remains the

possibility that the complement of P can also agree with V.²⁸ I suggest that a *wh*-phrase agrees with the Agree-feature on V and is assigned accusative Case when it strands P. If the percolation of the *wh*-feature to PP does not occur, only the *wh*-phrase is raised to SPEC-*v**, and thus it is not adjacent to P. Accordingly, the *wh*-phrases in (99) are unable to receive Case from P but are assigned accusative Case by V.²⁹ On the other hand, if the percolation of the *wh*-feature to PP does occur, PP as a whole is raised to SPEC-*v**, where the *wh*-phrase is incorporated into P and is assigned oblique Case. In this case, I assume that the Multiple Agree of V is not triggered or the accusative Case is “rewritten” as the oblique Case by the incorporation into P. This causes the pied-piping of PP. Therefore, the Case of *wh*-phrases in (100) is oblique Case.

To account for the asymmetry in (100), I propose the declension of *who*, as shown in (103).

(103) The Declension of *who*

Nominative Form	<i>who</i>
Accusative Form	<i>who</i> / <i>whom</i>
Oblique Form	<i>whom</i>

In accusative form, *who* and *whom* coexist. In contrast, *whom* is the sole oblique form. This is why (100a) is ungrammatical because the

²⁸ I assume that the Multiple Agree of V is optional because V can agree with at least one argument, i.e. a cognate object, without the agreement with the complement of P.

²⁹ The *wh*-phrase agrees with the Agree-feature on V and the edge-feature on *v** simultaneously.

Case of the *wh*-phrase must be oblique.³⁰ Moreover, the asymmetry in (100) supports the assumption in (102) about the Case assignment of P.

4.8. Conclusion

In this chapter, I have demonstrated that P-stranding phenomena can be explained without resorting to Reanalysis, to which there are counterexamples. Additionally, we have seen that pseudopassive sentences are sometimes confused with peculiar passives in the literature, but the latter passive is not derived under A-movement. It is necessary to distinguish two types of prepositional passive in order to discuss the derivation of pseudopassives.

I have proposed that P assigns Case to DP in a different way from *v** or C. We have observed that this proposal can account for the counterexamples to H&W. In addition, this proposal correctly predicts the asymmetry in (100).

Following Stroik (1996) and Emonds (1976), I have suggested (77) and (78) so as to account for the pseudopassivization of complement CP.

Furthermore, I have suggested that there are at least three types of language with regard to the properties of P. This explains why some languages allow P-stranding but others do not, and why some languages

³⁰ One might claim that the unacceptability of (100a) is a phonological phenomenon, i.e., there is a rule that *whom* can be pronounced as *who* when it appears in the sentence-initial position. However, this is not the case. Although the complement *wh*-phrase of P is not at the sentence-initial position in (ia), it can be pronounced as *who*.

- (i) a. I know the man who/whom you spoke to yesterday.
- b. I know the man to *who/whom you spoke yesterday.

permit both pseudopassivization and P-stranding under \bar{A} -movement while others allow only the latter.

I have presented some evidence against Reanalysis and have accounted for P-stranding under the assumption about the Case assignment of P in (102).

CHAPTER FIVE

ON THE PASSIVIZABILITY OF PERCEPTION AND CAUSATIVE VERBS¹

5.1. Introduction

In this chapter, I will discuss the long-standing riddle of why perception and causative verbs cannot be passivized, even though they seem to be transitive verbs. These verbs are known to take bare infinitives for complements in the active voice, as in (1).

- (1) a. John saw her leave.
b. John made her run.

The accusative morphology in (1) indicates that the matrix verbs assign accusative Case to the embedded subjects. However, in contrast to ECM verbs, as in (2), the passive counterpart to (1) is unacceptable, as illustrated in (3).

- (2) a. John believes her to win the race.
b. She is believed to win the race.
(3) a. *She was seen leave.
b. *She was made run.

¹ Earlier versions of this study were presented at the 35th Annual Meeting of the Kansai Linguistic Society, held at Kyoto University of Foreign Studies in June 2010, and were subsequently published as Honda (2011). I am indebted to Yukio Oba, Sadayuki Okada, Koji Fujita, and the audience at the meeting for their invaluable comments and suggestions. I also would like to thank the informants at the University of Connecticut for judging my English data, and I am grateful to Koji Shimamura for asking them. Needless to say, all remaining inadequacies are mine.

On the other hand, it has been assumed that the acceptable passive counterpart takes *to*-infinitives as complements, as shown in (4).

- (4) a. She was seen to leave.
b. She was made to run.

Yet, there is no active counterpart to (4).

- (5) a. *John saw her to leave.
b. *John made her to run.

Therefore, the behavior of perception and causative verbs seems quite mysterious. If the matrix verbs assign accusative Case to the embedded subjects in the same way ECM verbs do, we cannot account for why the embedded subjects cannot be passivized, as in (3). On the other hand, given that sentences like (4) are acceptable passive sentences, we do not understand why there is no active counterpart like (5).

The aim of this chapter is to clarify the reason why it is impossible to derive sentences like (3). Additionally, I discuss sentences like (4).

The organization of this chapter is as follows. In section 5.2, I review three major previous analyses, Hornstein et al. (2008), Felser (1998), and Basilico (2003). The first one assumes that both (1) and (4) are derived from the same base structure, while the others argue that there is no active-passive relation between these two sentences. I discuss these three approaches and point out some of their problems. In section 5.3, I propose the syntactic structure for (1), which is based on Basilico's (2003) analysis. Section 5.4 discusses the derivation of sentences like (4). I propose that sentences like (4) have the similar structure as sentences with *wager*-class verbs. Section 5.5 presents the

conclusion of this chapter.

5.2. Previous Analyses

5.2.1.1. Review of Hornstein et al. (2008)

Hornstein et al. (2008) argue that the complement of perception verbs is TP, adopting Chomsky's (2001) maximization principle that claims partial elimination of features under Match, followed by elimination of the residue under more remote Match, is not an option.

First, they distinguish (6a)/(7b), on the one hand, and (8b)/(9b), on the other.

- (6) a. John saw/heard/made them hit Fred.
b. *John saw/heard/made them to hit Fred.
- (7) a. *They were seen/heard/made hit Fred.
b. They were seen/heard/made to hit Fred.

(Hornstein et al. (2008: 198))

- (8) a. *I saw John know French.
b. John was seen to know French.
- (9) a. *I heard John have an accent.
b. John was heard to have an accent. (ibid.: 200)

According to their analysis, perception verbs (and causative verbs) select eventive predicates as complements. For this reason, (8a) and (9a) are unacceptable because the complements are propositions. On the other hand, their passive counterparts are acceptable, as in (8b) and (9b). They claim that these sentences have an epistemic reading that can be paraphrased roughly as in (10).

- (10) a. It was known that John knew French.
b. It was known that John had an accent.

(Hornstein et al. (2008: 200))

Given that the eventive reading is associated with TP, i.e. a bare infinitive, while the propositional/epistemic reading is associated with CP, i.e. *to*-infinitival, the complements in (8b) and (9b) are CPs. This indicates that (6a) and (7b) have a different structure from (8b) and (9b). Accordingly, the active counterparts to (8b) and (9b) actually correspond to (11a) and (11b), respectively.

- (11) a. *I saw John to know French.
b. *I heard John to have an accent. (ibid.: 201)

Hornstein et al. argue that the contrast between (11a) and (8b) or between (11b) and (9b) can be reduced to that between (12a) and (12b).

- (12) a. *John wagered Peter to be crazy.
b. Peter was wagered to be crazy. (ibid.)

Wager-class verbs take propositions as complements and allow the passivization of embedded subjects even though they cannot assign Case to these subjects in the active. The ungrammaticality of (11) and (12a) is attributed to the Case-assigning ability of the verbs. Therefore, we can conclude that (8) and (9) are not examples of perception verbs, as in (6) and (7).

Hornstein et al. then assume that both infinitives and past participles are “nominal” projections in the sense that they are associated with Case and ϕ -features. They argue that the infinitival complement of perception and causative verbs in English is inflected in number and

Case, given Raposo's (1987) observation that Portuguese infinitival clauses can only appear in positions where Case can be licensed, as in (13).

- (13) a. O rapaz receia [chumbar o exame].
the boy fears fail-Infl the exam
'The boy fears failing the exam.'
- b. o receio *(de) [chumbar o exame]
the fear of fail-Infl the exam
'the fear of failing the exam'
- c. O rapaz está receoso *(de) [chumbar o exame].
the boy is fearful of fail-Infl the exam
'The boy is fearful of failing the exam.'

(Hornstein et al. (2008: 203–204))

Infinitival clauses can be Case-marked when they are the complements of verbs, as in (13a). In contrast, when they appear as the complements of nouns or adjectives as in (13b) or (13c), the insertion of the dummy preposition *de* 'of' is required for Case-marking. This shows that infinitival clauses in Portuguese must be assigned Case.

Hornstein et al. suggest that the same analysis can be applied to English infinitival clauses, which also require Case assignment.² In addition, they assume that the infinitival T has an uninterpretable Case feature and a set of ϕ -features, which are necessary for its Case valuation

² The analysis in Hornstein et al. takes into account that before the phonological weakening of the infinitive's inflectional endings, English also had an overt infinitival morpheme.

under ϕ -checking. Considering that the infinitival T cannot assign Case to the embedded subject, they also assume that the ϕ -set of the infinitival T involves only number, which is [-interpretable].³

Accordingly, the derivation of the infinitival complement of (14) is (15).

(14) I saw Mary leave.

(15) a.

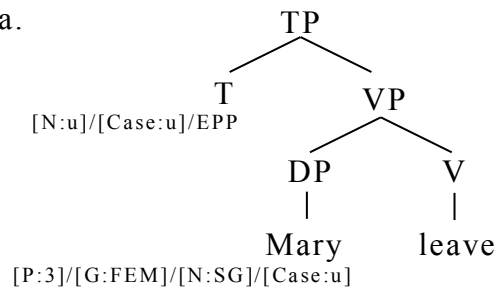

b.

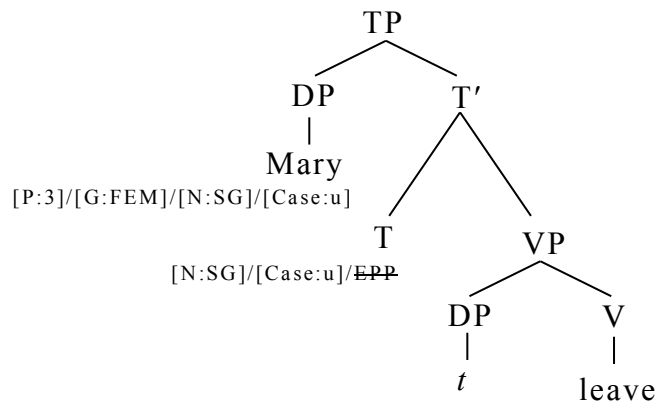

As we see in (15b), the infinitival T agrees with the embedded subject *Mary*, which values the number feature of the infinitival T and satisfies the EPP. The infinitival T cannot assign Case to *Mary* because the infinitival T does not have a [-interpretable] person feature. Then, the light verb *v* is merged as in (16).

³ Hornstein et al. argue that there is no evidence that a gender feature may be associated with T in either European Portuguese or English, and that if the infinitival T had a person feature, it could value the Case feature of the embedded subject under Chomsky's (2000, 2001) system.

(16)

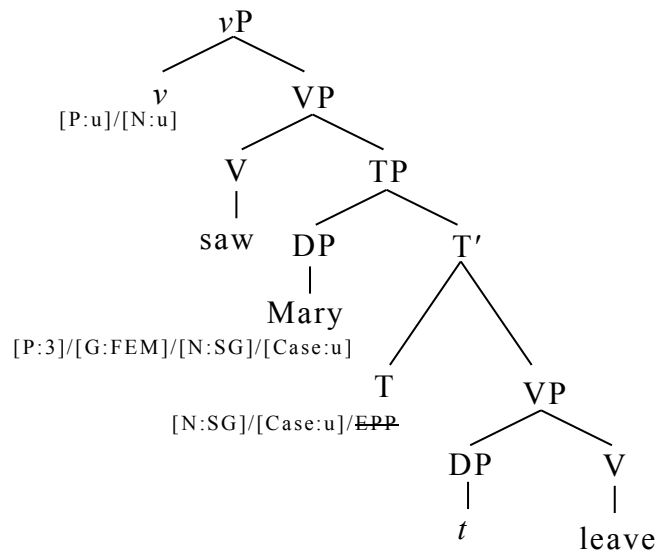

In (16), the infinitival T and the embedded subject *Mary* are equidistant from the light verb *v*, which indicates that either element can agree with *v*. If the light verb *v* agrees with *Mary* first, the number feature and the person feature of *v* are both valued. Then, T cannot agree with *v*, since *v* has no unvalued feature under the maximization principle. As a result, the Case feature of T remains unvalued, which causes the derivation to crash. Alternatively, if *v* agrees with the infinitival T first, the Case feature of T is valued with the person feature of *v* unvalued, as in (17).

(17)

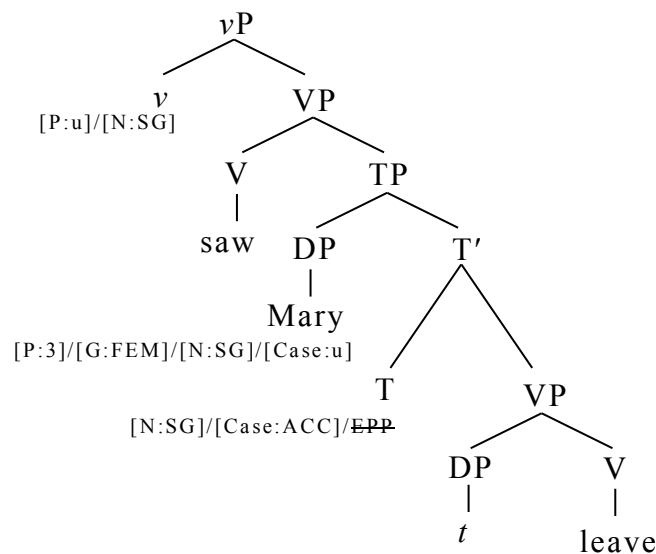

In (17), *v* remains active and then agrees with *Mary*, which values the person feature of *v* and the Case feature of *Mary*. Consequently, all the features in the derivation are valued, and the derivation converges.

Next, let us consider the passive counterpart. Hornstein et al. assume that passive sentences are derived when VP is selected by the participial head *-en* instead of the light verb *v*. They argue that the participial head has unvalued gender, number, and Case features. Accordingly, the passive of a perception verb has the following structure:

(18)

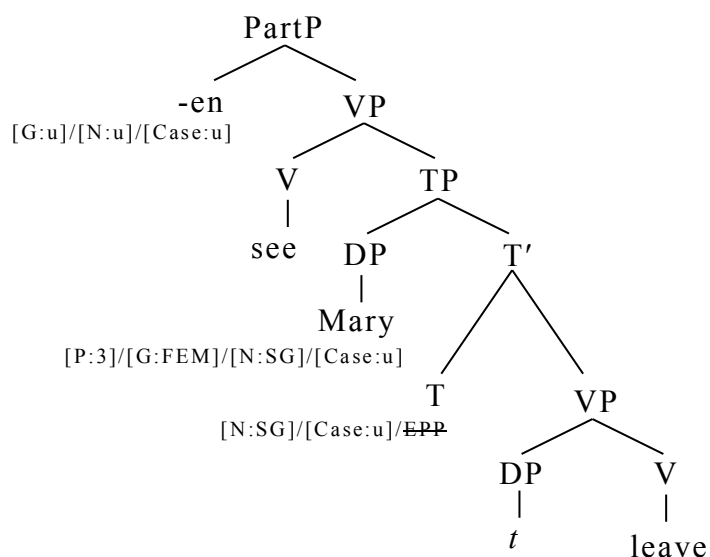

In (18), agreement between the participial head *-en* and the embedded subject *Mary* values the gender and number features of *-en*. Further computations then introduce a finite T into the structure, which can value Case features, as shown below:

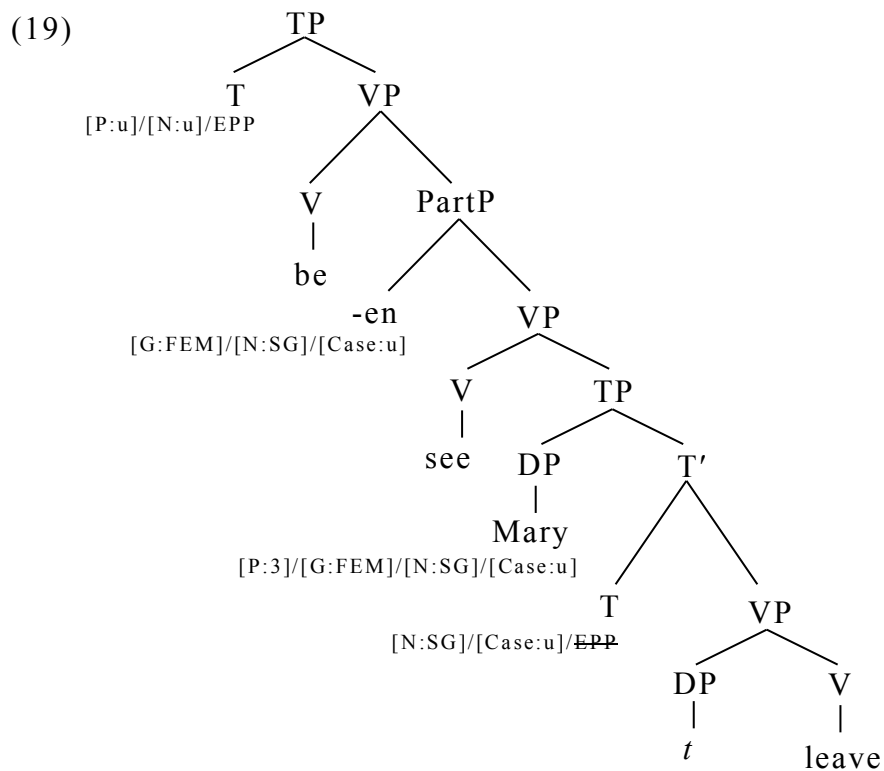

There are three elements that have an unvalued Case feature in (19); the participial head *-en*, the infinitival T and the embedded subject *Mary*. These three elements must agree with the finite T in order to value the unvalued Case feature. Note that *-en* and the infinitival T are not equidistant from the finite T. It is *-en* that is closer to the finite T. Compared with *-en*, the infinitival T has fewer features that can agree with the finite T. The participial head *-en* has the gender feature, the number feature and the Case feature, while the infinitival T lacks the gender feature. On the other hand, the embedded subject has the person feature in addition to the features that *-en* has. Under the maximization principle, *-en* does not intervene between the finite T and the embedded subject *Mary*. Therefore, the finite T agrees with *-en* first and then agrees with *Mary*. However, *-en* does intervene between the finite T and the infinitival T. As a result, the Case feature of the infinitival T

remains unvalued, which is why a passive sentence like (20) is not grammatical.

(20) *Mary was seen leave.

Now, let us consider how the grammatical passive of perception verbs like (21) is derived.

(21) Mary was seen to leave.

It is a mystery why *to* is inserted in (21). According to Hornstein et al., this *to*-insertion process is reminiscent of the *of*-insertion rule, as shown in (22).

- (22) a. *the destruction the city
b. the destruction of the city

The preposition *of* in (22b) is the morphological realization of the inherent Case assigned by the nominal *destruction* to its complement (Chomsky (1986)). This *of*-insertion rule is known as a Last Resort repair strategy to circumvent the Case Filter violation. Hornstein et al. claim that the preposition *to* in (21) is the realization of the inherent Case assigned by the matrix verb to its infinitival complement.

Furthermore, they argue that perception verbs can assign the inherent Case either in the active or the passive, but the economy principle excludes sentences like (23) because the *to*-insertion is a Last Resort strategy.

(23) *I saw Mary to leave.

5.2.1.2. Examination of Hornstein et al. (2008)

Hornstein et al. elegantly explain the grammaticality of the

active-passive pair of perception verbs, but their analysis holds some empirical problems.

Their analysis emerges from the notion that both the active and passive of perception verbs are derived from the same base structure. If this analysis were correct, we could not predict the fact that agentive perception verbs like *watch*, which also take bare infinitival complements, do not passivize, as shown in (24).

- (24) a. We watched John draw a circle.
b. *John was watched (to) draw a circle. (Felser (1999: 31))

Even if they assume another structure for this class of verbs, there remains another problem with this analysis. Perception verbs can be followed by clausal idioms, as illustrated below:

- (25) a. I saw the shit hit the fan. (Ushie (1995: 294))
b. *The shit was seen to hit the fan. (ibid.: 301)

However, as we see in (25b), clausal idioms cannot appear in passive forms of perception verbs. If both sentences in (25) are derived from the same base structure, the unacceptability of (25b) is mysterious.

Considering these facts, we can conclude that the active and passive forms of perception and causative verbs must be derived from different structures, contrary to the analysis presented in Hornstein et al. (2008).

5.2.2.1. Review of Felser (1998)

Felser (1998) considers why the complement of perception verbs lacks some of the projections illustrated in (26), which is the basic structure of a full English sentence in the early Minimalist Program

framework.

(26) [CP C [AgrSP AgrS [TP T [AgrOP AgrO [VP ... V ...]]]]]

First, Felser argues that at least AgrO is projected above VP in the complement of a perception verb that contains a transitive verb; otherwise, the object in the embedded clause could not be checked its Case. Moreover, she assumes that the verb in the embedded clause is raised to a head higher than AgrO, taking up (27) as an example.

- (27) a. We saw Mikey look(ing) the reference up.
b. We heard Betsy throw(ing) the bicycle out.

(Felser (1998: 357))

According to Johnson (1991), the verb and its particle become separated when the verb moves to some higher head position, leaving the particle behind. In addition, as Guasti's (1993) floating quantifier example in (28) shows, the object of the embedded clause is overtly raised to SPEC-AgrO.⁴

- (28) I saw the children all leave.

Since the direct objects in the embedded clauses are overtly raised to

⁴ As Basilico (2003) points out, the appearance of floating quantifiers is not always evidence of movement. The following examples are cases in point:

- (i) a. *The children were seen all.
b. *The ice cubes froze all.
c. The children were all seen.
d. The ice cubes all froze. (Basilico (2003: 31))

If the subject of such sentences starts out in the object position and then is raised to the subject position, (ia) and (ib) would be grammatical. Instead, the quantifier is required to appear preverbally, as in (ic) and (id). Furthermore, there is no position to which the subject *the children* in (ii) could move.

- (ii) The children all are sleeping. (ibid.: 32)

SPEC-AgrO, the verbs *look* and *throw* must be raised to a higher head than AgrO in (27).

Second, Felser points out that perception complements are not specified for tense. These complements do not permit aspectual *have* or stative predicates, as in (29)

- (29) a. *We saw them have/having repainted the house.
 b. *We saw her be(ing) tall. (Felser (1998: 358))

Alternatively, Felser analyzes the complements of perception verbs as projections of an aspectual head, which she calls AspPs. She assumes that Asp is located between T and V, as illustrated below:

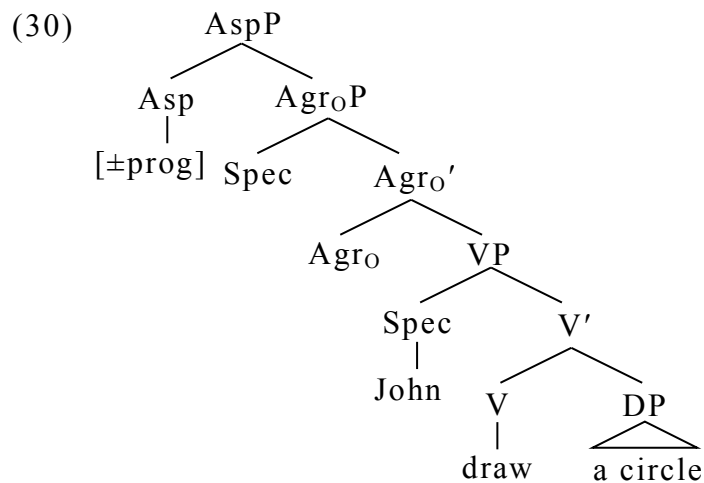

(ibid.: 360)

Furthermore, manner adverbs, but not temporal adverbs, may appear in the complement clauses, as in (31).

- (31) We saw him look frequently/*often at the wall. (ibid.: 361)

This indicates that there is a head movement of the verb in the complement clause to Asp, since manner adverbs are VP adjuncts.

Felser claims that one of the most important properties of complements of perception verbs is that they exclude stative predicates.

The non-finite clausal complement of a perception verb must contain a stage-level predicate. Individual-level predicates are unable to appear in the complement of perception verbs, as in (32).

- (32) a. *We saw John have a car.
b. *We saw Mary be tall. (Felser (1998: 361))

Kratzer (1995) argues that only stage-level predicates provide an event argument, which must be assigned to a syntactic position. According to Kratzer, all arguments but the highest argument are realized within the lexical projection of the predicate, and the external argument of individual-level predicates is generated in SPEC-Infl. Felser adopts this notion, suggesting that event arguments are generated in SPEC-Asp and individual-level predicates fail to project AspP. This means that only stage-level predicates project AspP, and the event argument is a true external argument because it is an argument of the entire VP. Thus, the structure for stage-level predicates is as follows:

- (33) [_{AspP} e [_{Asp'} Asp [_{VP} DP [_{V'} V ...]]]] (ibid.: 369)

Note that Asp contains the grammatical feature [\pm prog], which is spelled out as *-ing* in English if it is valued [+prog]. The proposal that individual-level predicates do not project Asp is consistent with the fact that individual-expressions cannot appear in the progressive. Since perception verbs select only Asp for a complement, individual-predicates never appear in the complement clause of perception verbs.

The other important notion about perception complements is that the time interval taken up by the event described by a perception verb complement includes the time interval taken up by the matrix event,

which Felser calls *the Simultaneity Condition*. Following Rizzi's (1986) notion that an empty category requires an index, Felser assumes that the event argument must be assigned a temporal index by T. Recall that T is not projected in the complement of perception verbs. Thus, a single T needs to be linked to two distinct event arguments, which is consistent with the Simultaneity Condition. In order to support this, Felser proposes the following hypothesis:

(34) Event Control Hypothesis

In direct perception constructions, the perception verb functions as a control predicate in that its event argument controls the event argument provided by the embedded predicate. (Felser (1998: 370))

Felser assumes that *e*-PRO functions as the event argument in the embedded clause, which is controlled by the event argument in the matrix clause. Therefore, the syntactic structure for perception verbs corresponds to (35), where Agr-projections have been omitted for expository purposes.

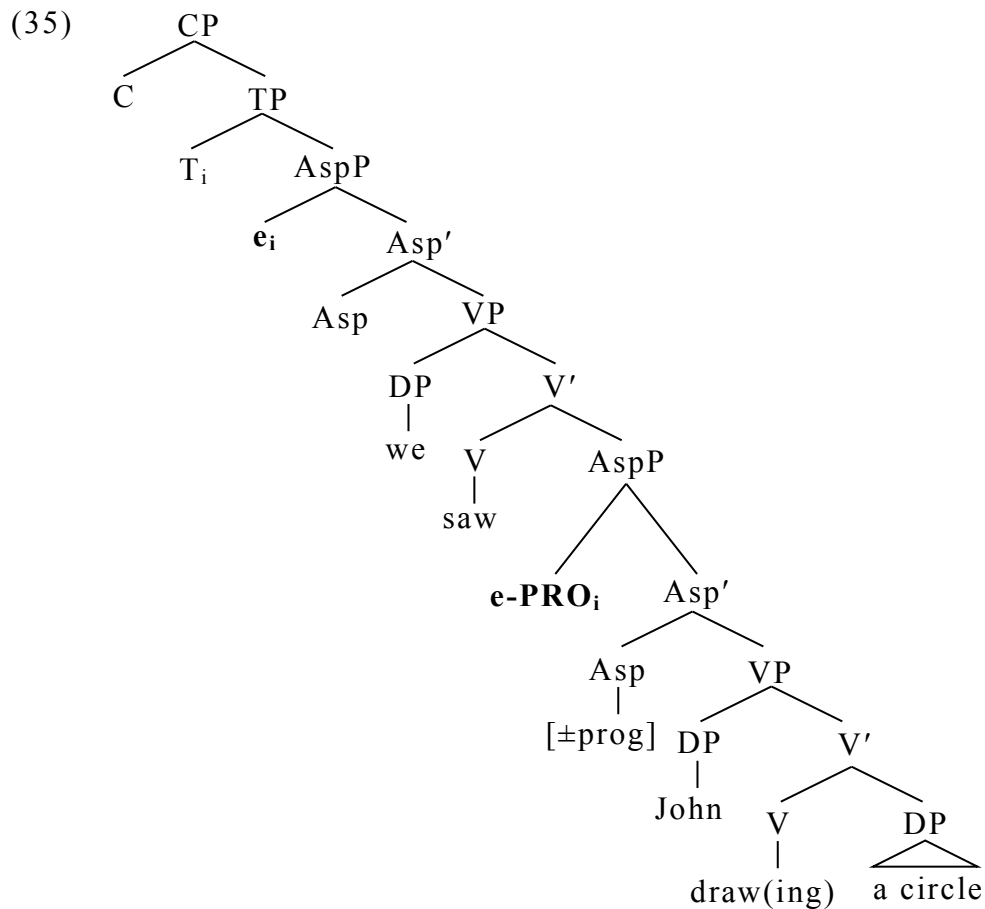

(Felser (1998: 371))

Given this structure, Felser suggests that passive participles fail to provide an event place, and that no event control relation between the matrix clause and the complement clause can be established. She claims that this is the reason why a sentence like (36) is unacceptable.

(36) *John was seen draw a circle. (ibid.: 379)

In this vein, the unacceptability of (36) is analogous to that of constructions involving obligatorily-controlled PRO, as in (37b).

- (37) a. Mary_i promised John PRO_i to leave.
 b. *John_k was promised *t_k* PRO to leave (by Mary_i).
 c. We *e_i* saw John *e-PRO_i* draw a circle.
 d. *John_k was seen *t_k* *e-PRO* draw a circle. (ibid.: 380)

Furthermore, Felser assumes that inserting infinitival *to* rescues passives like (36).

- (38) a. John_i was seen *t_i* to draw a circle.
b. *We saw John to draw a circle. (Felser (1998: 380))

According to Felser, *to*-infinitives are full IPs, and no direct perception is involved in that case. Thus, the event argument of the complement clause can be locally bound by *to* in (38a). On the other hand, since adding the infinitival marker is the only way to rescue sentences like (36), sentences like (38b) are ruled out because insertion of *to* blocks event control.

Finally, Felser's analysis can predict the restrictions on bare plurals in perception constructions. Bare plural subjects like *dinosaurs* in (39a) are ambiguous because they have existential and generic readings.

- (39) a. Dinosaurs ate kelp. ⇒EX/GEN
b. We saw dinosaurs eat(ing) kelp. ⇒EX/*GEN (ibid.)

In order for bare plural subjects to have a generic reading, they must occupy SPEC-T. Since perception complements do not project TP, it is impossible for the bare plural subjects in the complement of perception verbs to have generic readings.

5.2.2.2. Examination of Felser (1998)

Felser's analysis is advantageous because it can correctly account for the simultaneity between the events of the matrix clause and the complement clause; however, it faces some technical and empirical problems.

First, as Basilico (2003) points out, two questions remain about Felser's analysis: (i) Is there really a control relation between the events of the matrix clause and the complement clause? (ii) Is it true that passives lack an event argument?

Basilico argues that the simultaneity of the events does not necessarily mean that the subordinate event argument is controlled by and coindexed with the matrix event argument. When two arguments are coindexed, they must be identical in reference. Thus, if Felser's analysis were correct, the event in the matrix clause and the event in the embedded clause should be identical. Events are associated with locations in space and time. Thus, the location of the matrix event and the subordinate event must be identical. However, the locations of the two events are clearly different in the following example:

- (40) While sitting in my office, I saw the car hit the pedestrian in
the street. (Basilico (2003: 21))

In addition, Basilico points out that Felser does not give independent evidence for the claim that passives lack an event argument. This claim is crucial for her explanation of the unacceptability of sentences like (36). If passives lacked an event argument, they would behave like individual-level predicates. However, they are different since individual-level predicates do not appear in existential sentences, as in (41a).

- (41) a. *There are linguists tall.
b. There were warning issued to the residents. (ibid.)

While individual-level predicates are not tied to a particular time and

place, passives are clearly eventive. Therefore, the proposal that passives do not project an event argument is untenable.

Moreover, even if the claim that passives do not project an event argument is correct, we cannot account for why the event argument of the complement clause cannot be assigned a temporal index. According to Felser, in order for the matrix T to bind the event argument of the subordinate clause in the active, the matrix T must simultaneously bind both event positions, as in (42).

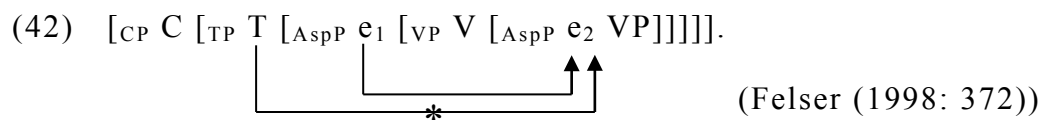

In (42), however, the multiple binding by the matrix T is blocked by the presence of the coindexed c-commanding event argument contained in the higher verb. Then, let us consider the binding relation in the passive. Although Felser does not explicitly present the syntactic structure for the passive of perception verbs, it would be as follows:

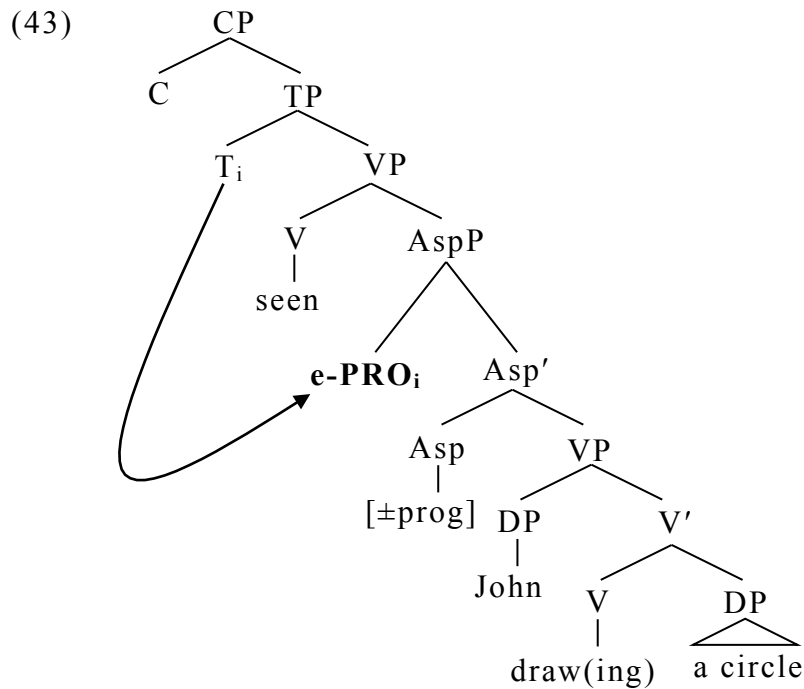

There is no intervening event argument between the matrix T and the event argument of the complement clause, and there is no clear reason why T cannot control e-PRO. In this respect, Felser's explanation of the unacceptability of (36) is untenable.

Finally, if Felser's proposal that passives like (36) are rescued by the insertion of *to* is correct, it is still a mystery as to why idiom chunks cannot appear in the passive of perception verbs, as in (25), repeated as (44).

- (44) a. I saw the shit hit the fan.
 b. *The shit was seen to hit the fan. (= (25))

If the sole difference between (44a) and (44b) were the appearance of *to*, (44b) would be as acceptable as (44a), contrary to fact.

5.2.3.1. Review of Basilico (2003)

Basilico (2003) analyzes small clauses (SCs) as Top(ic)P and

proposes that the complements of perception verbs are SCs. He treats the italicized strings in (45) as two representative SCs.

- (45) a. We consider *the guard intelligent*.
b. We saw *the guard leave*. (Basilico (2003: 1))

He calls SCs like (45a) adjectival SCs and SCs like (45b) verbal SCs.

According to his analysis, the syntax of adjectival SCs and verbal SCs are quite different. He observes that verbal SCs involve athetic predication, while adjectival SCs involve a categorical predication. With a categorical predication, the subject is singled out from the event itself, and the predicate ascribes a property to this subject. With athetic predication form, the subject is not singled out, but instead is introduced as one of the event participants. In the former case, the subject forms the topic of the clause, but in the latter case, the subject is not a topic. According to Raposo and Uriagereka (1995), sentences with stage-level predicates involve thetic predications, whereas sentences with individual-level predicates involve categorical predications. As Felser (1998) points out, Basilico (2003) also observes that verbal SC complements allow only eventive, stage-level predicates and disallow individual-level predicates, as shown below:

- (46) a. The burglar saw the prisoner escape.
b. *The burglar saw the prisoner know French.
(Basilico (2003: 4))

In contrast, adjectival SC complements allow individual-level predicates, as in (47).

- (47) a. The guard considers the prisoner intelligent.

- b. The guard judged the work acceptable.

(Basilico (2003: 4))

Considering these facts, Basilico suggests that the subject of adjectival SCs and that of verbal SCs are located in different positions.

In order to support this notion, he takes up some examples where a *wh*-phrase is extracted from the postverbal DP, as follows:

(48) a.??Which subject_i do you consider [a book about *t_i*] too boring for your class?

b.??Who_i did you find [a photograph of *t_i*] rather unattractive?

c.??Who_i did you judge [a rumor about *t_i*] false?

(49) a. Which planet_i did you see [a picture of *t_i*] appear on your computer screen?

b. Who_i did you let [a rumor about *t_i*] spread around the entire department?

c. Which president_i did you watch [a picture of *t_i*] burn in the wastebasket? (ibid.: 5)

He observes that extraction from the postverbal DP with perception and causative verbs is better than extraction from the postverbal DP with opinion verbs. He ascribes the unacceptability in (48) to the violation of the Subject Condition, which indicates that the subjects of adjectival SCs are typical subjects and the subjects of verbal SCs behave like objects. The subject of an adjectival SC has moved out of the domain of the θ -role-assigning head of the SC into a functional projection (FP). On the other hand, the subject of a verbal SC has not moved out of the domain of the head that assigns it a θ -role.

- (50) a. [_{FP} DP_i [_{AP} t_i A]]
 b. [_{FP} [_{VP} DP_i V]]

Since adjectival SCs involve a categorical predication, where the subject is singled out, the subject becomes the topic of the clause. In other words, the subject of an adjectival SC is raised out of the lexical head of the SC and occupies a topic position. With verbal SCs, on the other hand, the subject does not form a topic and is not raised to the subject position. Basilico assumes that the functional projection in (50) is Topic Phrase (TopP). Thus, the subject of an adjectival SC is raised to SPEC-Top. However, there is no such movement in verbal SCs. According to Raposo and Uriagereka (1995), with athetic predication, the entire predicate becomes what the sentence is about and hence the topic of the clause. Tense or some other verbal functional element is the topic of such sentences. The trouble is that verbal SCs lack any sort of verbal functional element; they do not occur with any tense marking, modals, or auxiliaries, as in (51).

- (51) a. *The policeman saw the prisoner left.
 b. *The policeman saw the prisoner can leave.
 c. ??The policeman saw the prisoner be arrested.
 d. *The policeman saw the prisoner be leaving.

(Basilico (2003: 9))

Instead, he suggests that there is a null pronominal element that functions as the stage topic of verbal SCs. He proposes that this null element is the spatiotemporal (event) argument, expressed in the syntax as *pro*. In his proposal, *pro* has an index *t*, which gives the time and

location of the stage. Therefore, *pro* functions as the topic of verbal SCs.

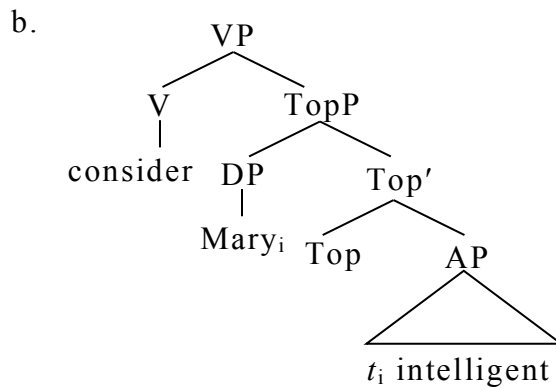
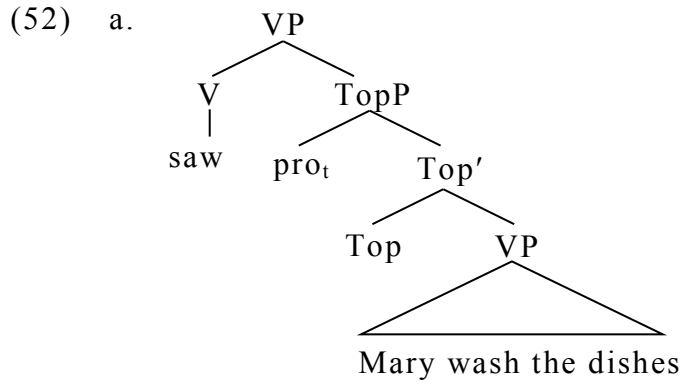

Considering the above discussion, Basilico explains why the subject of a verbal SC cannot be passivized, while that of an adjectival SC can, by presenting the following structures:

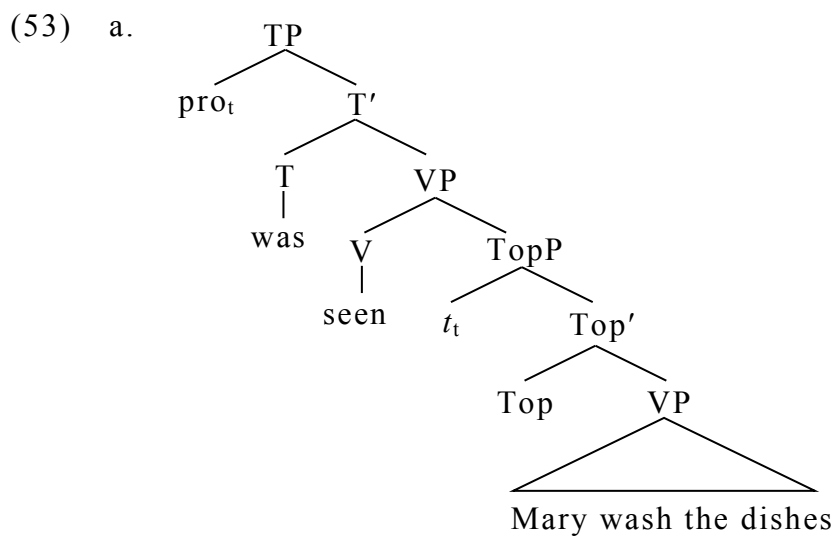

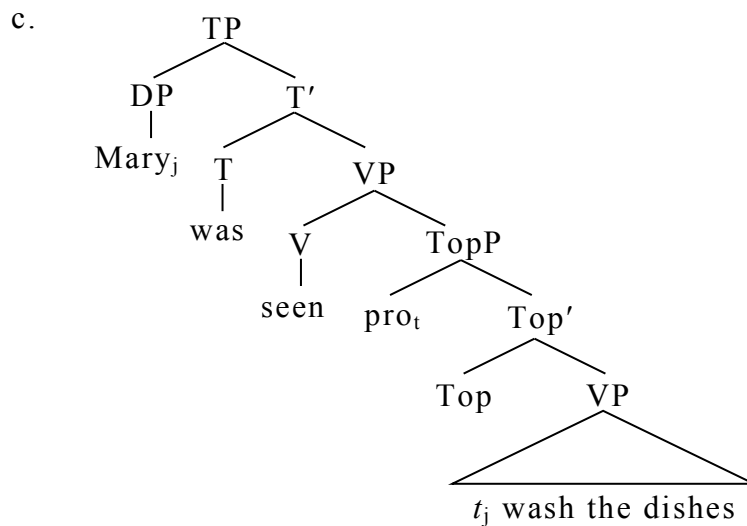
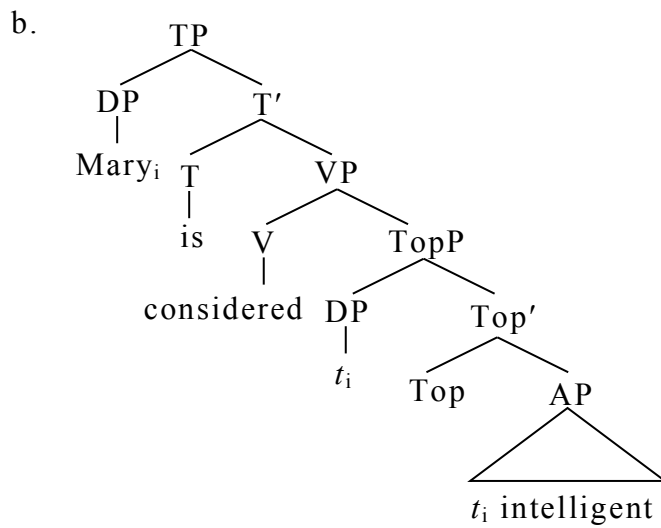

Note that although this *pro* refers to an event, it has a nominal (D-) feature. Thus, when the matrix verb is passivized, it is not *Mary* but *pro* in (53a) that is the closest nominal element to be attracted by T. Basilico assumes that the derivation in (53a) crashes because *pro* cannot check the nominative Case feature of T. This problem does not arise in (53b) since there is no intervening element between T and *Mary*. The derivation in (53c) violates economy conditions, since *Mary* is not the closest element attracted by T.

In Higginbotham's (1985) system, transitive verbs such as *eat* take

three arguments, the two typical arguments that are the agent and patient of the verb plus an event argument.

(54) eat <e, x, y>

The *x* and *y* arguments are saturated by the DPs, i.e. the subject and the object. The event argument, on the other hand, is saturated after combining with I(nfl) in a process called *θ-binding*. Basilico proposes that in a verbal SC, the event argument, i.e. *pro*, must be introduced syntactically to saturate the event argument position, since verbal SCs lack I. This case is shown in (55), where a star by the argument position in the *θ*-grid shows that particular argument position has been saturated.

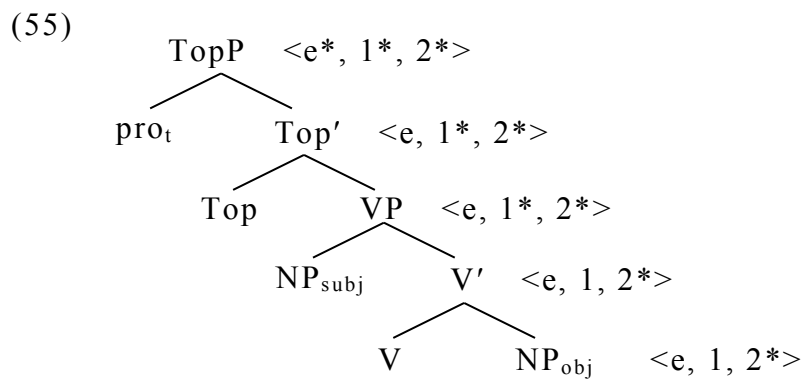

(Basilico (2003: 11))

At this point in the analysis, we need to account for why *pro* is required to appear in TopP and why *pro* is allowed in English. To answer the first question, let us observe the following Italian examples:

(56) a. Questa mattina, la mostra è stata visitata da
 this morning the exhibition was visited by
 Gianni. Più tardi, *e/egli/lui ha visitato l'università.
 Gianni later he has visited the university

‘This morning, the exhibition was visited by Gianni. Later, he visited the university.’

- b. Questa mattina, Gianni ha visitato la mostra. Più tardi, *e/?*egli/?lui ha visitato l’università.

(Basilico (2003: 16–17))

Null subjects can be used in Italian when the antecedent of the null subject is the topic of the discourse. The antecedent of the null subject is inside the *by*-phrase in (56a), which is not a topic. On the other hand, in the active sentence in (56b), *Gianni* is the subject, which can be a topic, and the subject of the following sentence can be null. A Null pronoun is used only when its antecedent is maximally prominent in the discourse, i.e., when it is topical. Thus, there is a close relationship between *pro* and topics, and *pro* must be in a topic position in order to be licensed.

As for second question, we can propose that *pro* can appear in English because this *pro* lacks ϕ -features. Italian has rich agreement in the verb, which is essential for *pro* to acquire its ϕ -features. Unlike the *pro* that refers to individuals, event *pro* does not need to set its ϕ -features.

As we have seen in (53a), *pro* blocks the raising of the subject of a verbal SC to the matrix subject position in the passive. This seems to be problematic for the Case assignment to the SC subject in the active, since *pro* seems to intervene between the Case-assigner and the SC subject. To account for this, Basilico adopts Stowell’s (1991) proposal that the embedded predicate of an adjectival SC in English undergoes

head movement at LF and incorporates into the matrix verb. Basilico extends this analysis to verbal SCs. The verb moves to Top, and the Top-V complex then moves to the matrix V at LF, as in (57).

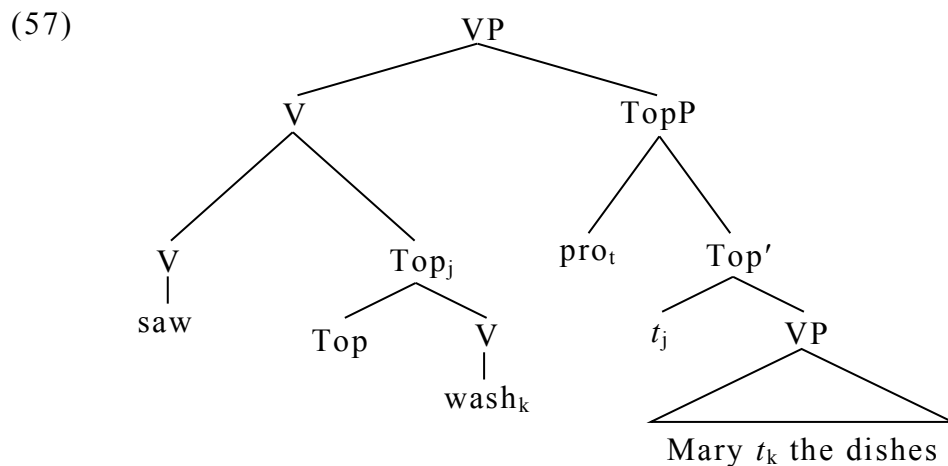

Note that after this LF movement, the specifiers of TopP and the matrix VP become equidistant from *Mary* as a result of the movement of the head of TopP. According to Basilico's analysis, the specifier of VP is a possible landing site, since it is not a θ -position. Thus, *Mary* can be raised to SPEC-Agr_O via SPEC-V, as illustrated in (58).

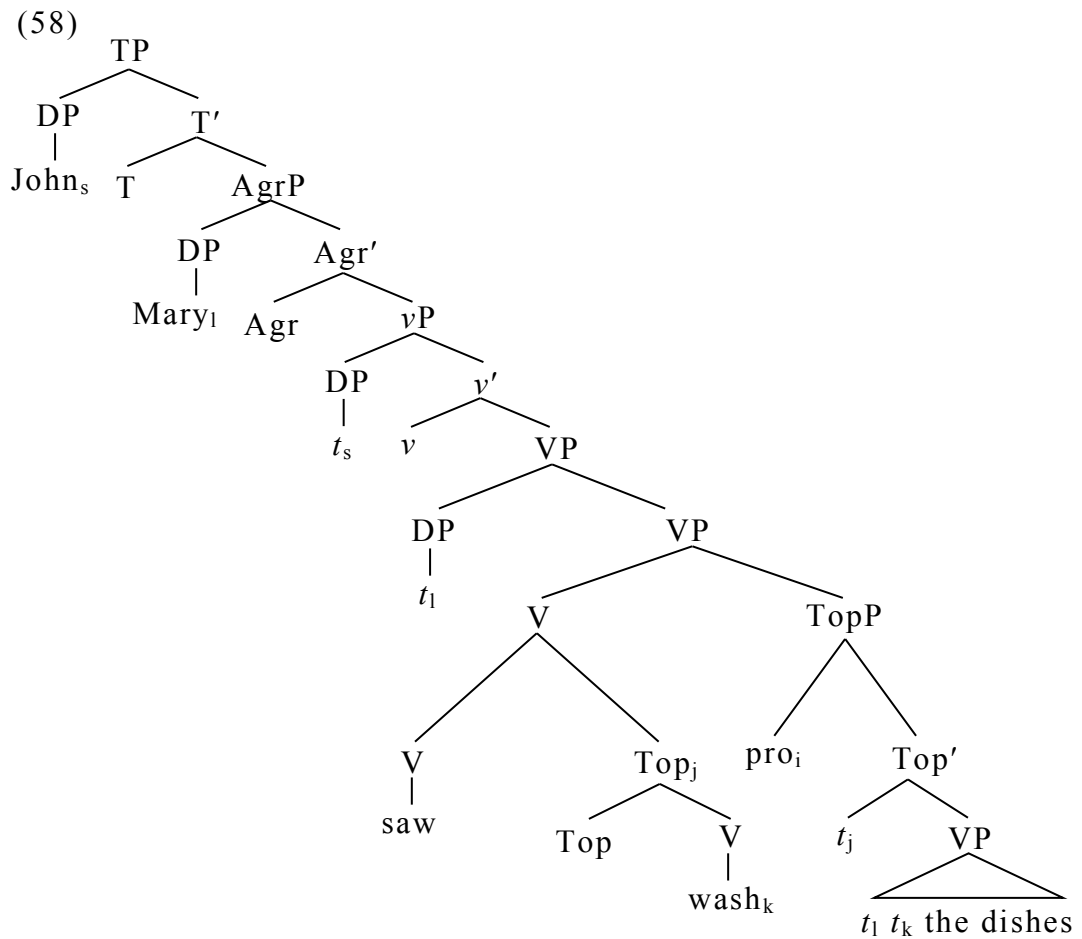

Furthermore, in order to account for the derivation of sentences like (59), Basilico assumes two separate lexical items, *made* and *was made*, as in (60).

- (59) a. The prisoner was seen to leave.
 b. The prisoner was made to leave. (Basilico (2003: 29))
- (60) a. made [_{VP} the prisoner leave]
 b. was made [_{NP} the prisoner] [_{CP} PRO to leave] (ibid.)

The active form of perception verbs is derived from (60a), while sentences like (59) are derived from (60b). Basilico presents the following contrast as the evidence for this claim:

- (61) a. The prisoner was made to wash the floor.

b. The floor was made to be washed. (Basilico (2003: 29))

In (61a), the embedded infinitival is interpreted as a caused event, which indicates that the infinitival *to wash the floor* as a whole is the complement of the verb *was made*. In (61b), on the other hand, the infinitival *to be washed* is interpreted as an adjunct, i.e. purpose close interpretation, accounting for why *the floor* was created. If the embedded infinitival is passivized, it loses the complement interpretation. This shows that the complement of the verb *was made* is not IP, as shown in (62).

(62) [_{IP} was made [_{IP} to be washed [the floor]]]

This fact supports the argument structure in (60b).

5.2.3.2. Examination of Basilico (2003)

Basilico's analysis is able to capture the important notion that the complement of perception verbs must contain a stage-level predicate, which Felser (1998) also points out. In addition, Basilico's analysis can explain why clausal idioms cannot appear in the passive of perception verbs. As we see in (60b), the passive form of perception verbs cannot take clausal idioms as complements.

However, even Basilico's analysis faces some technical and empirical problems.

First, although Basilico assumes that the subject of a verbal SC is raised to the specifier of the matrix VP due to the movement of the head of TopP to the matrix V, it is unclear why it is impossible for the SC subject to move to SPEC-V in the passive, as shown below:

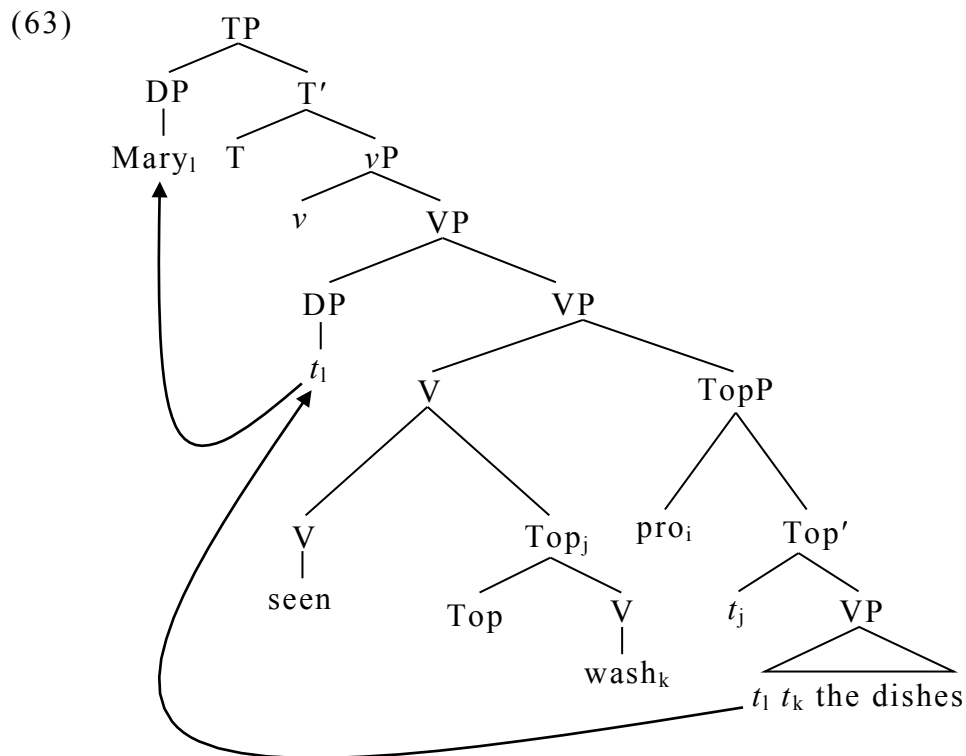

Basilico may argue against this question by adopting Bennis and Hoekstra's (1989) observation that verb raising cannot apply when the matrix verb has been passivized in Dutch. However, there is no such evidence in English. What prevents the Top-V complex from moving into passivized verbs is still unclear.

Second, assuming the two separate lexical items as in (60) seems to be an ad hoc analysis. The causative verb *make* can also appear in the *get* passive, as shown in (64).

(64) They got made to leave.

Then, we must assume the following lexical item in addition to (60):

(65) got made NP CP

Therefore, Basilico's analysis of the derivation of (59) is untenable.

5.3. Proposal

To sum up the previous analyses, we must pay attention to the following properties of perception and causative verbs:

- (66) a. The active and passive forms of perception verbs are derived from different structures.
- b. The complement of perception verbs must contain a stage-level predicate.

Considering these properties, I adopt Basilico's (2003) analysis, which can account for (66), with some important modifications.

As I have proposed in chapter 2, both the active and the passive are derived from the structure in (67).

- (67) [_{v*P} EA [_{v*} [_{VoiceP} Voice [_{VP} V IA]]]]

EA = external argument, IA = internal argument

The difference between the active and the passive is related to the head of VoiceP. If the head of VoiceP is the phonetically null $-\emptyset$, the active is derived. On the other hand, the passive is derived if the head of VoiceP is the passive morpheme *-en*. In order to support the structure in (67), I have proposed the following conditions in (68).

- (68) a. v^* merges DP iff v^* selects $-\emptyset$.
- b. v^* merges IMP and is assigned an EPP-feature iff v^* selects *-en*.

Following the structure in (67), I propose that the syntactic structure of (69a) is (69b).

(69) a. John saw Mary leave.

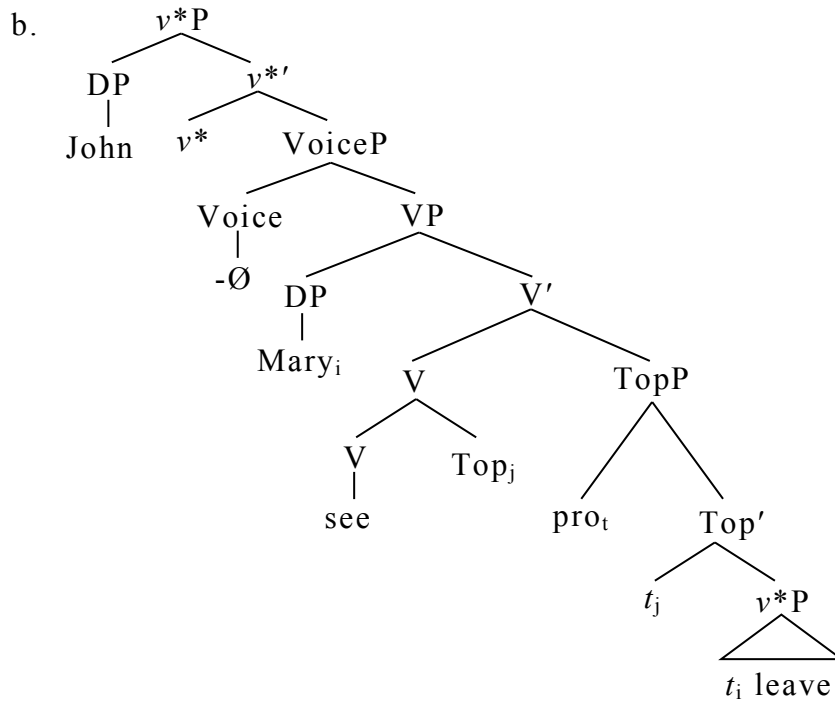

Unlike Basilico (2003), I assume that only the head of TopP moves into the matrix verb in narrow syntax. This movement makes the specifier of the matrix verb and the specifier of TopP equidistant from the SC subject *Mary*. Thus, the SC subject is raised to SPEC-V and assigned accusative Case by V, which inherits the Agree-feature of v^* .

On the other hand, the structure of the ungrammatical passive in (70a) will be (70b).

(70) a. *Mary was seen leave.

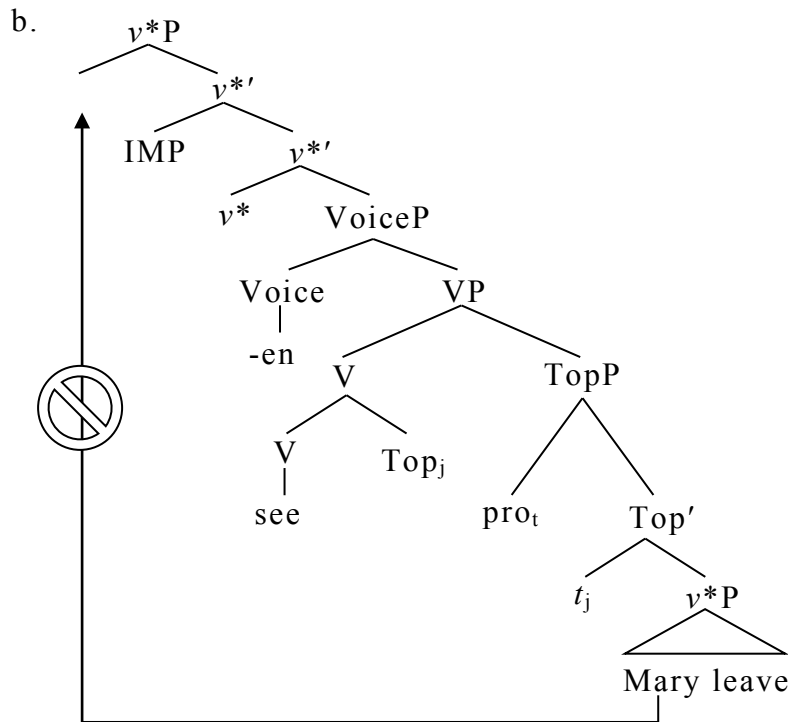

Note that the specifier of v^* and the specifier of TopP are not equidistant from *Mary*, which causes *pro* to intervene between v^* and the SC subject *Mary*. If *pro* is raised to SPEC- v^* instead of *Mary*, the derivation crashes as we have already seen in (53a). For this reason, perception and causative verbs with bare infinitives cannot be passivized.

5.4. What Looks like the Passive Counterpart

The next question is how sentences like (71) are derived.

(71) a. ?*Mary was seen to leave by John.

b. Mary was made to run by John.

Most of my informants, however, judged sentences like (71a) to be unacceptable. Some of them pointed out that putting the *by*-phrase after *seen* makes the sentence a little better, as in (72), but it still has a

different meaning from the active sentence in (69a).

(72) ??Mary was seen by John to leave.

One of the informants claimed that in the case of the passive, the meaning of the verb *see* can be metaphorical, i.e., to become aware of something. This notion follows Felser's (1998, 1999) observation, and we can conclude that the structure of (72) is quite different from (69). Felser claims that the sense of direct perception is lost in the passive. Instead, the passive forms of perception verbs describe an act of indirect (or epistemic) perception. This is the reason why the verb *watch*, which only has the sense of direct perception, does not have the passive counterpart.

(73) a. We watched John draw a circle.

b. *John was watched (to) draw a circle. (= (24))

Thus, the analyses that the active and passive forms of perception verbs are derived from the same base-structure, as proposed in Hornstein et al. (2008), are untenable. In fact, sentences like (69a) cannot be passivized at all, and I assume that contrary to the literature, the string *be seen to* or *be heard to* can appear only in the following examples, which do not have any active counterparts:

(74) a. *I saw John know French.

b. John was seen to know French. (= (8))

(75) a. *I heard John have an accent.

b. John was heard to have an accent. (= (9))

As we have already seen, Hornstein et al. suggest that these sentences, which have propositional/epistemic readings, behave like *wager*-class

verbs.

On the other hand, passive sentences of causative verbs like (71b) are perfectly acceptable. However, (76b) does not have the active counterpart, as in (76a).

(76) a. *We made John be in need of assistance.

b. John was made to be in need of assistance.

(Inoue (1992: 144))

Thus, the active sentence in (77), which looks like the active counterpart to (71b), and (71b) are derived from different structures.

(77) John made Mary run.

These are reminiscent of *wager*-class verbs, as in (78), in that there is no active-passive pair.⁵

(78) a. *John wagered Peter to be crazy (Bošković (1997 :52))

b. Peter_i was wagered by John [_{*t*}_{*i*} to be _{*t*}_{*i*} crazy] (ibid.: 55)

c. Who_i did John wager [_{*t*}_{*i*} to be _{*t*}_{*i*} crazy] (ibid.:61)

Therefore, we expect that the perception and causative verbs that take *to*-infinitives as complements must have a similar syntactic structure to *wager*-class verbs.

Bošković (1997) explains this peculiar behavior of *wager*-class verbs within an Agr-based analysis, but we do not assume Agr projection.

⁵ Active sentences of *wager*-class verbs are allowed when the embedded subject undergoes *wh*-movement. One of my informants accepts (i), although most of them do not.

(i) (*)Who did John make to run?

I am not sure why most native speakers do not accept sentences like (78c) in causative verb sentences, and I leave this issue for future research.

Nishikawa and Matsumoto (2007) present a phase-based approach to verbs of this class.⁶ They note that *wager*-class is different from *believe*-class in that only the former assigns an Agent θ -role, and that they are similar because they both assign Experiencer θ -role, as shown in (79)–(80).

- (79) a. Mike viciously alleged/announced her to be a liar.
b.?*Mike viciously believed her to be a liar.
- (80) a. Mike personally alleged/announced her to have accepted his proposal.
b. Mike personally expected her to accept his proposal.

(Nishikawa and Matsumoto (2007: 235))

The verbs *allege* and *announce* belong to *wager*-class. Manner adverbs like *viciously* may occur only in sentences having underlying Agents. This is the reason why (79b) is unacceptable. On the other hand, the adverb *personally* appears only in sentences with Experiencers. Nishikawa and Matsumoto conclude that *wager*-class verbs project both Agent and Experiencer, while *believe*-class verbs project only the latter.

Taking this analysis into consideration, they assume the structures for *wager*-class verbs and *believe*-class verbs as follows:

⁶ I thank Koji Fujita for pointing out this study to me.

(81) a. *John wagered Peter to be crazy. (= (78a))

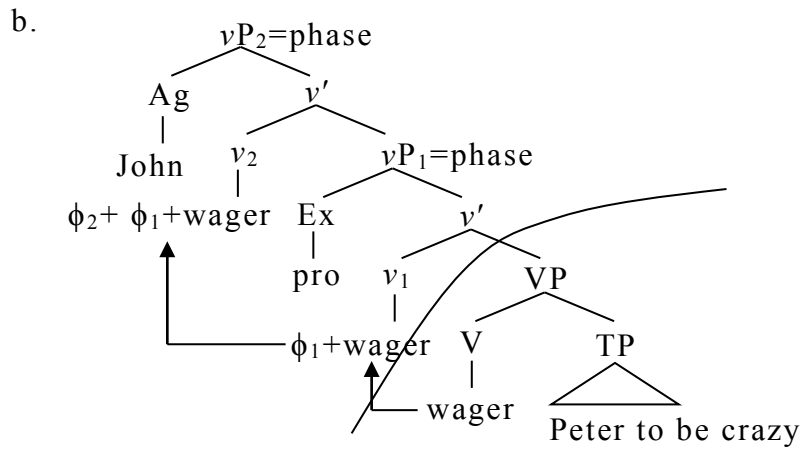

(Nishikawa and Matsumoto (2007: 236))

(82) a. John believed Peter to be crazy.

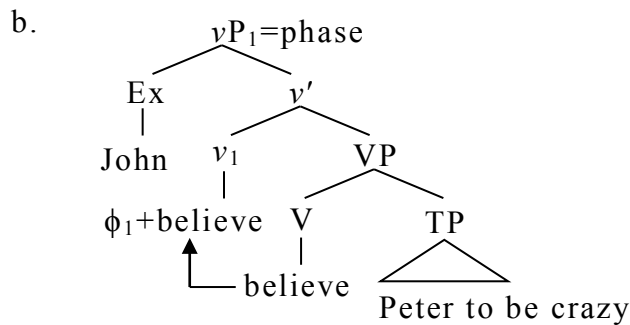

(ibid.)

In (81b), V head moves into ϕ_1 and then the $\phi_1 + V$ complex moves into ϕ_2 . According to their analysis, vP_1 is a phase, which takes Experiencer *pro* as an external argument.⁷ Moreover, vP_2 is also a phase, which takes Agent *John* as another external argument. They assume that only v_2 can assign accusative Case, and that v_1 just heads a

⁷ One might claim that assuming *pro* in English is problematic. However, if we adopt Bošković's (1997) assumption that an argument can move from one θ -position to another θ -position, we can claim that *John* is base-generated at SPEC- v_1 and then moves to SPEC- v_2 in (81b). This analysis is in the same vein as Fujita and Matsumoto (2005).

phase. Note that v_2 cannot access *Peter* since vP_1 is a phase and only the specifier and the head of vP_1 are accessible to the external probe v_2 . This is the reason why (81a) is ungrammatical. In (82b), on the other hand, v_1 can assign accusative Case to *Peter*.

Moreover, they also account for the reason why the *wh*-phrase in (83) can be assigned Case.

(83) Who did John wager to be crazy? (= (78c))

According to their analysis, the *wh*-phrase is raised to SPEC- v_1 and is assigned Case in that position by v_2 .⁸

Adopting their analysis, I propose the following structure for the perception and causative verbs that take *to*-infinitives:⁹

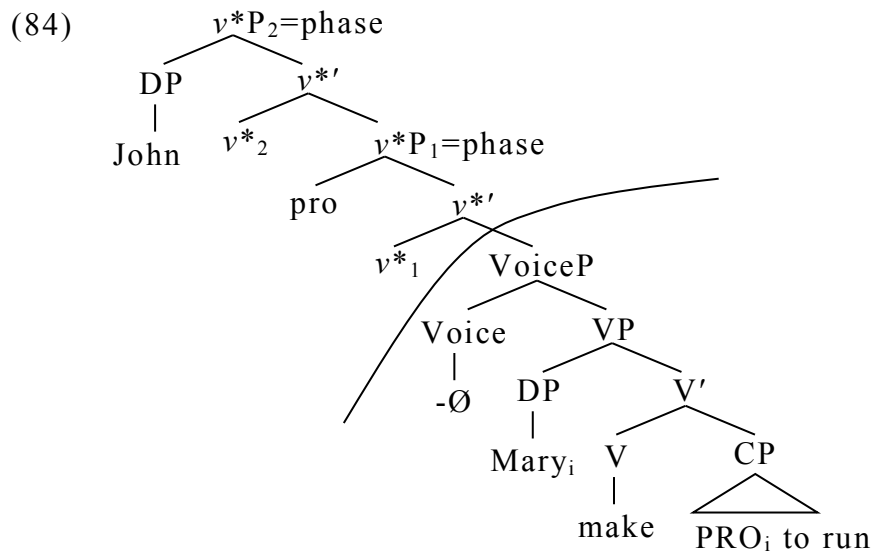

In (84), I partially adopt Basilico's analysis in that the lexical verb takes two internal arguments, i.e. DP and CP whose subject is PRO.¹⁰

⁸ Nishikawa and Matsumoto do not refer to the passive in (78b).

⁹ I am not sure whether the two external arguments are Agent and Experiencer in this case. I tentatively assume that there are also two light verbs in this structure.

¹⁰ I assume that the Agree-feature on v^*_2 remains on v^*_2 because v^*_2 does not

Furthermore, I propose the following structure as the passive counterpart to (84):

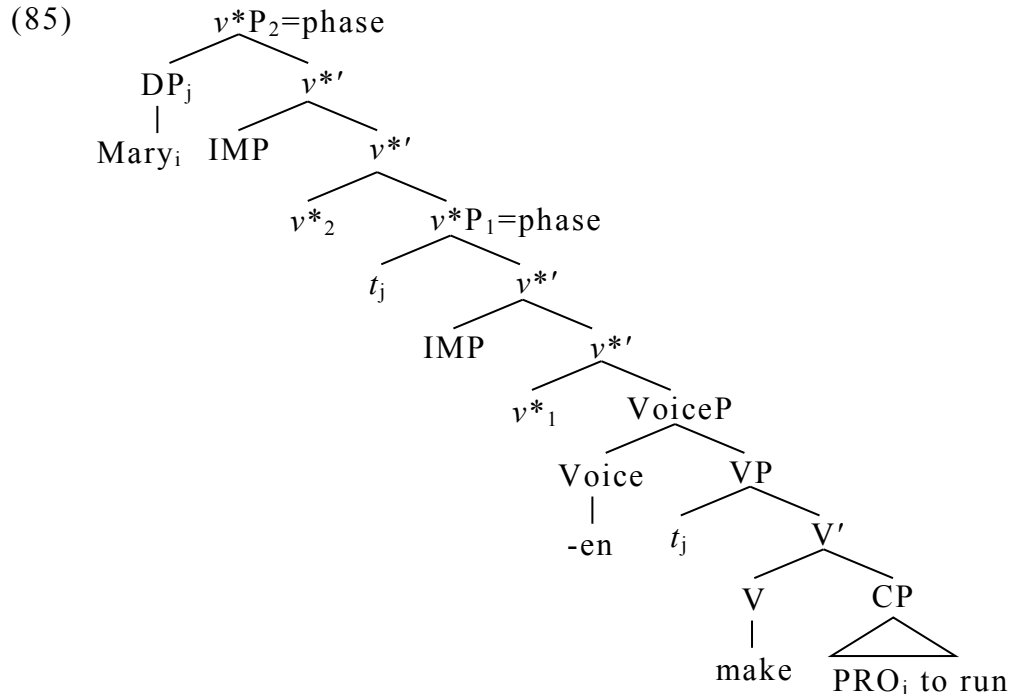

In (85), I suggest that each v^* merges *IMP* and is assigned an EPP-feature.

By partially adopting Basilico's argument structure in (60b), the structure in (85) can also explain why (61a) and (61b), which I repeat here as (86a) and (86b), respectively, have different interpretations.

- (86) a. The prisoner was made to wash the floor.
 b. The floor was made to be washed. (= (61))

This analysis also accounts for the clausal idiom examples, as in (87).

- (87) a. I saw the shit hit the fan.
 b. *The shit was seen to hit the fan. (= (25))

As we have already discussed, the passive form of a perception verb describes an act of indirect (or epistemic) perception. If (87b) had the

select V in (84).

same structure as *wager*-class verbs, we could not explain its deviance from that structure. Alternatively, if we adopt the structure in (85), we can explain why (87b) does not have the idiomatic reading because the verb takes only *the shit* as an argument and it cannot take the clausal idiom as a complement.

5.5. Conclusion

In this chapter, we have discussed the reason why the perception and causative verbs that take bare infinitives cannot be passivized. This is because *pro*, which is merged at SPEC-Top, intervenes between v^* and the embedded subject. Thus, the embedded subject cannot be raised to the subject position. This intervention is not problematic for accusative Case assignment to the embedded subject in the active. In addition, the passive forms of perception and causative are derived from a structure that is similar to the structure of *wager*-class verbs, but they are different in that the former takes two internal arguments, i.e. DP and CP.

CHAPTER SIX
CONCLUDING REMARKS

In this thesis, we have discussed the syntactic structure of passive constructions under the Minimalist Program framework. With respect to Japanese passives, we adopt Hoshi's (1991) proposal that the *niyotte* passive corresponds to the English *be* passive but the *ni* direct passive does not. However, we reject his claim that an external θ -role is never assigned in passives, just like the case with unaccusatives. In this respect, we adopt Matsuoka's (2003) proposal that the transitive light verb, which projects the external argument, is also present in passives, but we focus on the accusative Case assignment of the light verb, which he does not discuss.

By demonstrating not only that there is an implicit external argument in passives but also that an accusative Case value is assigned in some passive sentences, we argue that the transitive light verb v^* is included in the derivation of passives. Adopting Multiple Agree and the Principle of Simultaneity presented by Hiraiwa (2005), we claim that in the passive, an internal argument agrees with both the Agree feature and the EPP-feature of v^* simultaneously. This claim can explain why the internal argument is raised to SPEC-T without violating the PIC.

We have observed that accusative Case is assigned in the passive of the DOC in some dialects of English and some other languages as well as in the passive of the Possessor-Raising Construction in Japanese and in

some Ukrainian passive sentences. These phenomena can be accounted for by the structure of passives that we propose in this thesis.

In addition, we have presented further evidence that supports Hoshi's claim that the *niyotte* passive corresponds to the *be* passive by dividing idioms in Japanese and English into two types: Type I idioms and Type II idioms. We have claimed that Type I idioms can be passivized, and that Type II idioms can also be passivized in Japanese as long as the nominative idiom chunk stays at SPEC-*v**. Both types of idioms can appear only in the *niyotte* passives. This fact supports Hoshi's claim. In addition, assuming the special θ -role for semantically vacuous arguments makes it possible to explain the passivizability of Type II idioms in Japanese and English. The difference between these languages can be accounted for by Miyagawa's (2005) focus-agreement parameter.

Moreover, we have observed that Reanalysis is an unnecessary notion to account for the derivation of pseudopassives. We have proposed that prepositions assign Case to their complements not by Agree but by incorporation, and that PPs are non-phases in the languages where pseudopassivization is possible. With this proposal, the complement of P can be raised to SPEC-*v** in the passive, which makes it possible for the complement of P to be the subject of a pseudopassive sentence. This raising is impossible in the languages where PPs are phases because such a movement violates the PIC. Additionally, the parameterization of the escape hatch of PPs enables us to explain P-stranding under \bar{A} -Movement.

Finally, we have claimed that it is impossible to passivize perception and causative verbs that take bare infinitives. Taking into account Basilico's (2003) analysis, we suggest that *pro*, which is the specifier of TopP, intervenes between v^* and the embedded subject. This is why the embedded subject of these verbs cannot be passivized, although it is assigned accusative Case in the active. Furthermore, we propose that the argument structure of perception and causative verbs with *to*-infinitives is similar to the structure of *wager*-class verbs. This is why perception and causative verbs cannot appear with *to*-infinitives in the active, although they can appear in the passive.

Thus, the research presented in this dissertation successfully accounts for various phenomena in passive constructions under the Minimalist Program framework.

REFERENCES

- Abels, Klaus (2003) *Successive Cyclicity, Anti-locality, and Adposition Stranding*, Doctoral dissertation, University of Connecticut, Storrs.
- Amano, Masachiyo (1998) *Eigo Nijumokutekigo Kobun no Togokozo ni kansuru Seisei Rironteki Kenkyu* (A Generative Approach to the Syntactic Structure of Double Object Constructions in English), Eichosha, Tokyo.
- Baker, Mark C., Kyle Johnson and Ian Roberts (1989) "Passive Arguments Raised," *Linguistic Inquiry* 20, 219–251.
- Baltin, Mark and Paul M. Postal (1996) "More on Reanalysis Hypotheses," *Linguistic Inquiry* 27, 127–145.
- Basilico, David (2003) "The Topic of Small Clauses," *Linguistic Inquiry* 34, 1–35.
- Bennis, Hans and Teun Hoekstra (1989) "Why Kaatje Was Not Heard Sing a Song," *Sentential Complementation and the Lexicon: Studies in Honor of Wim de Geest*, ed. by Dany Jaspers, Wim Klooster, Yvan Putseys, and Pieter Seuren, 21–40, Foris, Dordrecht.
- Bobaljik, Jonathan David (1994) "What Does Adjacency Do?," *MIT Working Papers in Linguistics* 22, 1–32.
- Boeckx, Cedric (2000) "Quirky Agreement," *Studia Linguistica* 54, 354–380.
- Bošković, Željko (1997) *The Syntax of Nonfinite Complementation: An Economy Approach*, MIT Press, Cambridge, MA.
- Carrier, Jill and Janet H. Randall (1992) "The Argument Structure and

- Syntactic Structure of Resultatives,” *Linguistic Inquiry* 23, 173–234.
- Chomsky, Noam (1980) *Rules and Representations*, Columbia University Press, New York.
- Chomsky, Noam (1981) *Lectures on Government and Binding*, Foris, Dordrecht.
- Chomsky, Noam (1986) *Knowledge of Language: Its Nature, Origin and Use*, Praeger, New York.
- Chomsky, Noam (1995) *The Minimalist Program*, MIT Press, Cambridge, MA.
- Chomsky, Noam (2000) “Minimalist Inquiries: The Framework,” *Step by Step: Essays on Minimalist Syntax in Honor of Howard Lasnik*, ed. by Roger Martin, David Michaels and Juan Uriagereka, 89–155, MIT Press, Cambridge, MA.
- Chomsky, Noam (2001) “Derivation by Phase,” *Ken Hale: A Life in Language*, ed. by Michael Kenstowicz, 1–52, MIT Press, Cambridge, MA.
- Chomsky, Noam (2004) “Beyond Explanatory Adequacy,” *Structures and Beyond: The Cartography of Syntactic Structures, Volume 3*, ed. by Adriana Belletti, 104–131, Oxford University Press, Oxford.
- Chomsky, Noam (2008) “On Phases,” *Foundational Issues in Linguistic Theory: Essays in Honor of Jean-Roger Vergnaud*, ed. by Robert Freidin, Carlos P. Otero and Maria Luisa Zubizarreta, 133–166, MIT Press, Cambridge, MA.
- Collins, Chris (2005) “A Smuggling Approach to the Passive in English,” *Syntax* 8, 81–120.

- Culicover, Peter W. and Ray Jackendoff (2005) *Simpler Syntax*, Oxford University Press, Oxford.
- Delahunty, Gerald (1983) “But Sentential Subjects Do Exist,” *Linguistic Analysis* 12, 379–398.
- Drummond, Alex (2008) “Reconstruction and English PPs,” paper presented at ECO5, University of Connecticut.
- Drummond, Alex (2011) *Binding Phenomena within a Reductionist Theory of Grammatical Dependencies*, Doctoral dissertation, University of Maryland, College Park.
- Drummond, Alex, Norbert Hornstein and Howard Lasnik (2010) “A Puzzle about P-Stranding and a Possible Solution,” *Linguistic Inquiry* 41, 689–692.
- Emonds, Joseph E. (1976) *A Transformational Approach to English Syntax: Root, Structure-Preserving, and Local Transformations*, Academic Press, New York.
- Felser, Claudia (1998) “Perception and Control: A Minimalist Analysis of English Direct Perception Complements,” *Journal of Linguistics* 34, 351–385.
- Felser, Claudia (1999) *Verbal Complement Clauses: A Minimalist Study of Direct Perception Constructions*, John Benjamins, Amsterdam.
- Fox, Danny and Yosef Grodzinsky (1998) “Children’s Passive: A View from the *By*-Phrase,” *Linguistic Inquiry* 29, 311–332.
- Fujita, Koji (1994) “Middle, Ergative and Passive in English: A Minimalist Perspective,” *MIT Working Papers in Linguistics* 22, 71–90.

- Fujita, Koji and Masumi Matsumoto (2005) *Goihanchu (I): Doshi* (Lexical Category (I): Verbs), Kenkyusha, Tokyo.
- Givón, Talmy (1975) “Cause and Control: On the Semantics of Interpersonal Manipulation,” *Syntax and Semantics* 4, ed. by John Price Kimball, 59–89, Academic Press, New York.
- Goldberg, Adele E. (2002) “Surface Generalizations: An Alternative to Alternations,” *Cognitive Linguistics* 13, 327–356.
- Guasti, Maria Teresa (1993) *Causative and Perception Verbs : A Comparative Study*, Rosenberg and Sellier, Torino.
- Hale, Kenneth and Samuel Jay Keyser (1991) “On the Syntax of Argument Structure,” *Lexicon Project Working Papers* 34, Center for Cognitive Science, MIT.
- Harada, S. I. (1973) “Counter Equi NP Deletion,” *Annual Bulletin* 7, 113–147, Research Institute of Logopedics and Phoniatics, University of Tokyo.
- Harada, S. I. (1977) “Nihongo ni Henkei wa Hitsuyo da (Transformation is Necessary in Japanese),” *Gengo* 6(10), 88–95.
- Hasegawa, Nobuko (1990) “Genri to Parameter no Approach ni okeru Judo-Kobun (Passives in the Principles-and-Parameters Framework),” *Ninchi Kagaku no Hatten* (Advances in Japanese Cognitive Science), Vol. 2, ed. by the Japanese Cognitive Science Society, 89–107, Kodansha, Tokyo.
- Hasegawa, Nobuko (2001) “Causatives and the Role of *v*: Agent, Causer, and Experiencer,” *Linguistics and Interdisciplinary Research: The Proceedings of the COE International Symposium*, ed. by Kazuko

- Inoue and Nobuko Hasegawa, 1–35, Kanda University of International Studies.
- Hasegawa, Nobuko (2004) “The Possessor Raising Construction: Transitivity, Causative, and Experiencer,” *Scientific Approaches to Language* 3, 35–74, Kanda University of International Studies.
- Higginbotham, James (1985) “On Semantics,” *Linguistic Inquiry* 16, 547–594.
- Hiraiwa, Ken (2005) *Dimensions of Symmetry in Syntax: Agreement and Clausal Architecture*, Doctoral dissertation, MIT.
- Hiraiwa, Ken (2008) “Multiple Spell-Out and PF: A Case of the Double-o Constraint,” paper presented at Generative Lyceum, Kwansai Gakuin University, Hyogo, Japan.
- Honda, Takahiro (2009) “Accusative Case in the Passive,” *English Linguistics* 26, 33–66.
- Honda, Takahiro (2010a) “SPEC-T in Passive Constructions,” *JELS* 27, 51–60.
- Honda, Takahiro (2010b) “Zenchishiku no Hitaikakusei to Gijijudobun nitsuite (On the Unaccusativity of Prepositional Phrases and Pseudopassives),” *Machikaneyama Ronso* 44, 51–67, Osaka University.
- Honda, Takahiro (2011) “Chikakudoshikobun-no Nodobun-to Judobun nitsuite (On the Active and Passive Forms of Perception Verbs,” *Proceedings of the Thirty-Fifth Annual Meeting of The Kansai Linguistic Society*, 60–71.
- Hornstein, Norbert, Ana Maria Martins and Jairo Nunes (2008)

- “Perception and Causative Structures in English and European Portuguese: ϕ -Feature Agreement and the Distribution of Bare and Prepositional Infinitives,” *Syntax* 11, 198–222.
- Hornstein, Norbert and Amy Weinberg (1981) “Case Theory and Preposition Stranding,” *Linguistic Inquiry* 12, 55–91.
- Hoshi, Hiroto (1991) “The Generalized Projection Principle and Its Implications for Passive Constructions,” *Journal of Japanese Linguistics* 13, 53–89.
- Hoshi, Hiroto (1994) “Theta-Role Assignment, Passivization, and Excorporation,” *Journal of East Asian Linguistics* 3, 147–178.
- Hoshi, Hiroto (1999) “Passives,” *The Handbook of Japanese Linguistics*, ed. by Natsuko Tsujimura, 191–235, Blackwell, Malden, MA.
- Inada, Toshiaki (1981) “Problems of Reanalyses and Preposition Stranding,” *Studies in English Linguistics* 9, 120–131.
- Inoue, Kazuko (1992) “Cause and Make in Semantic Representation,” *English Linguistics* 9, 132–151.
- Jackendoff, Ray (1990) “On Larson’s Treatment of the Double Object Construction,” *Linguistic Inquiry* 21, 427–456.
- Jaeggli, Osvaldo (1986) “Passive,” *Linguistic Inquiry* 17, 587–622.
- Johnson, Kyle (1991) “Object Positions,” *Natural Language and Linguistic Theory* 9, 577–636.
- Johnson, Kyle (2009) “Gapping Is Not (VP-) Ellipsis,” *Linguistic Inquiry* 40, 289–328.
- Julien, Marit (2006) “On Argument Displacement in English and Scandinavian,” *Working Papers in Scandinavian Syntax* 77, 1–69.

- Kageyama, Taro and Hiroyuki Ura (2002) "Peculiar Passives as Individual-level Predicates," *Gengo Kenkyu* 122, 181–199.
- Keyser, Samuel Jay and Thomas Roeper (1984) "On the Middle and Ergative Constructions in English," *Linguistic Inquiry* 15, 381–416.
- Kishimoto, Hideki (2010) "Subjects and Constituent Structure in Japanese," *Linguistics* 48, 629–670.
- É. Kiss, Katalin (1998) "Identificational Focus versus Information Focus," *Language* 74, 245–273.
- Koster, Jan (1978) "Why Subject Sentences Don't Exist," *Recent Transformational Studies in European Languages*, ed. by Samuel Jay Keyser, 53–64, MIT Press, Cambridge, MA.
- Kratzer, Angelika (1995) "Stage Level and Individual Level Predicates," *The Generic Book*, ed. by Gregory Carlson and Francis Jeffrey Pelletier, 125–175, University of Chicago Press, Chicago.
- Kuno, Susumu (1989) "Passive Sentences," ms., Harvard University.
- Kuwabara, Kazuki and Tetsuya Matsuyama (2001) *Hobun Kozo* (The Structure of Complement Clauses), Kenkyusha, Tokyo.
- Larson, Richard K. (1988) "On the Double Object Construction," *Linguistic Inquiry* 19, 335–391.
- Lasnik, Howard (1999a) "Chains of Arguments," *Working Minimalism*, ed. by Samuel David Epstein and Norbert Hornstein, 189–215, MIT Press, Cambridge, MA.
- Lasnik, Howard (1999b) *Minimalist Analysis*, Blackwell, Oxford.
- Lasnik, Howard (2003) *Minimalist Investigations in Linguistic Theory*, Routledge, New York.

- Lasnik, Howard and Robert Fiengo (1974) “Complement Object Deletion,” *Linguistic Inquiry* 5, 535–571.
- Lavine, James E. and Robert Freidin (2002) “The Subject of Defective T(ense) in Slavic,” *Journal of Slavic Linguistics* 10, 253–289.
- Matsuoka, Mikinari (2001) *Linking Arguments to Phrase Structure: A Study of Passives, Psych Verbs, and Ditransitive Verbs in Japanese*, Doctoral dissertation, McGill University.
- Matsuoka, Mikinari (2003) “Two Types of Ditransitive Constructions in Japanese,” *Journal of East Asian Linguistics* 12, 171–203.
- Mihara, Ken-ichi and Ken Hiraiwa (2006) *Shin Nihongo no Togo Kozo* (The Syntactic Structures of Japanese), Shohakusha, Tokyo.
- Miyagawa, Shigeru (1989) *Syntax and Semantics 22: Structure and Case Marking in Japanese*, Academic Press, New York.
- Miyagawa, Shigeru (2001) “The EPP, Scrambling, and *Wh*-in-Situ,” *Ken Hale: A Life in Language*, ed. by Michael Kenstowicz, 293–338, MIT Press, Cambridge, MA.
- Miyagawa, Shigeru (2005) “On the EPP,” *MIT Working Papers in Linguistics* 49, 201–236.
- Miyagawa, Shigeru (2007) “Unifying Agreement and Agreementless Language,” *MIT Working Papers in Linguistics* 54, 47–66.
- Miyagawa, Shigeru (2008) “Why Is There Movement in Natural Language?,” paper presented at the 1st International Spring Forum of the English Linguistic Society of Japan.
- Miyagawa, Shigeru (2010) *Why Agree? Why Move? Unifying Agreement-Based and Discourse-Configurational Languages*, MIT

Press, Cambridge, MA.

Miyagawa, Shigeru and Takae Tsujioka (2004) “Argument Structure and Ditransitive Verbs in Japanese,” *Journal of East Asian Linguistics* 13, 1–38.

Nishikawa, Morio and Tomoko Matsumoto (2007) “Some Aspects of Infinitival Complements in English,” *Memoirs of the Faculty of Education: The Humanities* 56, 229–240, Kumamoto University.

Nunberg, Geoffrey, Ivan A. Sag and Thomas Wasow (1994) “Idioms,” *Language* 70, 491–538.

Oba, Yukio (2011) “Eigo no Dozokumokutekigokobun nitsuite (Properties of English Cognate Object Constructions),” *Machikaneyama Ronso* 45, 95–118, Osaka University.

Omuro, Takeshi (2005) “Kobun no Kihonkei to Henshu (Basic Forms and Their Variants in Constructions: A Suggestion on the Ordering of Grammatical Items),” *Forum of International Development Studies*, 29, 91–105, Nagoya University.

Pesetsky, David (1989) “The Earliness Principle,” ms., MIT.<<http://web.mit.edu/linguistics/people/faculty/pesetsky/earliness.pdf>>

Pesetsky, David and Esther Torrego (2001) “T-to-C Movement: Causes and Consequences,” *Ken Hale: A Life in Language*, ed. by Michael Kenstowicz, 355–426, MIT Press, Cambridge, MA.

Pinker, Steven (1989) *Learnability and Cognition: The Acquisition of Argument Structure*, MIT Press, Cambridge, MA.

Raposo, Eduardo (1987) “Romance Infinitival Clauses and Case Theory,” *Studies in Romance Languages* ed. by Carol Neidle and Rafael A.

- Nuñez Cedeño, 237–249, Foris, Dordrecht.
- Raposo, Eduardo and Juan Uriagereka (1995) “Two Types of Small Clauses (Toward a Syntax of Theme/Rheme Relations),” *Syntax and Semantics 28: Small Clauses*, ed. by Anna Cardinaletti and Maria Teresa Guasti, 179–206, Academic Press, San Diego, CA.
- Rappaport Hovav, Malka and Beth Levin (2008) “The English Dative Alternation: The Case for Verb Sensitivity,” *Journal of Linguistics* 44, 129–167.
- Ritter, Elizabeth and Sara Thomas Rosen (1993) “Deriving Causation,” *Natural Language and Linguistic Theory* 11, 519–555.
- Rizzi, Luigi (1986) “Null Objects in Italian and the Theory of *pro*,” *Linguistic Inquiry* 17, 501–557.
- Rosenbaum, Peter S. (1967) *The Grammar of English Predicate Complement Constructions*, MIT Press, Cambridge, MA.
- Sano, Masaki (1983) “Semantics of Preposition Stranding,” *Tsukuba English Studies* 2, 97–127.
- Shevelov, George Y. (1969) “The Vicissitudes of a Syntactic Construction in Eastern Slavic,” *Scando-Slavica* 15, 171–186.
- Stanley, Jason (2001) “Hermeneutic Fictionalism,” *Figurative Language*, ed. by Peter A. French and Howard K. Wettstein, 36–71, Blackwell, Boston.
- Stowell, Timothy Angus (1981) *Origins of Phrase Structure*, Doctoral dissertation, MIT.
- Stowell, Timothy Angus (1991) “Small Clause Restructuring,” *Principles and Parameters in Comparative Grammar*, ed. by Robert Freidin,

- 182–218, MIT Press, Cambridge, MA.
- Stroik, Thomas S. (1995) “On Middle Formation: A Reply to Zribi-Hertz,” *Linguistic Inquiry* 26, 165–171.
- Stroik, Thomas S. (1996) “Extraposition and Expletive-Movement: A Minimalist Account,” *Lingua* 99, 237–251.
- Takami, Ken-ichi (1992) *Preposition Stranding: From Syntactic to Functional Analyses*, Mouton de Gruyter, Berlin.
- Taraldsen, Tarald Kunt (1995) “On Agreement and Nominative Objects in Icelandic,” *Studies in Comparative Germanic Syntax*, ed. by Hubert Haider, Susan Olsen and Sten Vikner, 307–327, Kluwer, Dordrecht.
- Ura, Hiroyuki (2000) *Checking Theory and Grammatical Functions in Universal Grammar*, Oxford University Press, Oxford.
- Ura, Hiroyuki (2005) “Peculiar Passives as Derived Predicates,” *Journal of the Society of English and American Literature*, 49, 279–288, Kwansai Gakuin University.
- Ushie, Kazuhiro (1995) “Chikakudoshihobun-to Heikoteki Tajukozo (Complements of Perception Verbs and Parallel Structures),” *Hasegawa Kinsuke Kyoju Kanreki Kinen Rombunshu* (Essays in Linguistics and Philology Presented to Professor Kinsuke Hasegawa on the Occasion of His Sixtieth Birthday), ed. by Akira Baba, 293–310, Kenkyusha, Tokyo.
- Yoshimoto, Mayumi (2008) “Hikakukobun-ni okeru Toikozo nitsuite (On the Coordinate Structure in Comparative Constructions),” *Machikaneyama Ronso* 42, 51–65, Osaka University.