

Title	Molecular genetic study on fatty acid biosynthesis and desaturation for <i>Hansenula polymorpha</i>
Author(s)	Sangwallek, Juthaporn
Citation	大阪大学, 2014, 博士論文
Version Type	VoR
URL	<a href="https://doi.org/10.18910/34465">https://doi.org/10.18910/34465</a>
rights	
Note	

*Osaka University Knowledge Archive : OUKA*

<https://ir.library.osaka-u.ac.jp/>

Osaka University

# Doctoral Dissertation

Molecular genetic study on fatty acid biosynthesis and desaturation for

*Hansenula polymorpha*

Juthaporn Sangwallek

January 2014

Graduate School of Engineering,

Osaka University

## Table of Contents

	Subject	Page
<b>Chapter 1:</b>	<b>General introduction</b>	<b>5</b>
1.1	Fatty acids and their biological roles	5
1.2	Natural and alternative sources of fatty acids	8
1.3	Yeast cell factories	11
1.4	Biosynthesis of fatty acids in yeast	13
1.5	<i>De novo</i> fatty acid biosynthesis in yeast	16
1.6	Fatty acid desaturation in yeast	18
1.7	Molecular genetics of fatty acid biosynthesis in the yeast <i>Hansenula polymorpha</i>	20
1.8	Objectives of the study	21
<b>Chapter 2:</b>	<b>Ketoacyl synthase is a major determinant for fatty acyl chain length in <i>Saccharomyces cerevisiae</i></b>	<b>23</b>
2.1	Introduction	23
2.2	Materials and Methods	25
2.2.1	Yeast strains and culture conditions	25
2.2.2	Biochemical and genetic procedures	26
2.2.3	Preparation of <i>HpFAS1</i> and <i>HpFAS2</i> replacement cassettes	28
2.2.4	Construction and structural verification of single <i>HpFAS1</i> , <i>HpFAS2</i> and double <i>HpFAS1 HpFAS2</i> subunit replacement	30

2.2.5	Construction of <i>ScFAS2-PPT</i> domain-specific disruptant and <i>HpFAS2-PPT</i> replacement strain	32
2.2.6	Construction of chimeric <i>HpFAS2-KS PPT</i>	34
2.2.7	Fatty acid analysis	36
2.2.8	Structure modeling	37
<b>2.3</b>	<b>Results</b>	<b>37</b>
2.3.1	Both <i>HpFAS1</i> and <i>HpFAS2</i> functionally replace <i>ScFAS1</i> and <i>ScFAS2</i> in <i>S. cerevisiae</i>	37
2.3.2	Replacement of Fas2 ( $\alpha$ subunit) causes drastic change in C16/C18 ratio	40
2.3.3	KS domain in Fas2 plays a major role in fatty acyl chain length determination	41
2.3.4	Both <i>HpFAS</i> replacement strains are sensitive to high ethanol and high growth temperature	43
<b>2.4</b>	<b>Discussion</b>	<b>43</b>
<b>2.5</b>	<b>Summary</b>	<b>47</b>
<b>Chapter 3:</b>	<b>Cloning and functional analysis of <i>HpFAD2</i> and <i>HpFAD3</i> genes encoding <math>\Delta</math>12- and <math>\Delta</math>15-fatty acid desaturases in <i>Hansenula polymorpha</i></b>	<b>48</b>
<b>3.1</b>	<b>Introduction</b>	<b>48</b>
<b>3.2</b>	<b>Materials and Methods</b>	<b>49</b>
3.2.1	Yeast strains and culture conditions	49
3.2.2	Genetic and biochemical procedures	51

3.2.3	Cloning of <i>HpFAD2</i> and <i>HpFAD3</i>	52
3.2.4	Disruption of <i>HpFAD2</i> and <i>HpFAD3</i>	53
3.2.5	Heterologous expression of <i>HpFAD2</i> and <i>HpFAD3</i> in <i>S. cerevisiae</i>	54
3.2.6	RNA isolation, cDNA preparation, and quantitative real-time PCR	55
3.2.7	Fatty acid profile analysis	55
<b>3.3</b>	<b>Results</b>	<b>56</b>
3.3.1	Isolation of the <i>HpFAD2</i> and <i>HpFAD3</i> genes	56
3.3.2	Identification of <i>HpFAD2</i> and <i>HpFAD3</i> genes	57
3.3.3	Functional characterization of <i>HpFAD2</i> and <i>HpFAD3</i>	60
3.3.4	Heterologous expression of <i>HpFAD2</i> and <i>HpFAD3</i> genes in <i>S. cerevisiae</i>	62
3.3.5	Identification of promoter regions of <i>HpFAD2</i> and <i>HpFAD3</i> genes	64
3.3.6	Effect of low oxygen and exogenous fatty acids on <i>HpFAD2</i> and <i>HpFAD3</i> transcription	65
<b>3.4</b>	<b>Discussion</b>	<b>67</b>
<b>3.5</b>	<b>Summary</b>	<b>70</b>
<b>Chapter 4:</b>	<b>General discussion</b>	<b>72</b>
	References	78
	List of publications	93
	Acknowledgements	94

## Chapter 1

### General introduction

Fatty acids are essential components of virtually all cells and they fulfill a variety of cellular functions: storage materials for energy, major component of cell membrane, and signaling molecules. Since the yeast *Saccharomyces cerevisiae* and *Hansenula polymorpha* do not typically feed on fatty acids, cellular function and growth basically rely on endogenous biosynthesis. All cellular fatty acids are obtained from – fatty acid synthesis, elongation and desaturation – to ensure proper fatty acid composition and homeostasis for viability and functionalities of cells.

#### 1.1 Fatty acids and their biological roles

According to Rangan and Smith (2002), fatty acids are hydrocarbon chains with an aliphatic tail possessing a carboxyl group at one end. Most fatty acids are straight-chain compounds with an even number of carbon atoms. Fatty acyl chain lengths are from 2 to 80 carbons theoretically, but commonly found in the 12 to 24 carbon atoms in nature. Considering their chain length, fatty acids are divided into four classes: chain lengths of 2 to 6 are called short-chain, 8 to 10 are called medium-chain, and 12-18 are called long-chain, and 20-24 are called very long-chain fatty acids. Fatty acids can also be grouped into two types depending on their saturation: saturated and unsaturated fatty acids, although there can be additional functional groups as well such as hydroxyl, epoxy, acetylenic and so on, which also play roles in their conformation and function.

Saturated fatty acids have no carbon-carbon double bonds while the unsaturated fatty acids typically have one to six double bonds.

Basically, we have defined fatty acids using the following parameters: number of carbons, number of double bonds and the position of the double bonds. The number of carbons and the number of double bonds are denoted by two numbers separated by a colon (e.g., C20:4). The number before the colon denotes the number of carbon atoms (normally even) and the number following the colon refers to the numbers of double bonds. Since bond position and orientation are also important contributors to the physiological properties of fatty acids, additional naming conventions are added. The delta ( $\Delta$ ) positions are carbons counted from the carboxyl end of the fatty acid, while the omega ( $\omega$ ) positions are counted back from the terminal methyl end. The position of an individual double bond, or the specificity of an enzyme inserting it, is assigned using the delta ( $\Delta$ ) nomenclature in this thesis.

There are intrinsic properties of fatty acids in multiple ways. First, fatty acids provide an ideal form to store metabolic energy: the energy contained in the C-C bonds can be efficiently released by  $\beta$ -oxidation (Schulz 2008), a reaction formally equivalent to the reverse of fatty acid biosynthesis. As an efficient energy storage molecule in lipid droplets in eukaryotic cells, fatty acids were found as components of triacylglycerols and sterol esters. Second, the hydrophobic nature of acyl chains creates the force to establish membrane bilayer structures that are the basis of subcellular compartmentalization, which is a key role of fatty acids in any biological systems (Dowhan et al. 2008). In eukaryotic cells, the lipid bilayer of cell membrane is mostly composed of glycerophospholipids, in which the fatty acids are acylated to a glycerol moiety on carbons sn-1 and sn-2 positions and a polar head group is linked to sn-3

position through a negatively charged phosphate group. The phosphate group makes head of the glycerophospholipid hydrophilic while the fatty acid tail is hydrophobic. The glycerophospholipids are therefore amphipathic, having a polar end and a non-polar end. When glycerophospholipids are in the aqueous environment, they arrange themselves into lipid bilayers that exclude water molecules from the hydrophobic tails whereas keeping the hydrophilic heads in contact with the aqueous environment. Cellular membrane must be a dynamic structure when the cell grows under different environmental conditions in order to maintain fluidity of the cell membrane. Fatty acyl chain length and degree of unsaturation are therefore the key factors of fatty acid composition in any cells to maintain membrane fluidity. Saturated fatty acids, being straight chains, tend to pack closely together and would result in a membrane that is relatively solid at low temperatures, seriously impacting membrane fluidity and therefore survival of cells. Where a more loosely packed membrane structure is advantageous, the rigidity of lengthy saturated acyl chains can be countered by introducing double bonds. In unsaturated fatty acids, introduced double bonds result in bending of fatty acid chain from linearity of the saturated chain. Resulting Van der Waals forces increase the distance between chains, thereby decreasing chain-to-chain interaction, and accordingly decreasing membrane rigidity and melting point. Fatty acids are therefore essential for determining membrane structures and functions, in terms of regulating mobility, function of embedded proteins and affecting fluidity of phospholipid bilayer (Haucke and Di Paolo 2007). Third, specific fatty acids, especially polyunsaturated fatty acids (PUFAs), serve as precursors of biologically more active compounds such as eicosanoids, and may thus harbor signaling functions (Tapiero et al. 2002; Das 2006a). In mammals, eicosanoids, such as prostaglandins, leukotrienes, and



thromboxanes, mediate fever, inflammations, vasodilatation, blood pressure, clotting, pain, neurotransmission, and modulation of cholesterol metabolism (Funk 2001). PUFAs are therefore essential for maintaining health in humans and also are required for normal development and function of our body. Many PUFAs are so-called essential fatty acids literally because we cannot produce them and therefore need to obtain them from diet. The essential fatty acids, for instance, well-known  $\omega$ -6 fatty acid arachidonic acid (ARA, C20:4) and  $\omega$ -3 fatty acid docosahexaenoic acid (DHA, C22:6), are required fatty acids found in brain tissues (Riediger et al. 2009). They are also important dietary nutrients for neonatal babies owing to their involvement in the development of neural and retina functions (Das 2006b; Riediger et al. 2009).

## **1.2 Natural and alternative sources of fatty acids**

Fatty acids serve a variety of functions in living organisms and more importantly they play a key role in human health and nutrition, including neonatal retinal and brain development, as well as cardiovascular health and disease prevention as mentioned (Lauritzen et al. 2001; Riediger et al. 2009; Russo 2009). Numerous findings that dietary supplementation of PUFAs, such as  $\omega$ -6 fatty acids: [ $\gamma$ -linolenic acid (GLA, C18:3), and ARA]; and  $\omega$ -3 fatty acids: [eicosapentaenoic acid (EPA, C20:5), and DHA], significantly alleviates the symptoms of many chronic disease have attracted a great interest of general public and food manufactures. Although PUFAs have profound effects on human health, humans are incapable of synthesizing adequate essential PUFAs, therefore they must be obtained from natural dietary sources (Russo, 2009). However, human body can also synthesize some essential fatty acids only if

precursors linoleic acid (LA, C18:2) and  $\alpha$ -linolenic acid (ALA, C18:3) are available (Venegas-Calerón et al. 2010).

The traditional sources of PUFAs, especially  $\omega$ -3 fatty acids, to date are fish oils. However, due to the expansion of marine pollution, fish hauls are decreasing. The source also contains higher toxic impurities such as mercury, dioxins, and polychlorinated biphenyls, which must be removed (Certik and Shimizu 1999; Hooper et al. 2006) because consumption of these toxicants has been reported to lead to increased risk of cancer and neurological damage (Hooper et al. 2006). There are also large variations in the quality of fish oils as well depending on many factors such as

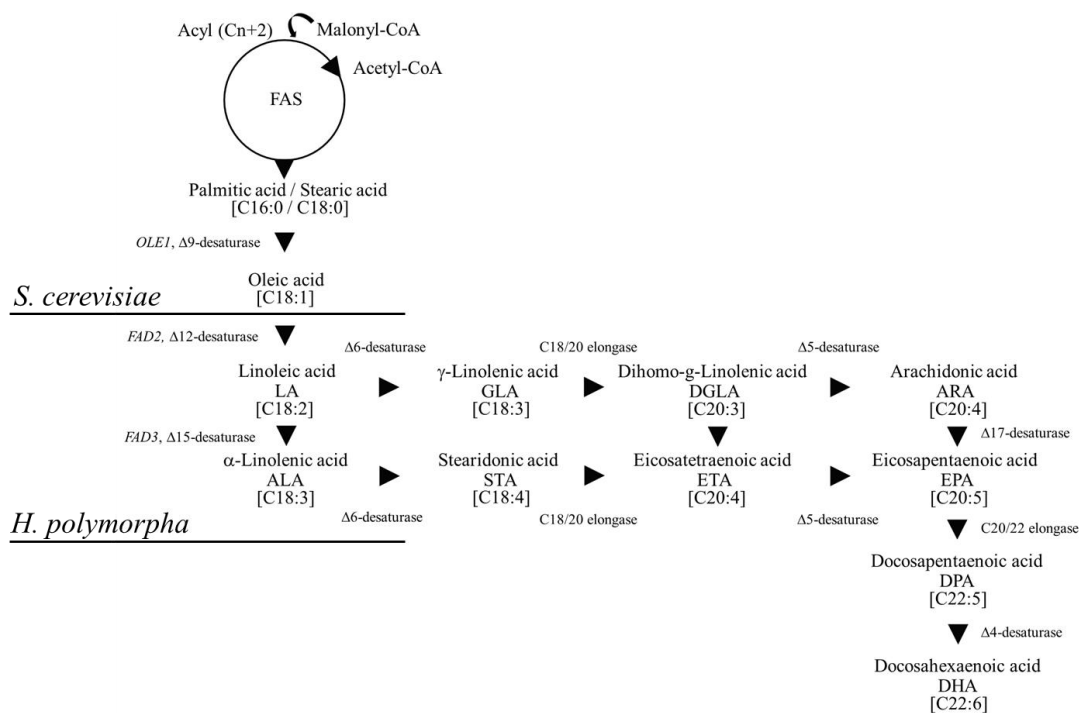

**Fig. 1** Schematic representation of biosynthetic pathway of very long chain polyunsaturated fatty acids (VLC-PUFAs). The route for synthesis of arachidonic acid (ARA), eicosapentaenoic acid (EPA), and docosahexaenoic acid (DHA) are shown, as mediated by the consecutive action of desaturases and elongases. The conventional yeast *S. cerevisiae* can produce fatty acid products upto oleic acid, while the non-conventional yeast *H. polymorpha* is able to produce linoleic acid (LA) and  $\alpha$ -linolenic acid (ALA) in addition to monounsaturated fatty acids (MUFAs). Adapted from Venegas-Calerón et al. 2010

types of fish, climate and geography (Certik and Shimizu 1999; Racine and Deckelbaum 2007; Hossain 2011). In addition to fish oil, flaxseed, canola and walnuts are also dietary sources of essential fatty acids, but indeed contain mainly  $\alpha$ -linolenic acid with little EPA and DHA (Covington 2004).

When the natural sources of fatty acids are very limited, it is therefore highly desirable to produce PUFAs from alternative sources that are more economical, easy to handle, and sustainable through genetic engineering techniques. One possible option that is possible is to modify oil-seed crops by genetic engineering to produce PUFAs (Napier and Sayanova 2005). In fact, no oil-seed species produces such products naturally, so they are needed to be genetically engineered for the capacity to synthesize these fatty acids in agronomically viable oil-seed species. As a successful development of transgenic plant for oil production, Robert et al. (2005) have reported for the first time the synthesis of DHA, along with its precursor EFA and  $\omega$ -6 PUFA (ARA) in seed oils of *Arabidopsis thaliana* by expressing a set of genes encoding the fatty acid elongation and desaturation enzymes required for the synthesis of PUFA from their C18 PUFA precursors such as C18:2 and  $\alpha$ C18:3 (Fig. 1). In another study of a breakthrough in production of essential fatty acids in plant, a set of elongase and desaturase genes from three different species, *Isochrysis galbana*, *Euglena gracilis* and *Mortierella alpina*, were expressed in *A. thaliana* (Qi et al. 2004). The dietary supplement of most modern societies in the 20<sup>th</sup> century is derived from plants, thereby giving us relatively low  $\omega$ -3 PUFAs with a concomitantly increased level of  $\omega$ -6 PUFAs (Blasbalg et al. 2011) in our diet. Moreover, plants always require several right and strict conditions such as climate, geography and importantly duration of growth to have a considerable amount of fatty acids. To solve the problem of inadequacy and quantity,

there has been much interest in single cell oils (SCO) as an alternative source of PUFAs (Ratledge 2004; Sakuradani and Shimizu 2009). A number of researches from a group of Prof. Shimizu in Kyoto University have shown that the filamentous fungus *M. alpina* is nowadays one of the promising SCO sources for fatty acid production (Sakuradani and Shimizu 2009). Due to its simple and regulated lipogenesis and its intrinsic property to produce ARA, *M. alpina* has arisen to be not only an industrial strain for PUFA production but also a model for lipogenesis studies. The group generated a wide variety of mutants defective in desaturases to gain information on PUFA biosynthesis and clarified a whole picture of the biosynthesis in this fungus for industrial uses. Major potential producers for the industrial uses are ARA- and mead acid (C20:3)-producing mutants. The ARA-producing mutants could provide between 10-50% higher ARA in total fatty acids than that found in wild-type depending on growth conditions (Shimizu et al. 2003; Sakuradani et al. 2004). The mead acid-producing mutants at specific conditions were reported to be able to produce up to 91% higher mead acid in total fatty acids than that found in wild-type (Sakuradani et al. 2002). The EPA-producing mutants could produce only 3-4% higher EPA in total fatty acids when linseed oil was supplied into media (Shimizu et al. 1988; Shimizu et al. 1989).

### **1.3 Yeast cell factories**

Yeast cell has met both the demand for efficient large-scale production and criteria of safety and authenticity of released products and also whole cell yeast-based biocatalyst technology for efficient mass production of a variety of chemical and biological compounds (Pscheidt and Glieder 2008). Therefore, yeast cells potentially arise as an intriguing choice to be developed for the production of PUFA as well.

*Saccharomyces cerevisiae* has been adopted as an initial yeast system for the production of various FDA-approved biochemical and biopharmaceutical products such as hepatitis B surface antigen and insulin (Melmer 2005). Although *S. cerevisiae* is generally considered to be an excellent model organism owing to feasible and precise genetics, applicability of recombinant DNA technology, and abundant and accessible genetic data, the fatty acid content of *S. cerevisiae* is characteristically not suitable for use in the industrial production of fatty acids due to incapability to produce precursors of PUFAs. In addition, transformation of C18:2 and  $\alpha$ C18:3 precursors to their higher unsaturated derivatives require the activity of consecutive desaturation and elongation reactions (Vrinten et al. 2007; Ruiz-Lopez et al. 2012; Uemura 2012). As a result, in case of *S. cerevisiae* to produce the specific target fatty acid, most studies have developed heterologous co-expression systems in *S. cerevisiae* by introducing a number of fatty acid desaturase and elongase genes from various organisms in several combinations (Beaudoin et al. 2000; Parker-Barnes et al. 2000; Domergue et al. 2002; Domergue et al. 2003; Meyer et al. 2004; Kainou et al. 2006; Li et al. 2011). Nevertheless, in all such studies, it is necessary to supply fatty acid precursors into the growth medium in order to produce the desired product. The highest fatty acid productivity attained so far without supplementation with fatty acid precursors (such as C18:1 or C18:2) in engineered *S. cerevisiae*, which must be cultivated at low temperature, gave C18:2 in a yield of only approximately 20% of total fatty acids (Yazawa et al. 2007).

Meanwhile, alternative non-conventional yeast such as *Hansenula polymorpha* has emerged. *H. polymorpha* has circumvented some drawbacks of *S. cerevisiae* by offering considerable advantages of specific abilities to expense cheap carbon source (methanol), to assimilate nitrate, to produce foreign proteins under the control of strong

constitutive or inducible promoter derived from the methanol metabolism pathway, and moreover to survive at high growth temperature and to tolerate various environmental conditions (Kang and Gellissen 2005). There have been many reports regarding the production of various recombinant proteins and biopharmaceutical products using *H. polymorpha* as an approved versatile cell factory (Dijk et al. 2000; Gellissen et al. 2005; Celik and Calik 2012). Many companies have developed *Hansenula* technology to enhance the productivity of recombinant products as well as process development. For instance, Crucell (Leiden, The Netherlands) has established well-known therapeutic vaccine against Hepatitis B under the trade name Hepavax-Gene®. Rhein Biotech (Maastricht, The Netherlands) has created Reiferon, vaccine against Hepatitis C. Besides, ARTES (Langenfeld, Germany) has innovatively applied *Hansenula* platform from bench to market. Considering that *H. polymorpha* is able to intrinsically produce LA and ALA, the bottleneck in the production of downstream PUFAs, we have shifted to the development of *H. polymorpha* cells as a much more efficient organism for the production of C18:2 and  $\alpha$ C18:3 precursors.

#### **1.4 Biosynthesis of fatty acids in yeast**

Biosynthesis of fatty acids begins with a 2-carbon chain from acetyl-CoA that enters iterative cycles of the fatty acid synthase (Fas) system, which extends the chain by two carbons per cycle by the addition of an acetyl group from malonyl-CoA. This system provides the bulk of cellular long-chain saturated fatty acid products (LCSFA, C12:0-C18:0). Each saturated fatty acid product from Fas can be further elongated by three elongase (Elo) enzymes: namely, Elo1, which elongates C14 fatty acids to C16

fatty acids; Elo2, which elongates C16/C18 fatty acids to C22/C24; and Elo3, which elongates C22/C24 fatty acids to C26 fatty acids (Tehlivets et al. 2007).

Unsaturated fatty acids can be produced by the introduction of double bonds into fatty acyl chains by desaturase enzymes. In eukaryotic cells, a double bond is primarily introduced at the  $\Delta 9$  position of saturated fatty acid products such as palmitic acid (C16:0) and stearic acid (C18:0) by the activity of  $\Delta 9$ -fatty acid desaturase (Ole1). *S. cerevisiae* has only one  $\Delta 9$ -fatty acid desaturase (Ole1); therefore, the fatty acid products from desaturation found in *S. cerevisiae* are mono-unsaturated fatty acids (MUFAs), mainly palmitoleic (C16:1) and oleic acids (C18:1) (Uemura 2012). Other yeasts, filamentous fungi and higher plants, however, are able to synthesize several poly-unsaturated fatty acids (PUFAs) including di-unsaturated fatty acids such as linoleic acid (LA, C18:2) and tri-unsaturated fatty acids such as  $\alpha$ -linoleic acid (ALA,  $\alpha$ C18:3), in addition to mono-unsaturated fatty acids. Di- and tri-unsaturated fatty acids are derived from the introduction of second and subsequently third double bonds via  $\Delta 12$ - and  $\Delta 15$ -fatty acid desaturase enzymes, respectively (Uemura 2012 and Martin et al. 2007). The relative ratio of chain lengths and the degree of unsaturation of these fatty acids vary widely depending on the yeast species (Table 1). In this study, I have focused on different fatty acid profile between two yeast species, *S. cerevisiae* and *H. polymorpha*. *S. cerevisiae* primarily produces saturated and monounsaturated fatty acids of C16 and C18 fatty acids because it contains only one fatty acid desaturase, a  $\Delta 9$ -fatty acid desaturase (Ole1), which is capable of producing monounsaturated palmitoleic acid (C16:1) and oleic acid (C18:1). *H. polymorpha*, however, oleic acid (C18:1) is subsequently desaturated to LA by introducing to LA the second double bond

**Table 1** Fatty acid composition of a variety of yeast species

Yeast Species	Fatty acid composition (mol%)										References
	12:0	14:0	16:0	16:1	18:0	18:1	18:2	18:3	Others	C16/C18	
<i>Candida albicans</i>	ND	ND	15.4	13.4	3.3	34.7	26.6	ND	3.0	0.5	Menyawati et al. 2000
<i>C. glabrata</i>	ND	ND	9.0	50.5	4.7	30.0	ND	ND	2.6	1.7	Menyawati et al. 2000
<i>Cryptococcus neoformans</i>	ND	ND	15.3	ND	4.5	37.5	41.8	ND	1.9	0.2	Menyawati et al. 2000
<i>Filobasidiella neoformans</i>	ND	ND	18.0	ND	3.0	46.0	28.0	ND	5.0	0.2	Moss et al. 1982
<i>Hansenula polymorpha</i>	ND	1.0	22.0	1.4	2.6	44.0	25.7	1.3	1.8	0.3	Wongsumpanchai et al. 2004
<i>Kluyveromyces lactis</i>	ND	0.8	10.9	31.3	3.6	23.7	21.4	5.1	ND	0.8	Cottrell et al. 1985
<i>Pichia pastoris</i>	ND	ND	12.3	14.8	ND	40.9	23.6	7.7	0.7	0.4	Halasz and Lasztity 1991
<i>Saccharomyces cerevisiae</i>	ND	ND	11.1	55.3	1.6	25.0	ND	ND	6.5	2.5	Menyawati et al. 2000
<i>Schizosaccharomyces pombe</i>	ND	1.1	3.5	22.8	ND	70.4	ND	ND	2.2	0.4	Johnson and Brown 1972
<i>Torulopsis glabrata</i>	ND	ND	2.0	26.0	5.0	63.0	ND	ND	4.0	0.4	Moss et al. 1982
<i>Yarrowia lipolytica</i>	ND	ND	12.0	10.0	2.0	46.0	20.0	ND	10.0	0.3	Moss et al. 1982
<i>S. kluyveri</i>	ND	0.5	14.1	23.9	2.5	21.9	21.3	15.8	ND	0.6	Oura et al. 2006



at the  $\Delta 12$  position by a  $\Delta 12$ -fatty acid desaturase and then making ALA by a  $\Delta 15$ -fatty acid desaturase, as well as other yeast species like *S. kluyveri*, *Kluyveromyces lactis*, *Candida albicans* and *C. tropicalis* (Watanabe et al. 2004; Oura and Kajiwara 2004; Kainou et al. 2006).

### 1.5 *De novo* fatty acid biosynthesis

Fatty acid synthase (Fas) functions in the *de novo* synthesis of long-chain saturated fatty acid, catalyzing cycles of multistep reactions conserved among a wide variety of organisms. Even though Fas enzymes trigger widely conserved biochemical reactions, they have their own fundamentally different architectures and can be grouped into two types depending on their organization (Schweizer and Hofmann 2004). Fas type I is a highly organized multifunctional enzyme complex that contains all catalytic units of the cyclic biosynthetic reaction as discrete domains either on a single subunit ( $\alpha$ ):-  $\alpha_2$  homodimers in vertebrates or two distinct polypeptide subunits ( $\alpha$  and  $\beta$ ):-  $\alpha_6\beta_6$  dodecamers in fungi (Jenni et al. 2006). In contrast, type II Fas, comprising of some bacterial, plant, mammalian and mitochondrial Fas, are discrete proteins (White et al. 2005; Maier et al. 2008).

Yeast Fas, a member of fungal Fas type I family, is a mega-multifunctional 2.6-MDa heterododecameric enzyme complex comprised of two distinct protein subunits,  $\alpha_6$  and  $\beta_6$  encoded by *FAS2* and *FAS1*, respectively, harboring eight functional domains necessary for all enzymatic steps in the *de novo* biosynthesis of fatty acids: activation, priming, multiple cycles of elongation and termination (Fig. 2). All these reactions occur in a limited space inside the  $\alpha_6\beta_6$  complex. The  $\alpha$  subunit (Fas2) contains four

domains, - acyl carrier protein (ACP), ketoacyl reductase (KR), ketoacyl synthase (KS) and phosphopantetheinyl transferase (PPT), while the  $\beta$  subunit (Fas1) comprises 4

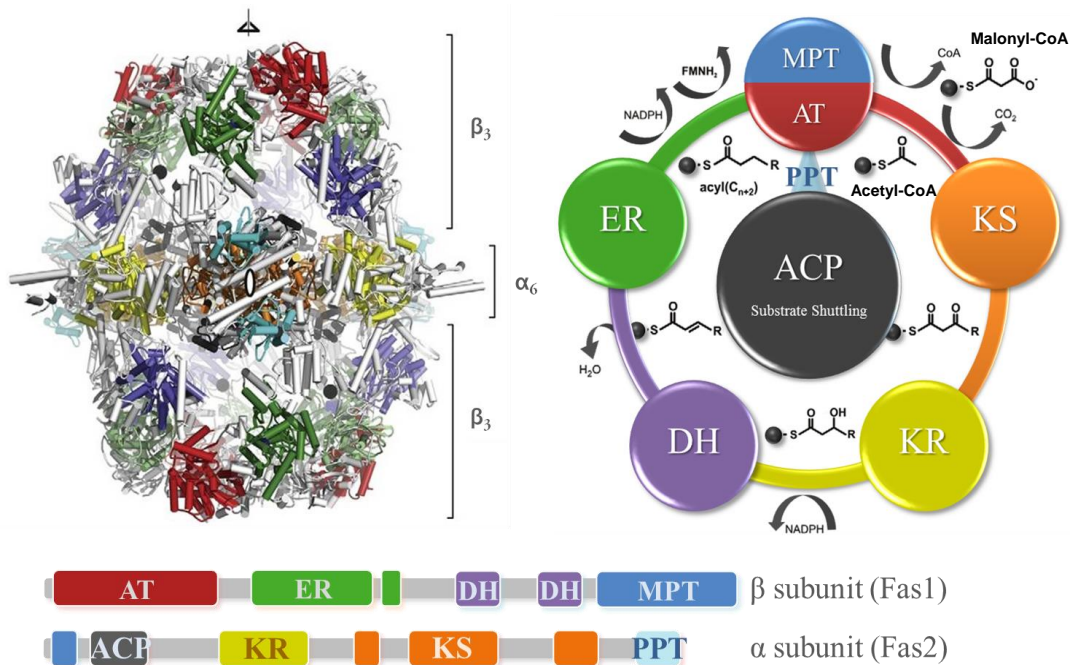

**Fig. 2** Yeast fatty acid synthase (Yeast Fas) (A) Crystal structure of yeast Fas. The fungal Fas folds into an  $\alpha_6\beta_6$  heterododecamer consisting of a hexameric central wheel formed by six  $\alpha$ -chains, which is capped on both sides by two domes formed by  $\beta$ -chains trimers. (B) Iterative catalytic cycle of yeast Fas. Acetyl-CoA serves as a starter substrate for iterative stepwise elongation by two carbon units donated from the elongating substrate malonyl-CoA in a decarboxylative condensation. Substrate loading is catalyzed by AT and MPT. KS catalyzes the decarboxylative condensation and KR, DH, and ER are modifying the beta-carbon position. ACP shuttles the saturated fatty acyl chain elongated by two carbon atoms back to KS, where it serves as primer for the next reaction cycle. (C) Linear domain organization of yeast Fas, adapted from Leibundgut et al. 2008.

domains, - acetyl transferase (AT), enoyl reductase (ER), dehydratase (DH) and malonyl/palmitoyl transferase (MPT).

The crystal structure of yeast Fas has given insights into how multi-enzymatic activities work together to fulfill iterative cycles of *de novo* fatty acid biosynthesis. The synthesis begins with the transfer of acetyl primer and malonyl elongation substrates from their coenzyme A (CoA) forms to a sulfhydryl group on ACP by the functions of

AT and MPT and further condensed to acetoacetyl-ACP by KS. Acetoacetyl-ACP is then reduced by KR, dehydrated by DH and reduced again by ER, resulting in a growing saturated fatty acyl-ACP inside the cavity of the Fas complex. In each iterative cycle, the growing fatty acyl chain is elongated by two carbon units until the fatty acids reach lengths of 16 or 18 carbons, which are back-transferred into CoA forms by MPT (Jenni et al. 2006, 2007; Leibundgut et al. 2007; Lomakin et al. 2007; Johansson et al. 2009; Gipson et al. 2010). However, the exact mechanism that determines the final length of fatty acids in yeast remains elusive (Riezman 2007; Leibundgut et al. 2008).

## **1.6 Fatty acid desaturation**

Fatty acid desaturases (Fads) are the enzymes that catalyze the insertion of a double bond into fatty acids, resulting in more unsaturated forms. The common fatty acid desaturase family consists of membrane-bound enzymes (Johnson and van Waes 1999). Integral membrane proteins are anchored in the membrane by hydrophobic stretches of amino acids referred to as a transmembrane-spanning domain (TMD). Although investigation of these desaturases by traditional chemical approaches has been limited due to the difficulty of solubility and therefore purification while retaining enzyme activity, two members of this membrane-bound desaturase family have been extensively studied and characterized from yeasts and plants (Vance and Vance 2002). The first member is acyl-lipid desaturases. This group of enzymes is found in plants and cyanobacteria. They use fatty acyl-lipids as substrates and require either ferredoxin or cytochrome *b5* as an electron donor. Another member is acyl-CoA desaturases which commonly exist in yeasts, fungi as well as mammals. They use fatty acyl-CoAs as substrates and use only cytochrome *b5* as an electron donor.

Considering in both yeast species of interest in this study, *S. cerevisiae* and *H. polymorpha* can synthesize monounsaturated fatty acids (MUFAs), C16:1 and C18:1 by introducing the first double bond into saturated fatty acids by the function of  $\Delta^9$ -fatty acid desaturase (Ole1). Disruption of *OLE1* gene results in the auxotroph for unsaturated fatty acids, confirming the essential role of Ole1 in the fatty acid desaturation reaction (Zhang et al. 1999). Two important endoplasmic reticulum-bound fatty acid desaturases, which will be further mentioned in the whole of Chapter 4 of this study, are  $\Delta^{12}$ - (Fad2) and  $\Delta^{15}$ - (Fad3) fatty acid desaturases. Previously, there are a number of studies regarding the identification of genes encoding  $\Delta^{12}$ - and  $\Delta^{15}$ -fatty acid desaturases; for instance, in case of *FAD2*, there have been reported in *Arabidopsis* (Okuley et al. 1994), *M. alpina* (Huang et al. 1999; Sakuradani et al. 1999), *Mucor rouxii* (Passorn et al. 1999) and *Aspergillus nidulans* (Calvo et al. 2001), and  $\Delta^{15}$ -fatty acid desaturase genes were isolated from *Arabidopsis* (Arondel et al. 1992; Yadav et al. 1993) and *M. alpina* (Sakuradani et al. 2005). Studies on the isolation of  $\Delta^{12}$ - and  $\Delta^{15}$ -fatty acid desaturase genes from yeasts are fewer. Previous reports on yeast fatty acid desaturases were *S. kluyveri* *FAD2* (Watanabe et al. 2004) and *FAD3* (Oura and Kajiwara 2004), and *K. lactis* *FAD2* and *FAD3* (Kainou et al. 2006).

As mentioned, animals cannot synthesize essential PUFAs (EPA, ARA and DHA) although we have  $\Delta^5$ - ,  $\Delta^6$ -fatty acid desaturases and C18/C20 elongases. This is because we lack their fatty acid precursors including LA and ALA. The production of LA and ALA requires  $\Delta^{12}$ - and  $\Delta^{15}$  fatty acid desaturases, which do not exist in animals. If we could have the precursors, we would be able to produce essential PUFAs regardless of dietary resources. In contrast, many plants, some fungi and also *H. polymorpha* are able to synthesize these fatty acid precursors, LA and ALA. *H.*

*polymorpha* is therefore thought to be an alternative producer for production of the precursors of the essential PUFAs.

### **1.7 Molecular genetics of fatty acid biosynthesis in *Hansenula polymorpha***

*H. polymorpha* is able to synthesize PUFAs and also shows ability for uptake and incorporation of exogenous MUFAs (Anamnart et al. 1998). Two genes involved in fatty acid biosynthesis in *H. polymorpha*, the fatty acid synthase genes; *HpFAS1* (Kaneko et al. 2003) and *HpFAS2* (Nakajima 2004), the  $\Delta^9$ -fatty acid desaturase gene (*HpOLE1*) (Anamnart et al. 1997; Lu et al. 2000), have been cloned and characterized in our laboratory. Disruption of *HpFAS1* leads the cells to be fatty acid-auxotroph. The *Hpfas1* disruptant could grow on nutrient media supplemented by 1mM C14:0 or C16:0, but not by C12:0, suggesting that fatty acid elongation systems from C14:0 to C16:0 and C16:0 to C18:0 exist, but not for C12:0 to C14:0 in this yeast, and C14:0 and C16:0 is indispensable for vegetative growth (Schweizer et al. 1978). Our laboratory has also identified for the first time the fatty acid elongase genes *HpELO1* and *HpELO2* (Prasitchoke et al. 2007a, Prasitchoke et al. 2007b). *HpELO1* was characterized as an ortholog of the *S. cerevisiae ELO3* that is involved in the elongation of very long chain fatty acids (VLCFAs). *Hpelol1* disruptant had a decrease in C24:0 and C26:0 with a compensatory increase in C22:0, indicating that *HpELO1* is involved in the elongation of VLCFAs, especially C24:0 (Prasitchoke et al. 2007a). *HpELO2* has been identified as a homolog of *HpELO1* gene. However, disruption of *HpELO2* led to an accumulation of C18:0 with a remarkable decrease in C20:0, suggesting that *HpELO2* is required for the elongation of C18:0 to VLCFAs (Prasitchoke et al. 2007b).

Regarding the study of fatty acid desaturation in *H. polymorpha*, *HpOLE1* functions instead of *S. cerevisiae* *OLE1* only by heterologous expression driven by glyceraldehyde-3-phosphate dehydrogenase promoter, but not by its own native promoter in *S. cerevisiae* cells (Lu et al. 2000). This suggested that *H. polymorpha*  $\Delta 9$ -fatty acid desaturase is compatible with the desaturation system of *S. cerevisiae*; however, transcriptional regulations at their promoters of the  $\Delta 9$ -fatty acid desaturase gene are potentially different, although transcriptional level of *HpOLE1* was observed to be repressed by the presence of excess C18:1 as well as that of *OLE1* in *S. cerevisiae* (Anamart et al. 1997). In addition to studies on the main flow of the fatty acid synthesis pathway, there has been reported also a successful production of GLA in *H. polymorpha* by introducing  $\Delta 6$ -fatty acid desaturase of *Mucor rouxii* (Laoteng et al. 2005).

## **1.8 Objectives of the study**

I aim at gaining more understanding in the characteristic of the fatty acid synthase and identification of more functional fatty acid desaturase genes for production of polyunsaturated fatty acids, thus allowing us to gain better understanding in the fatty acid biosynthesis in *H. polymorpha* and will be a gateway for further research in gene regulation and biological application.

In Chapter 1, I introduced the basic information about fatty acids, traditional sources and alternative sources of fatty acids and possibility of using yeast as a fatty acid cell factory, biosynthesis and desaturation of fatty acids in yeast, and recent molecular genetic studies of fatty acid biosynthesis in *H. polymorpha*. Chapter 2 uncovers more details in the characteristic of the *H. polymorpha* fatty acid synthase

collaborating with *S. cerevisiae* fatty acid synthase through the study of chimeric fatty acid synthase. Moreover, I could explain more precise domain of the yeast fatty acid synthase responsible for fatty acyl chain length and saturation. In Chapter 3, I described the cloning and functional analysis of two polyunsaturated fatty acid desaturase genes,  $\Delta$ 12- and  $\Delta$ 15-fatty acid desaturase genes, named *HpFAD2* and *HpFAD3*, involved in the productions of linoleic acid and  $\alpha$ -linolenic acid, respectively. Transcriptional repression of *HpFAD3*, but not *HpFAD2*, caused by the low oxygen conditions and exogenous unsaturated fatty acids were also described in this chapter. In Chapter 4, I summarized a significant breakthrough in this thesis and discussed a possibility of future experiments to discover more refined knowledge determining fatty acyl chain length from *de novo* biosynthesis and possible regulatory mechanisms on fatty acid desaturation in *H. polymorpha*.

## Chapter 2

### **Ketoacyl synthase domain is a major determinant for fatty acyl chain length in *Saccharomyces cerevisiae***

#### **2.1 Introduction**

The *de novo* biosynthesis in yeast reported by Jenni et al. (2007) and Lomakin et al. (2007) contains initiation, elongation, and termination steps. The initiation step is loading acyl primer so-called acetate from Coenzyme A (CoA) to a specific binding site on Fas by the Fas component enzyme acyltransferase (AT). The elongation involves a distinct set of multistep chemical reactions of enzyme-bound intermediates with several iterative cycles. Each cycle includes malonyl-transacylation from CoA to the enzyme by malonyl transferase condensation from CoA to the enzyme by malonyl palmitoyltransferase (MPT). Then, condensation of acyl-enzyme with enzyme-bound malonate to 3-ketoacyl-enzyme is carried out by 3-ketoacyl synthase (KS). Reduction of the 3-keto to 3-hydroxyacyl intermediate is done by ketoacyl reductase (KR). The 3-hydroxyacyl intermediate is dehydrated to 2, 3-trans-enoate by dehydratase (DH). Finally, the reduction of the enoate to the saturated acyl-enzyme is catalyzed by enoyl reductase (ER). At the end of the process, termination of fatty acyl chain elongation occurs by removing the products from acyl carrier protein (ACP), which is fatty acyl chain-shuttling domain, by the activity of MPT for transacylation of palmitate from the enzyme to CoA.

Fas employs one acetyl-CoA and seven or eight malonyl-CoA molecules to synthesize palmitic acid (C16:0) or stearic acid (C18:0) as the most abundant fatty acid



species in yeast. However, the fatty acid composition (e.g., ratio of chain length and degree of unsaturation) varies among species (Yazawa et al. 2009). *S. cerevisiae* Fas synthesizes more C16 than C18 fatty acids during vegetative growth, in contrast to most yeasts that produce polyunsaturated fatty acids (PUFA) such as *Candida albicans*, *Yarrowia lipolytica* and *Ogataea angusta* (*Hansenula polymorpha* in this study) which produce more C18 than C16 fatty acids (Menyawati et al. 2000; Wang et al. 2011; Wongsumpachai et al. 2004; Prasitchoke et al. 2007a). The C16/C18 ratio in *S. cerevisiae* is approximately 2.0-2.5 (Menyawati et al. 2000) whereas in *H. polymorpha*, it is about 0.2-0.3 (Wongsumpachai et al. 2004; Prasitchoke et al. 2007). This suggests that differences in Fas enzymes between *S. cerevisiae* and the PUFA-producing yeasts may account for the compositional differences.

The *FAS1* and *FAS2* genes were previously cloned from *S. cerevisiae* (Schweizer et al. 1986) and from PUFA-producing yeasts including *C. albicans* (Zhao and Cihlar 1994; Southard and Cihlar 1995), *Y. lipolytica* (Schweizer et al. 1988; Kotig et al. 1991) as well as *O. angusta* (*H. polymorpha*) from our laboratory (Kaneko et al. 2003). Although 62 and 67% amino acid sequence identity is shared between *S. cerevisiae* and the PUFA-producing yeasts for Fas1 and Fas2, respectively, the region or even Fas subunit responsible for the differences in C16/C18 ratios between these two types of yeast species is unknown.

Aiming at understanding mechanism by which Fas determines chain lengths of fatty acid products, I therefore investigated Fas structure-function relationship by creating chimeric genes combining hybrid FAS between *S. cerevisiae* and *H. polymorpha* and further chimeric genes within each subunits from two species. In this Chapter, I describe  $\alpha$  subunit or Fas2 plays a major role determining fatty acyl chain

length. In particular, KS domain in Fas2, but not ACP, KR or PPT domains, acts as a major determinant of fatty acyl chain length.

## 2.2 Materials and methods

### 2.2.1 Yeast strains and culture conditions

The *S. cerevisiae* and *H. polymorpha* strains in this Chapter are listed in Table 2.

**Table 2** Yeast strains used in this Chapter

Strain	Genotype and Remarks	Ref.
<i>Saccharomyces cerevisiae</i>		
SH8938	<i>MATa ura3-1 leu2-3,112 trp1 his3-11,15 ade2-1 Scfas1Δ::CgLEU2</i>	Our stock
SH8940	<i>MATa ura3-1 leu2-3,112 trp1 his3-11,15 ade2-1 Scfas2Δ::CgHIS3</i>	Our stock
SH8942	<i>MATa</i> : A replacement of <i>Scfas1Δ::CgLEU2</i> with <i>HpFAS1</i> in SH8938	This study
SH8943	<i>MATa</i> : A replacement of <i>Scfas1Δ::CgLEU2</i> with <i>HpFAS1</i> in SH8938	This study
SH8944	<i>MATa</i> : A replacement of <i>Scfas2Δ::CgHIS3</i> with <i>HpFAS2</i> in SH8940	This study
SH4848 (W303-1A)	<i>MATa ura3-1 leu2-3,112 trp1 his3-11,15 ade2-1</i>	Our stock
KYC1289	<i>MATa ura3-1 leu2-3,112 trp1 his3-11,15 ade2-1 Scfas1Δ::HpFAS1</i>	This study
KYC1290	<i>MATa ura3-1 leu2-3,112 trp1 his3-11,15 ade2-1 Scfas1Δ::HpFAS1</i>	This study
KYC1291	<i>MATa ura3-1 leu2-3,112 trp1 his3-11,15 ade2-1 Scfas2Δ::HpFAS2</i>	This study
KYC1292	<i>MATa ura3-1 leu2-3,112 trp1 his3-11,15 ade2-1 Scfas2Δ::HpFAS2</i>	This study
KYC1293	<i>MATa ura3-1 leu2-3,112 trp1 his3-11,15 ade2-1 Scfas1Δ::HpFAS1 Scfas2Δ::HpFAS2</i>	This study
KYC1294	<i>MATa ura3-1 leu2-3,112 trp1 his3-11,15 ade2-1 Scfas1Δ::HpFAS1 Scfas2Δ::HpFAS2</i>	This study
SH8948	<i>MATa ura3-1 leu2-3,112 trp1 his3-11,15 ade2-1 Scfas2-pptΔ::URA3</i>	This study
SH8953	<i>MATa ura3-1 leu2-3,112 trp1 his3-11,15 ade2-1 Scfas2-pptΔ::HpFAS2-PPT</i>	This study
SH8958	<i>MATa ura3-1 leu2-3,112 trp1 his3-11,15 ade2-1 Scfas2Δ::HpFAS2-KS PPT</i>	This study
<i>Hansenula polymorpha</i>		
H50-5C	<i>ura3-1 leu1-1</i>	Our stock

Cells were cultivated at 30 °C (*S. cerevisiae*) or 37 °C (*H. polymorpha*), unless otherwise noted, in rich media (YPAD): 1 % Bacto-yeast extract (BD Bioscience, Sparks, MD, USA); 2 % Bacto-peptone (BD); 2 % glucose and 0.02 % adenine. *S. cerevisiae* SH4848 (W303-1A) and *H. polymorpha* H50-5C strains were used to isolate the *ScFAS* and *HpFAS* genes.

*S. cerevisiae* *fas1* or *fas2* disruption mutants were grown in synthetic dextrose media (SD): 0.67% yeast nitrogen base w/o amino acids (BD) and 2% glucose supplemented with exogenous fatty acids, 1 mM each of myristic acid (C14:0) and palmitic acid (C16:0) (Wako) emulsified by 1% w/v of Brij58 (Sigma) and amino acids and nucleic acid bases. For plate culture, 2% agar were added.

### **2.2.2 Biochemical and genetic procedures**

Primers used in this Chapter are listed in Table 3. Nucleotide sequences shown in uppercase letters are from *S. cerevisiae*, while those indicated in lowercase letters are from *H. polymorpha*. DNA manipulations were performed in *E. coli* and yeasts using standard procedures (Sambrook et al. 1989). Restriction enzymes, PrimeSTAR Max<sup>®</sup> DNA polymerase (TAKARA Bio Inc.) and AmpliGold Taq polymerase (Perkin-Elmer, Boston, MA, USA) were used essentially according to the manufactures' recommendations. Southern analysis was performed using an ECL direct nucleic acid labeling and detection system (GE Healthcare). Yeast genomic DNA (10µg) was digested by appropriate restriction enzymes and then electrophoresed for 3 h at 50 V on a 0.8% agarose gel and subsequently transferred to a nylon filter (Hybond-N<sup>+</sup>; GE Healthcare) in 20X SSC by standard methods (Sambrook et al. 1989). Hybridization, washing and detection were performed using the ECL system. Genetic analysis

**Table 3** Primers used in this Chapter

<b>Primer</b>	<b>Sequence (5'→ 3')</b>
<i>Scfas1Δ::HpFAS1 construction</i>	
FAS1-IF	TGGCATTTTTGGCATACTTTTA
FAS1-IR	AATGAGCGAATAATAGAGCAGTTA
FAS1-IIF	TAACTGCTCTATTATTCGCTCATTatgtcgggtaataagaccg
FAS1-IIR	gatttgacagtgccttatcagt
FAS1-IIIFv.2	actgcatggcccgttgcgc
FAS1-IIIR	ACGGTTATATAATCACTTAAGAAAttatgctgactcgaatg
FAS1-IVFv.2	cattacgagtcagcataaTTTCTTAAGTGATTATATAACCGT
FAS1-IVRv.3	CATCTGCCCCGCCCTAGCGAG
<i>Scfas2Δ::HpFAS2 construction</i>	
FAS2-IFv.2	CGTTGAAGACGCTCAACTCGACGTAGA
FAS2-IR	AATGATGGTATTTCAATTGGTGTT
FAS2-IIF	ACCAATTGAAATACCATCATTatgaagccggagatcgaacaagaa
FAS2-IIRv.2	ttggaagtcgcatagccaccacaat
FAS2-IIIFv.2	ccaggtacggtgctgcgattctacgtag
FAS2-IIIR	AGGGACTACGTAGTGCTCTCTtcagaactctgatcgaaccgc
FAS2-IVF	AGAGAGCACTACGTAGTCCCTCTT
FAS2-IVRv.2	GCACTCGTCCACCTTCGCGATTTTTCT
<i>Structural verification</i>	
I-HpFAS1F	gggattgagaccaccatcctgacc
I-ScFAS1F	GGCGAGGGTAACGCACAATTGGTAG
I-FAS1-CommonR	CAGAAGCTCCACCAGGACCGAAGTC
I-FAS2-CommonF	CAATTTGCCTCTCCTGTGAGATGGA
I-HpFAS2R	atacatggatagcgcgctcctcctt
I-ScFAS2R	CGACGGGAGCTGGGGCTGTGCTGC
I-ScURA3F	TGCAGTACTCTGCGGGTGTA

**Table 3** Primers used in this Chapter (Continued)

Primer	Sequence (5'→ 3')
<i>Chimeric FAS2 construction</i>	
HpKS-3	TATGTCGCCAAGGTTAGTGCC
HpKS-4	GATGTAAGTGCCTTGCTTTGG
HpPPT-3	AAATAGAGAGAGACTACGTAGTCC
HpPPT-4	TTCCACGCGTCAATATGCCC
HpPPT-5	CCAAAGCAAGGACAGTTACATCCGACGGCCAGTGCCAAGC
HpPPT-6	GGACTACGTAGTGCTCTCTCTATTTCTGCAGGCATGCAAGCT
HpPPT-7	CCAAAGCAAGGACAGTTACATCagtgagttctcgacagaaacag
HpPPT-8	GGACTACGTAGTGCTCTCTCTATTTgaactctgatcgcaaccgc
HpACP-HpKR1v.2	TATAGGGCGAATTGGAGCTCATTTCTCTGGTCTGCAGGCC
HpACP-HpKR2v.2	CTGGGAAGTCCAGTTGAATGTTAGCccttggttgatctctgctttg
HpACP-HpKR3v.2	GCTAACATTCAACTGGACTTCCCAG
HpACP-HpKR4v.2	GGGAACAAAAGCTGGGTACCTCAGAGGCTAAAGTAAGGAAACGA
HpKS-HpPPT6v.2	cagatttgggaattcaaattcatgttagcTCTTGGTTGAATTTGACTTGAGC
HpKS-HpPPT7v.2	gctaacaatgaaattgaattcccaaatc

including yeast transformation, mating, sporulation and tetrad dissection were performed as described (Amberg et al. 2005).

### 2.2.3 Preparation of *HpFAS1* and *HpFAS2* replacement cassettes

To construct single *HpFAS1* and *HpFAS2* replacement strains, *HpFAS1* and *HpFAS2* replacement cassettes were each amplified as two DNA fragments: *ScFAS* promoter + first-half of *HpFAS* and second-half of *HpFAS* + *ScFAS* terminator in two PCRs (Fig. 3).

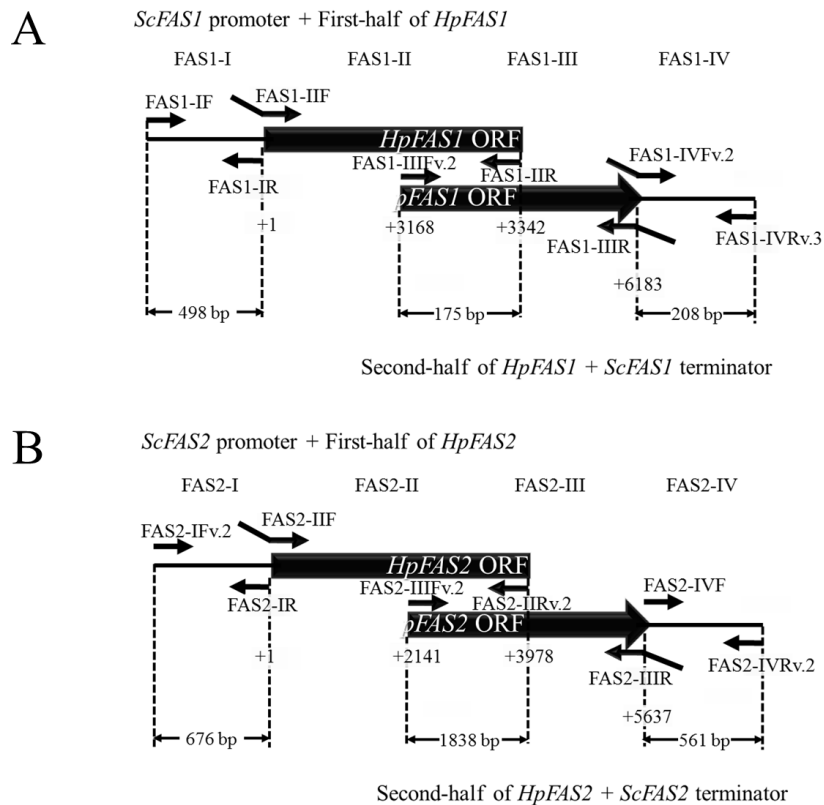

**Fig. 3** Construction of *HpFAS1* (A) and *HpFAS2* (B) subunit replacement cassettes. *HpFAS* replacement cassettes were amplified as two DNA fragments: *ScFAS* promoter + first-half of *HpFAS* and second-half of *HpFAS* + *ScFAS* terminator. In the first PCR, FAS DNA fragments I, II, III and IV (FAS1-I, FAS1-II, FAS1-III and FAS1-IV or FAS2-I, FAS2-II, FAS2-III and FAS2-IV designated collectively as FAS) were amplified separately, and subsequently, FAS-I and FAS-II, and FAS-III and FAS-IV were joined in the second PCR.

In the first PCR, FAS DNA fragments I, II, III and IV (FAS1-I, FAS1-II, FAS1-III and FAS1-IV and FAS2-I, FAS2-II, FAS2-III and FAS2-IV designated collectively as FAS) were amplified separately. In the second PCR, FAS-I and FAS-II, and FAS-III and FAS-IV DNA fragment were joined. Genomic DNA of *S. cerevisiae* SH4848 was used as a template to amplify FAS-I and FAS-IV, whereas plasmids harboring *HpFAS* ORF, pUC118-*HpFAS1* and pBS-*HpFAS2* (unpublished data) were used to generate FAS-II and FAS-III. Annealing temperatures of 60°C and 80°C were used to amplify the *ScFAS1* promoter + first-half of *HpFAS1* and the second-half of *HpFAS1* + *ScFAS1*

terminator, respectively, while 60°C and 63°C were used for the *ScFAS2* promoter + first-half of *HpFAS2* and the second-half of *HpFAS2* + *ScFAS2* terminator, respectively.

#### **2.2.4 Construction of single *HpFAS1*, *HpFAS2* and double *HpFAS1 HpFAS2* subunit gene replacement**

Fragments of the *ScFAS* promoter + first-half of *HpFAS* and the second-half of *HpFAS* + *ScFAS* terminator were introduced by transformation into *Scfas1*Δ (SH8938) or *Scfas2*Δ (SH8940) mutants to replace the *Scfas1*Δ or *Scfas2*Δ loci with the introduced cassettes by homologous recombination. Because the *Scfas1*Δ or *Scfas2*Δ loci were replaced with functional alleles (*HpFAS1* and *HpFAS2*), candidates were selected on YPAD without the fatty acid supplementation required by the parental strains. The single *HpFAS1*, *HpFAS2* and double *HpFAS1HpFAS2* replacement alleles were confirmed by PCR and Southern blotting. To verify the *HpFAS1* replacement, genomic DNA from the *HpFAS1* replacement candidate and *Scfas1*Δ::*CgLEU2* strain were digested with *Pst*I. Upstream fragment from the *HpFAS1* ORF and *CgLEU2* were used as probes (Fig. 4A). The correct *HpFAS1* replacement strain was expected to generate a 6.2 kb band, while the *Scfas1*Δ::*CgLEU2* strain was expected to generate a 5.1 kb band as observed in Fig. 4A (right panel). In the case of the *HpFAS2* replacement strains, genomic DNA from the *HpFAS2* replacement candidates and *Scfas2*Δ::*CgHIS3* strain whose *ScFAS2* was previously disrupted with *CgHIS3* were digested separately with *Eco*RI and *Pst*I. The downstream segment of *ScFAS2* ORF was used as a probe (Fig. 4B). The *HpFAS2* replacement candidates were expected to generate 1.3- and 3.1-kb bands, respectively, whereas 1.1- and 2.1-kb bands were expected from *Eco*RI and *Pst*I digestion, respectively, of genomic DNA from the *Scfas2*Δ::*CgHIS3* strain. Southern

analysis confirmed that the *HpFAS2* locus was correctly replaced at the *Scfas2Δ::CgHIS3* locus (Fig. 4B, right panel). The *HpFAS1* replacement strains in *MATa* and *MATα* backgrounds were designated SH8942 and SH8943, respectively, whereas the *HpFAS2* replacement strain in *MATa* background was named SH8944.

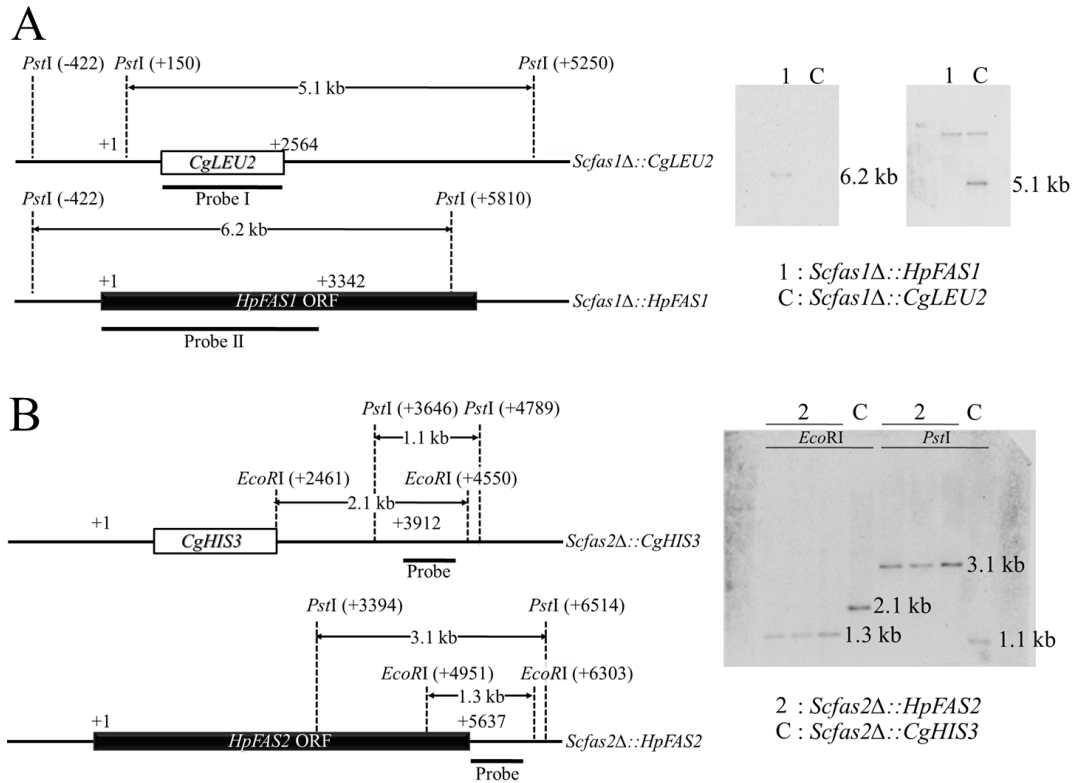

**Fig. 4** Southern hybridization analysis for structural verification of the *HpFAS1* replacement strain (A) and *HpFAS2* replacement strains (B). In order to confirm the *HpFAS1* replacement, an upstream segment of the *HpFAS1* ORF, and *CgLEU2* were used as probes. *PstI*-digestion of genomic DNA from the *HpFAS1* replacement candidate yielded a 6.2 kb band, while *Scfas1Δ::CgLEU2* yielded a 5.1 kb band. To verify the *HpFAS2* replacement, a 561-bp downstream segment of *Scfas2* ORF was used as a probe. *EcoRI* and *PstI*-digestion of genomic DNA from the *HpFAS2* replacement candidates generated bands of 3.1 and 1.3 kb in size, respectively, while generating 2.1- and 1.1-kb bands for *Scfas2Δ::CgHIS3*.

Double *HpFAS1 HpFAS2* replacement strains were constructed by crossing SH8943 with SH8944 which are single *HpFAS1* and *HpFAS2* replacement strains, respectively, followed by tetrad dissection. The tetrad segregants were grown on YPAD



without fatty acid supplementation. Double *HpFAS1 HpFAS2* replacement strains were confirmed by PCR using the primers noted in Table 3. I-HpFAS1F and I-ScFAS1F forward primers with I-FAS1-CommonR, a common reverse primer were used to distinguish *HpFAS1* from *ScFAS1*, respectively. The equivalent analysis of the *FAS2* locus was performed using I-FAS2-CommonF, a common forward primer with I-HpFAS2R and I-ScFAS2R reverse primers.

### **2.2.5 Construction of *ScFAS2-PPT* domain-specific disruptant and *HpFAS2-PPT* replacement strain**

To disrupt the *ScFAS2-PPT* domain, we designed a fusion construct to specifically replace the *ScFAS2-PPT* domain (Fig. 5A) with *S. cerevisiae URA3* (*ScURA3*). In the first-round PCR, genomic DNA from *S. cerevisiae* SH4848 was used as a template to amplify 219 bp-upstream and 233 bp-downstream of the *ScFAS2-PPT* domain using a pair of forward and reverse primers: HpKS-3 and HpKS-4, and HpPPT-3 and HpPPT-4, respectively (Table 3). To generate *ScURA3* having 25 bp-flanking regions upstream and downstream of the *ScFAS2-PPT* domain, a pair of forward and reverse primers, HpPPT-5 and HpPPT-6, were used with plasmid BYP4904 carrying *ScURA3* ([http://yeast.lab.nig.ac.jp/nig/index\\_en.html](http://yeast.lab.nig.ac.jp/nig/index_en.html)) as template. A second-round PCR was performed to assemble all products from the first-round PCR to complete construction of the *ScFAS2-PPT* domain-specific disruption cassette (Fig. 5B). *S. cerevisiae* SH4848 was then transformed with the cassette. *Scfas2-pptΔ::URA3* disruptant candidates were selected on SD-Ura plates supplemented with fatty acids. Primers HpKS-3, I-ScURA3F and FAS2-IVRv.2 were then used in a PCR to confirm

the *Scfas2-pptΔ::URA3* disruptant strain. The *Scfas2-pptΔ::URA3* disruptant strain was designated SH8948.

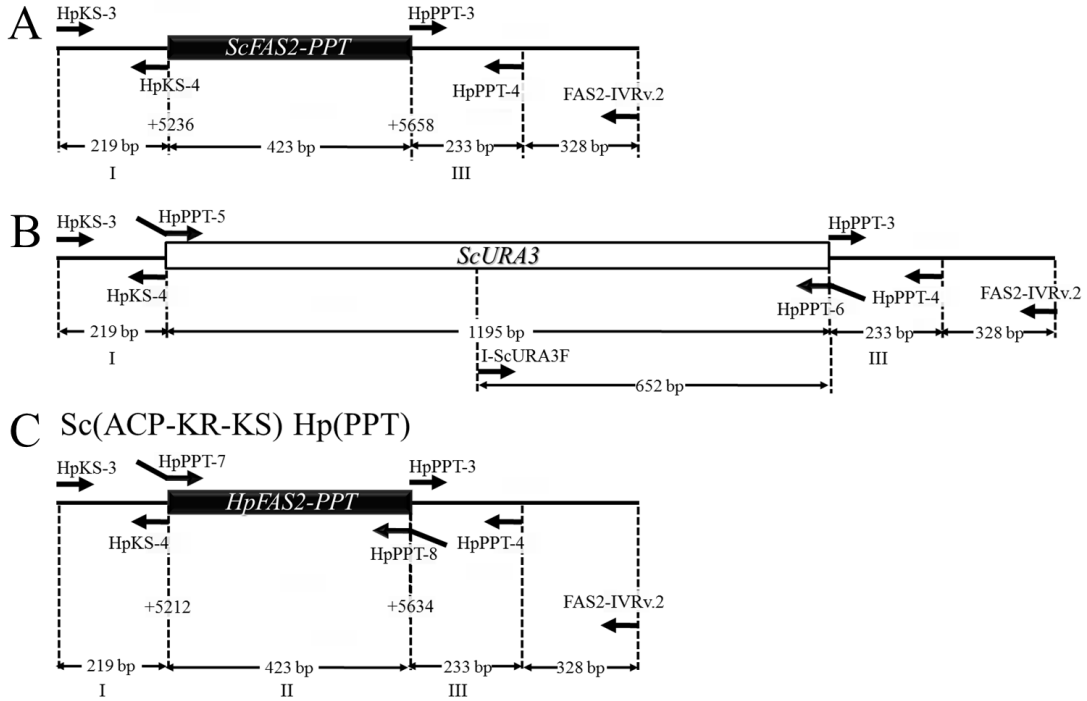

**Fig. 5** Construction of a *ScFAS2-PPT* domain-specific disruption and *HpFAS2-PPT* replacement. A 1.6-kb disruption cassette was prepared by fusion of a 219-bp upstream segment of *ScFAS2-PPT*, *ScURA3* gene and a 233-bp downstream fragment of *ScFAS2-PPT* to create *Scfas2-pptΔ::ScURA3* (B). A 0.9-kb replacement cassette named Sc(ACP-KR-KS) Hp(PPT) were prepared by fusion of the 219-bp upstream segment of *ScFAS2-PPT*, *HpFAS2-PPT* and the 233-bp downstream fragment of *ScFAS2-PPT* (C).

To construct an *S. cerevisiae* strain with the chimeric *FAS2* harboring *HpFAS2-PPT*, we designed a construct to replace the *Scfas2-pptΔ::URA3* locus with the *HpFAS2-PPT* cassette abbreviated Sc(ACP-KR-KS) Hp(PPT) (Fig. 5C) via fusion PCR. In the first-round PCR, genomic DNA from *S. cerevisiae* SH4848 was employed as template to amplify approximately 0.2-kb upstream (I) (219 bp) and downstream (III) (233 bp) fragments of *ScFAS2-PPT* using a pair of forward and reverse primers: HpKS-3 and HpKS-4, and HpPPT-3 and HpPPT-4, respectively (Table 3). Genomic DNA from *H. polymorpha* H50-5C was used as template to generate *HpFAS2-PPT* (II) using

a pair of forward and reverse primers, HpPPT-7 and HpPPT-8. The second round PCR was performed to assemble fragments I, II and III from the first-round PCR to complete construction of the Sc(ACP-KR-KS) Hp(PPT) fragment using primers HpKS-3 and HpPPT-4. The Sc(ACP-KR-KS) Hp(PPT) fragment was subsequently cloned into the *Sma*I site of pUC19 to generate pUC19-HpPPTCas. The plasmid pUC19-HpPPTCas was used as template to amplify the Sc(ACP-KR-KS) Hp(PPT) fragment for further replacement of the *ScFAS2-PPT* locus in the *S. cerevisiae* SH8948 in which *ScFAS2-PPT* had been previously replaced by *ScURA3*. *Scfas2-pptΔ::HpFAS2-PPT* replacement candidates were selected on fatty acid-supplemented 5-FOA plates. Primers I-ScURA3F, HpPPT-7 and FAS2-IVRv.2 were used to confirm the *Scfas2-pptΔ::HpPPT* construct. The *Scfas2-pptΔ::HpFAS2-PPT* replacement strain was named SH8953.

#### **2.2.6 Construction of chimeric *HpFAS2-KS PPT***

Chimeric Fas2 harboring HpFas2 residues 1-976 fused to ScFas2 residues 986-1,887 named Hp(ACP-KR) Sc(KS-PPT) and ScFas2 residues 1-985 fused to HpFas2 residues 977-1,878 designated Sc(ACP-KR) Hp(KS-PPT) were designed. The Hp(ACP-KR) Sc(KS-PPT) was constructed by fusion PCR using two fragments containing Hp(ACP-KR) and Sc(KS-PPT). The Hp(ACP-KR) was amplified using a pair of forward and reverse primers, HpACP-HpKR1v.2 and HpACP-HpKR2v.2, and *S. cerevisiae* KYC1291 genomic DNA as template. The Sc(KS-PPT) was constructed using primers HpACP-HpKR3v.2 and HpACP-HpKR4v.2, and *S. cerevisiae* SH4848 genomic DNA as template. Similarly, the Sc(ACP-KR) Hp(KS-PPT) was obtained by fusion PCR using two fragments containing Sc(ACP-KR) and Hp(KS-PPT). The

Sc(ACP-KR) was amplified using primers HpACP-HpKR1v.2 and HpKS-HpPPT6v.2, and *S. cerevisiae* SH4848 genomic DNA as template. The Hp(KS-PPT) was constructed using primers HpKS-HpPPT7v.2 and HpACP-HpKR4v.2, and KYC1291 genomic DNA as template.

Both Hp(ACP-KR) Sc(KS-PPT) and Sc(ACP-KR) Hp(KS-PPT) chimeric *FAS2* genes were ligated into plasmid pRS314 ([http://yeast.lab.nig.ac.jp/nig/index\\_en.html](http://yeast.lab.nig.ac.jp/nig/index_en.html)). Because primers HpACP-HpKR1v.2 and HpACP-HpKR4v.2 have 20-bp flanking regions of pRS314 sequence incorporating the *SacI* and *KpnI* sites, the chimeric genes were inserted into pRS314 vector via these sites to generate pRS314-AR and pRS314-SP, respectively. The plasmids were then introduced into *Scfas2Δ::CgHIS3* SH8940. We initially screened clones harboring pRS314-SP on fatty acid-supplemented SD-Trp plates. Putative candidates were checked again on YPAD without fatty acid supplementation in order to ascertain the functionality of both chimeric proteins.

Because the Sc(ACP-KR) Hp(KS-PPT) chimeric *Fas2* was found to be functional, we created a *S. cerevisiae* chimeric *FAS2* strain in which the *ScFAS2-KS PPT* was replaced with *H. polymorpha* sequences and subsequently examined its fatty acid profile. pRS314-SP was used as the source of the Sc(ACP-KR) Hp(KS-PPT) fragment for further replacement of the *Scfas2Δ::CgHIS3* locus of *S. cerevisiae* SH8940 to create a *S. cerevisiae* chimeric *FAS2* strain harboring *HpFAS2-KS PPT* (Fig. 6). We screened positive clones on YPAD without fatty acid supplementation and used primers HpKS-3, HpKS-HpPPT7v.2 and HpPPT-4 to confirm the construct. The *S. cerevisiae* chimeric *FAS2* strain harboring *HpFAS2-KS PPT* was named SH8958.

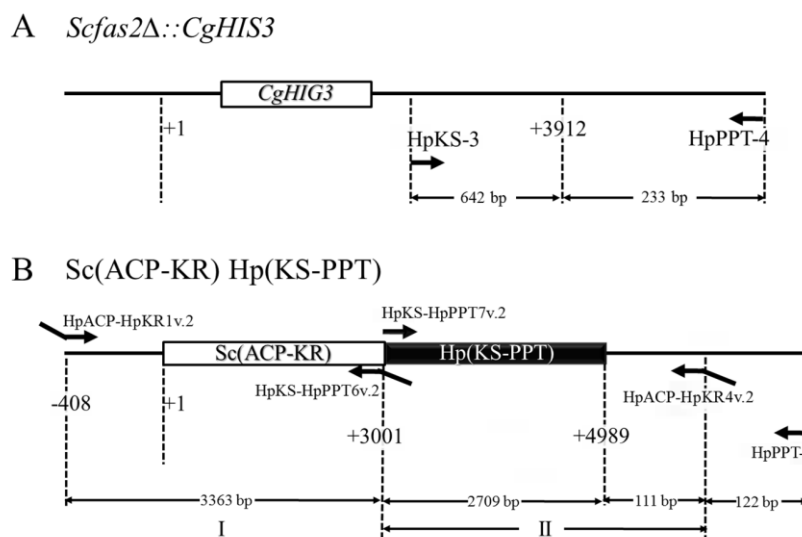

**Fig. 6** Construction of a chimeric *FAS2* cassette containing *HpFAS2-KS PPT* [*Sc(ACP-KR) Hp(KS-PPT)*] obtained by fusion PCR. Fragment I carrying approximately 0.4-kb upstream of *FAS2* and the *ScFAS2-ACP KR* region and fragment II harboring the *HpFAS2-KS PPT* region and 0.1-kb downstream of *FAS2* were amplified in a first PCR. Fragments I and II were fused in a second round of PCR generating *Sc(ACP-KR) Hp(KS-PPT)* cassette (B).

## 2.2.7 Fatty acid analysis

Cultured yeast cells were harvested in stationary phase in 300 ml YPAD broth. Total fatty acids were extracted from approximately 0.2 to 0.25 g wet cells by direct saponification with methanolic potassium hydroxide (2ml of 10% KOH-methanol per 1 g of wet cell) and followed by methyl esterification into fatty acid methyl esters (FAMES) with boron trifluoride methanol complex (Wako). The FAMES were eventually dissolved in 250  $\mu$ l hexane for GC-MS analysis. The GC-MS analysis was done using a Trace DSQ system (Thermo electron Co., Waltham, MA, USA) equipped with OMEGAWAX 250 (30 m  $\times$  0.25 mm I.D.,  $df = 0.25\mu$ m, Sigma-Aldrich). The operational conditions were as follows: injector temperature 250  $^{\circ}$ C; injection volume 1  $\mu$ l; split ratio = 1:10; flow rate 1 ml  $\text{min}^{-1}$ ; carrier gas helium; initial column temperature 50  $^{\circ}$ C held for 2 minutes; column temperature was programmed from 50  $^{\circ}$ C to 230  $^{\circ}$ C at a rate of 4  $^{\circ}$ C  $\text{min}^{-1}$ ; transfer line and ion source temperature 250  $^{\circ}$ C; and mass-to-charge (m/z) range 50-650. Each fatty acid methyl ester was discriminated by retention times

and fatty acid composition was expressed as mol percentage of total fatty acids calculated using 1 mg added n-heptadecanoic acid (C17:0; TOKYO KASEI KOGYO) as an internal standard. The degree of unsaturation was expressed as unsaturation index calculated as follows: unsaturation index = [% monoene + 2 (% diene) + 3 (% triene)]/100.

### 2.2.8 Structure modeling

The crystal structures of *S. cerevisiae* Fas in an open conformation (PDB code 2PFF; Lomakin et al. 2007) and a closed conformation (PDB code 3HMJ; Johansson et al. 2009) were used as starting models. The structures of the open and the closed conformations of *H. polymorpha* Fas were modeled using SWISS-MODEL (<http://swissmodel.expasy.org/>). The Fig. 19 was prepared using PyMOL ver. 1.6 (<http://www.pymol.org/>).

## 2.3 Results

### 2.3.1 Both *HpFAS1* and *HpFAS2* functionally replace *ScFAS1* and *ScFAS2* in *S. cerevisiae*

To determine whether *HpFAS1* and *HpFAS2* are functional in *S. cerevisiae*, each gene was introduced into the corresponding *fas*-disruption mutants of *S. cerevisiae*. Transformants were then screened on YPAD without fatty acid supplementation. One and three transformants were obtained. Because *ScFAS1* and *ScFAS2* had been disrupted by *CgLEU2* and *CgHIS3*, respectively, the successful replacement of *ScFAS1* and *ScFAS2* by *HpFAS1* and *HpFAS2* is supposed to turn the strains from Leu<sup>+</sup> and His<sup>+</sup> back into Leu<sup>-</sup> and His<sup>-</sup> auxotrophy. As we expected, all candidates in both

replacements exhibited Leu<sup>-</sup> and His<sup>-</sup> phenotypes. The replacement alleles were all confirmed to have integrated at the target loci (Fig. 4).

*HpFAS1* replacement strains in *S. cerevisiae* *MATa* and *MATα* backgrounds were designated KYC1289 and KYC1290, respectively. The analogous *HpFAS2* replacement strains of *S. cerevisiae* were named KYC1291 and KYC1292, respectively. Growth phenotypes of *S. cerevisiae* replacement strains harboring either *HpFAS1* or *HpFAS2* are shown in Fig. 7. Since the *HpFAS1* and *HpFAS2* replacement strains were able to grow on fatty acid non-supplemented YPAD, we suggest that both *HpFAS1* and *HpFAS2* replacement strains could synthesize fatty acids. However, it was noted that

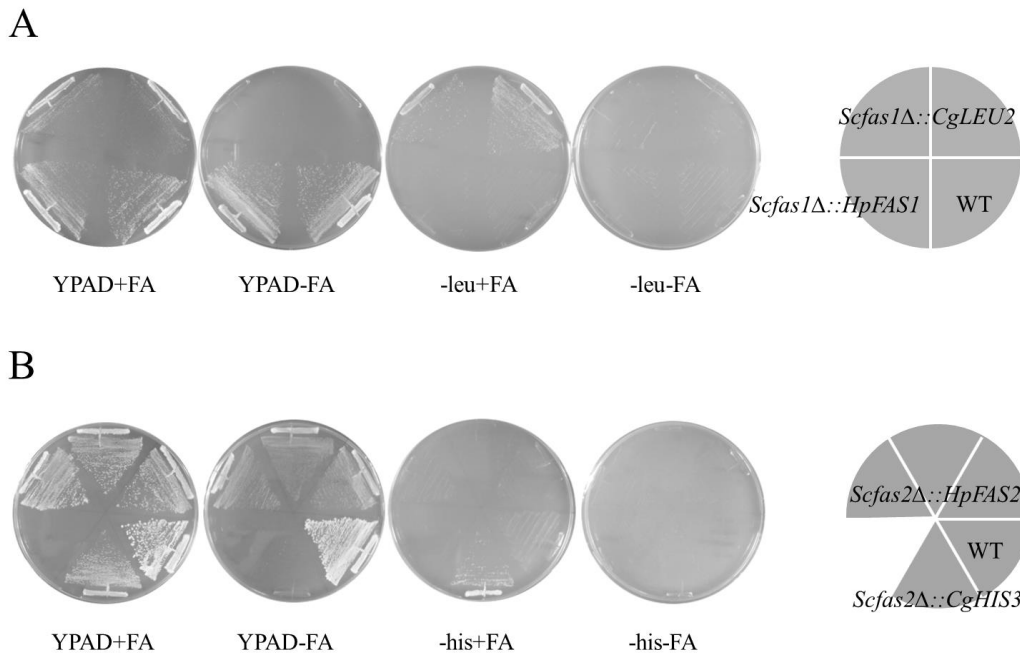

**Fig. 7** Complementation of *ScFAS1* and *ScFAS2* disruption mutations by expression of *HpFAS1* (A) and *HpFAS2* (B) in *S. cerevisiae*. *S. cerevisiae* cells were streaked on YPAD supplemented with fatty acids [myristic acid (C14:0) and palmitic acid (C16:0)] (YPAD+FA), fatty acid non-supplemented YPAD (YPAD-FA), fatty acid-supplemented synthetic dextrose media (SD) (-leu+FA) or (-his+FA) and fatty acid non-supplemented SD (-leu-FA) or (-his-FA) for *HpFAS1* and *HpFAS2* replacement strains, respectively. Photographs were taken after 2 days for the *HpFAS1* replacement strain and 3 days for the *HpFAS2* replacement strains.

growth of the *S. cerevisiae* replacement strain harboring *HpFAS2* was slower than both *HpFAS1* replacement strain and the wild-type strain. These results suggest that hybrid Fas complexes, *HpFas1/ScFas2* and *ScFas1/HpFas2* function in fatty acid synthesis in *S. cerevisiae*, although the function of the *ScFas1/HpFas2* hybrid was apparently sub-optimal. Double *HpFAS1HpFAS2* replacement *S. cerevisiae* strains, which were subsequently constructed by crossing single *HpFAS1* with *HpFAS2* replacement strains and were designated KYC1293 and KYC1294. The double *HpFAS1 HpFAS2* replacement strains were also able to grow on fatty acid non-supplemented YPAD (data not shown). We therefore suggest that the double *HpFAS1 HpFAS2* replacement strains

**Table 4** Relative fatty acid composition of wild-type and constructed yeast strains.

Strain	Fatty acid composition in total fatty acids (mol %) <sup>a, b</sup>				Unsaturation Index	C16/C18 <sup>b</sup>
	Short FA Species	C14	C16	C18		
<i>S. cerevisiae</i> W303-1A	2.8±0.6	2.7±0.2	64±0.5	30±0.9	0.7±0.0	2.2±0.1
Sc(ACP-KR-KS) Hp(PPT)	2.1±0.4	1.5±0.1	66±0.6	30±0.7	0.8±0.0	2.2±0.1
<i>HpFAS1 ScFAS2</i>	ND	0.6±0.1	50±3.1	49±3.2	0.7±0.0	1.0±0.1
<i>HpFAS1 HpFAS2</i>	ND	ND	44±4.8	56±4.8	0.8±0.0	0.8±0.1
Sc(ACP-KR) Hp(KS-PPT)	ND	ND	38±3.1	63±3.1	0.9±0.0	0.6±0.1
<i>ScFAS1 HpFAS2</i>	ND	ND	31±9.5	69±9.3	0.9±0.0	0.5±0.2
<i>H. polymorpha</i> H50-5C	ND	0.8±0.3	23±0.4	77±0.2	1.0±0.0	0.3±0.0

<sup>a</sup>Cultures were grown in YPAD at 30°C (*S. cerevisiae*) or 37°C (*H. polymorpha*) and cells were harvested in stationary phase for fatty acid analysis.

<sup>b</sup>Values represent the mean of at least three independent experiments.



could synthesize fatty acids as well. These results clearly indicate that the *HpFas1/HpFas2* complex can substitute for the original *ScFas1/ScFas2* complex in *S. cerevisiae*.

### 2.3.2 Replacement of Fas2 ( $\alpha$ subunit) causes drastic change in C16/C18 ratio

A decrease in C16 and an increase in C18 fatty acids were observed in *HpFAS1 ScFAS2* (KYC1289), *ScFAS1 HpFAS2* (KYC1291) single and *HpFAS1 HpFAS2* (KYC1293) double replacement *S. cerevisiae* strains relative to wild-type *S. cerevisiae* (SH4848). The C16/C18 ratios of fatty acids in the cells decreased from  $2.2\pm 0.1$  to  $1.0\pm 0.1$ ,  $0.5\pm 0.2$  and  $0.8\pm 0.1$  due to the *HpFAS1*, *HpFAS2* single and *HpFAS1 HpFAS2* double gene replacement, respectively (Table 4). The *HpFAS2* replacement strain was

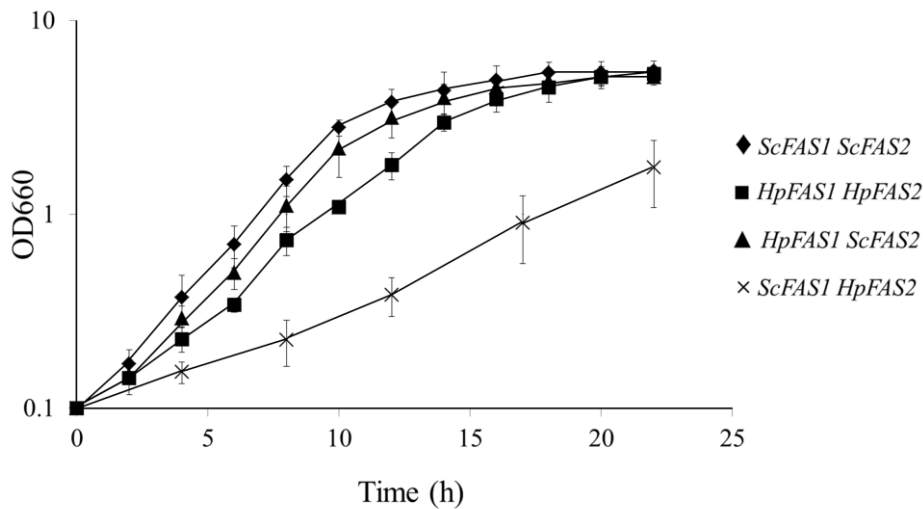

**Fig. 8** Growth characteristics of *HpFAS1* (*HpFAS1 ScFAS2*; KYC1289, ▲), *HpFAS2* (*ScFAS1 HpFAS2*; KYC1291, X ) single and *HpFAS1HpFAS2* (*HpFAS1 HpFAS2*; KYC1293, ■) double replacement strains compared to *S. cerevisiae* (*ScFAS1 ScFAS2*; SH4848, ◆) at 30 °C. Yeast strains were grown in fatty acid non-supplemented liquid YPAD starting with an initial OD660 = 0.1. Growth rates were determined by monitoring OD660 every 2 hours for wild-type *S. cerevisiae*, *HpFAS1 ScFAS2* and *HpFAS1 HpFAS2* strains, and every 4 hours for the *ScFAS1 HpFAS2* strain.

found to exhibit a severe growth defect at 30 °C in YPAD without fatty acid supplementation (Fig. 8). Likewise, when these strains were ranked in order of growth rate (Fig. 8), a direct correlation to C16/C18 ratio and an inverse correlation to unsaturation indices (Table 4) were observed. These observations suggest that the *ScFAS2/HpFAS2* gene is a major determinant of acyl chain length as it accounted for the greatest change in C16/C18 ratio comparable to that in *H. polymorpha* wild-type strain. Because a greater amount of longer chain-length of fatty acid decreases membrane fluidity, the drastic decrease in C16/C18 ratio found in the *HpFAS2* replacement strain may cause the slow growth observed in this strain. We suggest that Fas2 makes more of a contribution than Fas1 to the difference in C16/C18 ratio, raising the question of precisely what region within the Fas2 subunit is responsible.

### **2.3.3 KS domain in Fas2 plays a major role in fatty acyl chain length determination**

Fas2 carries ACP, KR, KS and PPT domains. To investigate which specific domain in Fas2 is responsible for determination of fatty acyl chain length, we constructed chimeric Fas2 proteins in the *S. cerevisiae* background. Positive clones able to grow on fatty acid-supplemented SD-Trp plates were obtained in Hp(ACP-KR) Sc(KS-PPT) and Sc(ACP-KR) Hp(KS-PPT) cases. However, upon further investigation, only *S. cerevisiae* carrying Sc(ACP-KR) Hp(KS-PPT) was able to grow on medium without fatty acid supplementation while the strain harboring Hp(ACP-KR) Sc(KS-PPT) was not. This indicates that only chimeric Fas carrying ScFas2 residues 1-985 fused to HpFas2 residues 977-1,878 was functional whereas chimeric Fas carrying HpFas2 residues 1-976 fused to ScFas2 residues 986-1,887 [Hp(ACP-KR) Sc(KS-PPT)]

was catalytically inactive. We were therefore able to create *S. cerevisiae* strains harboring chimeric *FAS2* in which *ScFAS2-PPT* and *ScFAS2-KS PPT* were replaced with corresponding *H. polymorpha* sequences. The fatty acid profiles of *S. cerevisiae* harboring chimeric *FAS2* with replacements for *HpFAS2-PPT* and *HpFAS2-KS PPT* were investigated in order to determine the specific region in *FAS2* that served as the major determinant of fatty acyl chain length. *HpFAS2-PPT* was found not to contribute to changes in fatty acid profile, yielding the same C16/C18 ratio as observed in the wild-type *S. cerevisiae* strain [Sc(ACP-KR-KS) Hp(PPT); Table 4]. This ruled out the PPT domain as a contributor to fatty acyl chain length determination. Intriguingly, the presence of *HpFAS2-KS PPT* contributes to the drastic change in C16/C18 ratio [Sc(ACP-KR) Hp(KS-PPT); Table 4], closely resembling to the result observed by the

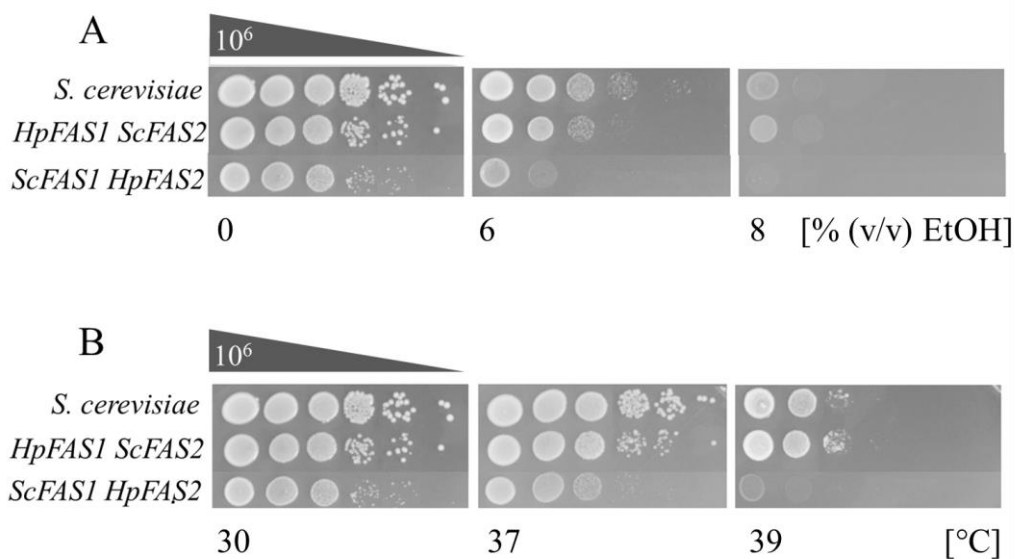

**Fig. 9** Growth of *HpFAS1 ScFAS2* (KYC1289) and *ScFAS1 HpFAS2* (KYC1291) replacement strains upon exposure to ethanol (A) and different temperatures (B). *S. cerevisiae* cells were spotted on fatty acid non-supplemented YPAD media containing 0, 6 and 8 % (v/v) ethanol and on fatty acid non-supplemented YPAD at 30, 37 and 39 °C. Photographs were taken after 2 days for the *HpFAS1 ScFAS2* and the original *S. cerevisiae* strains and after 3 days for the *ScFAS1 HpFAS2* strain.

replacement with full-length *HpFAS2*. This implies that the KS domain, but not other domains in *Fas2* play a major role in fatty acyl chain length determination.

### **2.3.4 Both *HpFAS* replacement strains are sensitive to high ethanol and high growth temperature**

*HpFAS* replacement *S. cerevisiae* strains were examined for the ability to grow in the presence of 8 % (v/v) ethanol, and separately, at high temperature (39 °C). Even though the *HpFAS1* and *HpFAS2* replacement strains had higher C18:1 levels, similar to strains tolerant to high ethanol concentrations (You et al. 2003), no improvement in growth phenotype was observed relative to the wild-type *S. cerevisiae* strain (Fig. 9). These observations suggest that the hybrid *Fas*-mediated change in fatty acid composition alone is not sufficient to confer tolerance to either high temperature or 8 % (v/v) ethanol.

## **2.4 Discussion**

I investigated *Fas* structure-function relationship by creating chimeric genes combining *FAS* sequences from *S. cerevisiae*, which mainly produces C16 fatty acids and *H. polymorpha*, which mostly synthesizes C18 fatty acids. Because the replacement of *ScFAS2* by the *HpFAS2* gene resulted in the greatest decrease in C16/C18 ratio, relative to the replacement of *ScFAS1* by the *HpFAS1* gene, or the double replacement of *ScFAS1 ScFAS2* by *HpFAS1 HpFAS2* genes, we concluded that *Fas2*, or  $\alpha$  carrying the ACP, KR, KS and PPT domains, plays a major role changing the C16/C18 ratio. By construction of chimeric *Fas2* strains, the truncated C-terminus of *Fas2* (residues 977-1,878) harboring the KS domain, but not the last 141 residues of

Fas2 harboring the PPT domain was found to be responsible for the change in C16/C18 ratio.

I speculate that *S. cerevisiae* has higher levels of C16 fatty acids and *H. polymorpha* has higher levels C18 fatty acids because of differences in their respective Fas proteins. What makes the reaction terminate progressive rounds of elongation of the FAS cycle and allow the final fatty acid product to be liberated or extended? Here, I propose that the preference for termination of the synthesis may be due to one of the following mechanisms: 1) the MPT does not charge the elongating unit with a malonyl moiety on the ACP, 2) the KS does not catalyze decarboxylative condensation of the ACP-attached malonyl moiety with the growing chain, or 3) the ACP has lower affinity to bind each catalytic domain when the chains reach Fas-specific preferred chain lengths. To verify which domain is responsible for termination of fatty acid synthesis, systematic analysis of each domain-specific chimeric Fas might be considered.

Maier et al. (2010) has noted that the MPT has a deep hydrophobic crevice that appears to be optimally suited for binding the hydrophobic tail of C16 which would prevent the premature release of products. However, the MPT cleft does not measure the length of the acyl chain in a strict sense because the MPT is able to transfer acyl chains of various lengths from C6 to C18 readily with similar efficiencies if CoAs are available. In addition, if the supply of malonyl-CoA is limited, the formation of fatty acid products with shorter chain lengths is promoted. This suggests that the determination of fatty acyl chain length is controlled by an intricate equilibrium of malonyl substrate or CoA required for back-transfer into fatty acyl-CoA products. In agreement with our expectations in case of *Streptomyces* and filamentous fungi Fas, it was reported that the chain length of products from type II polyketide synthases (PKSs)

is determined by minimal PKS (Bisang et al. 1999). The minimal PKS consists of the combination of  $\beta$ -ketoacyl synthase-chain length factor (KS-CLF) complex with ACP and malonyl-CoA:ACP transacylase, which has the same function as MPT in Fas. In contradiction to this possibility, Oura and Kajiwara (2006) reported in a study of chimeric *S. kluyveri* FAS2 in a *S. cerevisiae* *fas2* mutant that the N-terminal Fas2 region which includes the ACP and almost all the KR domain plays an important role in determination of fatty acyl chain length. Unfortunately, our chimeric Fas2 containing a replacement for the truncated N-terminal HpFas2 (residues 1-976) was catalytically inactive. Therefore, we could not observe fatty acid profile of the strains containing a replacement for the truncated N-terminal HpFas2 residues 1-976. However, if we could have changed amino acid position of the replacement resulting in an active chimeric Fas2 harboring the N-terminus of HpFas2, we might have been able to determine the importance of the N-terminal region of Fas2 in the determination of fatty acids. Construction of additional chimeric Fas proteins combined with site-directed mutagenesis is likely to better define the critical domain or region that determines termination of fatty acid biosynthesis. Furthermore, *in vitro* investigation of end products from chimeric Fas enzymes may provide key mechanistic information relative to how chain length is determined.

The double *HpFAS1 HpFAS2* replacement strain did not yield the lowest C16/C18 ratio as observed in the wild-type *H. polymorpha* strain. This could be explained by the possibility that HpFas1 and HpFas2 do not function optimally in *S. cerevisiae* cells due to undefined background effects related to intracellular milieu. *S. cerevisiae* containing HpFas2 was found to grow slowly relative to other chimeric strains and the original Fas strains. This contrasts with a report that FAS2 gene from *S.*

*kluyveri* was able to complement a *S. cerevisiae fas2* mutation, resulting in a strain that grew at the same rate as the wild-type *S. cerevisiae* strain (Oura and Kajiwara 2006). This difference might be due to the greater degree of relatedness between the Fas sequences found in *S. cerevisiae* and *S. kluyveri* compared to *S. cerevisiae* and *H. polymorpha*.

Because the cell membrane is the primary barrier that shields cells from environmental stress, the dynamic structure and organization of membrane lipids allows adaptation to sudden environmental changes. It has been reported that a reduction in palmitic acid (C16:0) levels may account for the process of ethanol adaptation in *S. cerevisiae* exposed to high concentrations of ethanol (Dinh et al. 2008). Increased incorporation of oleic acid (C18:1) into yeast membrane lipids has also been reported to contribute to greater ethanol tolerance (You et al. 2003), presumably due to a plausible compensatory decline in membrane fluidity. Moreover, accumulation of C18:1 but not C16:1 in *S. cerevisiae* was found to increase tolerance to alcohols (Yazawa et al. 2011). I presumed that the artificial changes in fatty acid composition resulting from switching Fas subunits which account for a drastic increase in C18:1 with a compensatory decrease in C16:0 and C16:1 would improve yeast tolerance for high ethanol concentration and high growth temperature. However, yeast strains harboring hybrid Fas did not exhibit greater stress tolerance, suggesting that variation in membrane fluidity due to change in fatty acid composition might not fully explain the tolerance to high temperature and ethanol, and thus other factors or mechanisms in lipid metabolism are potentially also involved.

The present study provides structure-function data for yeast Fas activity relative to fatty acid composition. Specifically, we have shown that the condensation step

performed by the KS domain in Fas2 plays a major role in the determination of fatty acyl chain length while Fas1 does a minor one. Taken together, our observations suggest that the KS domain may be a productive target for engineering synthesis of fatty acid products of specific chain length.

### 3.5 Summary

To determine features of yeast Fas that control fatty acyl chain length, hybrid genes were constructed by combining *FAS* sequences from *S. cerevisiae* (*ScFAS*) and *H. polymorpha* (*HpFAS*), which mostly produces C16 and C18 fatty acids, respectively. The C16/C18 ratios decreased from  $2.2 \pm 0.1$  in wild-type *S. cerevisiae* to  $1.0 \pm 0.1$ ,  $0.5 \pm 0.2$  and  $0.8 \pm 0.1$  by replacement of *ScFAS1*, *ScFAS2*, and *ScFAS1 ScFAS2* with *HpFAS1*, *HpFAS2*, and *HpFAS1 HpFAS2*, respectively, suggesting that the  $\alpha$ , but not  $\beta$  subunits play a major role. Replacement of phosphopantetheinyl transferase (PPT) domain with the equivalent region from *HpFAS2* did not affect C16/C18 ratio. Chimeric Fas2 containing half N-terminal ScFas2 and half C-terminal HpFas2 carrying *H. polymorpha* ketoacyl synthase (KS) and PPT gave a remarkable decrease in C16/C18 ratio ( $0.6 \pm 0.1$ ), indicating that KS plays a major role in determining chain length.



## Chapter 3

### Cloning and functional analysis of *HpFAD2* and *HpFAD3* genes encoding $\Delta$ 12- and $\Delta$ 15-fatty acid desaturases in *Hansenula polymorpha*

#### 3.1 Introduction

Linoleic acid (LA, C18:2) and  $\alpha$ -linolenic acid (ALA,  $\alpha$ C18:3) are considered to be the bottleneck in the production of downstream essential PUFAs in *S. cerevisiae*, my focus has shifted to the development of *H. polymorpha* cells as a much more efficient organism for the production of C18:2 and  $\alpha$ C18:3 precursors. To enable us to manipulate *H. polymorpha* cells to synthesize specific PUFAs in satisfactory yield, fundamental knowledge of how *H. polymorpha* controls the fatty acid desaturation machinery for the production of C18:2 and  $\alpha$ C18:3 is needed. I therefore plan to identify and characterize functions of two genes involved in the production of C18:2 and  $\alpha$ C18:3 in *H. polymorpha* for benefit in comparative biology although so far many genes encoding  $\Delta$ 12- and  $\Delta$ 15-fatty acid desaturases in various organisms have been reported (Arondel et al. 1992; Yadav et al. 1993; Okuley et al. 1994; Huang et al. 1999; Passorn et al. 1999; Sakuradani et al. 1999; Calvo et al. 2001; Oura and Kajiwara 2004; Watanabe et al. 2004; Sakuradani et al. 2005; Wei et al. 2006; Zhang et al. 2008; Li et al. 2011).

In Chapter 3, in an effort to elucidate the functions of two fatty acid desaturase genes, named *HpFAD2* and *HpFAD3* that encode *H. polymorpha*  $\Delta$ 12- and  $\Delta$ 15-fatty acid desaturases involved in PUFA synthesis, I have cloned and characterized these

genes. I created deletion mutants of *HpFAD2* and *HpFAD3* in *H. polymorpha* and also examined heterologous expression of *HpFAD2* and *HpFAD3* in *S. cerevisiae* cells. As seen in the *S. cerevisiae OLE1* gene, upstream sequences of *HpFAD2* and *HpFAD3* contain a Fatty Acid Regulated (FAR) region and a Low Oxygen Response Element (LORE), which are potentially responsible for unsaturated fatty acid and hypoxia-mediated transcriptional control. I found that the transcriptions of both genes were induced under hypoxic conditions. However, the transcriptional expression of *HpFAD2* was not controlled by fatty acids, whereas that of *HpFAD3* transcription was repressed by C18:1, C18:2 and  $\alpha$ C18:3. I propose that *HpFAD2* may be controlled by post-transcriptional mechanisms, but *HpFAD3* is regulated mainly at a transcriptional level.

## **3.2 Materials and methods**

### **3.2.1 Yeast strains and culture conditions**

The *H. polymorpha* and *S. cerevisiae* strains used in this Chapter are shown in Table 5. Cells were cultivated at 30°C for *S. cerevisiae* and 37°C for *H. polymorpha*, unless otherwise noted, in rich media (YPDA) consisting of 1% Bacto-yeast extract (BD Bioscience, Sparks, MD, USA); 1% Bacto-peptone (BD); 2% glucose and 0.02% adenine. Synthetic dextrose (SD) media (2% glucose, 0.67% nitrogen base without amino acids) and 5-FOA (2% glucose, 0.1% 5-fluoro-orotic acid (5-FOA), 0.005% uracil, 0.67% nitrogen base without amino acids) were used for isolation of disruptant strains. After media were autoclaved, 0.1 mg/ml of Zeocin (Invitrogen) was added. For media supplemented with exogenous fatty acids, each of fatty acid species (Wako) was added at 0.5 mM, emulsified by 1% w/v of Brij58 (Sigma) was used. For plate culture,

**Table 5** Strains used in this Chapter

Strain	Genotype and remarks	Source
<i>Hansenula polymorpha</i>		
SH4329	<i>leu1-1</i>	Our stock
SH4331	<i>ade11-1</i>	Our stock
H50-5C	<i>leu1-1 ura3-1</i>	Our stock
HR2-D57	<i>leu1-1 Hpfad2Δ::Zeo</i>	This study
HT3-D22	<i>leu1-1 ura3-1 Hpfad3Δ::HpURA3</i>	This study
<i>Saccharomyces cerevisiae</i>		
SH6314(BY4742)	<i>MATa ura3-Δ0 leu2-Δ0 his3-Δ1 lys2-Δ0</i>	Our stock
KYC525(W303-1A)	<i>MATa ura3-1 leu2-3,112 trp1 his3-11,15 ade2-1 can1-100</i>	Our stock
SR2V	<i>MATa ura3-Δ0 leu2-Δ0 his3-Δ1 lys2-Δ0 [YE<sub>p</sub>-GAL1p+URA3]<sup>a</sup></i>	This study
SR2E	<i>MATa ura3-Δ0 leu2-Δ0 his3-Δ1 lys2-Δ0 [YE<sub>p</sub>-GAL1p-HpFAD2+URA3]<sup>b</sup></i>	This study
SR2VE	<i>MATa ura3-1 leu2-3,112 trp1 his3-11,15 ade2-1 can1-100 [YE<sub>p</sub>-GAL1p+URA3]<sup>a</sup></i>	This study
SR2EX	<i>MATa ura3-1 leu2-3,112 trp1 his3-11,15 ade2-1 can1-100 [YE<sub>p</sub>-GAL1p-HpFAD2+URA3]<sup>b</sup></i>	This study
SR3VE	<i>MATa ura3-1 leu2-3,112 trp1 his3-11,15 ade2-1 can1-100 [YE<sub>p</sub>-TDH3p+TRP1]<sup>c</sup></i>	This study
SR3EX	<i>MATa ura3-1 leu2-3,112 trp1 his3-11,15 ade2-1 can1-100 [YE<sub>p</sub>-TDH3p-HpFAD3+TRP1]<sup>d</sup></i>	This study

Remarks: <sup>a</sup>pYES2 expression vector controlled with the *GAL1* promoter.

<sup>b</sup>pYES2 expression vector containing the *HpFAD2* gene controlled with the *GAL1* promoter.

<sup>c</sup>p520 expression vector controlled with the *TDH3* promoter.

<sup>d</sup>p520 expression vector containing the *HpFAD3* gene controlled with the *TDH3* promoter.

2% agar was added. In order to induce expression of the *S. cerevisiae GAL1* promoter, yeast cells were shifted into medium supplemented with 2% raffinose and 0.2% galactose. For experiments assessing transcription levels under hypoxic conditions, mid-log phase preparative cultures were used to inoculate special air-tight flasks with inlet and outlet ports to facilitate the replacement of oxygen with nitrogen gas. Cultures were exposed to a continuous flow of hydrated nitrogen.

### 3.2.2 Genetic and biochemical procedures

The primers used in this Chapter are listed in Table 6. The DNA manipulation of *E. coli* and yeasts followed standard procedures (Sambrook et al. 1989). Restriction

**Table 6** Primers used in this Chapter

Name	Nucleotide sequence (5' to 3')
HpD12-1F	5'-TTTCTTCTGGACCTCGCTC-3'
HpD12-1R	5'-TCTACAAAACCGCAAATAGCATC-3'
HpD12-2F	5'-GACTATTGCCGTTTGTCTCGCC-3'
HpD12-2R	5'-TTTGGAGCCACCCCCACACCG-3'
FAD2-3NR	5'- <u>CATGTCAGTCAGTCAGGATCCTAGGATACCACCACCAGCCTCC</u> -3'
FAD2-4CF	5'- <u>TAATTTGCAAGCTGGAGACCAACA</u> CTTCAACCTGCGTCGCCG-3'
Zeo-1F	5'-CTAGGATCCTGACTGACTGAC-3'
Zeo-1R	5'-TGTTGGTCTCCAGCTTGCAA-3'
SkFAD3-3F	5'-GAATGTGGCCACTCCGCTTTTTTCGG-3'
SkFAD3-4F	5'-GGTTTATCCCATGGCTATGGG-3'
FAD3EX-1F	5'- <u>CGGAATTCATGTCTGCTGTTACTACCGG</u> -3'
FAD3EX-1R	5'- <u>CGGGATCCCTATGCACCGACACCAATA</u> -3'
FAD3-D6F	5'- <u>CTGCTGCCACCATCGATCTTTCGGAGTGCTTGAGG</u> -3'
FAD3-D6R	5'- <u>CCGAACTCTCTATCGATAGGTCCACCTGACTAGAC</u> -3'
ACT-RTF5	5'-CGGATCCGGTATGTGCAAAG-3'
ACT-RTR5	5'-TCCGACAATCGAAGGAAACAC-3'
FAD2-RTF4	5'-CGCTGCCTTATACTGGACTATGG-3'
FAD2-RTR4	5'-CAGCCGTAGTCCGAAAATGC-3'
FAD3-RTF4	5'-GCTTAACATGGCCGTCAACTG-3'
FAD3-RTR4	5'-TGAAGGAACGTCACAAACACAAG-3'

enzymes, DNA polymerase for polymerase chain reaction (PCR) and other DNA-manipulating enzymes (Takara Bio Inc.) were all used in accordance with the manufacturer's instructions. Genetic analysis including yeast transformation, mating, sporulation and tetrad dissection were performed as described (Amberg et al. 2005). Southern analysis was performed using an ECL direct nucleic acid labeling and detection system (GE Healthcare). Genomic DNA of yeast strains (10µg each) was digested by appropriate restriction enzymes, electrophoresed for 3 h at a constant voltage at 50 V on a 0.8 % agarose gel, and then transferred onto a nylon filter (Hybond-N<sup>+</sup>; GE Healthcare) in 20X SSC by a standard method (Sambrook et al. 1989). Hybridization, washing and detection were performed using an ECL system in accordance with the manufacture's recommendations.

### **3.2.3 Cloning of *HpFAD2* and *HpFAD3***

To clone the *HpFAD2* gene, forward and reverse primers, HpD12-1F and HpD12-1R were designed on the basis of a highly conserved nucleotide sequence of the Δ12-fatty acid desaturase gene from *Arabidopsis thaliana AtFAD2* (GenBank ID: AEE75152). A DNA fragment approximately 1.5-kb was obtained by PCR with ExTaq DNA polymerase using genomic DNA of *H. polymorpha* SH4329 as a template. The fragment was then cloned into pCR2.1 by TA cloning (Invitrogen) to create a vector designated pFA201 and the nucleotide sequence was substantially determined.

To clone the *HpFAD3* gene, we created a rough restriction map around the *HpFAD3* locus by single digestion of *H. polymorpha* strain SH4329 genomic DNA with the enzymes *EcoRI*, *XhoI*, *Sall*, *BglIII* and *HindIII*, and also double digestion of all combinations, followed by Southern analysis using *Saccharomyces kluyveri FAD3*

(*SkFAD3*; GenBank ID: BAD11952) as a probe. Considering the rough restriction map, we found that *Bgl*III and *Xho*I were appropriate for cloning of *HpFAD3* gene because the *Bgl*III and *Xho*I fractionated fragment covered the whole length of the putative *HpFAD3* gene. We therefore double-digested *H. polymorpha* strain SH4329 genomic DNA with *Bgl*III and *Xho*I. The *Bgl*III and *Xho*I fractionated fragments were cloned into pBluescript II KS+ (STRATAGENE) to construct a genomic DNA library. Screening of clones harboring *HpFAD3* was done by colony hybridization using a 0.8 kb-amplified fragment from partial *SkFAD3* using SkFAD3-3F and SkFAD3-4R primers as a probe. The plasmid from the positive clone, designated pFA301, was then extracted for further sequencing.

#### **3.2.4 Disruption of *HpFAD2* and *HpFAD3***

We designed a construct to replace *HpFAD2* with a Zeocin marker gene. The *HpFAD2* disruption cassette was prepared by double-fusion PCR. In the first-round PCR, genomic DNA of *H. polymorpha* SH4329 was employed as a template to amplify 0.4 kb-upstream and 0.5 kb-downstream fragments of *HpFAD2* using HpD12-2F/FAD2-3NR and FAD2-4CF/HpD12-2R primers. pREMI-Z (Dijk et al. 2001) was used as a template to generate Zeocin resistance cassette using Zeo-1F and Zeo-1R primers. In the first fusion PCR, the 0.4 kb-upstream fragment of *HpFAD2* was fused with the Zeocin resistance cassette. The PCR product from the first fusion was then assembled with the 0.5 kb-downstream fragment of *HpFAD2* in the second fusion PCR to complete the *HpFAD2* disruption cassette.

To prepare the *Hpfad3* $\Delta$ ::*URA3* disruption cassette, the *HpURA3* gene was amplified by using pBSSK\_URA3Hp.or1, which was previously prepared by insertion

of a 2.3 kb-*HpURA3* fragment into the *SmaI* site of pBluescript SK+, as a template. Because FAD3-D6F and FAD3-D6R primers have flanking *ClaI* sites at both ends, the amplified *HpURA3* gene could be inserted into pFA301, a plasmid harboring the *HpFAD3* gene cut with *ClaI*, thereby providing a plasmid containing the *Hpfad3Δ::URA3* disruption cassette designated pFAD3-dis. Plasmid pFAD3-dis was further digested with *KpnI* to release the *Hpfad3Δ::URA3* disruption cassette for construction of the *Hpfad3Δ* disruptant strain.

### **3.2.5 Heterologous expression of *HpFAD2* and *HpFAD3* in *S. cerevisiae***

Heterologous expression of *HpFAD2* and *HpFAD3* was conducted in *S. cerevisiae* separately to characterize their desaturase functions. To construct *S. cerevisiae* expressing *HpFAD2*, plasmid pFA201 harboring the *HpFAD2* gene was cut with *EcoRI* and subsequently inserted into plasmid pYES2 (Invitrogen) to obtain an expression vector named pFAD2EX. Plasmid pFAD2EX was then introduced into *S. cerevisiae* SH6314 by transformation. *HpFAD2* was expressed under transcriptional control of the *S. cerevisiae GAL1* promoter. For heterologous expression of *HpFAD3* in *S. cerevisiae*, the *HpFAD3* gene was amplified by PCR using FAD3EX-1F and FAD3EX-1R primers and pFA301 carrying the *HpFAD3* gene (see 3.2.3) as a template, and inserted into the *EcoRI/BamHI* sites of plasmid p520 (Anamnart et al. 1997) to yield a *HpFAD3* expression vector named pFAD3EX. Plasmid pFAD3EX was then introduced into *S. cerevisiae* KYC525 by transformation. *HpFAD3* was expressed under transcriptional control of the *S. cerevisiae TDH3* promoter.

### 3.2.6 RNA isolation, cDNA preparation, and quantitative real-time PCR

Yeast cells were grown to mid-log phase ( $OD_{600} = 1.0$ ) at 37 °C in 50 ml of YPDA containing 0 mM (w/o FA) or 1 mM oleic acid (C18:1), 1 mM linoleic acid (C18:2), or 1 mM  $\alpha$ -linolenic acid ( $\alpha$ C18:3). Total RNAs were isolated from cells by using Multibeads Shocker (Yasui Kikai) with TRIzol reagent (Invitrogen) according to the manufacturer's instructions. For the preparation of cDNA, extracted RNAs were treated with DNase I (Takara Bio Inc.) and reverse-transcribed by using a High-Capacity cDNA Archive Kit (Applied Biosystems) according to the manufacturer's instructions. Quantitative real-time PCR was performed in triplicate using SYBR green PCR Master Mix (Applied Biosystems) and an Applied Biosystems 7300 real-time PCR system (Applied Biosystems) according to the manufacturer's instructions. Relative mRNA levels were normalized to *ACT1* mRNA levels. The following primers were used for quantitative real-time PCR: ACT-RTF5/ACT-RTR5 for *ACT1* mRNA, FAD2-RTF4/FAD2-RTR4 for *FAD2* mRNA and FAD3-RTF4/FAD3-RTR4 for *FAD3* mRNA.

### 3.2.7 Fatty acid profile analysis

Cultured yeast cells were harvested at stationary phase in 300 ml of YPDA broth and then washed with 1% Brij58 water (Sigma). Total fatty acids were extracted from approximately 0.20 to 0.25 g of wet cells by direct saponification with methanolic potassium hydroxide (2ml of 10% KOH-methanol per 1 g of wet cells), and methyl-esterified into the fatty acid methyl ester form (FAME) with boron trifluoride methanol complex (Wako). The fatty acid methyl esters were eventually dissolved in 250  $\mu$ l of hexane for further GC-MS analysis.



GC-MS analysis was done using a Trace DSQ system (Thermo electron Co., Waltham, MA, USA) equipped with OMEGAWAX 250 (30 m × 0.25 mm I.D., df = 0.25µm, Sigma-Aldrich). The operational conditions were as follows: injector temperature, 250°C; injection volume, 1 µl; split ratio, 1:10; flow rate, 1 ml min<sup>-1</sup>; carrier gas, helium; initial column temperature, 50°C held for 2 min; column temperature gradient, 50°C to 230°C at a rate of 4°C min<sup>-1</sup>; transfer line and ion source temperature, 250°C; and mass-to-charge (m/z) range, 50-650. Each fatty acid methyl ester was discriminated owing to its retention time, and fatty acid compositions were expressed as mol percentage of total fatty acids calculated using 1 mg of added n-heptadecanoic acid (C17:0; TOKYO KASEI KOGYO) added as an internal standard. The degree of unsaturation was expressed as an unsaturation index, calculated as follows: unsaturation index = [% monoene + 2 (% diene) + 3 (% triene)]/100.

### **3.3 Results**

#### **3.3.1 Isolation of the *HpFAD2* and *HpFAD3* genes**

The deduced gene encoding Δ12-fatty acid desaturase in *H. polymorpha*, named *HpFAD2*, was cloned as nucleotide sequence showing high conservation to the Δ12-fatty acid desaturase gene from *A. thaliana*, *AtFAD2*. Sequencing data suggested that the cloned fragment consists of a 1,215-bp open reading frame (ORF) with 241-bp and 62-bp upstream and downstream regions, respectively. The sequencing data obtained were found to be identical to those of the *Ogataea angusta* Δ12-fatty acid desaturase (GenBank ID: ADL18371). Our sequence data was submitted to the DDBJ and assigned the accession number AB778510.

I also isolated a putative *H. polymorpha*  $\Delta$ 15-fatty acid desaturase gene, designated *HpFAD3*, by colony hybridization using a partially amplified fragment of the highly conserved region in *S. kluyveri* *FAD3* as a probe. Among approximately 9,700 genomic DNA library clones of *H. polymorpha* SH4329, one positive clone was found. The plasmid harbored in this clone was extracted and subcloned into pBluescript II KS+ (STRATAGENE), resulting in plasmid pFA301. Sequencing revealed that the insert in pFA301 harbors an ORF consisting of 1,239 bp with 207-bp and 849-bp upstream and downstream regions, respectively. Having high homology with the ORFs identified in other functionally characterized  $\Delta$ 15-fatty acid desaturases (see 3.3.2 for details), the gene probably encodes  $\Delta$ 15-fatty acid desaturase. The sequence data was deposited in the DDBJ and assigned the accession number AB778509.

### **3.3.2 Identification of *HpFAD2* and *HpFAD3* genes**

Comparison of the deduced amino acid sequences encoded by *HpFAD2* and *HpFAD3* genes with other functionally characterized yeast fatty acid desaturases by multiple sequence alignment identified three conserved histidine-rich motifs at amino acid positions 108-112, 144-148 and 333-337 in putative HpFad2, and positions 121-125, 157-161 and 343-347 in putative HpFad3 (Fig. 10). Multiple sequence alignment revealed that putative HpFad2 and HpFad3 display the highest amino acid sequence homology to *Pichia pastoris*  $\Delta$ 12- and  $\Delta$ 15- fatty acid desaturases with 66% and 62% identities, respectively (Fig. 11). Moreover, the hydropathy profiles of HpFad2 and HpFad3 demonstrated that two hydrophobic domains are located in positions consistent with the potential membrane-spanning domains observed in many fatty desaturases (Fig. 12).

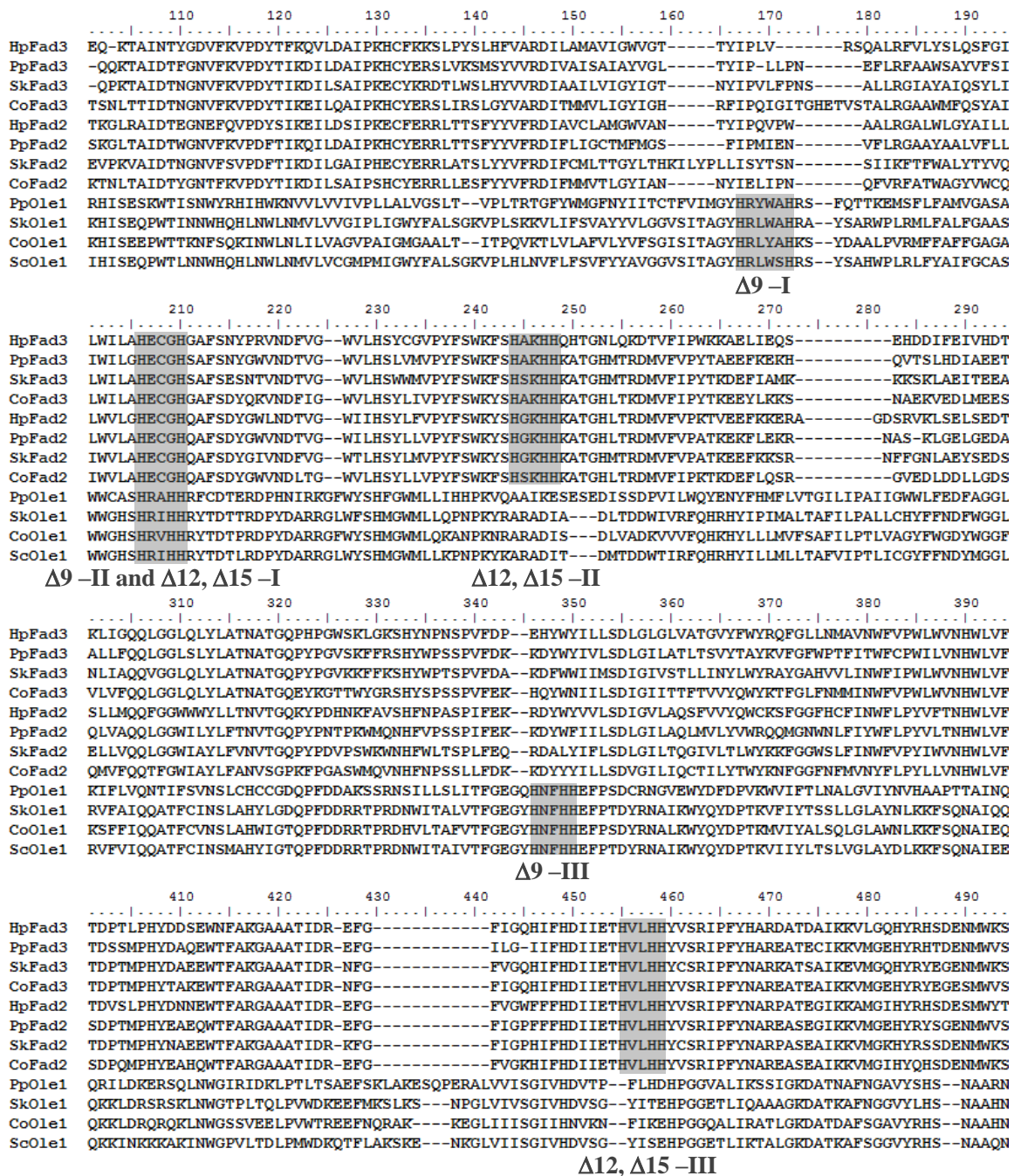

**Fig. 10** ClustalW alignment of the deduced amino acid sequences of *H. polymorpha* Δ12- (HpFad2; AB778510) and Δ15- (HpFad3; AB778509) fatty acid desaturases characterized here with Fads from other species. The putative amino acid sequences of HpFad2 and HpFad3 were aligned with other Fads including Δ9-fatty acid desaturases (Ole1) of *Pichia pastoris* (PpOle1; CCA40899), *Saccharomyces kluyveri* (SkOle1; BAB86330), *Candida orthopsilosis* (CoOle1; CCG21012) and *Saccharomyces cerevisiae* (ScOle1; AAA34826) concomitant with Δ12- and Δ15-fatty acid desaturases (Fad2 and Fad3, respectively) of *P. pastoris* (PpFad2; AAX20125, PpFad3; ABL63813), *S. kluyveri* (SkFad2; BAD08375, SkFad3; ADE06664) and *C. orthopsilosis* (CoFad2; CCG24694, CoFad3; CCG20582). Three conserved histidine-box motifs in Ole1 (Δ9-I, II and III), Fad2 (Δ12-I, II and III) and Fad3 (Δ15-I, II and III) are shaded gray.

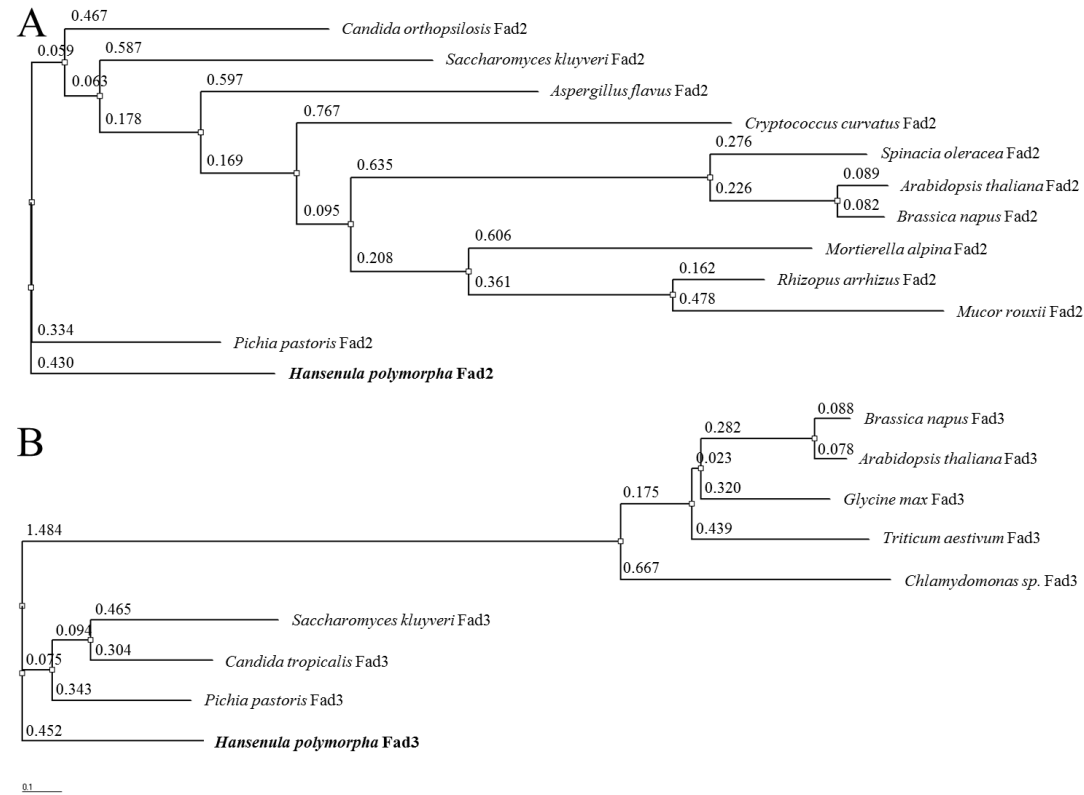

**Fig. 11** Phylogenetic tree comparing the deduced amino acid sequence of (A) *H. polymorpha*  $\Delta$ 12-fatty acid desaturase (HpFad2; AB778510) with Fad2 from other organisms including *Pichia pastoris* (GenBank ID: AAX20125), *Candida orthopsilosis* (CCG24694), *Saccharomyces kluyveri* (CAX45569), *Aspergillus flavus* (AAP33789), *Cryptococcus curvatus* (AAS78627), *Mortierella alpina* (AAL13300), *Mucor rouxii* (AAD55982), *Rhizopus arrhizus* (AAT48093), *Spinacia oleracea* (BAC22091), *Brassica napus* (ABG76201) and *Arabidopsis thaliana* (AEE75152); and (B) *H. polymorpha*  $\Delta$ 15-fatty acid desaturase (HpFad3; AB778509) with Fad3 from other organisms including *P. pastoris* (ABL63813), *C. orthopsilosis* (CCG20582), *S. kluyveri* (BAD11952), *Chlamydomonas sp.* (ACX42440), *Triticum aestivum* (BAA28358), *Glycine max* (NP\_001237507), *A. thaliana* (AEC08330) and *B. napus* (AAT09135). The trees were drawn using the Neighbor Joining algorithm with Bioedit version 7.0.5 (Hall, 1999). The horizontal line corresponds to genetic distance.

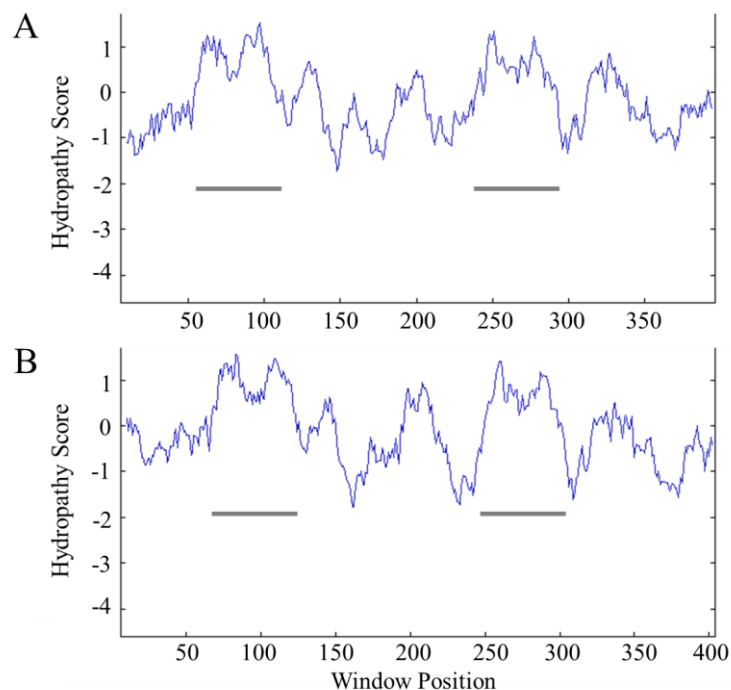

**Fig. 12** Hydropathy plot of (A) *H. polymorpha*  $\Delta$ 12-fatty acid desaturase (HpFad2; AB778510) and (B) *H. polymorpha*  $\Delta$ 15-fatty acid desaturase (HpFad3; AB778509). The plots were analyzed using the Kyte-Doolittle method. Two hydrophobic domains are indicated by bars.

### 3.3.3 Functional characterization of *HpFAD2* and *HpFAD3*

To test whether the putative *HpFAD2* gene indeed functions as a  $\Delta$ 12-fatty acid desaturase, we constructed a *H. polymorpha* strain named HR2-D57 in which *HpFAD2* was disrupted by a Zeocin cassette. Disruption of the *HpFAD2* gene of a candidate clone displaying a Zeocin-resistant phenotype was confirmed by colony PCR and Southern analysis (data not shown). Fatty acid profile analysis revealed that C18:2 fatty acids are not synthesized in the *Hpfad2* $\Delta$  disruptant; as a result,  $\alpha$ C18:3 fatty acids are also lacking (Fig. 13B; Table 7). This result suggested that *HpFAD2* indeed encodes a  $\Delta$ 12-fatty acid desaturase that functions as the only one responsible for the production of C18:2.

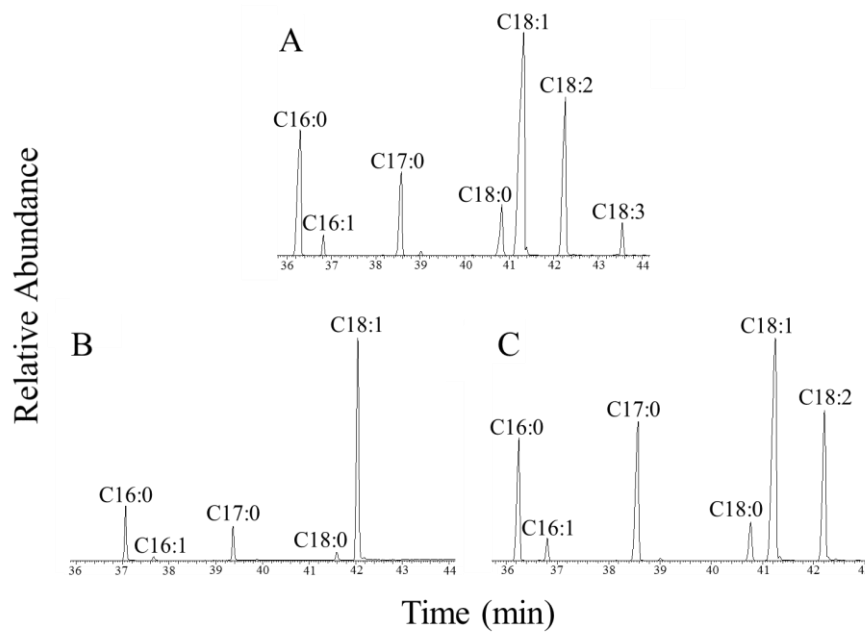

**Fig. 13** Fatty acid composition of the  $\Delta 12$ - and  $\Delta 15$ -fatty acid desaturase disruptant strains. Total fatty acids extracted from the (A) *H. polymorpha* wild-type (B) *Hpfad2* $\Delta$  disruptant HR2-D57 and (C) *Hpfad3* $\Delta$  disruptant HT3-D22 were analyzed by GC-MS as described in Materials and Methods and displayed in chromatogram. C14:0, myristic acid; C16:0, palmitic acid; C16:1, palmitoleic acid; C18:0, stearic acid; C18:1, oleic acid; C18:2, linoleic acid; C18:3,  $\alpha$ -linolenic acid.

**Table 7** Fatty acid composition of *Hpfad2* $\Delta$  disruptant

Strain	mol%					
	C16:0	C16:1	C18:0	C18:1	C18:2	C18:3
<i>H. polymorpha</i> wildtype H50-5C	22.1	1.6	6.1	32.1	32.7	3.8
<i>Hpfad2</i> $\Delta$	20.5	1.6	2.7	74.6	-	-

To investigate the function of *HpFAD3*, *HpFAD3* was disrupted by the *URA3* gene. Ura<sup>+</sup> candidates were screened and confirmed by colony PCR and Southern analysis for disruption of the *HpFAD3* gene (data not shown). *Hpfad3* $\Delta$  disruptants were subsequently subjected to GC-MS to examine the fatty acid composition. Fatty

**Table 8** Fatty acid composition of *Hpfad3* $\Delta$  disruptant

Strain	mol%					
	C16:0	C16:1	C18:0	C18:1	C18:2	C18:3
<i>H. polymorpha</i> wildtype H50-5C	19.9	1.9	6.2	47.9	21.4	2.7
<i>Hpfad3</i> $\Delta$	19.2	2.8	5.6	48.1	24.3	-

acid profile analysis suggested that *Hpfad3* $\Delta$  disruptants cannot produce  $\alpha$ C18:3 (Fig. 13C; Table 8), suggesting that the *HpFAD3* gene indeed encodes a  $\Delta$ 15-fatty acid desaturase that functions as the only one gene in the desaturation of C18:2 to produce  $\alpha$ C18:3. To confirm further the functions of *HpFAD2* and *HpFAD3*, I carried out heterologous expression of these genes in *S. cerevisiae* as described in the next section.

### 3.3.4 Heterologous expression of *HpFAD2* and *HpFAD3* genes in *S. cerevisiae*

To verify that HpFad2 and HpFad3 themselves display  $\Delta$ 12- and  $\Delta$ 15- fatty acid desaturase activities, respectively, *HpFAD2* and *HpFAD3* were expressed under the control of an inducible promoter, *GALI* promoter, in *S. cerevisiae*, which does not have intrinsic  $\Delta$ 12- and  $\Delta$ 15- fatty acid desaturase activities. *S. cerevisiae* expressing *HpFAD2* showed the existence of both C16:2 and C18:2 fatty acid species, whereas the wild-type strain without *HpFAD2* did not (Fig. 14, upper panel; Table 9). This

**Table 9** Fatty acid composition of *S. cerevisiae* expressing *HpFAD2* gene

<i>S. cerevisiae</i> SH6314 harboring	mol%						
	C16:0	C16:1	C16:2	C18:0	C18:1	C18:2	C18:3
pYES2	20.8	37.7	-	7.3	25.5	-	-
pFAD2EX	17.8	30.7	5.2	7.4	19.9	10.3	-

observation indicates that *HpFAD2* expression contributes to the production of both C16:2 and C18:2 di-unsaturated fatty acid species in *S. cerevisiae*. Likewise, the fatty acid profile of *S. cerevisiae* expressing *HpFAD3* demonstrated the presence of  $\alpha$ C18:3 when C18:2 was supplied in the media (Fig. 14, lower panel; Table 10), indicating that *HpFAD3* is responsible for the conversion of C18:2 into  $\alpha$ C18:3 tri-unsaturated fatty

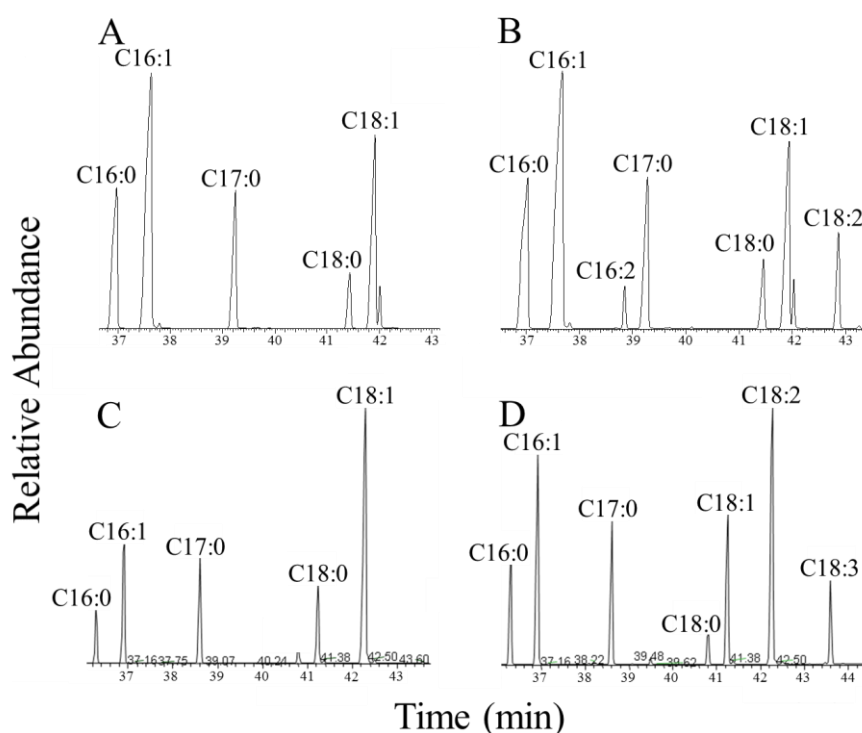

**Fig. 14** Fatty acid composition of *S. cerevisiae* expressing *HpFAD2* and *HpFAD3* under the control of an inducible promoter. (A) The fatty acid profile of *S. cerevisiae* wild-type strain SH6314 harboring pYES2, (B) *S. cerevisiae* wild-type strain SH6314 bearing pFAD2EX, (C) *S. cerevisiae* wild-type strain KYC525 harboring p520, and (D) *S. cerevisiae* wild-type strain KYC525 harboring pFAD3EX was analyzed by GC-MS as described in the Materials and methods and the chromatograms are displayed. C14:0, myristic acid; C16:0, palmitic acid; C16:1, palmitoleic acid; C18:0, stearic acid; C18:1, oleic acid; C18:2, linoleic acid; C18:3,  $\alpha$ -linolenic acid.

**Table 10** Fatty acid composition of *S. cerevisiae* expressing *HpFAD3* gene

<i>S. cerevisiae</i> KYC525 harboring	mol%						
	C16:0	C16:1	C16:2	C18:0	C18:1	C18:2	C18:3
p520	10.6	23.0	-	2.7	15.0	48.1	-
pFAD3EX	12.2	25.3	-	3.7	18.0	30.6	10.2

acid species, supporting the idea that *HpFAD3* encodes a protein that functions as a  $\Delta$ 15- fatty acid desaturase. Collectively, all of these findings indicate that *HpFAD2* and *HpFAD3* are the sole genes encoding  $\Delta$ 12- and  $\Delta$ 15- fatty acid desaturases responsible for desaturation of C18:1 into C18:2 and C18:2 into  $\alpha$ C18:3, respectively.



### 3.3.5 Identification of promoter regions of *HpFAD2* and *HpFAD3* genes

To gain insight into the regulation of fatty acid desaturases in *H. polymorpha*, I determined the nucleotide sequence of the upstream regions of fatty acid desaturase genes *HpFAD2* and *HpFAD3* by inverse PCR. Although we reported the sequence of the *HpOLE1* gene in our previous study (Lu et al. 2000), the sequences of the upstream and downstream regions of *HpOLE1* were not determined. We therefore also sequenced these regions of *HpOLE1* by inverse PCR. It has been shown that a FAR region and

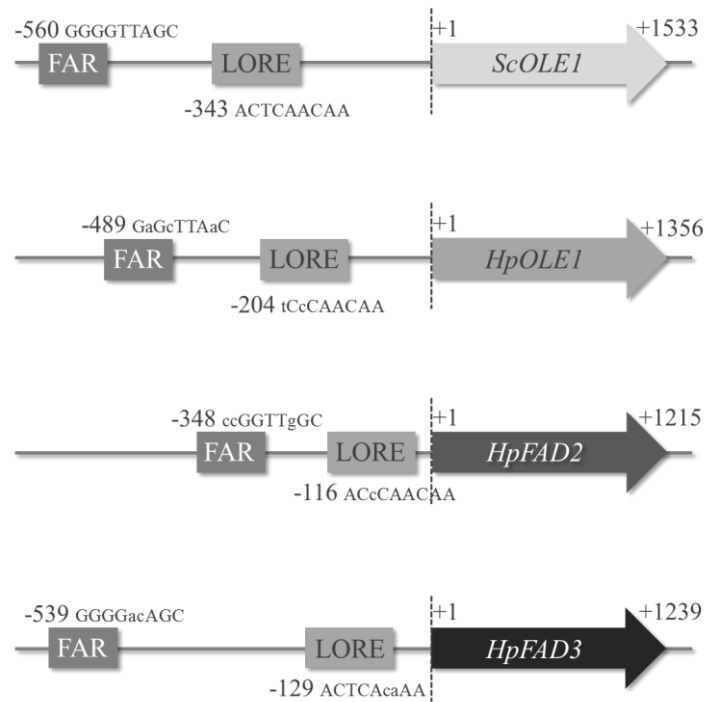

**Fig. 15** Comparative schematic representation of fatty acid desaturase genes and major features of their upstream regions including the *S. cerevisiae* Δ9-fatty acid desaturase gene (*ScOLE1*), *H. polymorpha* Δ9-fatty acid desaturase gene (*HpOLE1*), Δ12-fatty acid desaturase gene (*HpFAD2*), and Δ15-fatty acid desaturase gene (*HpFAD3*). Two principal proposed transcription activation elements are indicated, FAR, Fatty Acid Regulated region; and LORE, Low Oxygen Response Element.

LORE are involved in transcriptional regulation of the *S. cerevisiae OLE1* gene (Choi et al. 1996; Vasconcelles et al. 2001). These FAR region and LORE have the sequences 5'-GGGGTTAGC-3' and 5'-ACTCAACAA-3', which mediate transcriptional control by fatty acids and oxygen level, and are located at positions -560 and -343 upstream of the *ScOLE1* ORF, respectively. Intriguingly, sequence analysis of the inverse PCR products revealed that the upstream regions of the *HpOLE1*, *HpFAD2* and *HpFAD3* ORFs all contain FAR-like and LORE-like regions in common (Fig. 15). The FAR like regions of *HpOLE1*, *HpFAD2* and *HpFAD3* are located at positions -489, -348 and -539 upstream of the respective ORFs, whereas the LOREs of *HpOLE1*, *HpFAD2* and *HpFAD3* are positioned -204, -116 and -129 nucleotides upstream of the respective ORFs. These observations suggest that expression of the *HpFAD2* and *HpFAD3* genes may be modulated by fatty acids and oxygen at the transcriptional level, as in the case of *ScOLE1*.

### **3.3.6 Effect of low oxygen and exogenous fatty acids on *HpFAD2* and *HpFAD3* transcriptions**

As described in Section 3.3.5, LORE-like and FAR-like regions are present in the upstream regions of *HpOLE1*, *HpFAD2* and *HpFAD3*. I therefore speculated that transcription of the *HpFAD2* and *HpFAD3* genes may be modulated by fatty acids and oxygen, as in the case of *ScOLE1*. In addition, it was previously reported that *HpOLE1* transcription is slightly repressed by 1 mM C18:1 (Lu et al., 2000). Thus, the transcriptional levels of *HpFAD2* and *HpFAD3* were investigated by real-time PCR in wild-type *H. polymorpha* strain H50-5C cultured in nutrient media both under normal oxygen condition supplemented with exogenous C18:1, C18:2 or  $\alpha$ C18:3, and under

hypoxic conditions. The transcription level of both genes under hypoxic condition was more than three-fold up-regulated as compared with that under normal oxygen

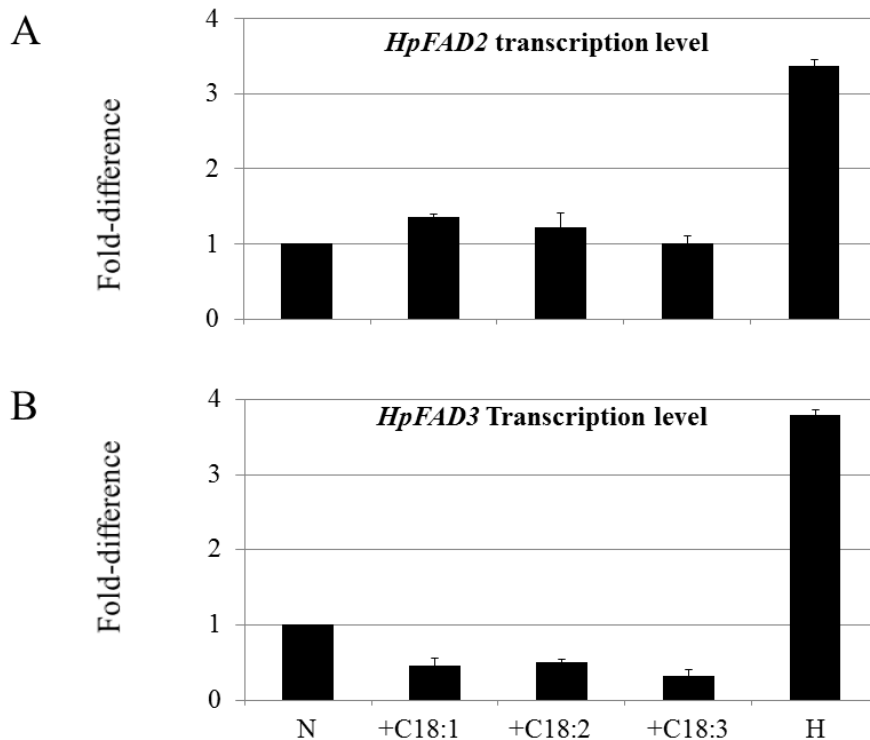

**Fig. 16** Transcriptional level of the  $\Delta$ 12- and  $\Delta$ 15-fatty desaturase genes (A) *HpFAD2* and (B) *HpFAD3* of *H. polymorpha* H50-5C cultured in nutrient media under normal oxygen conditions (N); cultured in nutrient media under normal oxygen conditions plus supplementation with exogenous C18:1 (+C18:1), C18:2 (+C18:2) or  $\alpha$ C18:3 (+C18:3); and cultured under hypoxic conditions (H). The transcription level was measured by quantitative RT-PCR. See the Material and methods for the detailed experimental conditions.

conditions (Fig 16), indicating that the expression of both *HpFAD2* and *HpFAD3* is induced by hypoxia.

Regarding transcription levels in the presence of exogenous fatty acids, unexpectedly *HpFAD2* expression did not alter on the addition of C18:1, C18:2 or  $\alpha$ C18:3 (Fig. 16A), suggesting that the transcription of this gene is not regulated by these unsaturated fatty acids. In contrast to *HpFAD2*, the *HpFAD3* transcription level decreased by approximately 50% or more upon the addition of C18:1, C18:2 or  $\alpha$ C18:3

(Fig 16B), suggesting that the transcription of *HpFAD3* is regulated by these unsaturated fatty acids.

### 3.4 Discussion

This chapter describes for the first time the identification of two fatty acid desaturase genes in *H. polymorpha* designated *HpFAD2* and *HpFAD3*. The deletion of *HpFAD2* and *HpFAD3* in *H. polymorpha* and heterologous expression of *HpFAD2* and *HpFAD3* in *S. cerevisiae* clearly demonstrated that the *HpFAD2* and *HpFAD3* genes encode  $\Delta$ 12- and  $\Delta$ 15-fatty acid desaturases responsible for the production of two major polyunsaturated fatty acid species typically found in *H. polymorpha* namely, linoleic acid (C18:2) and  $\alpha$ -linolenic acid (C18:3), respectively.

According to sequence analysis, a FAR region and LORE are present in the promoter regions of *HpFAD2* and *HpFAD3*. Martin et al. (2007) reviewed that *S. cerevisiae OLE1* gene expression is regulated by unsaturated fatty acids and oxygen at both transcriptional and mRNA stability levels. At the transcriptional level, unsaturated fatty acid-dependent repression is mediated by the FAR region (Choi et al. 1996) and hypoxic activation is mediated by the LORE (Vasconcelles et al. 2001) in *S. cerevisiae*. When unsaturated fatty acid or oxygen become limiting, Mga2/Spt23 as transcriptional activators of the FAR region and LORE-bound complex are ubiquitinated by Rsp5, an E3 ubiquitin ligase, and transported into the nucleus where they function as transcriptional activators of *OLE1* (Nakagawa et al. 2002; Scherbik et al. 2003) (Fig. 17). At the post-transcriptional level, Mga2/Spt23 also controls the half-life of *OLE1* transcripts by activating the exosomal 3'-5' exonuclease (Kandasamy et al. 2004).

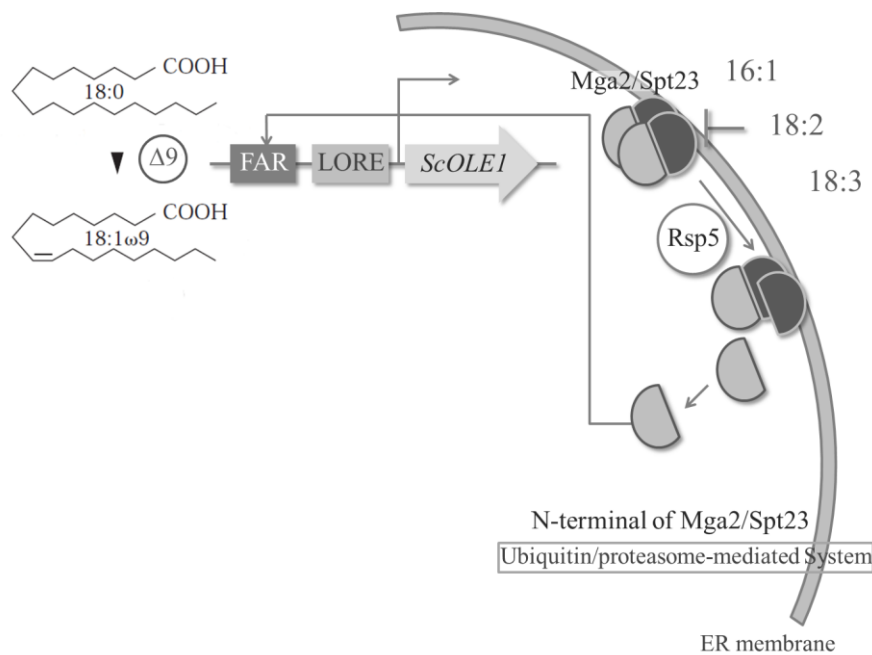

**Fig. 17** Schematic representative model controlling the *S. cerevisiae* *OLE1* gene encoding  $\Delta 9$ -fatty acid desaturase at transcriptional level in response to exogenous C16:1, C18:2 and C18:3 unsaturated fatty acids. The presence of exogenous unsaturated fatty acids inhibits ubiquitin-proteasome proteolysis of either Spt23 or Mga2 by Rsp5 E3 ubiquitin ligase, thereby restraining transcription of the *OLE1* gene.

I discovered that both *HpFAD2* and *HpFAD3* gene expressions are induced under hypoxic conditions (Fig. 16). The repression of *HpFAD3* transcription caused by the addition of unsaturated fatty acids suggests that regulation of *HpFAD3* might be primarily controlled at the transcriptional level. Whether the putative FAR region and LORE in the promoter region are involved in the regulation of *HpFAD3* remains to be determined. To date, the FAR region and LORE have not been found in the promoter region of  $\Delta 12$ - and  $\Delta 15$ -fatty acid desaturase genes in any other organisms that have these two fatty acid desaturase genes except for *S. cerevisiae* *OLE1*. In future work, the systematic construction of deletion derivatives of the promoter region of *HpFAD3* would help us unravel the molecular mechanism of regulation of fatty acid desaturase gene expression in *H. polymorpha*.

On the other hand, *HpFAD2* transcription did not change in the presence of unsaturated fatty acids (Fig. 16). Thus, what mechanisms regulate the expression of *HpFAD2*? The first possible mechanism is that HpFad2 enzyme activity may decrease when there is an excess of C18:2. The second possibility is that there may be an enhancement of HpFad2 enzyme degradation. In fact, the majority of evidence suggests that plant fatty acid desaturases are regulated primarily at the post-transcriptional level (Dyer and Mullen, 2008). For instance, studies conducted on plant Fads have shown that, although exposure of plants to low temperatures results in an increase in PUFAs to maintain proper membrane fluidity, *FAD* genes are typically not upregulated transcriptionally (Dyer et al., 2001). It has been suggested that plant Fad enzymes might be influenced by physical properties of the membrane, whereby alternations in fluidity affect stabilization of the enzyme structure or the putative degradation signal, ultimately altering the steady-state amount of Fad enzymes. Regulation of Fads at the protein level supports the idea of the homeoviscous adaptation of plant cells (O'Quin et al., 2010). In addition, because Fads are short-lived proteins, their abundance tends to change in correlation with changes in the amount of fatty acid produced (Heinemann and Ozols, 2003). Therefore, this study paves the way to consider the underlying details of the regulation of *H. polymorpha FAD2* by post-transcriptional and post-translational mechanisms, while the regulation of *H. polymorpha FAD3* might be considered primarily at a transcriptional level.

In conclusion, this study is the first report of the cloning and identification of two polyunsaturated fatty acid desaturase genes, *HpFAD2* and *HpFAD3*, along with their promoter regions, in the yeast *H. polymorpha*. The functional repertoires of these Fads were expanded by gene disruption in *H. polymorpha* and heterologous expression

in *S. cerevisiae*. This study not only provides new insight into the functions of two major polyunsaturated fatty acid desaturases, but also complements current knowledge of the molecular basis of the *H. polymorpha* fatty acid desaturation system and will inform future research toward better understanding of the regulation and biotechnological application of these enzymes.

#### 4.5 Summary

Two fatty acid desaturase genes have been cloned: *HpFAD2* and *HpFAD3* encode *H. polymorpha*  $\Delta$ 12-fatty acid desaturase (HpFad2) and  $\Delta$ 15-fatty acid desaturase (HpFad3), which are responsible for the production of linoleic acid (LA, C18:2,  $\Delta$ 9,  $\Delta$ 12) and  $\alpha$ -linolenic acid (ALA,  $\alpha$ C18:3,  $\Delta$ 9,  $\Delta$ 12,  $\Delta$ 15), respectively. The open reading frame of the *HpFAD2* and *HpFAD3* genes is 1,215 bp and 1,239 bp, encoding 405 and 413 amino acids, respectively. The putative amino acid sequences of HpFad2 and HpFad3 share more than 60% similarity and three conserved histidine-box motifs with other known yeast Fad homologs. *Hpfad2* $\Delta$  disruptant cannot produce C18:2 and  $\alpha$ C18:3 while the deletion of *HpFAD3* only causes the absence of  $\alpha$ C18:3. Heterologous expression of either the *HpFAD2* or the *HpFAD3* gene in *S. cerevisiae* resulted in the presence of C18:2 and  $\alpha$ C18:3 when the C18:2 precursor was added. Taken together, these observations indicate that *HpFAD2* and *HpFAD3* indeed encode  $\Delta$ 12- and  $\Delta$ 15- fatty acid desaturases that function as the only ones responsible for desaturation of oleic acid (C18:1) and linoleic acid (C18:2), respectively, in *H. polymorpha*. Because a Fatty Acid Regulated (FAR) region and a Low Oxygen Response Element (LORE), which are responsible for regulation of a  $\Delta$ 9-fatty acid

desaturase gene (*ScOLE1*) in *S. cerevisiae*, are present in the upstream regions of both genes, I investigated whether the transcriptional levels of *HpFAD2* and *HpFAD3* are affected by supplementation with nutrient unsaturated fatty acids or by low oxygen conditions. Both genes were up-regulated under low oxygen conditions. Only *HpFAD3* transcription was repressed by an excess of C18:1, C18:2 and C18:3 whereas the *HpFAD2* transcript level did not significantly change. These observations indicate that *HpFAD3* is primarily regulated at transcriptional level while *HpFAD2* expression is not controlled at the transcriptional level by fatty acids even though it contains a FAR-like region.



## Chapter 4

### General discussion

Over the last decades major advances have been made in the cloning and identification of genes involved in fatty acid synthesis: *de novo* biosynthesis, elongation, and desaturation from an array of different organisms. This information has helped us gain new insights into overall picture of the fatty acid biosynthetic pathway, and their physiological functions in fatty acid metabolism. Considering that unsaturated fatty acids, especially for polyunsaturated fatty acids (PUFAs), as not only key components of cellular membrane but also signaling molecules, the non-conventional yeast *H. polymorpha*, which typically produces PUFAs in addition to long-chain saturated fatty acids (LCSFAs) and monounsaturated fatty acids (MUFAs), has been adopted as a model organism to study more insights into regulation of the fatty acid synthesis in yeast. Our laboratory has accomplished the basis of molecular genetic studies on fatty acid synthesis (Kaneko et al. 2003; Nakajima 2004), elongation (Prasitchoke 2007a; 2007b) and desaturation (Anamnart et al. 1997; Lu et al. 2000) in *H. polymorpha*. In this study, I have revealed a more fulfillment of the *de novo* biosynthesis and desaturation of PUFAs in yeast.

Crystallization of yeast fatty acid synthase (Fas) has been reported for over five years (Lomakin et al., 2007); however, how Fas determine length of final fatty acid product remained unclear. To this end, I created chimeras between *H. polymorpha* (HpFas) and *S. cerevisiae* (ScFas) to unravel more refined characteristic of *H.*

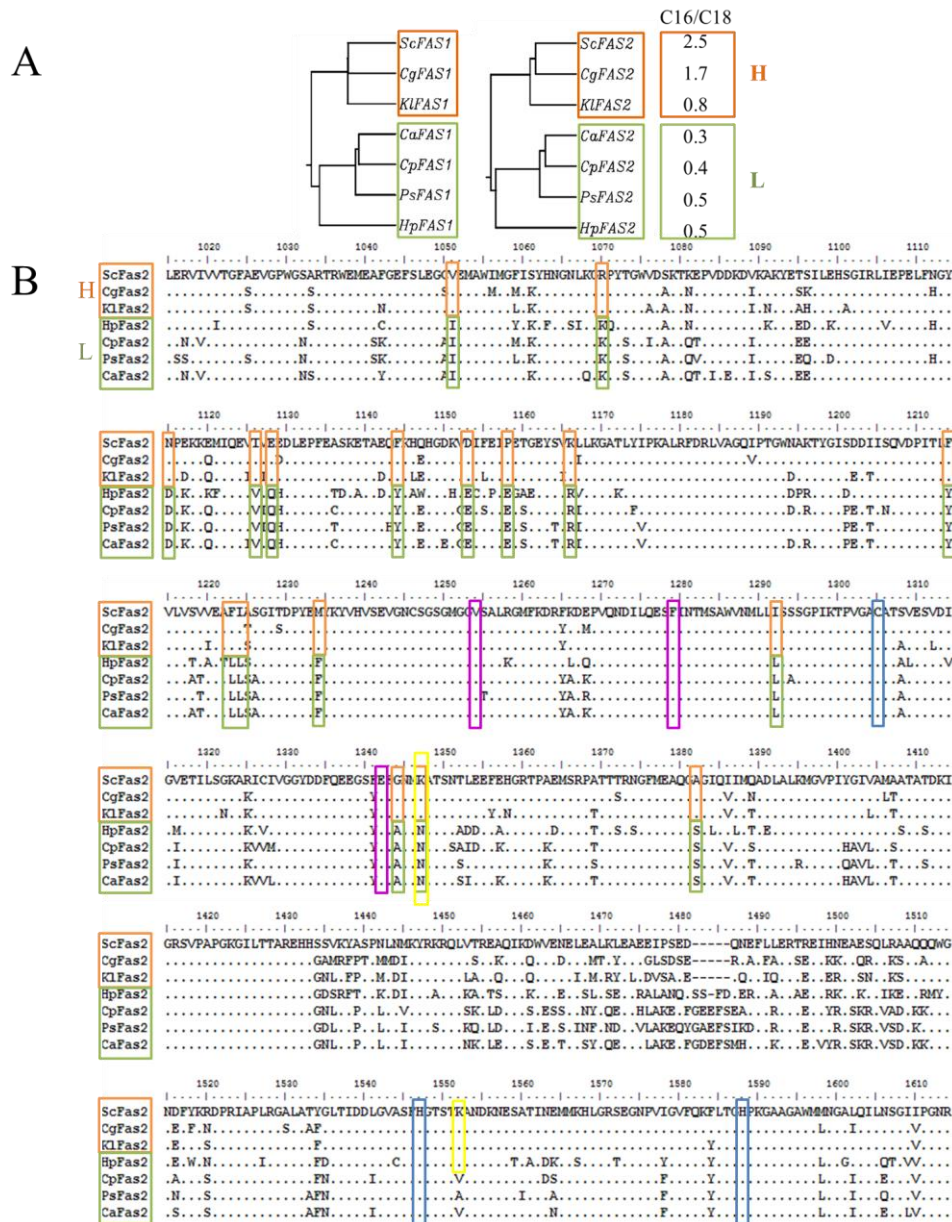

**Fig. 18** (A) Phylogenetic tree comparing the amino acid sequence of  $\beta$  subunit (left) and  $\alpha$  subunit (right) of fatty acid synthase of *Saccharomyces cerevisiae*, *Candida glabrata*, *Kluyveromyces lactis*, *Hansenula polymorpha*, *C. parapsilosis*, *Pichia stipitis* and *C. albicans*. The sequences were clustered into two groups, which also relative to grouping by their degree of C16/C18 ratio as high (H) and low (L) C16/C18 ratios, indicated in orange and green, respectively. (B) Multiple sequence alignment indicates seventeen amino acid residues in the N-terminal region of KS domain at the positions 1,051, 1,070, 1,115, 1,126, 1,128, 1,144, 1,153, 1,158, 1,166, 1,214, 1,223, 1,224, 1,234, 1,292, 1,344, 1,347 and 1,382 with respect to the *S. cerevisiae* Fas2 that are conserved in the groups. The conserved residues of yeast species with high (H) and low (L) C16/C18 ratios are shown in orange and green boxes, respectively. Amino acid residues that are part of the hydrophobic acyl binding pocket at the positions 1,254, 1,279 and 1,342 with respect to the *S. cerevisiae* Fas2 are shown in magenta boxes. The residues that form a catalytic triad responsible for decarboxylative condensation reaction at the positions 1,305, 1,542 and 1,583 with respect to the *S. cerevisiae* Fas2 are shown in blue boxes. The suspected flap residues, 1,337 and 1,541 for *H. polymorpha* Fas2 and 1,347 and 1,547 for *S. cerevisiae* Fas2, that undergo conformational changes are shown in yellow boxes.

*polymorpha* fatty acid synthase (HpFas) involved in formation of longer fatty acyl chain length. Ketoacyl synthase (KS) domain in the HpFas2 appeared to be a major determinant for longer length and a compensatory increase in unsaturated fatty acids of total fatty acids. The presence of fatty acids with longer chain length together with an increase in unsaturated fatty acids found in the HpFas hybrids corresponds to homeoviscous adaptation to maintain membrane fluidity. I questioned that the ultimate diverse length of fatty acid pools from HpFas and ScFas are probably governed by the difference in their catalytic sites on the KS. However, according to amino acid sequence alignment, active triad sites including cysteine 1,305, histidine 1,542 and histidine 1,583 in *S. cerevisiae* Fas2, as well as the lysine 1,578, which is the critical residue for decarboxylation reported in bacterial Fas, are all conserved among these two yeast species. Site-directed mutagenesis of specific amino acid residues in the KS domain would help address more particularly how the final length of fatty acid products is determined. I aligned KS domain homolog sequences from several yeast species (Fig. 18). Based on the amino acid sequences, we could cluster the sequences of yeast species relative to their degree of C16/C18 ratios (Fig. 18A), implying that there might be a relationship between amino acid sequence and C16/C18 ratio. Notably, seventeen amino acid residues on the N-terminal of KS domain (at the positions 1,051, 1,070, 1,115, 1,126, 1,128, 1,144, 1,153, 1,158, 1,166, 1,214, 1,223, 1,224, 1,234, 1,292, 1,344, 1,347 and 1,382) with respect to the *S. cerevisiae* Fas2 are conserved in the groups (Fig. 18B).

According to the crystal structure of *S.cerevisiae* Fas (Johansson et al. 2008), V1254, F1279 and E1342 are located in acyl binding tunnel. C1305, H1542 and H1583 form a catalytic triad that catalyzes the decarboxylative condensation reaction. I

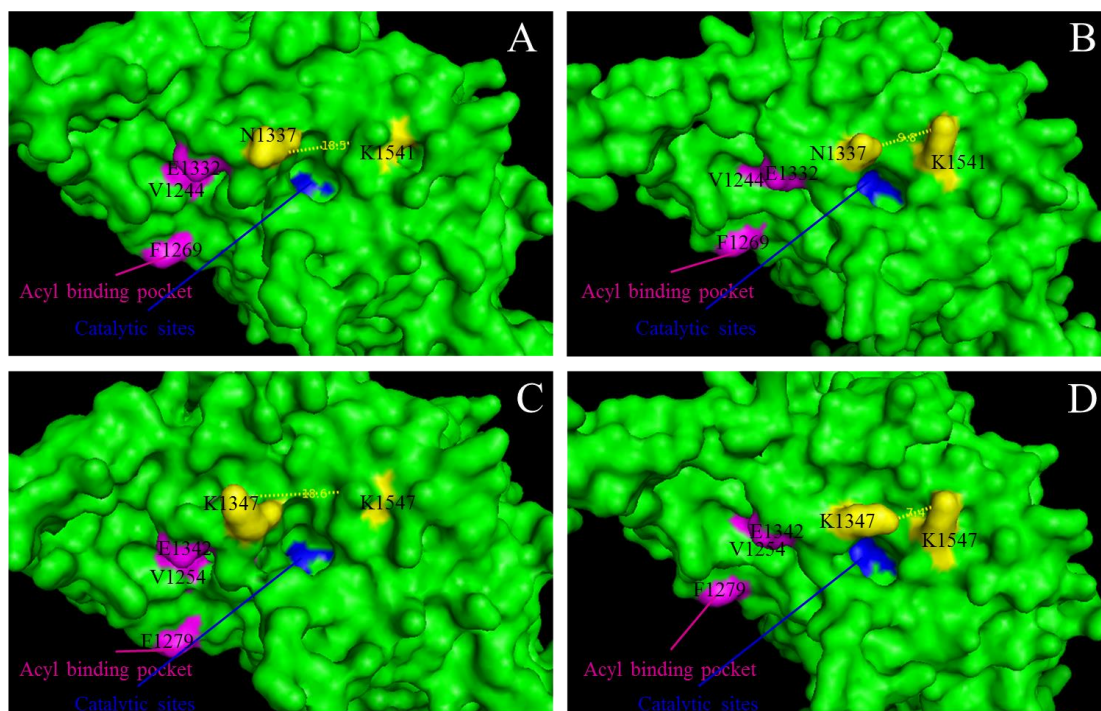

**Fig. 19** Comparison of surface representation of the open form (A) and the closed form (B) of *H. polymorpha* KS domain and the open form (C) (PDB code 2PFF) and the closed form (D) (PDB code 3HMJ) of *S. cerevisiae* KS domain. Three residues forming a catalytic triad, C1295, H1536 and H1577 for *H. polymorpha* Fas2 and C1305, H1542 and H1583 for *S. cerevisiae* Fas2, are shown in blue. Three residues that are located in an acyl chain binding pocket, E1332, V1244 and F1269 for *H. polymorpha* Fas2 and E1342, V1254 and F1279 for *S. cerevisiae* Fas2, are shown in magenta. Two suspected flap residues that perform conformational change from an open to a closed state, N1337 and K1541 for *H. polymorpha* Fas2 and K1347 and K1547 for *S. cerevisiae* Fas2, are shown in yellow. The figures were prepared using PyMOL version 1.6 (<http://www.pymol.org/>).

supposed that some of the seventeen suspected residues are supposed to interact with the fatty acyl chain or the catalytic triad. However, I found that only one amino acid residue (K1541 for *S. cerevisiae* or N1337 for *H. polymorpha*) is located near the catalytic triad while other suspected residues are far from both the acyl chain binding pocket and the catalytic triad. The K1541 for *S. cerevisiae* or N1337 for *H. polymorpha* interacts with another amino acid residue (K1547 for *S. cerevisiae* or K1347 for *H. polymorpha*), which interestingly change the conformation of the structures from an open to a closed form. The conformational change is called flap, which typically looks

like a lid to open or close the pocket to allow or prevent the entry of the substrates. I speculate that KS domain remains in open conformation (Fig. 19A and 19C) until both fatty acyl chain and malonyl moiety are transferred into the KS while the KS changes into closed form (Fig. 19B and 19D) when it is ready to condense the substrates. Comparison of 3D surface representation of *H. polymorpha* KS and *S. cerevisiae* KS either in the open form or the closed form indicates that the distances between two suspected flap residues (N1337 and K1541 for *H. polymorpha* KS, and K1347 and K1547 for *S. cerevisiae* KS) are nearly identical to each other (18.5 Å) in the open form (Fig. 19A and 19C). However, these distances are considerably different from each other in the closed form (Fig. 19B and 19D). The distances between the suspected flap residues of the closed form of *H. polymorpha* KS (9.8 Å) is larger than that of *S. cerevisiae* KS (7.4 Å). I therefore propose that the different distance of the suspected flap residues between two yeast species might be a reason why *H. polymorpha* KS allows malonyl moiety to condense with the growing chain with higher efficiency than in the case of *S. cerevisiae* KS, resulting in larger amount of longer chain length fatty acids produced by *H. polymorpha* Fas. I propose that we would consider the seventeen conserved amino acid residues, particularly N1337 for *H. polymorpha* KS and K1347 for *S. cerevisiae* KS, to perform site-direct mutagenesis to identify the amino acid residues that are responsible for the difference in the chain length of fatty acids produced by *H. polymorpha* KS and *S. cerevisiae* KS.

I present the cloning and identification of two polyunsaturated fatty acid desaturase genes, *HpFAD2* and *HpFAD3*, along with their promoter regions, from the yeast *H. polymorpha*. I found that transcriptional level of both genes is hypoxia-induced. However, only the transcriptional level of *HpFAD3*, but not *HpFAD2*, was repressed by

UFA. A major challenge for the future is to discover how the level of gene expression is controlled by both factors. As the regulation of *HpFAD3* expression is considered to operate primarily at transcription level, systematic construction of deletion derivatives of the promoter region of *HpFAD3* would help unravel the regulatory machinery of *HpFAD3* expression. On the other hand, the regulation of *HpFAD2* expression remains a challenge because we found hypoxia-induced transcription of *HpFAD2* while there is no affect by fatty acid supplementation. This suggests that the *HpFAD2* expression may be not controlled by fatty acids or controlled at post-transcriptional level. Recent studies revealed that Brassica and tung Fads are extensively regulated at post-transcriptional level by both temperature-dependent changes in translational efficiency and modulation of protein half-life mediated by proteasome-dependent protein degradation (Khuu et al., 2011).

To this end, in this thesis I propose determinant of chain length of fatty acid products from fatty acid biosynthesis, indicating a specific domain in Fas that can be a productive target for engineering synthesis of fatty acid products of specific chain length, and I also clarify current knowledge of the molecular basis of *H. polymorpha* fatty acid desaturation system through the identification of two fatty acid desaturases responsible for PUFA production. This study sheds light for future research on the main feature of regulation of fatty acid desaturases in *H. polymorpha*, which would allow fine-tuning of fatty acid biosynthetic pathway or fatty acid desaturation in response to environmental changes or for further application in future fatty acid production in yeast.

## References

- Amberg DC, Burke DJ, Stratern JN (2005) Methods in yeast genetics. Cold Spring Harbor Laboratory, Cold Spring Harbor, NY
- Anamnart S, Tomita T, Fukui F, Fujimori K, Harashima S, Yamada Y, Oshima Y (1997) The *P-OLE1* gene of *Pichia angusta* encodes a  $\Delta 9$ -fatty acid desaturase and complements the *ole1* mutation of *Saccharomyces cerevisiae*. *Gene* 184:299-306
- Anamnart S, Tolstorukov I, Kaneko Y, Harashima (1998) Fatty acid desaturation in methylotrophic yeast *Hansenula polymorpha* strain CBS1976 and unsaturated fatty acid auxotrophic mutants. *J Ferment Bioeng.* 85:476-482
- Arondel V, Lemieux B, Hwang I, Gibson S, Goodman HM, Somerville CR (1992) Map-based cloning of a gene controlling  $\omega$ -3 fatty acid desaturation in *Arabidopsis*. *Science* 258:1353-1355
- Beaudoin FL, Michaelson V, Hey SJ, Lewis MJ, Shewry PR, Sayanova O, Napier JA (2000) Heterologous reconstitution in yeast of the polyunsaturated fatty acid biosynthetic pathway. *Proc Natl Acad Sci USA.* 97:6421-6426
- Bisang C, Long PF, Cortes J, Westcott J, Crosby J, Matharu AL, Cox RJ, Simpson TJ, Staunton J, Leadlay PF (1999) A chain initiation factor common to both modular and aromatic polyketide synthases. *Nature* 401:502-505
- Blasbalg TL, Hibbeln JR, Ramsden CE, Majchrzak SF, Rawlings RR (2011) Changes in consumption of omega-3 and omega-6 fatty acids in the United States during the 20th century. *Am J Clin Nutr.* 93:950-962

- Calvo AM, Gardner HW, Keller NP (2001) Genetic connection between fatty acid metabolism and sporulation in *Aspergillus nidulans*. *J Biol Chem.* 276:25766–25774
- Celik E, Calik P (2012) Production of recombinant proteins by yeast cells. *Biotechnol Adv.* 30:1108-1118
- Certik M, Shimizu S (1999) Biosynthesis and regulation of microbial polyunsaturated fatty acid production. *J Biosci Biotechnol.* 87:1-14
- Choi JY, Stuke J, Hwang SY, Martin CE (1996) Regulatory elements that control transcription activation and unsaturated fatty acid-mediated repression of *Saccharomyces cerevisiae OLE1* gene. *J Biol Chem.* 271:3581-3589
- Cottrell M, Kock JLF, Lategan PM, Botes PJ, Britz TJ (1985) The long-chain fatty acid compositions of species representing the genus *Kluyveromyces*. *FEMS Microbiol Lett.* 30:373-376
- Das UN (2006a) Essential fatty acids- a review. *Curr Pharm Biotechnol.* 7:467-482
- Das UN (2006b) Essential fatty acids: biochemistry, physiology and pathology. *Biotechnol J.* 1:420-439
- Dijk RV, Faber KN, Kiel JAKW, Veenhuis M, Klei IVD (2000) The methylotrophic yeast *Hansenula polymorpha*: a versatile cell factory. *Enzym Microb Tech.* 26:793-800
- Dijk RV, Faber KN, Hammond AT, Glick BS, Veenhuis M, Kiel JAKW (2001) Tagging *Hansenula polymorpha* genes by random integration of linear DNA fragments (RALF). *Mol Genet Genomics.* 266: 646-656



- Dinh TN, Nagahisa K, Hirasawa T, Furusawa C, Shimizu H (2008) Adaptation of *Saccharomyces cerevisiae* Cells to High Ethanol Concentration and Changes in Fatty Acid Composition of Membrane and Cell Size. PLoS One 3:2623-2630
- Domergue F, Lerchl J, Zahringer U, Heinz E (2002) Cloning and functional characterization of *Phaeodactylum tricornutum* front-end desaturases involved in eicosapentaenoic acid biosynthesis. Eur J Biochem. 269:4105-4113
- Domergue F, Abbadì A, Ott C, Zank TK, Zahringer U, Heinz E (2003) Acyl carriers used as substrates by the desaturases and elongases involved in very long-chain polyunsaturated fatty acids biosynthesis reconstituted in yeast. J Biol Chem. 278:35115-35126
- Dowhan W, Bogdanov M, Mileykovskaya E (2008) Functional roles of lipids in membranes. In: Biochemistry of Lipids, Lipoproteins and Membranes (5<sup>th</sup> Edn.) (Vance DE and Vance JE (eds.) Elsevier Science, Amsterdam.
- Dyer JM, Chapital DC, Cary JW, Pepperman AB (2001) Chilling-sensitive, post-transcriptional regulation of a plant fatty acid desaturase expressed in yeast. Biochem Biophys Res Commun. 282:1019-1025
- Dyer JM, Mullen RT (2008) Engineering plant oils as high-value industrial feedstocks for biorefining: the need for underpinning cell biology research. Physiol Plantarum. 132:11-22
- Funk CD (2001) Prostaglandins and leukotrienes: advances in eicosanoids biology. Science 294:1871-1875
- Gellissen G, Kunze G, Gaillardin C, Cregg JM, Berardi E, Veenhuis M, Klei IVD (2005) New yeast expression platforms based on methylotrophic *Hansenula*

- polymorpha* and *Pichia pastoris* and on dimorphic *Arxula adenivorans* and *Yarrowia lipolytica*- a comparison. FEMS Yeast Res. 5:1079-1096
- Gipson P, Mills DJ, Wouts R, Grininger M, Vonck J, Kühlbrandt W (2010) Direct structural insight into the substrate-shuttling mechanism of yeast fatty acid synthase by electron cryomicroscopy. Proc Natl Acad Sci. 107:9164-9169
- Hall TA (1999) BioEdit: a user-friendly biological sequence alignment editor and analysis program for Windows 95/98/NT. Nucleic Acids Symp. Ser. 41:95-98
- Haucke V, Di Paolo G (2007) Lipids and lipid modifications in the regulation of membrane traffic. Curr Opin in Cell Biol. 19:426-435
- Heinemann FS, Ozols J (2003) Stearoyl-CoA desaturase, a short-lived protein of endoplasmic reticulum with multiple control mechanisms. Prostaglandins Leukot Essent Fatty Acids. 68:123-133
- Hooper L, Thompson RL, Harrison RA, Summerbell CD, Ness AR, Moore HJ, Worthington HV, Durrington PN, Higgins JPT, Capps NE, Riemersma RA, Ebrahim SBJ, Smith GD (2006) Risks and benefits of omega-3 fats for mortality, cardiovascular disease, and cancer: systematic review. British Med J. 332:752-760
- Hossain MA (2011) Fish as source of n-3 polyunsaturated fatty acids (PUFAs), which one is the better-farmed or wild?. Adv J Food Sci Technol. 3:455-466
- Huang YS, Chaudhary S, Thurmond JM, Bobik JrEG, Yuan L, Chan GM, Kirchner SJ, Mukerji P, Knutzon DS (1999) Cloning of  $\Delta 12$ - and  $\Delta 6$ -desaturases from *Mortierella alpina* and recombinant production of  $\gamma$ -linolenic acid in *Saccharomyces cerevisiae*. Lipids 34:649-659
- Jenni S, Leibundgut M, Maier T, Ban N (2006) Architecture of a Fungal Fatty Acid Synthase at 5 °A Resolution. Science 311:1263-1267

- Jenni S, Leibundgut M, Boehringer D, Frick C, Mikolásek B, Ban N (2007) Structure of Fungal Fatty Acid Synthase and Implications for Iterative Substrate Shuttling. *Science* 316:254-261
- Johansson P, Mulinacci B, Koestler C, Vollrath R, Oesterhelt D, Grninger M (2009) Multimeric options for the auto-activation of the *Saccharomyces cerevisiae* FAS type I megasynthase. *Structure* 17:1063-1074
- Johansson P, Wiltschi B, Kumari P, Kessler B, Vornrhein C, Vonck J, Oesterhelt D, Grninger M (2008) Inhibition of the fungal fatty acid synthase type I multienzyme complex. *Proc Natl Acad Sci USA* 35:12803-12808
- Johnson AE, van Waes MA (1999) The translocon: a dynamic gateway at the ER membrane. *Annu Rev Cell Dev Biol.* 15:799-842
- Johnson B, Brown CM (1972) A possible relationship between the fatty acid composition of yeasts and the petite mutation. *Antonie van Leeuwenhoek* 38:137-144
- Kainou K, Kamisaka Y, Kimura K, Uemura H (2006) Isolation of  $\Delta 12$  and  $\omega 3$ -fatty acid desaturase genes from the yeast *Kluyveromyces lactis* and their heterologous expression to produce linoleic and  $\alpha$ -linolenic acids in *Saccharomyces cerevisiae*. *Yeast* 23:605-612
- Kandasamy P, Vemula M, Oh CS, Chellappa R, Martin CE (2004) Regulation of unsaturated fatty acid biosynthesis in *Saccharomyces*: the endoplasmic reticulum membrane protein, Mga2p, a transcription activator of the *OLE1* gene, regulates the stability of the *OLE1* mRNA through exosome-mediated mechanisms. *J Biol Chem.* 279:36586-36592

- Kang HA, Gellissen G (2005) *Hansenula polymorpha* In: Production of recombinant proteins- novel microbial and eukaryotic expression systems. (Gellissen G), Wiley-VCH, Weinheim.
- Kaneko Y, Rueksomtawin K, Maekawa T, Harashima S (2003) Structural and functional analysis of the *FASI* gene encoding fatty acid synthase  $\beta$ -subunit in methylotrophic yeast *Hansenula polymorpha* In: Advanced research on plant lipids (Murata N, Yamada M, Nishida I, Okuyama H, Sekiya J, Wada H, eds), Kluwer Academic Publishers, London
- Khuu N, Gidda S, Shokey J M, Dyer J M, Mullen R T (2011) The N termini of Brassica and tung omega-3 fatty acid desaturases mediate proteasome-dependent protein degradation in plant cells. *Plant Signal Behav.* 6:422-425
- Kotig H, Rottner G, Beck KF, Schweizer M, Schweizer E (1991) The pentafunctional *FASI* genes of *Saccharomyces cerevisiae* and *Yarrowia lipolytica* are co-linear and considerably longer than previously estimated. *Mol Gen Genet.* 226:310-314
- Laoteng K, Ruenwai R, Tanticharoen M, Cheevadhanarak S (2005) Genetic modification of essential fatty acids biosynthesis in *Hansenula polymorpha*. *FEMS Microbiol Lett.* 245:169-178
- Lauritzen L, Hansen HS, Jurgensen MH, Michaelsen KF (2001) The essentiality of long chain n-3 fatty acids in relation to development and function of brain and retina. *Prog Lipid Res.* 40:1-94
- Leibundgut M, Jenni S, Frick C, Ban N (2007) Structural basis for substrate delivery by acyl carrier protein in the yeast fatty acid synthase. *Science* 316:288-290
- Leibundgut M, Maier T, Jenni S, Ban N (2008) The multienzyme architecture of eukaryotic fatty acid synthases. *Curr Opin Struc Biol.* 18:714-425

- Li M, Ou X, Yang X, Guo D, Qian X, Xing L, Li M (2011) Isolation of a novel C18- $\Delta$ 9 polyunsaturated fatty acid specific elongase gene from DHA-producing *Isochrysis galbana* H29 and its use for the reconstitution of the alternative  $\Delta$ 8 pathway in *Saccharomyces cerevisiae*. *Biotechnol Lett.* 33:1823-1830
- Lomakin IB, Xiong Y, Steitz TA (2007) The Crystal Structure of Yeast Fatty Acid Synthase, a Cellular Machine with Eight Active Sites Working Together. *Cell* 129:319-332
- Lu SF, Tolstorukov II, Anamart S, Kaneko Y, Harashima S (2000) Cloning, Sequencing, and Functional Analysis of *H-OLE1* Gene Encoding  $\Delta$ 9-Fatty Acid Desaturase in *Hansenula polymorpha*. *Appl Microbiol Biotechnol.* 54:499-509
- Maier T, Leibundgut M, Ban N (2008) The Crystal Structure of a Mammalian Fatty Acid Synthase. *Science* 321:1315-1322
- Maier T, Leibundgut M, Boehringer D, Ban N (2010) Structure and function of eukaryotic fatty acid synthases. *Quart Rev Biophys.* 43:373-422
- Martin CE, Oh C, Jiang Y (2007) Regulation of long chain unsaturated fatty acid synthesis in yeast. *Biochim Biophys. Acta.* 1771:271-285
- Melmer G (2005) Biopharmaceuticals and the industrial environment In: Production of recombinant proteins- novel microbial and eukaryotic expression systems. (Gellissen G), Wiley-VCH, Weinheim.
- Menyawi IE, Wögerbauer M, Sigmund H, Burgmann H, Graninger W (2000) Identification of yeast species by fatty acid profiling as measured by gas-liquid chromatography. *J Chromatogr B Biomed Sci Appl.* 742:13-24
- Meyer A, Kirsch H, Domergue F, Abbadi A, Sperling P, Bauer J, Cirpus P, Zank TK, Moreau H, Roscoe TJ, Zähringer U, Heinz E (2004) Novel fatty acid elongases and

- their use for the reconstitution of docosahexaenoic acid biosynthesis. *J Lipid Res.* 45:1899-1909
- Nakagawa Y, Sakumoto N, Kaneko Y, Harashima S (2002) Mga2p is a putative sensor for low temperature and oxygen to induce *OLE1* transcription in *Saccharomyces cerevisiae* *Biochem Biophys Res Commun* 291:707–713
- Nakajima M (2004) Identification of genes involved in fatty acid biosynthesis in the yeast *Hansenula polymorpha* by RALF method, in the Laboratory of Molecular Genetics, Bachelor's thesis, Graduate school of Engineering, Department of Biotechnology, Osaka University, Osaka
- Napier JA, Sayanova O (2005) The production of very-long-chain PUFA biosynthesis in transgenic plants: towards a sustainable source of fish oils. *Proc Nutr Soc.* 64:387-393
- Okuley J, Lightner J, Feldmann K, Yadav N, Lark E, Browse J (1994) *Arabidopsis FAD2* gene encodes the enzyme that is essential for polyunsaturated lipid synthesis. *Plant Cell.* 6:147–158
- O'Quin JB, Bourassa L, Zhang D, Shokey JM, Gidda SK, Fosnot S, Chapman KD, Mullen RT, Dyer JM (2010) Temperature-sensitive post-translational regulation of plant omega-3 fatty-acid desaturases is mediated by the endoplasmic reticulum-associated degradation pathway. *J Biol Chem.* 285:21781-21796
- Oura T, Kajiwara S (2004) *Saccharomyces kluyveri FAD3* encodes an  $\omega$ 3 fatty acid desaturase. *Microbiology* 150:1983-1990

- Oura T, Kajiwara S (2006) Cloning and functional characterization of a fatty acid synthase component *FAS2* gene from *Saccharomyces kluyveri*. *Curr Genet.* 49:393-402
- Parker-Barnes JM, Das T, Bobik E, Leonard AE, Thurmond JM, Chaung LT, Huang YS, Mukerji P (2000) Identification and characterization of an enzyme involved in the elongation of n-6 and n-3 polyunsaturated fatty acids. *Proc Natl Acad Sci USA.* 97:8284-8289
- Passorn S, Laoteng K, Rachadawong S, Tanticharoen M, Cheevadhanarak S (1999) Heterologous expression of *Mucor rouxii*  $\Delta$ 12-desaturase gene in *Saccharomyces cerevisiae*. *Biochem Biophys Res Commun.* 263:47-51
- Prasitchoke P, Kaneko Y, Bamba T, Fukusaki E, Kobayashi A, Harashima S (2007a) Identification and characterization of a very long-chain fatty acid elongase gene in the methylotrophic yeast, *Hansenula polymorpha*. *Gene* 391:16-25
- Prasitchoke P, Kaneko Y, Sugiyama M, Bamba T, Fukusaki E, Kobayashi A, Harashima S (2007b) Functional analysis of very long-chain fatty acid elongase gene, *HpELO2*, in the methylotrophic yeast *Hansenula polymorpha*. *Appl Microbiol Biotechnol.* 76:417-427
- Pscheidt B, Glieder A (2008) Yeast cell factories for fine chemical and API production. *Microb Cell Fact.* 7:25
- Qi B, Fraser T, Mugford S, Dobson G, Sayanova O, Butler J, Napier JA, Stobart AK, Lazarus CM (2004) Production of very long chain polyunsaturated omega-3 and omega-6 fatty acids in plants. *Nat Biotechnol.* 22:739-745

- Racine RA, Deckelbaum RJ (2007) Sources of very long chain unsaturated omega-3 fatty acids: Eicosapentaenoic acid and docosahexanoic acid. *Curr Opin Clin Nutr Metab Care.* 10:123-128
- Rangan VS, Smith S (2002) Fatty acid synthesis in eukaryotes. In: *Biochemistry of Lipids, Lipoproteins and Membranes* (4<sup>th</sup> Edn.) (Vance DE and Vance JE (eds.) Elsevier Science, Amsterdam.
- Ratledge C (2004) Fatty acid biosynthesis in microorganisms being used for single cell oil production. *Biochimie* 86:807-815
- Riediger ND, Othman RA, Suh M, Moghadasian MH (2009) A systematic review of the roles of n-3 fatty acids in health and disease. *J Am Diet Assoc.* 109:668-679
- Riezman H (2007) The long and short of fatty acid synthesis. *Cell* 130:587-588
- Robert SS, Singh SP, Zhou X, Petrie JR, Blackburn SI, Mansour PM, Nichols PD, Liu Q, Green AG (2005) Metabolic engineering of *Arabidopsis* to produce nutritionally important DHA in seed oil. *Func Plant Biol.* 32:473-479
- Ruiz-Lopez N, Sayanova O, Napier JA, Haslam RP (2012) Metabolic engineering of the omega-3 long chain polyunsaturated fatty acid biosynthetic pathway into transgenic plants. *J Exp Bot.* 63:2397-2410
- Russo GL (2009) Dietary n-6 and n-3 polyunsaturated fatty acids: from biochemistry to clinical implications in cardiovascular prevention. *Biochem Pharmacol.* 77:937-946
- Sakuradani E, Abe T, Iguchi K, Shimizu S (2005) A novel fungal  $\omega$ 3-desaturase with wide substrate specificity from arachidonic acid-producing *Mortierella alpina* 1S-4. *Appl Microbiol Biotechnol.* 66:648-654
- Sakuradani E, Hirano Y, Kamada N, Nojiri M, Ogawa J, Shimizu S (2004) Improvement of arachidonic acid production by mutants with lowered



- $\omega$ 3-desaturation activity derived from *Mortierella alpina* 1S-4. *Appl Microbiol Biotechnol.* 66:243-248
- Sakuradani E, Kamada N, Hirano Y, Nishihara M, Kawashima H, Akimoto K, Higashiyama K, Ogawa J, Shimizu S (2002) Production of 5,8,11-*cis*-eicosatrienoic acid by a  $\Delta$ 5 and  $\Delta$ 6 desaturation activity-enhanced mutant derived from a  $\Delta$ 12 desaturation activity-defective mutant of *Mortierella alpina* 1S-4. *Appl Microbiol Biotechnol.* 60:281-287
- Sakuradani E, Kobayashi M, Ashikari T, Shimizu S (1999) Identification of  $\Delta$ 12-fatty acid desaturase from arachidonic acid-producing *Mortierella* fungus by heterologous expression in the yeast *Saccharomyces cerevisiae* and the fungus *Aspergillus oryzae*. *Eur J Biochem.* 261:812-820
- Sakuradani E, Shimizu S (2009) Single cell oil production by *Mortierella alpina*. *J Biotechnol.* 144:31-36
- Sambrook J, Fritsch EF, Maniatis T (1989) *Molecular Cloning: A Laboratory Manual*, 2<sup>nd</sup> Ed. Cold Spring Harbor Laboratory, Cold Spring Harbor. NY
- Scherbik N, Zoladek T, Nickels JT, Haines DS (2003) Rsp5 is required for ER bound Mga2p120 polyubiquitination and decrease of the processed/tethered transactivator Mga2p90. *Curr Biol.* 13:1227-1233
- Schulz H (2008) Oxidation of fatty acids in eukaryotes. In: *Biochemistry of Lipids, Lipoproteins and Membranes* (5<sup>th</sup> Edn.) (Vance DE and Vance JE (eds.) Elsevier Science, Amsterdam.
- Schweizer E, Hofmann J (2004) Microbial Type I Fatty Acid Synthases (FAS): Major Players in a Network of Cellular FAS Systems. *Microbiol Molec Biol Rev.* 68:501-517

- Schweizer E, Kotig H, Regler R, Rottner G (1988) Genetic control of *Yarrowia lipolytica* fatty acid synthetase biosynthesis and function. J Basic Microbiol. 28:283-292
- Schweizer M, Roberts L M, Hotke HJ, Takabayashi K, Holerer E, Hoffmann B, Muler G, Kotig H, Schweizer E (1986) The pentafunctinal *FAS1* gene of yeast: its nucleotide sequence and order of the catalytic domains. Mol Gen Genet. 203:479-486
- Schweizer E, Werkeneister K and Jain MK (1978) Fatty acid biosynthesis in yeast. Mol Cell Biochem. 21:95-106
- Shimizu S, Kawashima H, Akimoto K, Shinmen Y, Yamada H (1988) Microbial conversion of an oil containing  $\gamma$ -linolenic acid to an oil containing eicosapentaenoic acid. J Am Oil Chem Soc. 66:342-347
- Shimizu S, Kawashima H, Akimoto K, Shinmen Y, Yamada H (1989) Conversion of linseed oil to an eicosapentaenoic acid-containing oil by *Mortierella alpina* 1S-4 at low temperature. Appl Microbiol Biotechnol. 32:1-4
- Shimizu S, Sakuradani E, Ogawa J (2003) Production of functional lipids by microorganisms: arachidonic acid and related polyunsaturated fatty acids, and conjugated fatty acids. Oleoscience 3:129-139
- Southard SB, Cihlar RL (1995) Analysis and expression of the *Candida albicans* *FAS2* gene. Gene 156:133-138
- Tapiero H, Nguyen Ba G, Couvreur P, Tew KD (2002) Polyunsaturated fatty acids (PUFA) and eicosanoids in human health and pathologies. Biomed Pharmacother. 56:215-222

- Tehlivets O, Scheuringer K, Kohlwein SD (2007) Fatty acid synthesis and elongation in yeast. *Biochim Biophys Acta*. 1771:255-270
- Uemura H (2012) Synthesis and production of unsaturated and polyunsaturated fatty acids in yeast: current state and perspectives. *Appl Microbiol Biotechnol*. 95:1-12
- Vance DE, Vance JE (2002) *Biochemistry of Lipids, Lipoprotein and Membrane*. 4<sup>th</sup> Edn. Elsevier Science. BV.
- Vasconcelles MJ, Jiang Y, McDaid K, Gilooly L, Wretzel S, Porter DL, Martin CE, Goldberg MA (2001) Identification and characterization of a low oxygen response element involved in the hypoxic induction of a family of *Saccharomyces cerevisiae* genes. Implications for the conservation of oxygen sensing in eukaryotes. *J Biol Chem*. 276:14374-14384
- Venegas-Calación M, Sayanova O, Napier J (2010) An alternative to fish oils: Metabolic engineering of oil-seed crops to produce omega-3 long chain polyunsaturated fatty acids. *Prog. Lipid Res*. 49:108-119
- Vrinten P, Wu G, Truksa M, Qiu X (2007) Production of polyunsaturated fatty acids in transgenic plants. *Biotechnol Genet Eng Rev*. 24:263-280
- Wang J, Zhang B, Chen S (2011) Oleaginous yeast *Yarrowia lipolytica* mutants with a disrupted fatty acyl-CoA synthetase gene accumulate saturated fatty acid. *Process Biochem*. 46:1436-1441
- Watanabe K, Oura T, Sakai H, Kajiwara S (2004) Yeast  $\Delta 12$  fatty acid desaturase: gene cloning, expression, and function. *Biosci Biotechnol Biochem*. 68:721-727
- Wei DSH, Li MCH, Zhang XX, Zhou H, Xing LJ (2006) A novel  $\Delta 12$ -fatty acid desaturase gene from methylotrophic yeast *Pichia pastoris* GS115. *Acta Biochimica Polonica*. 53:753-759

- White SW, Zheng J, Zhang YM, Rock CO (2005) The structural biology of type II fatty acid biosynthesis. *Annu Rev Biochem* 74:791–831
- Wongsumpanchai W, Anamnart S, Laoteng K, Petsom A (2004) Elongation of C16:0 to C18:0 fatty acids in methylotrophic yeast *Hansenula polymorpha* CBS 1976 and fatty acid auxotrophic mutants. *FEMS Microbiol Lett.* 237:213-218
- Yadav NS, Wierzbicki A, Aegerter M, Caster CS, Perez-Grau L, Kinney AJ, Hitz WD, Booth JrJR, Schweiger B, Stecca KL, Allen SM, Blackwell M, Reiter RS, Carlson TJ, Russel SH, Feldmann KA, Pierce J, Browse J (1993) Cloning of higher plant  $\omega$ 3 fatty acid desaturases. *Plant Physiol.* 103:467-476
- Yazawa H, Iwahashi H, Kamisaka Y, Kimura K, Uemura H (2009) Production of polyunsaturated fatty acids in yeast *Saccharomyces cerevisiae* and its relation to alkaline pH tolerance. *Yeast* 26:167-184
- Yazawa H, Iwahashi H, Kimura K, Aki T, Ono K, Uemura H (2007) Heterologous production of dihomog- $\gamma$ -linolenic acid in *Saccharomyces cerevisiae*. *Appl Environ Microbiol.* 73:6965-6971
- Yazawa H, Kamisaka Y, Kimura K, Yamaoka M, Uemura H (2011) Efficient Accumulation of Oleic Acid in *Saccharomyces cerevisiae* caused by expression of rat elongase 2 gene (*rELO2*) and Its Contribution to Tolerance to Alcohols. *Appl Microbiol Biotechnol.* 91:1593-1600
- You KM, Rosenfield C, Knipple DC (2003) Ethanol tolerance in the yeast *Saccharomyces cerevisiae* is dependent on cellular oleic acid content. *Appl Environ Microbiol.* 69:1499-1503

Zhang X, Li M, Wei D, Xing L (2008) Identification and characterization of a novel yeast  $\omega$ 3-fatty acid desaturase acting on long-chain n-6 fatty acid substrates from *Pichia pastoris*. *Yeast* 25:21-27

Zhao XJ, Cihlar RL (1994) Isolation and sequence of the *Candida albicans* *FAS1* gene. *Gene* 147:119-124

## List of publications

**Juthaporn Sangwallek**, Yoshinobu Kaneko, Minetaka Sugiyama, Hisayo Ono, Takeshi Bamba, Eiichiro Fukusaki and Satoshi Harashima. (2013) Ketoacyl synthase domain is a major determinant for fatty acyl chain length in *Saccharomyces cerevisiae*. **Arch Microbiol.** 195:843-852

**Juthaporn Sangwallek**, Yoshinobu Kaneko, Tomoya Tsukamoto, Makoto Marui, Minetaka Sugiyama, Hisayo Ono, Takeshi Bamba, Eiichiro Fukusaki and Satoshi Harashima. (2014) Cloning and functional analysis of *HpFAD2* and *HpFAD3* genes encoding  $\Delta$ 12- and  $\Delta$ 15-fatty acid desaturases in *Hansenula polymorpha*. **Gene** 533:110-118

## Acknowledgements

My first gratitude goes out to Professor Dr. Satoshi Harashima for allowing me to be his student. It has been the best opportunity for me to learn under your kind supervision. You have always supported and given me every effort to make me be a good scientist. As words escape me, I cannot express enough appreciation for all your invaluable guidance and thoughtful help that you have provided me. Also, I would like to express my sincere thanks to Professor Dr. Yoshinobu Kaneko, my direct advisor, for supervising me throughout my research. I am truly thankful for all your technical expertise, fruitful discussion and advice that you have provided me. I am grateful to Associate Professor Dr. Minetaka Sugiyama as well for giving me always your kind support and generosity. My thanks is also extended to Assistant Professor Dr. Yu Sasano for all your valuable comments. And my special thanks is expressed to Associate Professor Dr. Hiromi Maekawa for your entire technical expert that you have suggested me. My great appreciation is also Prof. Dr. Takuya Nihira and Prof. Dr. Toshiya Muranaka for theirs valuable comments as my committees.

My special gratitude to Professor Dr. Ei-ichiro Fukusaki, Associate Professor Dr. Takeshi Bamba and Assistant Professor Dr. Hisayo Ono for their assistance in the experiment of GC-MS analysis including all worthy guidance and helpful comments.

My appreciation is also Prof. Dr. Shigenori Kanaya and Ms. Sintawee Sulaiman for their valuable suggestion and guidance on using software for protein researches.

I would like to thank my colleagues, especially Mr. Marui Makoto and Mr. Tomoya Tsukamoto, and all Harashima lab members for being sounding boards of ideas. I really appreciate our friendship; both good-time and trouble moment we have shared.

I also would like to acknowledge the Japanese Government for making this study possible through MONBUKAGAKUSHO Scholarship.

Lastly, I am also greatly indebted to my parents and my dearest Philphil for all their love, encouragement, and support.