

Title	The parallel version of the polynomial invariants of links
Author(s)	村上, 順
Citation	大阪大学, 1989, 博士論文
Version Type	VoR
URL	https://hdl.handle.net/11094/386
rights	
Note	

Osaka University Knowledge Archive : OUKA

<https://ir.library.osaka-u.ac.jp/>

Osaka University

The parallel version of polynomial
invariants of links

村上 順

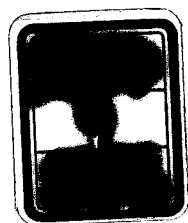

The Parallel Version of Polynomial Invariants of Links

Dedicated to Professor Nagayoshi Iwahori on his sixtieth birthday

Jun Murakami

* This research was supported in part by Grant-in-Aid for Scientific Research, The Ministry of Education, Science and Culture.

Introduction

Let \mathfrak{L} be the set of link isotopy types and $X: \mathfrak{L} \rightarrow \mathbb{C}$ a \mathbb{C} -valued invariant of links. For any positive integer r , one can define the r -parallel version $X^{(r)}: \mathfrak{L} \rightarrow \mathbb{C}$ of X by putting

$$X^{(r)}(K) = X(K^{(r)}), \quad K \in \mathfrak{L},$$

where $K^{(r)}$ is the r -parallel link of K obtained by applying the operation $\phi^{(r)}$ (see Figure 1) to each crossing point of K .

Figure 1

Recently, Morton-Short [24] and Yamada [34] independently noticed the existence of a pair of knots which is indistinguishable by the Jones polynomial [14], but is distinguishable by its 2-parallel version. Moreover there exist mutant knots distinguishable by the 3-parallel version of the two-variable Jones polynomial $P^{(3)}$ ([25] and Section 6.2 of this paper). Thus it seems to be worth while studying the r -parallel version of a link invariant from a general view-point.

Throughout this paper we assume that all the invariants of links are of 'trace' type. A link invariant X is called of trace type iff X satisfies the following conditions: (i) Let \hat{b} be the closure of an n -braid b . Then $X(\hat{b})$ can be written as a linear combination of characters of representations of the braid group B_n . (ii) The characters in (i) satisfy some compatibility conditions with respect to the natural inclusion $B_n \rightarrow B_{n+1}$ ($n=1, 2, \dots$) (see Definition 1.1.4). For example, the (two-variable) Jones polynomial [7], [14], [29] and the Kauffman polynomial [17], [22] fulfill this assumption. (See also [2], [10], [15], [26].) The purpose of this paper is to give an efficient

method to calculate the r -parallel version $X^{(r)}$ of the invariant X . A direct calculation of $X^{(r)}(K)$ is, in principle, possible, but the degrees of the characters of the representations included soon become enormous even for relatively small r . We show that the characters can be reduced to a sum of those of much smaller degrees, and we have only to deal with representation matrices of much smaller sizes. See Table 1.

Table 1

One of the main results of this paper is the following, which is an immediate consequence of Theorems 1.4.9, 1.5.1, 4.4.1, Corollary 4.2.3 and (4.1.10).

Theorem. Let V be the one-variable Jones polynomial, r a positive integer and b a 3-braid whose closure is a knot. Then we have the following.

$$V^{(r)}(b^{\wedge}) = \sum_{j=0}^{\lfloor \frac{r}{2} \rfloor} c_{r,j} \left(\sum_{i=0}^{\lfloor \frac{3(r-j)}{2} \rfloor} a_{3(r-j),i}(V) \text{Trace}(\pi_{3(r-j),i}(b)) \right),$$

where

$$c_{r,j} = \frac{r-2j+1}{r+1} \binom{r+1}{j},$$

$$a_{k,i}(V) = (-1)^{k+1} \frac{t^{k/2+1/2-i} - t^{-k/2-1/2+i}}{t - t^{-1}},$$

and $\pi_{3r,i}$ are representations of B_3 given in Theorem 4.4.1.

The degree of the representation $\pi_{3r,i}$ is equal to $i+1$ if $0 \leq i \leq r$ and $3r-2i+1$ if otherwise. Applications of the above theorem are given in (4.4.4)-(4.4.10).

In the last section of this paper, we shall give a necessary condition for the existence of mutant knots distinguishable by the r -parallel version $X^{(r)}$ of the link invariant X (Theorem 6.2.4). We construct mutant knots K_1, K_2, K_3, K_4 for which the 3-parallel version $P^{(3)}(K_i)$ ($1 \leq i \leq 4$) of the two-variable Jones polynomial are all distinct (Section 6.2).

We shall give a formula for an invariant of cable links. Let X be a link invariant of trace type. Then we shall construct several link invariants $X^{(r,1)}, X^{(r,2)}, \dots$ by 'decomposing' the r -parallel version $X^{(r)}$ of X (Theorems 1.5.1 and 2.2.1). Let K be a knot, L a link in the solid torus and K_L the satellite link [4] coming from K and L . Let X_L be a knot invariant defined by $X_L(K) = X(K_L)$. Then X_L can be written as a linear combinations of invariants $X^{(r,1)}, X^{(r,2)}, \dots$ if L is a 'cable' (Definition 1.6.3), or if X is the Jones polynomial or the Kauffman polynomial (Theorem 1.6.4, 2.2.1, 4.3.2, 5.3.1).

We prove, in Sections 1-2, fundamental formulas for $X^{(r)}$ and show some related results of general nature. In Sections 3-5 we apply the results of Sections 1-2 to the r -parallel version of the (two-variable) Jones polynomial and the Kauffman polynomial, and investigate them more closely. It is discussed in Section 6 how $X^{(r)}$ works at mutant knots.

As a conclusion of this paper, we might say that the r -parallel version of link invariants seems to be quite promising in attacking the classification problem of link types.

Acknowledgement. I would like to thank S. Yamada for the useful discussions including the results of [34], which is the motivation of this study. I would like to express my appreciation to N. Iwahori who suggested that the matrix entries given in Theorem 3.3.1 might be expressed by Gauss' polynomial, and to T. Kanenobu who informed me about pairs of closed 3-braids with the same Kauffman polynomial. I am profoundly indebted to A. Gyoja who gave me a lot of useful information about the Iwahori algebras (or Hecke algebras), for example, the result of [10]. I am also indebted to T. Kobayashi who introduced me to the theory of the (two-variable) Jones polynomial. I am very grateful to N. Kawanaka, H. Nagao, K. Nagatomo, M. Nakaoka and M. Ochiai for their useful advice and kind encouragement. Last of all, I must thank muSIMP/muMATH (Symbolic Mathematics Package), TURBO Pascal for MS-DOS on the personal computer PC-9801 (NEC) and AOS/VS Pascal on Eclipse MV/2000DC (Deta General) which are used for the calculations in the proof of Proposition 4.4.10 and in Example 6.2.7.

1. The parallel version of link invariants, I (the case of knots).

We shall discuss in this and next sections general properties of a 'parallel version' of a link invariant of 'trace' type. In this section we first state and prove the results in the case of knots, and, in Section 2, generalize them to the case of links.

1.1. Link invariants of trace type. Let B_n be Artin's braid group on n -strings with standard generators $\sigma_1, \sigma_2, \dots, \sigma_{n-1}$ as in Figure 2,

Figure 2

i.e.

$$B_n = \langle \sigma_1, \sigma_2, \dots, \sigma_{n-1} \mid \sigma_i \sigma_{i+1} \sigma_i = \sigma_{i+1} \sigma_i \sigma_{i+1} \ (1 \leq i \leq n-2), \\ \sigma_i \sigma_{i+1} = \sigma_{i+1} \sigma_i \ (1 \leq i < j-1 \leq n-2) \rangle.$$

Let $\xi_n^{(r)}: B_n \rightarrow B_{n+r}$ be the group homomorphism defined by $\xi_n^{(r)}(\sigma_i) = \sigma_i$ for $n, r \in \mathbb{N} = \{1, 2, \dots\}$ and $1 \leq i \leq n-1$. We regard B_n as a subgroup of B_{n+r} with respect to the inclusion $\xi_n^{(r)}$. Let $B = \{(b, n) \mid b \in B_n \text{ for } n=1, 2, \dots\}$. A closure of a braid (b, n) , written $(b, n)^\wedge$ or simply b^\wedge , is the link formed by joining the n points at the top of (b, n) to those at the bottom without further crossings. Two links K_1, K_2 are called equivalent if K_1 is ambient isotopic to K_2 in \mathbb{R}^3 ([3], Chapt. 1, B).

Theorem 1.1.1 (Alexander [1] p.42). Every link is equivalent to the closure of a braid.

Definition 1.1.2 (Markov class). Let \sim be the equivalence relation on B generated by the following:

$$(i) \quad (bb', n) \sim (b'b, n) \quad \text{for } b, b' \in B_n,$$

$$(ii) \quad (b, n) \sim (b\sigma_n^{\pm 1}, n+1) \quad \text{for } b \in B_n.$$

The equivalence classes of B by the above relation are called Markov classes.

Theorem 1.1.3 (Markov [1] p.51). The closures of two braids b_1, b_2 are equivalent if and only if b_1 and b_2 are contained in the same Markov class.

Definition 1.1.4 (link invariant). A mapping X from B to a set S is called a link invariant if X is constant on each Markov class of B .

Let C be the field of complex numbers and B_n^\wedge the set of equivalence classes of finite dimensional irreducible C -linear representations of B_n . Let f be a C -valued function on B . We assume that f can be written as a linear combination of characters of the braid group, i.e. for $b \in B_n$,

$$(1.1.5) \quad f(b, n) = \sum_{\mu \in B_n^\wedge} a_\mu(f) \chi_\mu(b),$$

where, for each $\mu \in B_n^\wedge$, χ_μ is the corresponding character and $a_\mu(f)$ is an element of C independent of b . Let (ρ_μ, V_μ) be the representation of B_n corresponding to $\mu \in B_n^\wedge$, i.e. V_μ is the representation space and ρ_μ is the group homomorphism from B_n to

$GL(V_\mu)$. Then ρ_μ is extended uniquely to a \mathbb{C} -algebra homomorphism from the group ring CB_n to $End(V_\mu)$ and so its character χ_μ is extended to a linear function on CB_n , which are also denoted by ρ_μ and χ_μ respectively. Hence the function f is extended to a function on $CB = \{(b, n) \mid b \in CB_n \text{ for } n \in \mathbb{N}\}$ by (1.1.5), which is also denoted by f .

Definition 1.1.6 (associated algebra). Let $A_n(f)^\wedge = \{\mu \in B_n^\wedge \mid$

$\rho_\mu(f) \neq 0\}$ for $n \in \mathbb{N}$ and $A_n(f) = \bigoplus_{\mu \in A_n(f)^\wedge} \rho_\mu(CB_n)$. We call $A_n(f)$

($n=1, 2, \dots$) the associated algebra of f . Let $p_n : CB_n \rightarrow A_n(f)$ be the

algebra homomorphism defined by $p_n = \bigoplus_{\mu \in A_n(f)^\wedge} \rho_\mu$.

Definition 1.1.7 (trace type). A \mathbb{C} -valued function f on B is called of trace type if f satisfies the following conditions:

- (i) The invariant f can be written as a linear combination of characters of B_n as in (1.1.5).
- (ii) Let $A_1(f), A_2(f), \dots$ be the associated algebras of f . Then there are algebra homomorphisms $\zeta_n : A_n(f) \rightarrow A_{n+1}(f)$ for which

$$p_{n+1} \circ \zeta_n^{(1)} = \zeta_n \circ p_n.$$

Remark 1.1.8. Either the one(two)-variable Jones polynomial or the Kauffman polynomial is of trace type for the generic values of its parameter(s).

To specify the notations, we review the definitions of the polynomial invariants of links mentioned in Remark 1.1.8. We also recall the definitions of the regular isotopy invariants of unoriented link diagrams called the bracket polynomial and the L-polynomial [16], [17] which will be needed in Sections 2 and 3.

Definition 1.1.9 (writhe). The writhe of a link diagram K is the sum of the signatures of all crossing points of K (Figure 3) and is denoted by $w(K)$.

Figure 3

Definition 1.1.10. Fix a non-zero complex number t . The bracket polynomial $\langle \cdot \rangle = \langle \cdot \rangle(t)$ with values in \mathbb{C} is uniquely defined for regular isotopy classes of the unoriented link diagrams by the following formulas:

$$\langle K_+ \rangle = t^{-1/4} \langle K_0 \rangle + t^{1/4} \langle K_\infty \rangle, \quad \langle O \rangle = 1 \quad \text{for the unknot } O,$$

where the K_* are identical except within a ball where they are as in Figure 4.

Figure 4

Fix non-zero complex numbers a and x . The D-polynomial $D(\cdot) = D(\cdot)(a, x)$ with values in \mathbb{C} is uniquely defined for regular isotopy classes of the unoriented link diagrams by the following formulas:

$$D(K_+) - D(K_-) = x(D(K_0) - D(K_\infty)),$$

$$D(K_{\ell^+}) = a D(K_\cap), \quad D(K_{\ell^-}) = a^{-1} D(K_\cap), \quad D(O) = 1,$$

where the K_* are identical except within a ball where they are as in

Figure 4.

In the following, we define isotopy invariants of oriented links. Fix a non-zero complex number t . The one-variable Jones polynomial $V(\cdot) = V(\cdot)(t)$ with values in \mathbb{C} is defined by

$$(1.1.11) \quad t^{-1}V(K_+) - tV(K_-) = (t^{1/2} - t^{-1/2})V(K_0), \quad V(O) = 1,$$

where the K_x are identical except within a ball where they are as in Figure 5. To specify the parameter t , we also denote $V(K)$ by $V(K)(t)$ for a link K . Let K be a link diagram. Then it is known [16] that

$$(1.1.12) \quad V(K)(t) = (-t^{3/4})^{w(K)} \langle |K| \rangle (t).$$

Figure 5

Fix non-zero complex numbers ℓ and m . The two-variable Jones polynomial $P(\cdot) = P(\cdot)(\ell, m)$ with values in \mathbb{C} is defined by

$$\ell^{-1}P(K_+) + \ell P(K_-) + mP(K_0) = 0, \quad P(O) = 1,$$

where we use the notation in (1.1.11).

Fix non-zero complex numbers a and x . Let K be a link diagram and $|K|$ its unoriented link diagram. The Kauffman polynomial $F(\cdot) = F(\cdot)(a, x)$ with values in \mathbb{C} is defined by $F(K) = a^{-w(K)} D(|K|)$.

1.2. Parallel versions. Fix a positive integer r . Let $\phi_n^{(r)}: B_n \rightarrow B_{rn}$ be the group homomorphism defined by Figure 1, or, equivalently, by

$$(1.2.1) \quad \phi_n^{(r)}(\sigma_i) = \sigma_{(ri-r+1, ri-1)}^{-r} \sigma_{(ri, ri+r-1)} \sigma_{(ri-1, ri+r-2)} \dots \sigma_{(ri-r+1, ri)} \\ (1 \leq i \leq n-1),$$

where $\sigma(i, j) = \sigma_i \sigma_{i+1} \dots \sigma_j$. Let $\phi^{(r)}: B \rightarrow B$ be the map defined by $\phi^{(r)}((b, n)) = (\phi_n^{(r)}(b), rn)$.

Theorem 1.2.2. Let (b_1, n_1) and (b_2, n_2) be two braids. Then the links $(\phi_{n_1}^{(r)}(b_1), rn_1)^\wedge$ and $(\phi_{n_2}^{(r)}(b_2), rn_2)^\wedge$ are equivalent if $(b_1, n_1)^\wedge$ and $(b_2, n_2)^\wedge$ are equivalent.

The following lemma and Theorem 1.1.3 yield the above theorem.

Lemma 1.2.3. Let \sim denote the Markov equivalence relation (Definition 1.1.2). Then we have the following:

(a) For $b_1, b_2 \in B_n$, $(\phi_n^{(r)}(b_1 b_2), rn) \sim (\phi_n^{(r)}(b_2 b_1), rn)$,

(b) For $b \in B_n$, $(\phi_n^{(r)}(b), rn) \sim (\phi_{n+1}^{(r)}(b \sigma_n^{\pm 1}), rn+r)$.

Proof. The part (a) holds since $\phi_n^{(r)}$ is a group homomorphism. The following Lemma 1.2.4 shows the part (b). \square

Lemma 1.2.4. For $b \in B_n$ ($n \geq r$),

$$(1.2.5) \quad (b, n) \sim (b\sigma_n^{(r)}, n+r),$$

$$(1.2.6) \quad (b, n) \sim (b(\sigma_n^{(r)})^{-1}, n+r).$$

where $\sigma_n^{(r)} = \sigma(n-r+1, n-1)^{-r} \sigma(n, n+r-1) \sigma(n-1, n+r-2) \dots \sigma(n-r+1, n)$.

Proof. We first prove (1.2.5) by induction on r . For $r=1$, (1.2.5) is identical to Definition 1.1.2 (ii). Suppose that (1.2.5) is true for $r=k-1$. By Definition 1.1.2 (i) and (ii) we have

$$\begin{aligned} (1.2.7) \quad & (b\sigma_n^{(k)}, n+k) \\ & \sim (\sigma(n-1, n+k-2) \dots \sigma(n-k+1, n) b \sigma(n-k+1, n-1)^{-k} \sigma(n, n+k-2) \sigma_{n+k-1, n+k}) \\ & \sim (\sigma(n-1, n+k-2) \dots \sigma(n-k+1, n) b \sigma(n-k+1, n-1)^{-k} \sigma(n, n+k-2), n+k-1) \\ & \sim (b \sigma(n-k+1, n-1)^{-k} \sigma(n, n+k-2) \sigma(n-1, n+k-2) \dots \sigma(n-k+1, n), n+k-1). \end{aligned}$$

By using the relation of the braid group, we have $\sigma_k^{-1} \sigma(i, j)^{-1} = \sigma(i, j)^{-1} \sigma_{k+1}^{-1}$, and so we get

$$\begin{aligned} (1.2.8) \quad & \sigma(n-k+1, n-1)^{-k+1} \\ & = \sigma(n-k+2, n-1)^{-1} \sigma_{n-k+1}^{-1} \sigma(n-k+1, n-1)^{-k+2} \\ & = \sigma(n-k+2, n-1)^{-1} \sigma(n-k+1, n-1)^{-k+2} \sigma_{n-1}^{-1} \\ & = \sigma(n-k+2, n-1)^{-2} \sigma_{n-k+1}^{-1} \sigma(n-k+1, n-1)^{-k+3} \sigma_{n-1}^{-1} \\ & = \sigma(n-k+2, n-1)^{-2} \sigma(n-k+1, n-1)^{-k+3} \sigma_{n-2}^{-1} \sigma_{n-1}^{-1} \\ & = \dots = \sigma(n-k+2, n-1)^{-k+1} \sigma_{n-k+1}^{-1} \sigma_{n-k+2}^{-1} \dots \sigma_{n-1}^{-1}. \end{aligned}$$

By using the relation of the braid group, we have $\sigma(i, j)\sigma(i-1, j) = \sigma(i-1, j)\sigma(i-1, j-1) = \sigma_{i-1}\sigma(i, j)\sigma(i-1, j-1)$. Hence we get

$$\begin{aligned}
 (1.2.9) \quad & \sigma(n, n+k-2)\sigma(n-1, n+k-2)\sigma(n-2, n+k-3) \dots \sigma(n-k+1, n) \\
 & = \sigma_{n-1}\sigma(n, n+k-2)\sigma(n-1, n+k-3)\sigma(n-2, n+k-3) \dots \sigma(n-k+1, n) \\
 & = \sigma_{n-1}\sigma_{n-2}\sigma(n, n+k-2) \dots \sigma(n-2, n+k-4)\sigma(n-3, n+k-4) \dots \sigma(n-k+1, n) \\
 & = \dots = \sigma_{n-1}\sigma_{n-2} \dots \sigma_{n-k+1}\sigma(n, n+k-2) \dots \sigma(n-k+1, n-1).
 \end{aligned}$$

By substituting (1.2.8) and (1.2.9) to (1.2.7), we obtain

$$\begin{aligned}
 & (b\sigma_n^{(r)}, n+k) \\
 & \sim (b\sigma(n-k+1, n-1)^{-k}\sigma(n, n+k-2)\sigma(n-1, n+k-2) \dots \sigma(n-k+1, n), n+k-1) \\
 & = (b\sigma(n-k+1, n-1)^{-1}\sigma(n-k+2, n-1)^{-k+1}\sigma_{n-k+1}^{-1}\sigma_{n-k+2}^{-1} \dots \sigma_{n-1}^{-1} \\
 & \quad \sigma_{n-1}\sigma_{n-2} \dots \sigma_{n-k+1}\sigma(n, n+k-2) \dots \sigma(n-k+2, n-1)\sigma(n-k+1, n-2), n+k-1) \\
 & = (b\sigma(n-k+1, n-1)^{-1}\sigma(n-k+2, n-1)^{-k+1} \\
 & \quad \sigma(n, n+k-2) \dots \sigma(n-k+2, n-1)\sigma(n-k+1, n-1), n+k-1) \\
 & = (b\sigma(n-k+1, n-1)^{-1}\sigma_n^{(k-1)}\sigma(n-k+1, n-1), n+k-1).
 \end{aligned}$$

Moreover, Lemma 1.2.3 (a) and the induction hypothesis imply that

$$(b\sigma(n-k+1, n-1)^{-1}\sigma_n^{(k-1)}\sigma(n-k+1, n-1), n+k-1) \sim (b, n).$$

Hence (1.2.5) is proved. An analogous argument yields (1.2.6). \square

Definition 1.2.10 (r-parallel version). Let K be a link and $(b, n) \in B$ the braid whose closure is equivalent to K . The link $(\phi_n^{(r)}(b), n)^\wedge$ is called the r-parallel version of K and denoted by $K^{(r)}$. The r-parallel version $f^{(r)}$ of a function f on B is defined by $f^{(r)}(b, n) = f(\phi_n^{(r)}(b), rn)$.

The r-parallel version of a link is well-defined by Theorem 1.2.2. Hence the parallel version $X^{(r)}$ of a link invariant X is again a link invariant.

1.3. Wreath products. We review representation theory of wreath products. The references are [19] and [6]. Throughout this paper, a semigroup means that with a unit, a semigroup homomorphism means that which preserves the unit and a linear representation of a group or a semigroup means that which sends the unit to the identity transformation. Let $\Omega = \{1, 2, \dots, n\}$, H a semigroup with a semigroup homomorphism $\theta: H \rightarrow S_n$, where S_n denote the symmetric group of degree n acting on Ω naturally. For $h \in H$, let $\langle \theta(h) \rangle$ denote the subgroup of S_n generated by $\theta(h)$. Fix a group G and an element h_0 of H .

$$(1.3.1) \quad H(h_0) = \{h \in H \mid \text{for every } \langle \theta(h_0) \rangle\text{-orbit } O \text{ of } \Omega, \theta(h) \cdot O = O\},$$

which is a subsemigroup of H . The semigroup $H(h_0)$ acts on G^n by the following. For $h \in H(h_0)$ and $g = (g_1, g_2, \dots, g_n) \in G^n$, $h \cdot g = (g_{\theta(h)^{-1}(1)}, \dots, g_{\theta(h)^{-1}(n)})$.

Definition 1.3.2. The set $G^n \times H(h_0)$ together with the composition law $(g, h)(g', h') = (g(\theta(h)g'), hh')$ is a semigroup called the wreath product $G^n \rtimes H(h_0)$ of G with $H(h_0)$.

For a group G let \hat{G} denote the set of equivalence classes of finite dimensional \mathbb{C} -linear irreducible group representations of G , and for $V \in \hat{G}$, (ρ_V, V_V) denotes the corresponding representation. For $V = (V_1, \dots, V_n)$ ($V_j \in \hat{G}$), let $\rho_V = \rho_{V_1} \otimes \dots \otimes \rho_{V_n}$, which is an element of $(\hat{G}^n)^\wedge$. In the following, we assume that $V_i = V_j$ if $\langle \theta(h_0) \rangle \cdot i = \langle \theta(h_0) \rangle \cdot j$. We define an action of the semigroup $G^n \rtimes H(h_0)$ on V_V by the following: For $(g, h) \in G^n \rtimes H(h_0)$ and $(v_1, \dots, v_n) \in V_{V_1} \otimes \dots \otimes V_{V_n}$,

$$(g, h)(v_1, \dots, v_n) = \rho_V(g)(v_{\theta(h)^{-1}(1)}, \dots, v_{\theta(h)^{-1}(n)}).$$

We denote by ρ_V^- the representation of the semigroup $G^n \rtimes H(h_0)$ given by the above action on V_V . If $\rho_V(g) = (\rho_{V_1}(g_1)_{\alpha_1 \beta_1} \cdots \rho_{V_n}(g_n)_{\alpha_n \beta_n})$ ($1 \leq \alpha_1, \beta_1 \leq \dim V_{V_1}, \dots, 1 \leq \alpha_n, \beta_n \leq \dim V_{V_n}$) is the matrix representing $g = (g_1, \dots, g_n) \in G^n$, then we get for $h \in H(h_0)$:

$$(1.3.3) \quad \rho_V^-(g, h) = (\rho_{V_1}(g_1)_{\alpha_1 \beta_{\theta(h)^{-1}(1)}} \cdots \rho_{V_n}(g_n)_{\alpha_n \beta_{\theta(h)^{-1}(n)}}).$$

Let π be a representation of the semigroup $H(h_0)$. By composing the canonical projection $G^n \rtimes H(h_0) \rightarrow H(h_0)$, π is naturally extended to a representation of the semigroup $G^n \rtimes H(h_0)$, which will also be denoted by π .

Proposition 1.3.4. Let (ρ, V) be a finite dimensional linear representation of the semigroup $G^n \rtimes H(h_0)$ such that the restriction $\rho|_{G^n}$ is a completely reducible group representation. We assume that the irreducible components of $\rho|_{G^n}$ are all equivalent to ρ_V . Then there is a representation π of the semigroup $H(h_0)$ such that ρ is equivalent to $\rho_V^- \otimes \pi$.

This is a version of a standard result found, e.g., in [6], Theorem 51.7. Although G^n may not be a finite group or $H(h_0)$ may not be a group, an argument analogous to the proof of [loc.cit.] works because of our assumptions, i.e. the finite dimensionality of V and the complete reducibility of $\rho|_{G^n}$.

1.4. The characters associated with the parallel version. Fix a \mathbb{C} -valued function f on B of trace type and r a positive integer. The r -parallel version $f^{(r)}$ of f is also of trace type since we have the following from (1.1.5).

$$(1.4.1) \quad f^{(r)}((b, n)^\wedge) = \sum_{\mu \in \hat{A}_{rn}(f)} a_\mu(f) \chi_\mu(\phi_n^{(r)}(b)).$$

We decompose the characters $\chi_\mu \circ \phi_n^{(r)}$ ($\mu \in \hat{A}_{rn}(f)^\wedge$) into sums of characters of B_n of smaller degrees. We need some preparations. Let $\iota_j: CB_r \rightarrow CB_{rn}$ ($1 \leq j \leq n$) be the homomorphism defined by

$$(1.4.2) \quad \iota_j(\sigma_i) = \sigma_{i+rj-r} \quad (1 \leq i \leq r-1)$$

and $\iota: CB_r^{\otimes n} \rightarrow CB_{rn}$ the homomorphism defined by $\iota(b_1 \otimes \dots \otimes b_n) = \iota_1(b_1) \dots \iota_n(b_n)$ for $b_j \in CB_r$, where $CB_r^{\otimes n}$ denotes the n -fold tensor product $CB_r \otimes \dots \otimes CB_r$ of CB_r . We regard $CB_r^{\otimes n}$ as a subalgebra of CB_{rn} by the inclusion ι . Let θ be the group homomorphism from B_n to the symmetric group S_n of degree n defined by $\theta(\sigma_i) = (i \ i+1)$ (the transposition of i and $i+1$). We define an action of B_n on $\Omega = \{1, \dots, n\}$ by $b(i) = \theta(b)(i)$ for $i \in \Omega$. Then we have the following.

Lemma 1.4.3. For $b \in B_n$ and $b' \in B_r$,

$$\phi_n^{(r)}(b) \iota_k(b') = \iota_{b(k)}(b') \phi_n^{(r)}(b) \quad (1 \leq k \leq n).$$

Proof. The following formulas imply the statement of the lemma.

$$(1.4.4.a) \quad \phi_n^{(r)}(\sigma_i) \iota_k(\sigma_j) = \iota_k(\sigma_j) \phi_n^{(r)}(\sigma_i) \quad (1 \leq i \leq n-1, 1 \leq j \leq r-1, k \neq i, i+1),$$

$$(1.4.4.b) \quad \phi_n^{(r)}(\sigma_i) \iota_{i+1}(\sigma_j) = \iota_i(\sigma_j) \phi_n^{(r)}(\sigma_i) \quad (1 \leq i \leq n-1, 1 \leq j \leq r-1),$$

$$(1.4.4.c) \quad \phi_n^{(r)}(\sigma_i) \iota_i(\sigma_j) = \iota_{i+1}(\sigma_j) \phi_n^{(r)}(\sigma_i) \quad (1 \leq i \leq n-1, 1 \leq j \leq r-1).$$

The formula (1.4.4.a) is a consequence of (1.2.1) and the relations $\sigma_i \sigma_j = \sigma_j \sigma_i$ ($|i-j| \geq 2$). We prove (1.4.4.b). Let $\sigma'(i, j) = \sigma_i \sigma_{i-1} \dots \sigma_j$ ($i \geq j$). Then

$$\phi_n^{(r)}(\sigma_i) = \sigma(\text{ri-r+1, ri-1})^{-r} \sigma'(\text{ri, ri-r+1}) \sigma'(\text{ri+1, ri-r+2}) \dots \sigma'(\text{ri+r-1, ri}).$$

Since the relations of the braid group imply $\sigma'(i, j) \sigma_k = \sigma_{k-1} \sigma'(i, j)$ ($i > k \geq j$), we have

$$\begin{aligned} & \phi_n^{(r)}(\sigma_i) \iota_{i+1}(\sigma_j) \\ &= \sigma(\text{ri-r+1, ri-1})^{-r} \sigma'(\text{ri, ri-r+1}) \sigma'(\text{ri+1, ri-r+2}) \dots \sigma'(\text{ri+r-1, ri}) \sigma_{\text{ri+j}} \\ &= \sigma(\text{ri-r+1, ri-1})^{-r} \sigma_{\text{ri-r+j}} \sigma'(\text{ri, ri-r+1}) \sigma'(\text{ri+1, ri-r+2}) \dots \sigma'(\text{ri+r-1, ri}). \end{aligned}$$

We also know ([1], p.28, Corollary 1.8.4) that the element $\sigma(\text{ri-r+1, ri-1})^{-r}$ is contained in the center of the subgroup $\langle \sigma_{\text{ri-r+1}}, \sigma_{\text{ri-r+2}}, \dots, \sigma_{\text{ri-1}} \rangle$ of B_{rn} . Hence we have

$$\phi_n^{(r)}(\sigma_i) \iota_{i+1}(\sigma_j) = \sigma_{\text{ri-r+j}} \phi_n^{(r)}(\sigma_i) = \iota_i(\sigma_j) \phi_n^{(r)}(\sigma_i).$$

This proves (1.4.4.b). The formula (1.4.4.c) is proved analogously by using

$$\phi_n^{(r)}(\sigma_i) = \sigma(\text{ri-r+1, ri-1})^{-r} \sigma(\text{ri, ri+r-1}) \sigma(\text{ri-1, ri+r-2}) \dots \sigma(\text{ri-r+1, ri})$$

and the relations $\sigma(i, j) \sigma_k = \sigma_{k+1} \sigma(i, j)$ ($i \leq k < j$). \square

Lemma 1.4.3 implies that the subgroup $\iota(B_r^n) \phi_n^{(r)}(B_n)$ of B_{rn} is isomorphic to the wreath product $B_r^n \rtimes B_n$ with respect to $\theta: B_n \rightarrow S_n$.

Definition 1.4.5 (isotypic subspace). Let A be a semisimple algebra over C , U an A -module and ρ an irreducible representation of A . An A -submodule W of U is called the ρ -isotypic subspace if and only if W is the maximal subspace on which the action of A is isomorphic to $\rho \oplus \dots \oplus \rho$ (n -times) for some $n=0, 1, 2, \dots$.

For $v(1), \dots, v(n) \in A_r(f)^\wedge$ and $\mu \in A_{rn}(f)^\wedge$, let $V_{\mu, v(1), \dots, v(n)}$ be the $\rho_{v(1)} \otimes \dots \otimes \rho_{v(n)}$ -isotypic subspace of V_μ as a B_r^n -module and $Y = V_{v(1)} \otimes \dots \otimes V_{v(n)}$. Then $V_{\mu, v(1), \dots, v(n)} \cong Y \oplus \dots \oplus Y \cong Y \otimes C^{d(\mu, v(1), \dots, v(n))}$, where $d(\mu, v(1), \dots, v(n))$ denote the multiplicity of $\rho_{v(1)} \otimes \dots \otimes \rho_{v(n)}$ in $\rho_\mu|_{B_r^n}$. For $b \in B_n$, $(b'_1, \dots, b'_n) \in B_r^n$ and $v_1 \otimes \dots \otimes v_n \otimes w \in V_{v(1)} \otimes \dots \otimes V_{v(n)} \otimes C^{d(\mu, v(1), \dots, v(n))} = V_{\mu, v(1), \dots, v(n)}$, we have

$$\begin{aligned}
 (1.4.6) \quad & \rho_\mu(\iota(b'_1 \otimes \dots \otimes b'_n) \phi_n^{(r)}(b))(v_1 \otimes \dots \otimes v_n \otimes w) \\
 &= \rho_\mu(\phi_n^{(r)}(b) \iota(b'_{b(1)} \otimes \dots \otimes b'_{b(n)}))(v_1 \otimes \dots \otimes v_n \otimes w) \\
 &= \rho_\mu(\phi_n^{(r)}(b))(\rho_{v(1)}(b'_{b(1)})v_1 \otimes \dots \otimes \rho_{v(n)}(b'_{b(n)})v_n \otimes w),
 \end{aligned}$$

from (1.4.3). The above formula implies the following:

Lemma 1.4.7. For $b \in B_n$, the subspace $\rho_\mu(\phi_n^{(r)}(b))V_{\mu, \nu(1), \dots, \nu(n)}$ is equal to the $\rho_{\nu(b^{-1}(1))} \otimes \dots \otimes \rho_{\nu(b^{-1}(n))}$ -isotypic subspace $V_{\mu, \nu(b^{-1}(1)), \dots, \nu(b^{-1}(n))}$ of V_μ .

In particular, $V_{\mu, \nu, \dots, \nu}$ is invariant relative to the action of $\iota(B_r^n) \phi_n^{(r)}(B_n)$. Let $\rho_{\mu, \nu}$ be the representation of $\iota(B_r^n) \phi_n^{(r)}(B_n)$ obtained by restricting ρ_μ on $V_{\mu, \nu, \dots, \nu}$ and $\chi_{\mu, \nu}$ its character. Then we have the following.

Proposition 1.4.8. For $b' \in B_r$ and $b \in B_n$ such that b^\wedge is a knot, we have

$$\chi_\mu(\iota_1(b') \phi_n^{(r)}(b)) = \sum_{\mu \in A_r(f)} \chi_{\mu, \nu}(\iota_1(b') \phi_n^{(r)}(b)).$$

Proof. Recall that f is of trace type. The condition (ii) of Definition 1.1.7 implies that there are algebra homomorphisms $\iota_i^\sim : A_r(f) \rightarrow A_{rn}(f)$ ($1 \leq i \leq n$) such that $\iota_i^\sim \circ p_r = p_{rn} \circ \iota_i$. Hence the action of B_r^n on V_μ is factored by $p_r^n : B_r^n \rightarrow A_r(f)^n$. Since $A_r(f)$ is the associated algebra of f , A_r is completely reducible and so we have $V_\mu = \bigoplus_{n \in (A_r(f))^n} V_{\mu, \nu(1), \dots, \nu(n)}$. Lemma 1.4.7 implies that

$$\rho_\mu(\iota_1(b') \phi_n^{(r)}(b))V_{\mu, \nu(1), \dots, \nu(n)} = \rho_\mu(\iota_1(b'))V_{\mu, \nu(b^{-1}(1)), \dots, \nu(b^{-1}(n))} =$$

$V_{\mu, \nu(b^{-1}(1)), \dots, \nu(b^{-1}(n))}$. Hence if $V_{\mu, \nu(1), \dots, \nu(n)} \neq V_{\mu, \nu(b^{-1}(1)), \dots, \nu(b^{-1}(n))}$, then the diagonal part of the matrix $\iota_1(b') \phi_n^{(r)}(b)$ corresponding to the subspace $V_{\mu, \nu(1), \dots, \nu(n)}$ is equal to 0. Thus $\chi_\mu(\iota_1(b') \phi_n^{(r)}(b))$ is equal

to the sum of the diagonal elements of $\rho_{\mu}(\iota_1(b')\phi_n^{(r)}(b))$ corresponding to the subspaces $V_{\mu, \nu(1), \dots, \nu(n)}$ with $V_{\mu, \nu(1), \dots, \nu(n)} = V_{\mu, \nu(b^{-1}(1)), \dots, \nu(b^{-1}(n))}$. Since the closure of b is a knot, $\theta(b)$ is an n -cycle. Thus $\nu(i) = \nu(b^{-1}(i))$ ($1 \leq i \leq n$) imply $\nu(1) = \dots = \nu(n)$. But the sum of diagonals of $\rho_{\mu}(\iota_1(b')\phi_n^{(r)}(b))$ on $V_{\mu, \nu, \dots, \nu}$ is equal to $\chi_{\mu, \nu}(\iota_1(b')\phi_n^{(r)}(b))$. This proves the proposition. \square

Since $\iota(B_r^n)\phi_n^{(r)}(B_n)$ is isomorphic to $B_r^n \rtimes B_n$, we see, from Proposition 1.3.4, that there is a representation $\pi_{\mu, \nu}$ of B_n such that

$$(1.4.9) \quad \rho_{\mu, \nu} \cong (\rho_{\nu}^{\otimes n})^{-} \otimes \pi_{\mu, \nu}$$

where $(\rho_{\nu}^{\otimes n})^{-}$ is the representation of $\iota(B_r^n)\phi_n^{(r)}(B_n)$ coming from the representation $\rho_{\nu}^{\otimes n}$ of B_r^n as in Proposition 1.3.4. Let χ_{ν}^{-} , $\omega_{\mu, \nu}$ be the characters of $(\rho_{\nu}^{\otimes n})^{-}$, $\pi_{\mu, \nu}$ respectively. Now we can state our main theorem.

Theorem 1.4.10. Let b be an n -braid whose closure is a knot.
Then we have the following.

$$(i) \quad \chi_{\mu}(\phi_n^{(r)}(b)) = \sum_{\nu \in A_r(f)^{\wedge}} \chi_{\nu}(1) \omega_{\mu, \nu}(b),$$

$$(ii) \quad f^{(r)}(b, n) = \sum_{\mu \in A_{rn}(f)^{\wedge}} \left(\sum_{\nu \in A_r(f)^{\wedge}} a_{\mu}(f) \chi_{\nu}(1) \omega_{\mu, \nu}(b) \right).$$

Proof. Proposition 1.4.8 and (1.4.9) yield that

$$\chi_{\mu}(\phi_n^{(r)}(b)) = \sum_{V \in A_r(f)^\wedge} \chi_{\mu, V}(\phi_n^{(r)}(b)) = \sum_{V \in A_r(f)^\wedge} \chi_V^{-}(\phi_n^{(r)}(b)) \omega_{\mu, V}(b).$$

Hence the first formula is an immediate consequence of the following lemma with $b'=1$. The second one is obtained from (i) and (1.4.1). \square

Lemma 1.4.11. For $b' \in B_r$ and $b \in B_n$ such that b^\wedge is a knot, we have

$$\chi_V^{-}(\iota_1(b')\phi_n^{(r)}(b)) = \chi_V(b').$$

Proof. By using 1.3.3, we have

$$\begin{aligned} & \chi_V^{-}(\iota_1(b')\phi_n^{(r)}(b)) \\ &= \sum_{\alpha_1, \beta_1, \dots, \alpha_n, \beta_n} \delta_{\alpha_1 \beta_1 \dots \alpha_n \beta_n} (\rho_V(b')_{\alpha_1 \beta_{b^{-1}(1)}} \rho_V(1)_{\alpha_2 \beta_{b^{-1}(2)}} \dots \rho_V(1)_{\alpha_n \beta_{b^{-1}(n)}}) \\ &= \sum_{\alpha_1, \beta_1, \dots, \alpha_n, \beta_n} \delta_{\alpha_1 \beta_1 \dots \alpha_n \beta_n} (\rho_V(b')_{\alpha_1 \beta_{b^{-1}(1)}} \delta_{\alpha_2 \beta_{b^{-1}(2)}} \dots \delta_{\alpha_n \beta_{b^{-1}(n)}}). \end{aligned}$$

Since b^\wedge is a knot and so $\theta(b)$ is an n -cycle, each term of the above summation is 0 except when $\alpha_1 = \beta_{b^{-1}(1)} = \alpha_{b^{-1}(1)} = \dots = \alpha_{b^{-n+1}(1)} = \beta_1$, i.e. $\alpha_1, \dots, \alpha_n, \beta_1, \dots, \beta_n$ are all equal. Hence we have

$$\chi_V^{-}(\iota_1(b')\phi_n^{(r)}(b)) = \sum_{\alpha_1} \rho_V(b')_{\alpha_1 \alpha_1} = \chi_V(b').$$

This completes the proof. \square

1.5. A decomposition of $X^{(r)}$ into invariants. For a C -valued function f on B of trace type, let

$$f^{(r,v)}(b, n) = \sum_{\mu \in A_{rn}(f)^\wedge} a_\mu(f) \omega_{\mu, v}(b).$$

The r -parallel version $X^{(r)}$ of a link invariant X of trace type is a sum of invariants $X^{(r,v)}$ parametrized by $A_r(X)^\wedge$:

Theorem 1.5.1. For a C -valued function f on B of trace type and $b \in B_n$, we have the following.

(i) $f^{(r,v)}$ is a link invariant if f is a link invariant.

(ii) $f^{(r)}(K) = \sum_{v \in A_r(f)^\wedge} \chi_v(1) f^{(r,v)}(K)$ for a knot K .

Proof. (ii) is an immediate consequence of the definition of $f^{(r,v)}$ and Theorem 1.4.10 (ii). To show (i), we check the invariance of $f^{(r,v)}$ relative to the relations (i), (ii) of Definition 1.1.2. Let b and b' be elements of B_n . Since $\omega_{\mu, v}(bb') = \omega_{\mu, v}(b'b)$, we have $f^{(r,v)}(bb', n) = f^{(r,v)}(b'b, n)$. It remains to show that

$$(1.5.2) \quad f^{(r,v)}(b, n) = f^{(r,v)}(b \sigma_n^{\pm 1}, n+1).$$

Let $f_n: CB_n \rightarrow C$ be a C -linear function defined by $f_n(b) = f(b, n)$ for $b \in B_n$. For $v \in A(f)^\wedge$, let η_v be an element of CB_r such that $\rho_v(\eta_v) = \text{id}$ and $\rho_{v'}(\eta_v) = 0$ for $v \neq v' \in A_r(f)^\wedge$. Then $p_r(\eta_v)$ is contained in the center of $A_r(f)$, $p_r(\eta_v)^2 = p_r(\eta_v)$, and $p_r(\eta_v)p_r(\eta_{v'}) = 0$ if $v \neq v'$. Since $\rho_\mu(t_1(\eta_v)t_2(\eta_v)\dots t_n(\eta_v))$ is a

projection from V_μ to the $\rho_V^{\otimes n}$ -isotypic subspace $V_{\mu, \nu, \dots, \nu}$ of V_μ , we have $\rho_\mu(\iota_1(\eta_V)\iota_2(\eta_V)\dots\iota_n(\eta_V)\phi_n^{(r)}(b)) = \rho_{\mu, \nu}(\phi_n^{(r)}(b))$. Hence by (1.4.9) and Lemma 1.4.11, we get

$$(1.5.3) \quad \omega_{\mu, \nu}(b) = \chi_V(1)^{-1} \chi_\mu(\iota_1(\eta_V)\iota_2(\eta_V)\dots\iota_n(\eta_V)\phi_n^{(r)}(b))$$

for $\mu \in A_{rn}(f)^\wedge$ and $\nu \in A_r(f)^\wedge$.

This formula implies that

$$f^{(r, \nu)}(b\sigma_n^{\pm 1}, n+1) = \chi_V(1)^{-1} f_{rn+r}(\iota_1(\eta_V)\dots\iota_n(\eta_V)\iota_{n+1}(\eta_V)\phi_{n+1}^{(r)}(b\sigma_n^{\pm 1})) .$$

But we know, from Lemma 1.4.3, that $\iota_{n+1}(\eta_V)\phi_n^{(r)}(b\sigma_n^{\pm 1}) = \phi_{n+1}^{(r)}(b\sigma_n^{\pm 1})\iota_n(\eta_V)$ and so we have

$$\begin{aligned} f^{(r, \nu)}(b\sigma_n^{\pm 1}, n+1) &= \chi_V(1)^{-1} f_{rn+r}(\iota_1(\eta_V)\dots\iota_n(\eta_V)\phi_{n+1}^{(r)}(b\sigma_n^{\pm 1})\iota_n(\eta_V)) \\ &= \chi_V(1)^{-1} f_{rn+r}(\iota_n(\eta_V)\iota_1(\eta_V)\dots\iota_n(\eta_V)\phi_{n+1}^{(r)}(b\sigma_n^{\pm 1})) \\ &= \chi_V(1)^{-1} f_{rn+r}(\iota_1(\eta_V)\dots\iota_{n-1}(\eta_V)\iota_n(\eta_V)^2\phi_{n+1}^{(r)}(b\sigma_n^{\pm 1})) . \\ &= \chi_V(1)^{-1} f_{rn+r}(\iota_1(\eta_V)\dots\iota_{n-1}(\eta_V)\iota_n(\eta_V)\phi_{n+1}^{(r)}(b\sigma_n^{\pm 1})) . \end{aligned}$$

In the last step of the above calculation, we use $p_r(\eta_V)^2 = p_r(\eta_V)$.

Since $\phi_n^{(r)}(\sigma_n^{\pm 1}) = (\sigma_{rn}^{(r)})^{\pm 1}$, Lemma 1.2.4 implies that the last term of the above is equal to $\chi_V(1)^{-1} f_{rn+r}(\iota_1(\eta_V)\dots\iota_{n-1}(\eta_V)\iota_n(\eta_V)\phi_n^{(r)}(b))$, which is equal to $f^{(r, \nu)}(b, n)$ by (1.5.3). Hence we have (1.5.2). \square

1.6. Invariants of cable links. Let $\iota_i: B_r \rightarrow B_{rn}$ ($1 \leq i \leq n$) be the group homomorphism defined in Section 1.4.

Proposition 1.6.1. Let $b' \in B_r$ and \sim denote the Markov equivalence relation (Definition 1.1.2). Then we have the following:

- (a) For $b_1, b_2 \in B_n$ such that the closure of $b_1 b_2$ is a knot,
 $(\iota_1(b') \phi_n^{(r)}(b_1 b_2), rn) \sim (\iota_1(b') \phi_n^{(r)}(b_2 b_1), rn),$
- (b) For $b \in B_n$, $(\iota_1(b') \phi_n^{(r)}(b), rn) \sim (\iota_1(b') \phi_{n+1}^{(r)}(b \sigma_n^{\pm 1}), rn+r).$

Proof. Lemma 1.2.4 shows the part (b). By using Definition 1.1.2 (ii) and Lemma 1.4.3, we have

$$\begin{aligned} (\iota_1(b') \phi_n^{(r)}(b_1 b_2), rn) &\sim (\phi_n^{(r)}(b_1 b_2) \iota_1(b'), rn) \\ &= (\iota_{b_1 b_2(1)}^{(b') \phi_n^{(r)}(b_1 b_2)}, rn) \sim \dots \\ &\sim (\iota_{(b_1 b_2)^k(1)}^{(b') \phi_n^{(r)}(b_1 b_2)}, rn) \quad (k=1, 2, \dots) \\ &\sim (\iota_{b_2(b_1 b_2)^k(1)}^{(b') \phi_n^{(r)}(b_2 b_1)}, rn). \end{aligned}$$

Since the closure of $b_1 b_2$ is a knot, we have $\{(b_1 b_2)^k(1) \mid k=0, 1, \dots, n-1\} = \{1, \dots, n\}$ and so there is k_0 with $(b_1 b_2)^{k_0}(1) = b_2^{-1}(1)$. Hence we have $(\iota_{b_2(b_1 b_2)^{k_0}(1)}^{(b') \phi_n^{(r)}(b_2 b_1)}, rn) = (\iota_1(b') \phi_n^{(r)}(b_2 b_1), rn)$. This proves the part (a). \square

The above proposition and Theorem 1.1.3 yield the following.

Corollary 1.6.2. Let $b' \in B_r$ and $(b_1, n_1), (b_2, n_2)$ be two braids such that the closures of b_1 and b_2 are knots. Then the closures of $(\iota_1(b')\phi_{n_1}^{(r)}(b_1), rn_1)$ and $(\iota_1(b')\phi_{n_2}^{(r)}(b_2), rn_2)$ are equivalent if $(b_1, n_1)^\wedge$ and $(b_2, n_2)^\wedge$ are equivalent.

Definition 1.6.3 (cable links). For a braid (b, n) and $b' \in B_r$, we call $(\iota_1(b')\phi_n^{(r)}(b), rn)^\wedge$ the (r-strand) cable link of $(b, n)^\wedge$ associated with b' . For a function f on B , let $f_{b'}^{(r)}(b, n) = f(\iota_1(b')\phi_n^{(r)}(b), rn)$. For $b' \in CB_r$, let $f_{b'}^{(r)}(b, n) = f(\iota_1(b')\phi_n^{(r)}(b), rn)$.

The r-strand cable link is well-defined by Corollary 1.6.2, and so $X_{b'}^{(r)}$ is an invariant of link isotopy types for a link invariant X and $b' \in CB_r$.

Theorem 1.6.4. Let $b' \in CB_r$. For a braid $b \in B_n$ whose closure is a knot and a C -valued function f on B of trace type, $f_{b'}^{(r)}$ satisfies

$$f_{b'}^{(r)}(b, n) = \sum_{\nu \in A_r(f)^\wedge} \chi_\nu(b') f^{(r, \nu)}(b, n) .$$

Proof. Since $f_{b'}^{(r)}(b, n) = \sum_{\mu \in A_{rn}(f)^\wedge} \chi_\mu(\iota_1(b')\phi_n^{(r)}(b))$, we get the

statement of the theorem by (1.4.9) and Lemma 1.4.11. \square

2. The parallel version of link invariants, II (the case of general links). In this section, we give a generalization of Theorems 1.4.10 and 1.6.4 for braids whose closures are links.

2.1. The characters associated with the parallel version. Fix a C -valued function f on B of trace type and fix an element $b_0 \in B_n$. Let $B_n(b_0) = \{b \in B_n \mid \text{every } \langle \theta(b_0) \rangle\text{-orbit of } \Omega \text{ is contained in a single } \langle \theta(b) \rangle\text{-orbit of } \Omega\}$, where $\Omega = \{1, \dots, n\}$. We use the notations in Sections 1.3 and 1.4. Lemma 1.4.3 implies that the subgroup $\iota(B_r^n) \phi_n^{(r)}(B_n(b_0))$ of B_{rn} is isomorphic to the wreath product $B_r^n \rtimes B_n(b_0)$ with respect to $\theta: B_n \rightarrow S_n$. For $v = (v_1, \dots, v_n)$ ($v_i \in A_r(f)^\wedge$), let $\rho_v = \rho_{v_1} \otimes \dots \otimes \rho_{v_n}$ be the representation of B_r^n . For $\mu \in A_{rn}(f)^\wedge$, let $V_{\mu, v}$ be the ρ_v -isotypic subspace of V_μ as a CB_{rn} -module. Let $\delta(j) = \min \langle \theta(b_0) \rangle \cdot j$ for $j \in \Omega$. If $v_j = v_{\delta(j)}$ for $1 \leq j \leq n$, then by Lemma 1.4.3, $V_{\mu, v}$ is invariant relative to the action of $B_r^n \rtimes B_n(b_0)$. In this case, let $\rho_{\mu, v}$ denote the representation of $\iota(B_{rn}) \phi_n^{(r)}(B_n(b_0))$ obtained by restricting ρ_μ on $V_{\mu, v}$ and $\chi_{\mu, v}$ its character. Then we have the following.

Proposition 2.1.1. Let k be the number of $\langle \theta(b_0) \rangle$ -orbits of Ω and $\{\delta(j) \mid j \in \Omega\} = \{m_1, \dots, m_k\}$. Then we have

$$\chi_\mu(\phi_n^{(r)}(b_0)) = \sum_{v_{m_1} \in A_r(f)^\wedge} \dots \sum_{v_{m_k} \in A_r(f)^\wedge} \chi_{\mu, (v_{\delta(1)}, \dots, v_{\delta(n)})}(\phi_n^{(r)}(b_0)).$$

Proof. The proof of Proposition 1.4.8 shows that $\chi_\mu(\phi_n^{(r)}(b_0))$ is equal to the sum of the diagonal elements of $\rho_\mu(\phi_n^{(r)}(b_0))$

corresponding to the subspaces $V_{\mu, (v_1, \dots, v_n)}$ such that $V_{\mu, (v_1, \dots, v_n)} = V_{\mu, (v_{\theta(b_0)^{-1}(1)}, \dots, v_{\theta(b_0)^{-1}(n)})}$. If $V_{\mu, (v_1, \dots, v_n)} = V_{\mu, (v_{\theta(b_0)^{-1}(1)}, \dots, v_{\theta(b_0)^{-1}(n)})}$, then we have $v_j = v_{\delta(j)}$ and the sum of diagonal elements of $\rho_{\mu}(\phi_n^{(r)}(b_0))$ corresponding to the subspace $V_{\mu, (v_1, \dots, v_n)}$ is equal to $\chi_{\mu, (v_{\delta(1)}, \dots, v_{\delta(n)})}(\phi_n^{(r)}(b_0))$. Hence we get the statement of the proposition. \square

Let $v = (v_1, \dots, v_n) \in (A_r(f)^\wedge)^n$ with $v_j = v_{\delta(j)}$. Since $\iota(B_r^n) \phi_n^{(r)}(B_n(b_0))$ is isomorphic to $B_r^n \times B_n(b_0)$, we see, from Proposition 1.3.4, that there is a representation $\pi_{\mu, v}$ of B_n such that

$$(2.1.2) \quad \rho_{\mu, v} \cong \rho_v \otimes \pi_{\mu, v}$$

where ρ_v is the representation of $\iota(B_r^n) \phi_n^{(r)}(B_n(b_0))$ coming from the representation ρ_v of B_r^n as in Proposition 1.3.4. Let $\chi_v, \omega_{\mu, v}$ be the characters of $\rho_v, \pi_{\mu, v}$ respectively. Now we can state a generalized version of Theorem 1.4.10.

Theorem 2.1.3. (i) For $\mu \in A_{rn}(f)^\wedge$,

$$\chi_{\mu}(\phi_n^{(r)}(b_0)) = \sum_{v_{m_1} \in A_r(f)^\wedge} \dots \sum_{v_{m_k} \in A_r(f)^\wedge} \left(\prod_{j=1}^k \chi_{v_{m_j}}(1) \right) \omega_{\mu, (v_{\delta(1)}, \dots, v_{\delta(n)})}(b_0).$$

$$(ii) \quad f^{(r)}(b_0)$$

$$= \sum_{\mu \in A_{rn}(f)} \sum_{v_{m_1} \in A_r(f)} \dots \sum_{v_{m_k} \in A_r(f)} a_\mu(f) \left(\prod_{j=1}^k \chi_{v_{m_j}}(1) \right) \omega_{\mu, (v_{\delta(1)}, \dots, v_{\delta(n)})}^{(b_0)}.$$

Proof. Proposition 2.1.1 and (2.1.2) yield that

$$\chi_\mu(\phi_n^{(r)}(b_0)) = \sum_{v_{m_1} \in A_r(f)} \dots \sum_{v_{m_k} \in A_r(f)} \chi_{\mu, (v_{\delta(1)}, \dots, v_{\delta(n)})}^{(b_0)}$$

$$= \sum_{v_{m_1} \in A_r(f)} \dots \sum_{v_{m_k} \in A_r(f)} (\chi_{v^-}(\phi_n^{(r)}(b_0))) \omega_{\mu, (v_{\delta(1)}, \dots, v_{\delta(n)})}^{(b_0)}.$$

Hence the first formula is an immediate consequence of following Lemma 2.1.4. The second one is obtained from (i) and (1.4.1). \square

Lemma 2.1.4. We have

$$\chi_{v^-}(b_0) = \prod_{j=1}^k \chi_{v_{m_j}}(1).$$

Proof. By using (1.3.3), we have

$$\chi_{v^-}(\phi_n^{(r)}(b_0))$$

$$= \sum_{\alpha_1, \beta_1, \dots, \alpha_n, \beta_n} \delta_{\alpha_1 \beta_1} \dots \delta_{\alpha_n \beta_n} (\rho_{v_1}(1)_{\alpha_1 \beta_{\theta(b_0)^{-1}(1)}} \rho_{v_2}(1)_{\alpha_2 \beta_{\theta(b_0)^{-1}(2)}} \dots \rho_{v_n}(1)_{\alpha_n \beta_{\theta(b_0)^{-1}(n)}}).$$

Let $|S|$ denote the cardinality of a set S . Each term of the above summation is zero unless

$$\alpha_{m_j} = \beta_{\theta(b_0)^{-1}(m_j)} = \alpha_{\theta(b_0)^{-1}(m_j)} = \dots = \alpha_{\theta(b_0)^{-|\psi^{-1}(j)|+1}(m_j)} = \beta_{m_j} \quad (1 \leq j \leq k).$$

But the above equalities implies that $\alpha_i = \beta_i = \alpha_j = \beta_j$ for i and j such that $\langle \theta(b_0) \rangle \cdot i = \langle \theta(b_0) \rangle \cdot j$. Hence we have

$$\chi_{\nu}^{-}(b_0) = \prod_{j=1}^k \left(\sum_{\alpha_{m_j}} \rho_{\nu_j}(1) \alpha_{m_j} \right) = \prod_{j=1}^k \chi_{\nu_j}(1).$$

This proves Lemma 2.1.4. \square

2.2. Further generalizations. In this section, we state a generalized version of Theorem 1.6.4 for cable links of multi-component links. We omit proofs of the results in this section, which are analogous to those of corresponding facts in Section 1.

Let K be a k -component link. A bijection Ψ from the set of connected components of K to $\{1, 2, \dots, k\}$ is called a marking of K and the pair (K, Ψ) is called a (k -component) marked link. The connected component C of K with $\Psi(C) = i$ is called the i -th component of K . Let $R = (r_1, r_2, \dots, r_k) \in \mathbb{N}^k$. Let $(K, \Psi)^{(R)}$ denote the link diagram obtained by replacing each crossing point of a link diagram of K as in Figure 6. The link type of $(K, \Psi)^{(R)}$ is not depend on the choice of link diagrams of K . We call $(K, \Psi)^{(R)}$ the R -parallel version of (K, Ψ) . For a link invariant X , let $X^{(R)}(K, \Psi) = X((K, \Psi)^{(R)})$. Then $X^{(R)}$ is an invariant of k -component marked links and is called the R -parallel version of X . We can show

a generalized version of Theorem 2.1.3 (ii) for $X^{(R)}$. We omit the details.

Figure 6.

Let (K, Ψ) be a k -component marked link, $R = (r_1, r_2, \dots, r_k) \in \mathbb{N}^k$ and $b = (b_1, b_2, \dots, b_k) \in B_{r_1} \times \dots \times B_{r_k}$. Let $(K, \Psi)_b$ denote the link obtained by inserting the braid b_i ($1 \leq i \leq k$) to the bunch of the components of $(K, \Psi)^{(R)}$ corresponding to the component of K sent to i by Ψ as in Figure 7. We call $(K, \Psi)_b$ the cable link of (K, Ψ) associated with b . For a link invariant X , let $X_b(K, \Psi) = X((K, \Psi)_b)$. Then X_b is an invariant of k -component marked links.

Figure 7.

Then we have:

Theorem 2.2.1. Let X be a link invariant of trace type, $R = (r_1, r_2, \dots, r_k) \in \mathbb{N}^k$ and $b = (b_1, b_2, \dots, b_k) \in B_{r_1} \times \dots \times B_{r_k}$. Then there are invariants $X^{(R, v)}$ of k -component marked links parametrized by $v = (v_1, v_2, \dots, v_k) \in A_{r_1}(X)^\wedge \times \dots \times A_{r_k}(X)^\wedge$ which satisfy the following. For a k -component marked link (K, Ψ) ,

$$X_b(K, \Psi) = \sum_{(v_1, \dots, v_k) \in A_{r_1}(X)^\wedge \times \dots \times A_{r_k}(X)^\wedge} \left(\prod_{j=1}^k \chi_{v_j}(b_j) \right) X^{(R, v)}(K, \Psi).$$

This theorem is a generalization of Theorems 1.5.1 and 1.6.4.

3. The r -parallel version of the two-variable Jones polynomial.

In this section we review representation theory of Iwahori algebras and the two-variable Jones polynomial. At the end of this section, we shall construct representations of B_3 associated with the two-parallel version of the two-variable Jones polynomial. Fix non-zero complex numbers α and s such that s is not equal to any roots of unity. Let $q^{k/2} = s^k$ for an integer k .

Definition 3.1 ([3], p.55, ex.23; [18]). Let $H_n(q)$ be a \mathbb{C} -algebra with a unit defined by the following relations:

$$(3.2) \ H_n(q) = \langle T_1, T_2, \dots, T_{n-1} \mid \begin{aligned} T_i^2 + (1-q)T_i - q &= 0 \quad (1 \leq i \leq n-1), \\ T_i T_{i+1} T_i &= T_{i+1} T_i T_{i+1} \quad (1 \leq i \leq n-2), \\ T_i T_j &= T_j T_i \quad (1 \leq i < j-1 \leq n-2) \end{aligned} \rangle.$$

We call $H_n(q)$ the Iwahori's Hecke algebra of type A_{n-1} . For simplicity, we denote $H_n(q)$ by H_n if there is no fear of confusion.

It is known that H_n is semisimple (see, e.g. [11]) and isomorphic to the group algebra $\mathbb{C}S_n$ of the symmetric group S_n of degree n .

Definition 3.3. Let $\Lambda(n)$ be the set of partitions of n , i.e.

$$\Lambda(n) = \{(\lambda_1, \lambda_2, \dots) \mid \sum_i \lambda_i = n, \lambda_i \in \mathbb{N} \cup \{0\}, \lambda_i \geq \lambda_{i+1} \ (i \in \mathbb{N})\}.$$

For $\lambda = (\lambda_1, \lambda_2, \dots) \in \Lambda(n)$, let $\lambda_i^* = \max\{j \mid \lambda_j \geq i\}$ if $i \leq \lambda_1$ and $\lambda_i^* = 0$ if $i > \lambda_1$. We call $\lambda^* = (\lambda_1^*, \lambda_2^*, \dots)$ the dual partition of λ .

As is well-known, the irreducible representations of S_n are parametrized by $\Lambda(n)$. Hence $\Lambda(n)$ parametrizes the irreducible

representations of H_n , too. Let $(\rho_\lambda, V_\lambda)$ be the representation of H_n parametrized by a partition $\lambda \in \Lambda(n)$ and χ_λ its character. For each $\lambda \in \Lambda(n)$, we know [12] the representation matrices of $\rho_\lambda(T_i)$ ($1 \leq i \leq n-1$) with respect to a basis parametrized by the standard tableaux corresponding to the partition λ .

Remark 3.4. Fix $\lambda \in \Lambda(n)$, and let \mathcal{S}_λ be the set of standard tableaux corresponding to the partition λ . For $S \in \mathcal{S}_\lambda$, S^* denote the transpose of S , which is a standard tableau corresponding to λ^* . Let $\{e_S \mid S \in \mathcal{S}_\lambda\}$ and $\{e_{S^*} \mid S \in \mathcal{S}_\lambda\}$ be the basis of V_λ and V_{λ^*} given in [12] respectively. Let $\eta: V_\lambda \rightarrow V_{\lambda^*}$ be the linear isomorphism defined by $\eta(e_S) = e_{S^*}$ ($S \in \mathcal{S}_\lambda$). Then there is a diagonal matrix D with respect to the basis $\{e_S \mid S \in \mathcal{S}_\lambda\}$ such that

$$\rho_\lambda(T_i)(q) = D^{-1} \eta^{-1}(-q \rho_{\lambda^*}(T_i)(q^{-1})) \eta D.$$

By the defining relations of B_n and H_n , there is an algebra homomorphism $p_n^{(\alpha)}: CB_n \rightarrow H_n$ defined by $p_n^{(\alpha)}(\sigma_i) = \alpha T_i$.

Theorem 3.5 ([7]). Let $\ell = (-q)^{1/2} \alpha$, $m = (-1)^{1/2} (q^{-1/2} - q^{1/2})$ and $P(\cdot)(\ell, m)$ be the two-variable Jones polynomial. Then, for $b \in B_n$, we have

$$P(b) = \sum_{\lambda \in \Lambda(n)} a_\lambda(P) \chi_\lambda(p_n^{(\alpha)}(b)),$$

where the coefficients $a_\lambda(P) \in \mathbb{C}$ ($\lambda \in \Lambda(n)$) are given in [10] or [15].

The coefficients $a_\lambda(P)$ ($\lambda \in \Lambda(n)$) satisfies

$$(3.6) \quad a_\lambda(P)(\alpha, q) = a_{\lambda^*}(P)(-\alpha q, q^{-1}).$$

Let K be a link. For a positive integer r and $v \in \Lambda(r)$, let $p^{(r,v)}$ be the invariant parametrized by (r, ρ_v) as in Section 1.5. Then Remark 3.4 and (3.6) implies the following.

$$(3.7) \quad p^{(r,v)}(K)(\alpha, q) = p^{(r,v^*)}(K)(-\alpha q, q^{-1}).$$

Let I be a subset of $\{1, \dots, n-1\}$, H_I the subalgebra of H_n generated by $\{T_i \mid i \in I\}$, and S_I the subgroup of S_n generated by $\{(i \ i+1) \mid i \in I\}$. Let ρ'_λ be the representation of S_n parametrized by $\lambda \in \Lambda(n)$. Let $\{\lambda_1, \lambda_1 + \lambda_2, \dots, \lambda_1 + \lambda_2 + \dots + \lambda_p\} = \{1, 2, \dots, n\} \setminus I$ and $\Lambda_I = \Lambda(\lambda_1) \times \Lambda(\lambda_2) \times \dots \times \Lambda(\lambda_p)$. Then the irreducible representations of H_I and S_I are parametrized by Λ_I . The restriction $\rho_\lambda|_{H_I}$ and $\rho'_\lambda|_{S_I}$ are sums of irreducible representations of H_I and S_I respectively,

e.g. $\rho_\lambda|_{H_I} = \bigoplus_{\mu \in \Lambda_I} m_{\lambda, \mu} \rho_\mu$ and $\rho'_\lambda|_{S_I} = \bigoplus_{\mu \in \Lambda_I} m'_{\lambda, \mu} \rho'_\mu$, where ρ_μ and ρ'_μ

are representation of H_I and S_I parametrized by $\mu \in \Lambda_I$.

Proposition 3.8. Let $\mu_0 \in \Lambda_I$ such that the corresponding representation ρ'_{μ_0} of S_I is trivial. Then the above multiplicities m_{λ, μ_0} and m'_{λ, μ_0} are equal.

Proof. The construction of each irreducible representations of H_n and H_I in [12] satisfies the following: The entries of the matrices of the generators T_i are all rational functions of the parameter q with poles at roots of unity. On the other hand, the above proposition is proved for infinitely many integer values of q by using [5]

Theorem 7.2. But we know that CS_I and H_I are semisimple if q is not equal to any roots of unity. Hence m_{λ, μ_0} and m'_{λ, μ_0} are equal if q is not equal to any roots of unity. \square

Remark 3.9. Because of the above proposition, we can calculate m_{λ, μ_0} by the Littlewood-Richardson rule ([13], 2.8.13).

Let ρ_λ be the representation of H_{rn} parametrized by $\lambda \in \Lambda(rn)$ and ρ_ν that of H_r parametrized by $\nu \in \Lambda(r)$. Let $\pi_{\lambda, \nu}$ be the representation of B_{rn} parametrized by ρ_λ and ρ_ν as in Section 1.4. In Table 2, the representation matrices of $\pi_{\lambda, \nu}$ are given in the case of $n=3$, $r=2$ and $\nu=(2)$. By using Theorems 1.4.10, 1.5.1, 3.5 and (3.7), we may calculate $P^{(2,(2))}$, $p^{(2,(11))}$ and $P^{(2)}$ for knots equivalent to the closures of 3-braids. To obtain these matrices, we use the representation matrices of the generators of H_6 given by W -graphs introduced in [18]. The W -graphs corresponding to the irreducible representations of H_6 are actually constructed by Naruse and Gyoja (Figure 8).

Figure 8.

Table 2.

4. The r -parallel version of the one-variable Jones polynomial.

In this section we discuss the r -parallel version $V^{(r)}$ of the one-variable Jones polynomial V in detail. We give a formula for the one-variable Jones polynomials of satellite links (Theorem 4.3.2). Let $V^{(r,V)}$ denote the invariant associated with $V \in A_r(V)^\wedge$. The representation matrices of $\pi_{\mu, V} \in B_3^\wedge$ ($\mu \in A_{3r}(V)^\wedge$, $V \in A_r(V)^\wedge$) associated with $V^{(r,V)}$ are given explicitly (Theorem 4.4.1). By using these matrices we can easily compute $V^{(r)}(\hat{b})$ for a knot \hat{b} which is the closure of a 3-braid b . The cases $r=2$ and $r=3$ are discussed closely in (4.4.3)-(4.4.10).

4.1. The Jones algebra. In this section we review the definition of the Jones algebra J_n , which is the associated algebra $A_n(V)$ (Definition 1.1.6) of the one-variable Jones polynomial V . We also review the construction of the irreducible representations of J_n [15] in terms of rectangular diagrams for our later convenience. Fix a non-zero complex number s which is not equal to a root of unity. Let $t^{k/4} = s^k$ for an integer k .

Definition 4.1.1. The Jones algebra $J_n = J_n(t)$ is a \mathbb{C} -algebra with 1 defined by the following.

$$\begin{aligned}
 J_n(t) = \langle e_1, e_2, \dots, e_{n-1} \mid & e_i e_i = -(t^{1/2} + t^{-1/2}) e_i \quad (1 \leq i \leq n-1), \\
 & e_i e_{i+1} e_i = e_i, \quad e_{i+1} e_i e_{i+1} = e_{i+1} \quad (1 \leq i \leq n-2), \\
 & e_i e_j = e_j e_i \quad (1 \leq i < j-1 < n-1) \rangle.
 \end{aligned}$$

For simplicity, we denote $J_n(t)$ by J_n if there is no fear of confusion.

Since $-(t^{1/2} + t^{-1/2})^{-1}e_i$ ($1 \leq i \leq n-1$) is an idempotent of J_n , we have

Proposition 4.1.2. For $x \in J_n$, $e_i x = cx$ ($c \in \mathbb{C} \setminus \{0\}$) iff $x \in e_i J_n$.
In this case, c is always equal to $-(t^{1/2} + t^{-1/2})$.

Definition 4.1.3. Let s be a positive real number and $R = [0, s] \times [0, 1]$. Let n be a positive integer, $R \ni \alpha_i = (0, i/(n+1)), \beta_i = (s, i/(n+1))$ ($1 \leq i \leq n$) and $\gamma_1, \dots, \gamma_n$ curves contained in R . Then $(R, \{\gamma_1, \dots, \gamma_n\})$ is called an (unoriented) rectangular diagram of degree n if it satisfies the following.

- (i) Any of the points $\alpha_1, \dots, \alpha_n, \beta_1, \dots, \beta_n$ is one of the end points of the curves $\gamma_1, \dots, \gamma_n$.
- (ii) There is no triple crossing point of the curves.
- (iii) Every curve has a marking at the each crossing point indicating whether the curve under consideration is the over path or the under path at the crossing.
- (iv) The intersection of the curves $\gamma_1, \dots, \gamma_n$ and the boundary of R is equal to $\{\alpha_1, \dots, \alpha_n, \beta_1, \dots, \beta_n\}$.

A diagram $(R, \{\gamma_1, \dots, \gamma_n\})$ is called a rectangular diagram without crossing points of degree n if the curves $\gamma_1, \dots, \gamma_n$ do not intersect themselves. If orientations are given to all the curves in R , then R is called an oriented rectangular diagram of degree n .

We call $\alpha_1, \dots, \alpha_n$ (respectively β_1, \dots, β_n) the points at the top (respectively bottom) of R . Two rectangular diagrams $([0, s] \times [0, 1], \{\gamma_1, \dots, \gamma_n\})$ and $([0, s'] \times [0, 1], \{\gamma'_1, \dots, \gamma'_n\})$ of degree n are called equivalent if there is a homeomorphism $f: [0, s] \times [0, 1] \rightarrow [0, s'] \times [0, 1]$ such that $f((0, t)) = (0, t)$, $f((s, t)) = (s', t)$ ($t \in [0, 1]$) and $f(\gamma_i) = \gamma'_i$ ($1 \leq i \leq n$).

We define algebras D_n ($n \in \mathbb{N}$) over C . Let E_n' denote the set of the equivalence classes of rectangular diagrams without crossing points of degree n . With the convention $\#E_0' = 1$, the number $\#E_n'$ of elements of E_n' ($n \in \mathbb{N}$) satisfy the recursive relations $\#E_n' =$

$\sum_{k=0}^{n-1} \#E_k' \#E_{n-k-1}'$. Hence $\#E_n'$ is equal to the Catalan number

$\binom{2n}{n} / (n+1)$ ([20], §2.3.4.4). As a C -vector space, we put $D_n =$

$\bigoplus_{e \in E_n'} Ce$; in particular,

$$(4.1.4) \quad \dim_C D_n = \binom{2n}{n} / (n+1).$$

To define the multiplication in D_n , it is enough to define the product ab for two equivalence classes a and b of rectangular diagrams $([0, s] \times [0, 1], \{\gamma_1, \dots, \gamma_n\})$ and $([0, s'] \times [0, 1], \{\gamma'_1, \dots, \gamma'_n\})$. This is done similarly as with the case of braids by the following rule.

- (a) Let $R = [0, s+s'] \times [0, 1]$. Let $g: [0, s] \times [0, 1] \rightarrow R$ and $g': [0, s'] \times [0, 1] \rightarrow R$ be the mappings defined by $g((x, y)) = (x, y)$ and $g'((x, y)) = (x+s, y)$ respectively.

(b) Let $(\bigcup_{i=1}^m \delta_i) \cup (\bigcup_{i=1}^n \gamma_i)$ be the decomposition of $(\bigcup_{i=1}^n g(\gamma_i)) \cup$

$(\bigcup_{i=1}^n g'(\gamma_i'))$ into connected components, where δ_i ($1 \leq i \leq m$)

are closed curves and γ_i ($1 \leq i \leq n$) are curves with end points.

(c) Let d be the equivalence class of the rectangular diagram $(R, \{\gamma_1, \dots, \gamma_n\})$. Then $ab = (-t^{1/2} - t^{-1/2})^m d$.

Let e_i' ($1 \leq i \leq n-1$) denote the rectangular diagrams given in Figure 9.

Then we have

Figure 9

$$e_i'^2 = (-t^{1/2} - t^{-1/2}) e_i' \quad (1 \leq i \leq n-1),$$

(4.1.5)

$$e_i' e_{i+1}' e_i' = e_i', \quad e_{i+1}' e_i' e_{i+1}' = e_{i+1}' \quad (1 \leq i \leq n-2).$$

Hence there is a homomorphism η from J_n to D_n sending e_i to e_i' . But, by [15] and (4.1.4), we have

$$\dim_{\mathbb{C}} J_n = \binom{2n}{n} / (n+1) = \dim_{\mathbb{C}} D_n.$$

Hence η is an isomorphism. Let $E_n = \eta^{-1}(E_n')$. Then E_n is a basis of J_n . The definition of the multiplication in D_n implies that, for e_i' and $x \in E_n'$, $e_i' x$ is a non-zero scalar multiple of an element of E_n' . Hence $e_i J_n$ is spanned by a subset of E_n . Combining this observation with Proposition 4.1.2, we get the following.

Proposition 4.1.6. The subspace $e_i J_n$ of J_n is spanned by

$E_n^{(i)} = \{\eta^{-1}(x) \mid x \in E_n', \text{ the } i\text{-th and } (i+1)\text{-th points at the top of } x \text{ are connected by a curve of } x\}$.

For $y \in E_n'$, let $T_D(y)$ denote the number of strings of y connecting two points at the top of y . For example,

$$(4.1.7) \quad T_D(\eta(e_1 e_3 \dots e_{2j-1})) = j.$$

Let $E_{n,i} = \{\eta^{-1}(y) \mid y \in E_n', T_D(y) \geq i\}$ and $J_{n,i}$ the two-sided ideal of J_n generated by the elements of $E_{n,i}$. Since $T_D(yy') \geq \max(T_D(y), T_D(y'))$ for $y, y' \in E_n'$, $J_{n,i}$ is equal to the \mathbb{C} -linear span of $E_{n,i}$ in J_n . For $x \in J_n$, we have

$$(4.1.8) \quad e_{i(1)} e_{i(2)} \dots e_{i(k)} x \in J_{n,k} \quad (i(j) < i(j+1) - 1 \text{ for } 1 \leq j < k).$$

Let $J_{n,i} = J_{n,i} / J_{n,i+1}$. Since J_n is known to be semisimple, the canonical projection $J_{n,i} \rightarrow J_{n,i}$ splits. Hence $J_{n,i}$ can be regarded as a two-sided ideal of J_n .

Proposition 4.1.9. The two-sided ideals $J_{n,i}$ ($0 \leq i \leq [n/2]$) of J_n

are simple algebras and $J_n \cong \bigoplus_{i=0}^{[n/2]} J_{n,i}$.

proof. Let $e(1,2i-1) = e_1 e_3 \dots e_{2i-1}$ ($0 \leq i \leq [n/2]$). Since $e(1,2i-1) \in J_{n,i}$ and $e(1,2i-1) \notin J_{n,i+1}$, $J_{n,i} \neq \{0\}$ for $0 \leq i \leq [n/2]$. We also know ([15], §11) that J_n is a direct sum of $[n/2]+1$ two-sided ideals which are simple algebras. Hence, by using Jordan-Hölder's Theorem, we conclude that the two-sided ideals $J_{n,i}$ ($0 \leq i \leq [n/2]$) are non-trivial simple algebras. \square

Since J_n is a semisimple algebra over C , the two-sided ideals $J_{n,i}$ of J_n ($0 \leq i \leq [n/2]$) are isomorphic to the full matrix algebras over C . Let $\rho_{n,i}: J_n \rightarrow J_{n,i}$ denote the associated irreducible representations of J_n , and $\chi_{n,i}$ their characters.

Let $p_n, p'_n: CB_n \rightarrow J_n(t)$ be the algebra homomorphisms defined by $\sigma_i \rightarrow -t^{1/2} - t e_i$ and $\sigma_i \rightarrow t^{-1/4} + t^{1/4} e_i$ respectively. Then the Jones polynomial V and the bracket polynomial $\langle \cdot \rangle$ for the closure of an n -braid b are written as linear combinations of these characters, i.e.

$$V(b^\wedge) = \sum_{i=0}^{[r/2]} a_{n,i}(V) \chi_{n,i}(p_n(b)),$$

(4.1.10)

$$\langle b^\wedge \rangle = \sum_{i=0}^{[r/2]} a_{n,i}(V) \chi_{n,i}(p'_n(b)),$$

The coefficients $a_{n,i}(V)$ are given by

$$(4.1.11) \quad a_{n,i}(V) = (-1)^{n+1} (t^{n/2+1/2-i} - t^{-n/2-1/2+i}) / (t - t^{-1}),$$

(see [10], [15], [16]).

Note that none of the coefficients $a_{n,i}(V)$ are equal to zero because t is not a root of unity.

Remark 4.1.12. Let $\varphi_n : H_n(t) \rightarrow J_n(t)$ be the algebra homomorphism defined by $\varphi_n(T_i) = -1 - t^{1/2} e_i$. The compositions $\rho_{n,i} \circ \varphi_n$ for $0 \leq i \leq [n/2]$ give irreducible representations of $H_n(t)$ parametrized by the partitions $(\underbrace{2 \ 2 \ \dots \ 2}_{i\text{-times}} \ \underbrace{2 \ 1 \ 1 \ \dots \ 1}_{(n-2i)\text{-times}})$.

Definition 4.1.13. Let G_n denote the free semigroup generated by $1, f_i, \sigma_i, \sigma_i^{-1}$ ($1 \leq i \leq n-1$), $G = \{(g, n) \mid g \in G_n\}$ and for $(g, n) \in G$, let $d(g, n)$ denote the rectangular diagram (Definition 4.1.3) of (g, n) defined as in Figure 10.

Figure 10.

By the analogy with braids we use the term closure of a rectangular diagram $d(g, n)$, written $(g, n)^\wedge$, to mean the link formed by joining the n points at the top of $d(g, n)$ to those at the bottom without further crossings. Let $\psi_n : CG_n \rightarrow J_n$ denote the algebra homomorphism defined by

$$\psi_n(f_i) = e_i, \quad \psi_n(\sigma_i) = t^{-1/4} + t^{1/4} e_i, \quad \psi_n(\sigma_i^{-1}) = t^{1/4} + t^{-1/4} e_i.$$

By using the original definition of $\langle \cdot \rangle$ in [16], we can show that

$$(4.1.14) \quad \langle (g, n)^\wedge \rangle = \sum_{i=0}^{[r/2]} a_{n,i}(V) \chi_{n,i}(\psi_n(g)),$$

where the coefficients $a_{n,i}(V)$ are given by (4.1.11).

4.2. Relations among the invariants associated with the decomposition (1.5.1) of $V^{(r)}$. Let p_r be the homomorphism from CB_r to J_r defined just before (4.1.10). Let $v^{(r,i)}$ denote the invariant associated with the irreducible representation $\rho_{r,i} \circ p_r$ of B_r (see Sections 1.4 and 4.1). In this section, we give relations among $v^{(r,i)}$. In the following we use the conventions that $v^{(0)}(K) = v^{(0,0)}(K) = \langle |K| \rangle^{(0)} = \langle |K| \rangle^{(0,0)}(K) = (-t^{-1/2} - t^{1/2})^{-1}$ for any link diagram K .

Theorem 4.2.1. Let K be a knot. Then we have

$$v^{(r,i)}(K) = v^{(r-2k, i-k)}(K) \quad \text{for } r \geq 0, 0 \leq i \leq [r/2], 0 \leq k \leq i.$$

Remark 4.2.2. The same is also true in the case when K is a general link. We restrict our attention to the present case for simplicity.

Corollary 4.2.3. Let K be a knot. Then we have

$$(i) \quad v^{(r)}(K) = \sum_{i=0}^{[r/2]} \chi_{r,i}(1) v^{(r-2i,0)}(K) \quad \text{for } r \geq 0,$$

(ii) $v^{(r,0)}(K)$ is a linear combination of $v^{(s)}(K)$ ($s = r, r-2, \dots, r-2[r/2]$) with integer coefficients.

(iii) $(t^{1/2} + t^{-1/2}) v^{(r,j)}(K)$ is a Laurent polynomial in the parameter $t^{1/2}$.

Proof. The formula (i) is an immediate consequence of Theorems 1.4.10 and 4.2.1. Solving the formula (i) with respect to $v^{(s,0)}(K)$, we get

$$v^{(s,0)}(K) = \sum_{r=s, s-2, \dots} c_{s,r} v^{(r)}(K) \quad (c_{s,r} \in \mathbb{C}).$$

Since $\chi_{r,0}(1) = 1$, the coefficients $c_{s,r}$ ($r = s, s-2, \dots$) are all integers and so we get (ii). By (4.1.11), the coefficients $(t^{1/2} + t^{-1/2}) a_{rn,i}(V)$ are Laurent polynomials in $t^{1/2}$. We also know [12] that the characters $\chi_{rn,i}(p_{rn}(b))$ ($n \in \mathbb{N}$, $0 \leq i \leq [rn/2]$, $b \in B_{rn}$) are Laurent polynomials in $t^{1/2}$. Hence (ii) follows from (iii). \square

To prove Theorem 4.2.1, we need the bracket polynomial $\langle \cdot \rangle$ defined on G (see the last paragraph of Section 4.1). By (4.1.10), the bracket polynomial is of trace type. Applying Theorem 1.6.4 to $\langle \cdot \rangle$, we get the following.

Proposition 4.2.4. For $b' \in CB_r$ and a braid (b, n) we have

$$\langle (b, n) \rangle_{b'}^{(r)} = \sum_{i=0}^{[r/2]} \chi_{r,i}(p_r'(b')) \langle (b, n) \rangle^{(r,i)} \quad \text{for } r \geq 0.$$

Let $f_i' \in CB_{rn}$ such that $p_{rn}'(f_i') = e_i$ ($1 \leq i \leq rn-1$). Then we have the following:

Proposition 4.2.5. For $b \in B_n$, we have

$$\langle (b, n) \rangle_{f_1' f_3' \dots f_{2j-1}'}^{(r)} = (-t^{3/4})^{-2jw(b^{\wedge})} (-t^{1/2} - t^{-1/2})^j \langle (b, n) \rangle^{(r-2j)}.$$

Proof. For $g \in G_{rn}$, we put $\langle g \rangle = \langle d(g, n) \rangle \in \mathbb{C}$. By Definition 1.1.10 of the bracket polynomial, the mapping $\langle \cdot \rangle : G_{rn} \rightarrow \mathbb{C}$ is factored by the projection $\Psi_{rn} : G_{rn} \rightarrow J_{rn}$ (see the last paragraph of Section 4.1). Since $p_{rn}(f_1' f_3' \dots f_{2j-1}') = \Psi_{rn}(f_1 f_3 \dots f_{2j-1})$, we have

$$\begin{aligned} \langle (b, n) \rangle_{f_1' f_3' \dots f_{2j-1}'}^{(r)} &= \langle (f_1' f_3' \dots f_{2j-1}' \phi_n^{(r)}(b), rn) \rangle \\ &= \langle (f_1 f_3 \dots f_{2j-1} \phi_n^{(r)}(b), rn) \rangle. \end{aligned}$$

The following lemma shows that the link diagram

$(f_1 f_3 \dots f_{2j-1} \phi_n^{(r)}(b), rn)^\wedge$ is regular isotopic to

$$(\phi_n^{(r-j)}(b), (r-2j)n)^\wedge \cup \left(\bigcup_{i=1}^j (f_1 \sigma_1^{-2w(b^\wedge)}, 2)^\wedge \right) \text{ (disjoint union).}$$

For a link diagram K which is a disjoint union of two link diagrams K_1 and K_2 , it is known that $\langle K \rangle = (-t^{1/2} - t^{-1/2}) \langle K_1 \rangle \langle K_2 \rangle$. It is also known ([16], Proposition 2.5) that $\langle (f_1 \sigma_1^{-2w(b^\wedge)}, 2) \rangle = (-t^{3/4})^{-2w(b^\wedge)}$. Hence we have

$$\begin{aligned} &\langle (f_1 f_3 \dots f_{2j-1} \phi_n^{(r)}(b), rn)^\wedge \rangle \\ &= \langle (\phi_n^{(r-j)}(b), (r-2j)n)^\wedge \cup \left(\bigcup_{i=1, \dots, j} (f_1 \sigma_1^{-2w(b^\wedge)}, 2)^\wedge \right) \rangle \\ &= (-t^{3/4})^{-2jw(b^\wedge)} (-t^{1/2} - t^{-1/2})^j \langle (\phi_n^{(r-j)}(b), (r-2j)n) \rangle, \end{aligned}$$

as required. \square

Lemma 4.2.6. For $b \in B_n$, the link diagram

$(f_1 f_3 \dots f_{2j-1} \phi_n^{(k)}(b), rn)^\wedge$ is regular isotopic to the disjoint union of the link diagrams $(\phi_n^{(r-j)}(b), (r-2j)n)^\wedge$ and j copies of $(f_1 \sigma_1^{-2w(b^\wedge)}, 2)^\wedge$.

Proof. Let $\beta = s_{i(1)}^{(\varepsilon(1))} s_{i(2)}^{(\varepsilon(2))} \dots s_{i(k)}^{(\varepsilon(k))}$ where $3 \leq i(j) \leq r-1$, $1 \leq \varepsilon(j) \leq 1$ ($1 \leq j \leq k$), $s_{i(j)}^{(0)} = f_{i(j)}$, $s_{i(j)}^{(1)} = \sigma_{i(j)}$ and $s_{i(j)}^{(-1)} = \sigma_{i(j)}^{-1}$. Let $\beta^* = s_{i(1)-2}^{(\varepsilon(1))} s_{i(2)-2}^{(\varepsilon(2))} \dots s_{i(k)-2}^{(\varepsilon(k))}$. Then Figure 11 demonstrates that the link diagram $(f_1 \beta \phi_n^{(r)}(b), rn)^\wedge$ is regular isotopic to the disjoint union of the link diagrams $(\beta^* \phi_n^{(r-2)}(b), (r-2)n)^\wedge$ and $(f_1 \sigma_1^{-2w(b^\wedge)}, 2)^\wedge$. Hence an induction on j proves the statement of the lemma. \square

Figure 11.

Lemma 4.2.7. Let $e(j) = e_1 e_3 \dots e_{2j-1} \in J_r$ ($1 \leq j \leq [r/2]$). Let $\chi_{r,i}$ be the character of the representation $\rho_{r,i}$ of J_r , defined in Section 4.1. we have

$$(a) \quad \chi_{r,i}(e(j)) = 0 \quad \text{if } i < j,$$

$$(b) \quad \chi_{r,i}(e(j)) = (-t^{1/2} - t^{-1/2})^j \chi_{r-2j, i-j}(1) \quad \text{if } 0 \leq j \leq i,$$

where we used the convention that $\chi_{0,0}(1) = 1$.

Proof. Since $T_D(e(j)) = j$ by (4.1.7), $\rho_{r,i}(e(j)) = 0$ if $j > i$ and so we get the first formula of the above lemma. We regard J_{r-1} as a subalgebra of J_r by the inclusion homomorphism sending $e_i \in J_{r-1}$ to $e_i \in J_r$ ($1 \leq i \leq r-2$). For an element $x \in J_r$ contained in the subalgebra J_{r-1} , we know [15] that

$$\begin{aligned} \chi_{r,0}(x) &= \chi_{r-1,0}(x), \\ (4.2.8) \quad \chi_{r,i}(x) &= \chi_{r-1,i}(x) + \chi_{r-1,i-1}(x) \quad \text{if } 0 < i < r/2, \\ \chi_{2r,r}(x) &= \chi_{2r-1,r-1}(x). \end{aligned}$$

Using (4.2.8) and Lemma 4.2.9 below, we get the part (b) by induction on r . The details are omitted.

$$\text{Lemma 4.2.9.} \quad \chi_{2r,r}(e(r)) = (-t^{1/2} - t^{-1/2})^r.$$

Proof. By Lemma 4.2.7 (a) and (4.2.8), it is enough to show:

$$(4.2.10) \quad \chi_{2r,r}(e(r)) = (-t^{1/2} - t^{-1/2}) \chi_{2r-1,r-1}(e(r-1)).$$

Let $e(i)'$ be an element of CB_{2r} with $p_{2r}(e(i)') = e(i)$ ($1 \leq i \leq r$).

By Lemma 4.2.7 (a), $\chi_{2r,i}(e(r)) = 0$ if $i < r$ and $\chi_{2r-1,i}(e(r-1)) = 0$ if $i < r-1$. Hence we have

$$V_{2r}(e(r)') = a_{2r,r}(V) \chi_{2r,r}(e(r))$$

and

$$V_{2r-1}(e(r-1)') = a_{2r-1,r-1}(V) \chi_{2r-1,r-1}(e(r-1)).$$

Since $-V$ is a link invariant, we have

$$\begin{aligned} V_{2r}(p_{2r}(\sigma_{2r-1})e(r-1)') &= V_{2r}(p_{2r}(\sigma_{2r-1}^{-1})e(r-1)') = V_{2r-1}(e(r-1)') \\ &\quad \text{(Definition 1.1.2 (ii)).} \end{aligned}$$

Hence, by using

$$e_i = t^{1/2}(t^{1/2} - t^{-1/2})^{-1} p_{2r}(\sigma_i) - t^{-1/2}(t^{1/2} - t^{-1/2})^{-1} p_{2r}(\sigma_i^{-1}),$$

we have

$$\begin{aligned}
 & a_{2r,r}^{(V)} \chi_{2r,r}^{(e(r))} = V(e(r)', 2r) \\
 & = V((t^{1/2}(t^{1/2} - t^{-1/2})^{-1} p_{2r}(\sigma_{2r-1}) - t^{-1/2}(t^{1/2} - t^{-1/2})^{-1} p_{2r}(\sigma_{2r-1}^{-1})) e(r-1)', 2r) \\
 & = V(e(r-1)', 2r-1) = a_{2r-1,r-1}^{(V)} \chi_{2r-1,r-1}^{(e(r-1))}.
 \end{aligned}$$

This and (4.1.11) imply (4.2.10). \square

Proof of Theorem 4.2.1. From Proposition 4.2.4 and Lemma 4.2.7 we have

$$\begin{aligned}
 & \langle (b, n) \rangle_{f_1' f_3' \dots f_{2j-1}'}^{(r)} \\
 & = (-t^{1/2} - t^{-1/2})^j \left(\sum_{i=j}^{\lfloor r/2 \rfloor} \chi_{r-2j, i-j}^{(1)} \langle (b, n) \rangle^{(r, i)} \right) \quad (0 \leq r, 0 \leq j \leq \lfloor r/2 \rfloor).
 \end{aligned}$$

By interchanging r with $r+2j$ and i with $i+j$, we get

$$\begin{aligned}
 & \langle (b, n) \rangle_{f_1' f_3' \dots f_{2j-1}'}^{(r+2j)} \\
 & = (-t^{1/2} - t^{-1/2})^j \left(\sum_{i=0}^{\lfloor r/2 \rfloor} \chi_{r, i}^{(1)} \langle (b, n) \rangle^{(r+2j, i+j)} \right) \quad (0 \leq r, 0 \leq j \leq \lfloor r/2 \rfloor).
 \end{aligned}$$

Hence Proposition 4.2.5 implies that

$$\langle (b, n) \rangle^{(r)} = (-t^{3/4})^{2jw(b^\wedge)} \left(\sum_{i=0}^{\lfloor r/2 \rfloor} \chi_{r, i}^{(1)} \langle (b, n) \rangle^{(r+2j, i+j)} \right).$$

By using (1.1.12), we get $V^{(r)}(b, n) = (-t^{3/4})^{rw(b^\wedge)} \langle (b, n) \rangle^{(r)}$ and $V^{(r, i)}(b, n) = (-t^{3/4})^{rw(b^\wedge)} \langle (b, n) \rangle^{(r, i)}$. Therefore we have

$$V^{(r)}(b, n) = \sum_{i=0}^{\lfloor r/2 \rfloor} \chi_{r, i}^{(1)} V^{(r+2j, i+2j)}(b, n).$$

But the left hand side of the above formula does not depend on j , and so we obtain inductively that

$$v^{(0)}(b, n) = v^{(0,0)}(b, n) = v^{(2,1)}(b, n) = \dots = v^{(2i,i)}(b, n) = \dots,$$

$$v^{(1)}(b, n) = v^{(1,0)}(b, n) = v^{(3,1)}(b, n) = \dots = v^{(1+2i,i)}(b, n) = \dots,$$

...

$$v^{(r)}(b, n) - \sum_{i=1}^{\lfloor r/2 \rfloor} \chi_{r,i}(1) v^{(r,i)}(b, n) \\ = v^{(r,0)}(b, n) = v^{(r+2,1)}(b, n) = \dots = v^{(r+2j,j)}(b, n) = \dots,$$

...

These are the equalities we wanted to show. \square

4.3. The Jones polynomial of satellite links. We give a satellite link version of Theorem 1.6.4 for the one-variable Jones polynomial V .

Definition 4.3.1. Let K and L be diagrams of links in the 3-sphere and the solid torus respectively. Let $N(K)$ the tubular neighborhood of K . Then there is a bijection f , called the faithful embedding, from the solid torus to $N(K)$. This mapping is determined canonically up to ambient isotopy. Let $K_L = f(L)$. Then K_L is a link in the 3-sphere and is called the satellite link of K with respect to L . For a link invariant X , put $X_L(K) = X(K_L)$. Then X_L is a link invariant.

For a link diagram L , let $|L|$ denote the unoriented link diagram obtained by forgetting the orientation of L . For $(g,n) \in G$ (Definition 4.1.13), let $(g,n)^\sim$ be the unoriented link diagram in the annulus obtained by joining the points at the top of $d(g,n)$ and those at the bottom without further crossings as in Figure 12. Conversely, for any link diagram L in the annulus, there is an element $(g,n) \in G$ such that $|L|$ is regular isotopic to $(g,n)^\sim$ in the annulus. Let $\Psi_r: G_r \rightarrow J_r$ be the projection defined in Section 4.1.

Figure 12.

Theorem 4.3.2. Let K be a knot, L an oriented link diagram in the annulus, $w(L)$ the writhe of L , and (g,r) an element of G whose closure is regular isotopic to $|L|$ in the annulus. Then we have

$$V_L(K) = (-t^{3/4})^{w(L)} \sum_{i=0}^{\lfloor r/2 \rfloor} \chi_{r,i}(\Psi_r(g)) V^{(r,i)}(K).$$

Proof. Let $(b,n) \in B$ be a braid whose closure is equivalent to K . Then K_L is equivalent to $(g\phi_n^{(r)}(b), rn)^\wedge$. We regard G_r as a subsemigroup of G_{rn} by the inclusion homomorphism sending $g \in G_r$ to the isotopy class of g' in G_{rn} as in Figure 13.

Figure 13.

By applying the results of Section 1.3 to the wreath product $G_r^n \rtimes G_n$, we get

$$\langle (g\phi_n^{(r)}(b), rn) \rangle = \sum_{i=0}^{\lfloor r/2 \rfloor} \chi_{r,i}(\Psi_r(g)) \langle (b,n) \rangle^{(r,i)}.$$

The proof of this formula is analogous to that of Theorem 1.6.4. We know that $v^{(r,i)}(b,n) = (-t^{3/4})^{w(b^\wedge)} \langle (b,n) \rangle^{(r,i)}$ and $w((g\phi_n^{(r)}(b), rn)^\wedge) = w((g,r)^\wedge) + rw(b^\wedge)$. By using these formulas, the above statement can be proved. \square

Theorem 4.3.2 can be extended for marked links as Theorem 2.5.4.

Example 4.3.3. (doubled knot [33]). Let L_0 be the link diagram in the annulus as in Figure 14.

Figure 14.

Then L_0 is regular isotopic to $(g_0, 4)^\wedge$, where $g_0 = f_1 f_2 f_3 \sigma_2^2$. For a knot K , we have $V_{L_0}(K) = t^{-3/2} ((1-t) V^{(2,0)}(K) - (t^{-1} + t) V^{(0,0)}(K))$ since $\chi_{4,0}(\Psi_4(g_0)) = 0$, $\chi_{4,1}(\Psi_4(g_0)) = 1 - t$ and $\chi_{4,2}(\Psi_4(g_0)) = -(t^{-1} + t)$. But we know that $V^{(2,0)}(K) = V^{(2)}(K) + (t^{-1/2} + t^{1/2})^{-1}$ from Corollary 4.2.3 and so we have $V_{L_0}(K) = t^{-3/2} (1-t) V^{(2)}(K) + t^{-2}$.

4.4. Representations associated with $V^{(r)}$. Let $\rho_{m,k}$ denote the irreducible representation of J_m defined in (4.1.9)-(4.1.10). In this section, $\pi_{3r,i}$ ($0 \leq i \leq [3r/2]$) denote the representations of B_{3r} parametrized by two irreducible representations $\rho_{3r,i}$ of J_{3r} and $\rho_{r,0}$ of J_r defined as in Section 1.4. Let $\omega_{3r,i}$ denote the character of $\pi_{3r,i}$. Let K be a knot equivalent to the closure of a 3-braid $b \in B_3$. Then, by using the following theorem, (4.1.11) and Theorem 1.4.10 (ii), we can calculate $V^{(r,0)}(K)$ explicitly. Moreover, by using Corollary 4.2.3 (i), we may calculate $V^{(r)}(K)$ explicitly.

Theorem 4.4.1. A set of representation matrices of $\pi_{3r,i}(\sigma_j)$ ($0 \leq i \leq [3r/2]$, $j=1,2$) is given by the following.

$$\pi_{3r,i}(\sigma_1) = (\alpha_{i,j,k}^{(t)})_{0 \leq j, k \leq d(r,i)}$$

$$\pi_{3r,i}(\sigma_2) = (\alpha_{i,d(r,i)-j,d(r,i)-k}^{(t)})_{0 \leq j, k \leq d(r,i)}$$

where $d(r,i) = \deg(\pi_{3r,i}) - 1 = i$ (if $0 \leq i \leq r$) or $3r - 2i$ (if $r < i \leq [3r/2]$) and

$$\alpha_{i,j,k}^{(t)} = (-1)^{(r+k)} t^{\gamma(r,i,k,j)} g(i-k, j-k, t) \quad (k \leq j, 0 \leq i \leq r),$$

$$\alpha_{i,j,k}^{(t)} = 0 \quad (j < k, 0 \leq i \leq r),$$

$$\alpha_{i,j,k}^{(t)} = (-1)^{(r+k)} t^{\gamma(r,2r-i,k,j)} g(i-k, j-k, t) \quad (k \leq j, r < i \leq [3r/2]),$$

$$\alpha_{i,j,k}^{(t)} = 0 \quad (j < k, r < i \leq [3r/2]),$$

where $\gamma(r,p,k,j) = (r+k+2rk-k^2+(r-p+j-k)(j-k))/2$ and $g(p,q,t)$ is the Gauss' polynomial. i.e.

$$g(p, q, t) = \prod_{i=1}^q \frac{t^{p+i-1} - 1}{t^i - 1}.$$

The polynomial $g(p, q, t)$ satisfy the following recursive relations:

$$(4.4.2) \quad g(p, 0, t) = 1, \quad g(p, p, t) = 1,$$

$$g(p, q, t) = t^{(p-q)} g(p-1, q-1, t) + g(p-1, q, t).$$

Before proving the above theorem, we give examples and applications.

Example 4.4.3. The representation matrices of $\sigma_1 \in B_3$ for the case $r=2$ and $r=3$ are given in Table 3. The matrices of σ_2 are obtained as follows.

$$\pi_{3r, i}(\sigma_2) = K \pi_{3r, i}(\sigma_1) K, \quad \text{where } K = \begin{pmatrix} 0 & & & 1 \\ & & & \\ & & 1 & \\ & \dots & & \\ 1 & & & 0 \end{pmatrix}.$$

Table 3.

Let $C^* = \{c \in C \mid c \neq 0, c^m \neq 1 \text{ for any } m \in \mathbb{N}\}$.

Proposition 4.4.4. Let (b, b') be a pair of 3-braids such that $w(b^\wedge) = w(b'^\wedge)$ and $V(b^\wedge)(s) = V(b'^\wedge)(s)$ for all $s \in C^*$. Then, for $t \in C^*$, $V^{(2,0)}(b^\wedge)(t) = V^{(2,0)}(b'^\wedge)(t)$ iff $\omega_{6,2}(b)(t) = \omega_{6,2}(b')(t)$.

Proof. Recall that $a_{n,i}(V)(t) \neq 0$ for $0 \leq i \leq [n/2]$ by (4.1.11). From (4.1.10) and Theorem 1.4.10, it is enough to show that

$$(4.4.5) \quad \omega_{6,i}(b)(t) = \omega_{6,i}(b')(t) \quad \text{for } i=0, 1, 3.$$

We have $\omega_{6,i}(b)(t) = \omega_{6,i}(b')(t)$ for $i=1, 3$ and $\chi_{3,0}(b)(t) = \chi_{3,0}(b')(t)$ since they are linear characters of B_3 and $w(b^\wedge) = w(b'^\wedge)$. The assumptions $w(b^\wedge) = w(b'^\wedge)$ and $V(b^\wedge)(s) = V(b'^\wedge)(s)$ for all $s \in \mathbb{C}^*$ yields $\chi_{3,1}(b)(s) = \chi_{3,1}(b')(s)$ since $V(\cdot)(s) = a_{3,0}(V)(s)\chi_{3,0}(\cdot)(s) + a_{3,1}(V)(s)\chi_{3,1}(\cdot)(s)$ for 3-braids. But we know that $\omega_{6,1}(b)(t) = (-1)^{w(b^\wedge)} \chi_{3,1}(b)(t^2)$, and so we have $\omega_{6,1}(b)(t) = \omega_{6,1}(b')(t)$. Hence (4.4.5) is proved. \square

From the above Proposition and Corollary 4.2.3, we have the following.

Corollary 4.4.6. Let (b, b') be a pair of 3-braids such that $w(b^\wedge) = w(b'^\wedge)$ and $V(b^\wedge)(s) = V(b'^\wedge)(s)$ for all $s \in \mathbb{C}^*$. Then, for $t \in \mathbb{C}^*$, $V^{(2)}(b^\wedge)(t) = V^{(2)}(b'^\wedge)(t)$ iff $\omega_{6,2}(b)(t) = \omega_{6,2}(b')(t)$.

Let $P = P(\cdot)(\alpha, q)$ denote the two-variable Jones polynomial with non-zero complex parameters α and q where q is not equal to any roots of unity. Then we have the following.

Corollary 4.4.7. Let (b, b') be a pair of 3-braids such that $w(b^\wedge) = w(b'^\wedge)$, $V(b^\wedge)(s) = V(b'^\wedge)(s)$ and $V^{(2)}(b^\wedge)(s) = V^{(2)}(b'^\wedge)(s)$ for all $s \in \mathbb{C}^*$. Then we have

$$(a) \quad P^{(2, (2))}(b^\wedge)(\alpha, q) = P^{(2, (2))}(b'^\wedge)(\alpha, q),$$

$$(b) \quad P^{(2, (11))}(b^\wedge)(\alpha, q) = P^{(2, (11))}(b'^\wedge)(\alpha, q),$$

$$(c) \quad P^{(2)}(b^\wedge)(\alpha, q) = P^{(2)}(b'^\wedge)(\alpha, q).$$

Proof. The representations $\pi_{\lambda, \nu}$ ($\lambda \in \Lambda(6)$, $\nu = (2) \in \Lambda(2)$) of B_3 associated with $p^{(2)}$ are given in Table 3. With these representation matrices, an analogous argument of the proof of Proposition 4.4.4 shows the part (a). the part (a) and (3.6) implies the part (b). The part (c) follows from the parts (a), (b) and Theorem 1.5.1. \square

Proposition 4.4.8. Let (b, b') be a pair of 3-braids whose closures are knot with $w(b^\wedge) = w(b'^\wedge)$ and $F(b^\wedge)(a, x) = F(b'^\wedge)(a, x)$ for all $a, x \in \mathbb{C}^\times$, where F denotes the Kauffman polynomial. Then, for $t \in \mathbb{C}^*$, $v^{(3,0)}(b^\wedge)(t) = v^{(3,0)}(b'^\wedge)(t)$ iff $\omega_{9,3}(b)(t) = \omega_{9,3}(b')(t)$.

Proof. Because $a_{9,3}(V)(t) \neq 0$, it is enough to show that $\omega_{9,i}(b)(t) = \omega_{9,i}(b')(t)$ for $i=0, 1, 2, 4$. We have $V(b^\wedge)(s) = V(b'^\wedge)(s)$ ($s \in \mathbb{C}^*$) from $F(b^\wedge) = F(b'^\wedge)$ [22]. Thus, as the proof of Proposition 4.4.4, we have $\omega_{9,i}(b)(t) = \omega_{9,i}(b')(t)$ for $i=0, 1, 4$. Let χ be the character of the representation ρ of B_3 defined by the following.

$$\rho(\sigma_1) = \begin{pmatrix} a^{-1} & 0 & x \\ 0 & 0 & -1 \\ 0 & 1 & x \end{pmatrix}, \quad \rho(\sigma_2) = \begin{pmatrix} 0 & -1 & 0 \\ 1 & x & 0 \\ 0 & a^{-1}x & a^{-1} \end{pmatrix}.$$

From Theorem 12.2 of [26] we have $\chi(b)(a, x) = \chi(b')(a, x)$ if the values of a and x are generic. This yields $\chi(b)(a, x) = \chi(b')(a, x)$ for all $a, x \in \mathbb{C}^\times$ since $\chi(\beta)(a, x)$ are Laurent polynomials of the parameters a and x for all $\beta \in B_3$. Let χ' be the character obtained from χ by substituting $x = -t^{-3/2} + t^{3/2}$ and $a = t^{-7/2}$. Then $\omega_{9,2}(\cdot)(t) = t^3 \chi'(\cdot)(t)$ and so we have $\omega_{9,2}(b)(t) = \omega_{9,2}(b')(t)$. This proves the proposition. \square

From the above proposition and Corollary 4.2.3, we have the following.

Corollary 4.4.9. Let (b, b') be a pair of 3-braids whose closures are knot with $w(b^\wedge) = w(b'^\wedge)$ and $F(b^\wedge)(a, x) = F(b'^\wedge)(a, x)$ for all $a, x \in \mathbb{C}^\times$, where F denotes the Kauffman polynomial. Then, for $t \in \mathbb{C}^*$, $V^{(3)}(b^\wedge)(t) = V^{(3)}(b'^\wedge)(t)$ iff $\omega_{9,3}(b)(t) = \omega_{9,3}(b')(t)$.

Proposition 4.4.10. The invariant $V^{(3)}$ is independent from V , $V^{(2)}$, and the Kauffman polynomial F .

Proof. We give a pair of braids (b, b') such that $V(b^\wedge) = V(b'^\wedge)$, $V^{(2)}(b^\wedge) = V^{(2)}(b'^\wedge)$, $F(b^\wedge) = F(b'^\wedge)$ but $V^{(3)}(b^\wedge) \neq V^{(3)}(b'^\wedge)$. Let

$$b(m, n) = \sigma_1^2 \sigma_2^{-2} \sigma_1 \sigma_2^2 \sigma_1^{-2} \sigma_2^m \sigma_1^2 \sigma_2^{-2} \sigma_1^{-1} \sigma_2^2 \sigma_1^{-2} \sigma_2^n,$$

for odd integers m, n . Then T.Kanenobu noted that the knots $b(m, n)^\wedge$ and $b(n, m)^\wedge$ have the same Kauffman polynomial. Therefore they have the same Jones polynomial [22] and the same 2-parallel version of the Jones polynomial [35]. But T.Kanenobu conjectured that $b(m, n)^\wedge$ and $b(n, m)^\wedge$ are not equivalent except a finite number of pairs (m, n) . From a calculation with a computer we have $\omega_{9,3}(b(3,1)) \neq \omega_{9,3}(b(1,3))$ by substituting 4 to the parameter t . Thus we have $V^{(3)}(b(1,3)^\wedge) \neq V^{(3)}(b(3,1)^\wedge)$ from Corollary 4.4.9. \square

From now on, we prepare some notations which is needed in the proof of Theorem 4.1.1. We use the notations in Section 4.1. Fix an integer i with $0 \leq i \leq \lfloor 3r/2 \rfloor$. Let

$$V_{3r,i} = J_{3r,i} e_1 e_3 \dots e_{2i-1} / (J_{3r,i} e_1 e_3 \dots e_{2i-1} \cap J_{3r,i+1}^*).$$

From Proposition 4.1.9, $V_{3r,i}$ is an irreducible left J_{3r} -module and the left action of J_{3r} on $V_{3r,i}$ are equivalent to $\rho_{r,i}$. By Proposition 4.1.6, there is a subset $G_{3r,i}$ of E_{3r} such that $\{x \text{ MOD } J_{3r,i+1} \mid x \in G_{3r,i}\}$ is a basis of $V_{3r,i}$. More precisely, $G_{3r,i} = E_{r,i} \cap J_{3r} e_1 e_3 \dots e_{2i-1}$. Let

$$G_{3r,i,1} = \{x \in G_{3r,i} \mid \text{there is } j \neq 0 \pmod{r} \text{ such that the } j\text{-th point at the top of } \eta(x) \text{ is connected to the } (j+1)\text{-th point at the top of } \eta(x)\},$$

and $V_{3r,i,1}$ the subspace of $V_{3r,i}$ spanned by the image of $G_{3r,i,1}$. For $0 \leq j_1, j_2, j_3 \leq [r/2]$, let V_{3r,i,j_1,j_2,j_3} be the $\rho_{r,j_1} \otimes \rho_{r,j_2} \otimes \rho_{r,j_3}$ -isotypic subspace with respect to $J_r^{\otimes 3}$ naturally embedded in J_{3r} (see Section 1.4). Let $I = \{k \mid 1 \leq k \leq 3r-1, k \neq 0 \pmod{r}\}$ and J_I the subalgebra of J_{3r} generated by e_k ($k \in I$). Let λ_0 denote the one-dimensional representation of J_I defined by $\lambda_0(e_k) = 0$ ($k \in I$).

For a J_I -module U , let $U_+ = \sum_{k \in I} e_k U$. Then U_+ is a J_I -submodule of

U . Let U_0 denote the λ_0 -isotypic subspace of U . Since $-(t^{1/2} + t^{-1/2})^{-1} e_k$ ($k \in I$) is a projection and $U_0 =$

$\bigcap_{k \in I} (1 + (t^{1/2} + t^{-1/2})^{-1} e_k) U$, we have the following.

Proposition 4.4.11. The composition of natural homomorphisms $U_0 \rightarrow U \rightarrow U/U_+$ is a J_I -module isomorphism.

From Proposition 4.1.8, we have $V_{3r,i,1} = \sum_{k \in I} e_k V_{3r,i}$. Since J_I is isomorphic to $J_r^{\otimes 3}$, we get the following.

Corollary 4.4.12. The $J_r^{\otimes 3}$ -submodule $V_{3,i,0,0,0}$ of $V_{r,i}$ is isomorphic to $V_{3r,i} / V_{3r,i,1}$ as a $J_r^{\otimes 3}$ -module.

Let $V_{3r,i,0} = V_{3r,i} / V_{3r,i,1}$. Then the above corollary implies that the representation $\pi_{3r,i}$ of B_3 in Theorem 4.4.1 is equivalent to the action of B_3 on $V_{3r,i,0}$ induced by restricting the representation $\rho_{3r,i} \circ \phi_3^{(r)}$. We give a basis of $V_{3r,i,0}$ and representation matrices of $\pi_{3r,i}$ with respect to the above basis. For $0 \leq k, m < j$, let

$$e^{(d)}(j-k, j+k, j-m, j+m) = \begin{cases} e(j-k, j+k) e(j-k-1, j+k+1) \dots e(j-m, j+m) & \text{if } m \geq k, \\ e(j-k, j+k) e(j-k+1, j+k-1) \dots e(j-m, j+m) & \text{if } m < k, \end{cases}$$

and

$$e^{(h)}(j-k, j+m, j-m, j+k) = e(j-k, j+m) e(j-k-1, j+m-1) \dots e(j-m, j+k).$$

Let $H_{r,i} = \{h_{r,i,j} \mid 0 \leq j \leq i \text{ if } i \leq r \text{ and } i-r \leq j \leq 2r-i \text{ if } r < i\}$, where the elements $h_{r,i,j}$ are given as follows. In the case of $0 \leq i \leq r$, let

$$h_{r,i,j}^{(1)} = e^{(d)}(r, r, r-j+1, r+j-1),$$

$$h_{r,i,j}^{(2)} = e^{(d)}(2r, 2r, 2r-i+j+1, 2r+i-j-1),$$

$$h_{r,i,j}^{(3)} = e^{(h)}(2r-i+j, 2r+i-j-2, r+j+1, r-j+2i-1),$$

$$h_{r,i,j}^{(4)} = e^{(h)}_{(r+j, r-j+2i-2, 1, 2i-2j-1)},$$

$$h_{r,i,j} = h_{r,i,j}^{(1)} h_{r,i,j}^{(2)} h_{r,i,j}^{(3)} h_{r,i,j}^{(4)},$$

for $0 \leq j \leq i$. In the case of $r < i \leq [3r/2]$, let

$$h_{r,i,j}^{(1)} = e^{(d)}_{(r, r, r-j+1, r+j-1)},$$

$$h_{r,i,j}^{(2)} = e^{(d)}_{(2r, 2r, r+j+1, 3r-j-1)},$$

$$h_{r,i,j}^{(3)} = e^{(d)}_{(r-j, 3r-j, 2r-i-j+1, 2r+i-j-1)},$$

$$h_{r,i,j}^{(4)} = e^{(h)}_{(2r-i-j, 2r+i-j-2, 1, 2i-1)},$$

$$h_{r,i,j} = h_{r,i,j}^{(1)} h_{r,i,j}^{(2)} h_{r,i,j}^{(3)} h_{r,i,j}^{(4)},$$

for $i-r \leq j \leq 2r-i$. The rectangular diagrams of $\eta(h_{r,i,j}) \in D_{3r}$ are given as in Figure 15.

Figure 15.

Let $W_{3r,i}$ denote the inverse image of $V_{3r,i,1}$ with respect to the canonical projection

$$J_{3r} e_1 e_3 \dots e_{2i-1} \rightarrow J_{3r} e_1 e_3 \dots e_{2i-1} / (J_{3r,i+1} \cap J_{3r} e_1 e_3 \dots e_{2i-1}).$$

Proposition 4.4.13. The set $H_{r,i}^\bullet = \{h \bmod W_{3r,i} \mid h \in H_{r,i}\}$ is a basis of $V_{3r,i,0}$.

Proof. For $h \in H_{r,i}$, we know that $h \in E_{3r,i}$, $h \in J_{3r} e_1 e_3 \dots e_{2i-1}$, $h \notin E_{3r,i+1}$ and $h \notin E_{3r,i,1}$. Hence $H_{r,i}^\bullet$ is linearly independent since $W_{3r,i}$ is a subspace of $J_{r,i}^\bullet$ spanned by $(E_{r,i+1} \cap J_{3r} e_1 e_3 \dots e_{2i-1}) \cup E_{r,i,1}$. Since the dimension of the representation

$\rho_{r,0}^{\otimes 3}$ of $J_r^{\otimes 3}$ is equal to one, the dimension of the $\rho_{r,0}^{\otimes 3}$ -isotypic subspace of $V_{3r,i}$ with respect to $J_r^{\otimes 3}$ is equal to the multiplicity of $\rho_{r,0}^{\otimes 3}$ in $\rho_{3r,i}|_{J_r^{\otimes 3}}$. From Remarks 4.1.12 and 3.8, we may use the Littlewood-Richardson rule (Remark 3.8) for computing $\dim_{\mathbb{C}} V_{3r,i,0}$. The result is

$$\dim_{\mathbb{C}} V_{3r,i,0} = i+1 \text{ if } 0 \leq i \leq r \text{ and } 2r-i+1 \text{ if } r < i \leq [3r/2],$$

which are equal to $\#H_{r,i}$. This shows that $H_{3r,i}$ is a basis of $V_{3r,i,0}$. \square

Let $p_{3r}: B_{3r} \rightarrow J_{3r}$ be the algebra homomorphism introduced in Section 4.1. We use the following formulas in the proof of Theorem 4.4.1, which can be proved immediately from the definitions of J_{3r} , p_{3r} and $W_{3r,i}$. For $v \in J_r e_1 e_3 \dots e_{2i-1}$ and $1 \leq k \leq 3r-1$ with $k \neq 0 \pmod{r}$, we have

$$(4.4.14) \quad p_{3r}(\sigma_i) v = -t^{1/2} v \pmod{W_{3r,i}}.$$

For $1 \leq k \leq 3r-1$, we have

$$(4.4.15) \quad p_{3r}(\sigma_i) e_i = e_i p_{3r}(\sigma_i) = t^{3/2} e_i.$$

For $1 \leq k \leq 3r-2$, we have

$$\begin{aligned}
& p_{3r}(\sigma_i) e_{i+1} e_i = t^{3/2} p_{3r}(\sigma_{i+1})^{-1} e_i, \quad p_{3r}(\sigma_{i+1}) e_i e_{i+1} = t^{3/2} p_{3r}(\sigma_i)^{-1} e_{i+1}, \\
& p_{3r}(\sigma_i)^{-1} e_{i+1} e_i = t^{-3/2} p_{3r}(\sigma_{i+1}) e_i, \quad p_{3r}(\sigma_{i+1})^{-1} e_i e_{i+1} = t^{-3/2} p_{3r}(\sigma_i) e_{i+1}, \\
(4.4.16) \quad & p_{3r}(\sigma_i) e_{i+1} p_{3r}(\sigma_i)^{-1} = p_{3r}(\sigma_{i+1})^{-1} e_i p_{3r}(\sigma_{i+1}), \\
& p_{3r}(\sigma_i)^{-1} e_{i+1} p_{3r}(\sigma_i) = p_{3r}(\sigma_{i+1}) e_i p_{3r}(\sigma_{i+1})^{-1}.
\end{aligned}$$

We also need following formulas, which can be proved by using above formulas. For $p, q \in \mathbb{N}$ with $p \leq q$, let

$$\begin{aligned}
\sigma(p, q) &= \sigma_p \sigma_{p+1} \dots \sigma_q, & \sigma^-(p, q) &= \sigma_p^{-1} \sigma_{p+1}^{-1} \dots \sigma_q^{-1}, \\
\sigma^+(q, p) &= \sigma_q \sigma_{q-1} \dots \sigma_p & \text{and } \sigma'^-(q, p) &= \sigma_q^{-1} \sigma_{q-1}^{-1} \dots \sigma_p^{-1}.
\end{aligned}$$

For $0 \leq k \leq m < j$, let

$$\sigma(j \pm k, j+m, j-m, j \mp k) = \sigma(j \pm k, j+m) \sigma(j \pm k-1, j+m-1) \dots \sigma(j-m, j \mp k).$$

and

$$\sigma^-(j \pm k, j+m, j-m, j \mp k) = \sigma^-(j \pm k, j+m) \sigma^-(j \pm k-1, j+m-1) \dots \sigma^-(j-m, j \mp k).$$

For $j, k, m, n \in \mathbb{N}$ with $j > m-k+n$, we have

$$\begin{aligned}
(4.4.17) \quad & \sigma(j-k+m, j+m+n-1, j-k+1, j+n) \sigma(j-k, j-k-n+1, j-1, j-n) \\
& e^{(d)}(j, j, j-n+1, j+n-1) \\
& = \sigma^-(j-k, j-k+1, j-k+m-1, j-k-n+m) \sigma(j-k+m, j+m-1, j-k-n+1, j-n) \\
& e^{(d)}(j+m, j+m, j+m-n+1, j+m+n-1) e^{(h)}(j+m-n, j+m+n-2, j-n+1, j+n-1)
\end{aligned}$$

For $j, k \in \mathbb{N}$, we have

$$\begin{aligned}
(4.4.18) \quad & \sigma_i^{\pm 1} e(i+2, i+2k) e(i+1, i+2k-1) e(i, i+2k-2) \\
& = e(i+2, i+2k) e(i+1, i+2k-1) e(i, i+2k-2) \sigma_{i+2k}^{\pm 1}.
\end{aligned}$$

Formula (4.4.17) with $m=1$, (4.4.15), (4.4.16) and (4.4.18) implies that

$$\begin{aligned}
(4.4.19) \quad & \sigma(j, j+k-1) \sigma'(j-1, j-k+1) e^{(d)}(j, j, j-k+1, j+k-1) \\
= & t^{3/2} t^{3(k-1)} \sigma'^{-}(j-1, j-k+1) \sigma'(j-1, j-k+1)^{-1} e^{(d)}(j, j, j-k+1, j+k-1).
\end{aligned}$$

An induction on m and (4.4.19) shows that

$$\begin{aligned}
(4.4.20) \quad & \sigma(j, j-m+1, j+m-1, j) e^{(d)}(j, j, j-m+1, j+m-1) \\
= & (t^{3/2})^{m^2} \sigma'^{-}(j-1, j-m+1) \sigma'(j-1, j-m+1)^{-1} \sigma'^{-}(j-2, j-m+1) \sigma'(j-2, j-m+1)^{-1} \\
& \dots \sigma'^{-}(j-m, j-m) \sigma'(j-m, j-m)^{-1} e^{(d)}(j, j, j-m+1, j+m-1).
\end{aligned}$$

Proof of Theorem 4.4.1. We calculate the representation matrices of $\pi_{3r,i}(\sigma_j)$ ($j=1,2$) with respect to the basis $H_{3r,i}$. This can be done by writing down $p_{3r}(\phi_3^{(r)}(\sigma_j))h_{r,i,k} \pmod{W_{3r,i}}$ ($j=1,2$) as \mathbb{C} -linear combinations of elements of $H_{3r,i}$. Steps 1-7 can be proved by using formulas (4.4.14)-(4.4.20).

$$\begin{aligned} \text{Step 1. } & p_{3r}(\phi_3^{(r)}(\sigma_j))h_{r,i,k} \\ & \equiv (-t^{1/2})^{r(r-1)} \sigma(r, 2r-1, 1, r) h_{r,i,k} \pmod{W_{3r,i}}. \end{aligned}$$

$$\begin{aligned} \text{Step 2. } & \sigma(r, 2r-1, 1, r) h_{r,i,k} \\ & \equiv (t^{3/2})^{k^2} \sigma(r, 2r-1, k+1, r+k) \sigma(k, r-1, 1, r-k) \\ & \quad \sigma'^{-}(r-1, r-k+1) \sigma'(r-1, r-k+1)^{-1} \sigma'^{-}(r-2, r-k+2) \sigma'(r-2, r-k+2)^{-1} \\ & \quad \dots \sigma'^{-}(r-k+1, r-k+1) \sigma'(r-k+1, r-k+1)^{-1} h_{r,i,k} \pmod{W_{3r,i}}. \end{aligned}$$

$$\begin{aligned} \text{Step 3. } & \sigma(r, 2r-1, k+1, r+k) \sigma(k, r-1, 1, r-k) \\ & \quad \sigma'^{-}(r-1, r-k+1) \sigma'(r-1, r-k+1)^{-1} \sigma'^{-}(r-2, r-k+2) \sigma'(r-2, r-k+2)^{-1} \\ & \quad \dots \sigma'^{-}(r-k+1, r-k+1) \sigma'(r-k+1, r-k+1)^{-1} h_{r,i,k} \\ & \equiv (-t^{-1/2})^{k(k-1)} \sigma(r, 2r-1, k+1, r+k) \sigma(k, r-1, 1, r-k) h_{r,i,k} \pmod{W_{3r,i}}. \end{aligned}$$

$$\begin{aligned} \text{Step 4. } & \sigma(r, 2r-1, k+1, r+k) \sigma(k, r-1, 1, r-k) h_{r,i,k}^{(2)} \\ & \equiv t^{3k(r-k)/2} \sigma^-(k, r-1, 1, r-k) \sigma(r, 2r-k-1, r-k+1, 2r-2k) \sigma(r-k, 2r-2k-1, 1, r-k) \\ & \quad e^{(d)}(2r-k, 2r-k, 2r-2k+1, 2r-1) e^{(h)}(2r-2k, 2r-2, r-k+1, r+k-1). \end{aligned}$$

$$\begin{aligned}
& \text{Step 5. } \sigma^-(k, r-1, 1, r-k) \sigma(r, 2r-k-1, 1, r-k) e^{(d)}(2r-k, 2r-k, 2r-2k+1, 2r-1) \\
& e^{(h)}(2r-2k, 2r-2, r-k+1, r+k-1) e^{(d)}(2r, 2r, 2r-i+k+1, 2r+i-k-1) \\
& e^{(h)}(2r-i+k, 2r+i-k-2, r+k+1, r-k+2i-1) e^{(h)}(r-k, r-k+2i-2, 1, 2i-1) \\
& \equiv (-t^{-1/2})^{k(r-k)} \sigma(r-k, 2r-2k-1, 1, r-k) e^{(d)}(2r-k, 2r-k, 2r-i-k+1, 2r+i-k-1) \\
& e^{(h)}(2r-i-k, 2r+i-k-2, 1, 2i-1) \pmod{W_{3r, i}}.
\end{aligned}$$

$$\begin{aligned}
& \text{Step 6. } \sigma(r-k, 2r-2k-1, 1, r-k) e^{(d)}(2r-k, 2r-k, 2r-i-k+1, 2r+i-k-1) \\
& e^{(h)}(2r-i-k, 2r+i-k-2, 1, 2i-1) \\
& \equiv t^{3i(r-k)/2} (-t^{1/2})^{(r-i)(r-k)-k(r-k)} \sigma^-(2r, r+k+1, 2r+i-k-1, r+i) \\
& e^{(d)}(r, r, r-i+1, r+i-1) e^{(h)}(r-i, r+i-2, 1, 2i-1) \pmod{W_{3r, i}}.
\end{aligned}$$

Step 7. For non-negative integers i, k and m such that $k < i$ and $m < i - k$, we have

$$\begin{aligned}
& e^{(d)}(2r, 2r, 2r+m-2, 2r-m+2) e^{(h)}(2r-m+1, 2r+m-1, r+k+1, r+k+2m-1) \\
& \sigma^-(2r+m, r+k+2m+1, 2r+i-k-1, r+i+m) e^{(d)}(r, r, r-k+1, r+k-1) \\
& e^{(d)}(r-k, r+k+2m, r-i+m+1, r+i+m-1) e^{(h)}(r-i+m, r+i+m-2, 1, 2i-1) \\
& \equiv (-t^{-1/2})^{(r-2k-2m+i-1)} e^{(d)}(2r, 2r, 2r+m-2, 2r-m+2) \\
& e^{(h)}(2r-m+1, 2r+m-1, r+k+2, r+k+2m) \sigma^-(2r+m, r+k+2m+2, 2r+i-k-2, r+i+m) \\
& e^{(d)}(r, r, r-k, r+k) e^{(d)}(r-k-1, r+k+2m+1, r-i+m+1, r+i+m-1) \\
& e^{(h)}(r-i+m, r+i+m-2, 1, 2i-1)
\end{aligned}$$

$$\begin{aligned}
& + (-t^{-1})^{(r-2k-2m+i-1)} e^{(d)}(2r, 2r, 2r+m-1, 2r-m+1) \\
& e^{(h)}(2r-m, 2r+m, r+k+1, r+k+2m+1) \sigma^{-}(2r+m+1, r+k+2m+3, 2r+i-k-1, r+i+m+1) \\
& e^{(d)}(r, r, r-k+1, r+k-1) e^{(d)}(r-k, r+k+2m+2, r-i+m+2, r+i+m) \\
& e^{(h)}(r-i+m+1, r+i+m-1, 1, 2i-1) \pmod{W_{3r, i}}.
\end{aligned}$$

Step 7 implies the following.

$$\begin{aligned}
\text{Step 8. } & e^{(d)}(2r, 2r, 2r+m-2, 2r-m+2) e^{(h)}(2r-m+1, 2r+m-1, r+k+1, r+k+2m-1) \\
& \sigma^{-}(2r+m, r+k+2m+1, 2r+i-k-1, r+i+m) e^{(d)}(r, r, r-k+1, r+k-1) \\
& e^{(d)}(r-k, r+k+2m, r-i+m+1, r+i+m-1) e^{(h)}(r-i+m, r+i+m-2, 1, 2i-1) \\
& = \sum_{j=k}^i \beta_{k, m, j} h_{r, i, j}'
\end{aligned}$$

where $\beta_{k, m, j}$ ($0 \leq m \leq i-k$) satisfy the following relations.

$$\begin{aligned}
(4.4.21) \quad & \beta_{k, i-k, k} = 1 \quad (0 \leq k \leq i), \quad \beta_{k, i-k, j} = 0 \quad (0 \leq j \leq i, j \neq k), \\
& \beta_{k, m, j} = (-t^{-1/2})^{(r-2k-2m+i-1)} \beta_{k+1, m, j} + (-t^{-1})^{(r-2k-2m+i-1)} \beta_{k, m+1, j} \\
& \qquad \qquad \qquad (0 \leq m < i-k).
\end{aligned}$$

Step 9. For $0 \leq k \leq j$ and $0 \leq m \leq i-j$, we have

$$\begin{aligned}
& \beta_{k, m, j} \\
& = (-1)^{(r-i+1)(i-k-m)} (t^{-1/2})^{(r-i+j-k)(j-k)+2(r+j-2k-m)(i-j-m)} g_{i-k-m, j-k}(t).
\end{aligned}$$

Especially, we have

$$\beta_{k, 0, j} = (-1)^{(r-i+1)(i-k)} (t^{-1/2})^{(r-i+j-k)(j-k)+2(r+j-2k)(i-j)} g_{i-k, j-k}(t).$$

PROOF. since

$$(-1)^{(r-i+1)(i-k-m)} (t^{-1/2})^{(r-i+j-k)(j-k)+2(r+j-2k-m)(i-j-m)} g_{i-k-m, j-k}^{(t)}$$

satisfy the relation (4.4.21), these are identical to $\beta_{k,m,j}$.

Step 10. Combining the results of Steps 1-9, we get the statement of Theorem 4.4.1 for the case $0 \leq i \leq r$. An analogous argument proves the statement of the theorem for the case $r < i \leq \lfloor 3r/2 \rfloor$.

5. The parallel version of the Kauffman polynomial. The associated algebras C_1, C_2, \dots of the Kauffman polynomial F (Definition 1.1.10) are obtained in [2] and [26]. The invariant F is known to be of trace type if the values of the parameters a and x are generic. Therefore we can apply our theory in Section 1 to F with generic parameters. We give a formula for the Kauffman polynomials of satellite links (Theorem 5.3.1).

5.1. The associated algebra C_n . Let $a, \beta \in \mathbb{C} \setminus \{0\}$ such that β is not equal to any roots of unity. Let $x = \beta - 1/\beta$. The associated algebra C_n of the Kauffman polynomial is defined as a \mathbb{C} -algebra with 1 by the following.

$$(5.1.1) \quad C_n =$$

$$\langle \tau_i, \tau_i^{-1}, \varepsilon_i \ (1 \leq i \leq n-1) \mid \tau_i \tau_{i+1} \tau_i = \tau_{i+1} \tau_i \tau_{i+1},$$

$$\varepsilon_i \varepsilon_{i+1} \varepsilon_i = \varepsilon_i, \quad \varepsilon_{i+1} \varepsilon_i \varepsilon_{i+1} = \varepsilon_{i+1},$$

$$\tau_i^{\pm 1} \varepsilon_{i+1} \varepsilon_i = \tau_{i+1}^{\mp 1} \varepsilon_i, \quad \tau_{i+1}^{\pm 1} \varepsilon_i \varepsilon_{i+1} = \tau_i^{\mp 1} \varepsilon_{i+1},$$

$$\varepsilon_i \varepsilon_{i+1} \tau_i^{\pm 1} = \varepsilon_i \tau_{i+1}^{\mp 1}, \quad \varepsilon_{i+1} \varepsilon_i \tau_{i+1}^{\pm 1} = \varepsilon_{i+1} \tau_i^{\mp 1} \quad (1 \leq i \leq n-2),$$

$$\tau_i \tau_j = \tau_j \tau_i, \quad \varepsilon_i \tau_j = \tau_j \varepsilon_i, \quad \varepsilon_i \varepsilon_j = \varepsilon_j \varepsilon_i \quad (1 \leq i \leq j-1 \leq n-2),$$

$$\tau_i - \tau_i^{-1} = x(1 - \varepsilon_i), \quad \tau_i \varepsilon_i = \varepsilon_i \tau_i = a^{-1} \varepsilon_i, \quad \tau_i \tau_i^{-1} = \tau_i^{-1} \tau_i = 1 \quad (1 \leq i \leq n-1) \rangle.$$

This definition is equivalent to that in [2]. Let $C_{n,i} =$

$C_n e_1 e_3 \dots e_{2i-1} C_n$. Then $C_{n,i}$ is a two sided ideal and satisfies $C_n =$

$C_{n,0} \supset C_{n,1} \supset \dots \supset C_{n,[n/2]}$. Let $D_{n,i} = C_{n,i} / C_{n,i+1}$ ($0 \leq i \leq [n/2]-1$) and

$D_{n,[n/2]} = C_{n,[n/2]}$. Note that

(5.1.2) $D_{n,0} \cong H_n((-1)^{-1/2}\beta)$ (the Iwahori's Hecke algebra of type A_{n-1}).

Let $c_{n,i} = \binom{n}{2} \binom{n-2}{2} \dots \binom{n-2i}{2} / (i!)$. For $\mu \in \Lambda(n)$, let $d(\mu)$ denote the degree of the character χ_μ of H_n parametrized by the partition μ . Then we have ([2], Theorem 3.7)

$$(5.1.3) \quad D_{n,i} \cong \bigoplus_{\mu \in \Lambda(n-2i)} M_{d(\mu)c_{n,i}}(\mathbb{C}) \quad (0 \leq i \leq [n/2]).$$

Hence the irreducible representations of $D_{n,i}$ are parametrized by $\Lambda(n-2i)$ and so

$$(5.1.4) \quad \hat{C}_n = \{(i, \mu) \mid 0 \leq i \leq [n/2], \mu \in \Lambda(n-2i)\}.$$

Let $\rho_{i,\mu}$ denote the corresponding irreducible representation of (i, μ) and $\chi_{i,\mu}$ its character. Let $p'_n : CG_n \rightarrow C_n$ be the homomorphism defined by $p'_n(\sigma_i) = \tau_i$, $p'_n(\sigma_i^{-1}) = \tau_i^{-1}$, $p'_n(f_i) = \varepsilon_i$, and $p_n : CB_n \rightarrow C_n$ the homomorphism defined by $p_n(\sigma_i) = a\tau_i$ and $p_n(\sigma_i^{-1}) = a^{-1}\tau_i^{-1}$ for $1 \leq i \leq n-1$. Then the main result of [2] can be reformulated as follows.

Theorem 5.1.5. For an n -braid b , there are $a_{i,\mu}(F) \in \mathbb{C}$ ($0 \leq i \leq [n/2]$, $\mu \in \Lambda(n-2i)$) such that

$$F((b,n)^\wedge) = \sum_{(i,\mu) \in \hat{C}_n} a_{i,\mu}(F) \chi_{i,\mu}(p_n(b)).$$

The coefficients $a_{i,\mu}(F)$ are given explicitly in [28].

5.2. Relations among the invariants associated with the decomposition of $F^{(r)}$. Let $F^{(r, (i, \mu))}$ denote the invariant associated with the decomposition of the r -parallel version $F^{(r)}$ of the Kauffman polynomial F parametrized by $(i, \mu) \in C_n^\wedge$ (5.1.4) as in Section 1.3. In this section we show that one of the above invariants are the same one. In the following we use the conventions that $F^{(0)}(K) = F^{(0, (0, \phi))}(K) = (-1 + (a + a^{-1})/x)^{-1}$ for any link diagram K .

Theorem 5.2.1. Let K be a knot. Then we have

$$F^{(r, (i, \mu))}(K) = F^{(r-2k, (i-k, \mu))}(K) \quad \text{for } 0 \leq r, 0 \leq i \leq [r/2], 0 \leq k \leq i.$$

Corollary 5.2.2. Let K be a knot. Then we have

$$F^{(r)}(K) = \sum_{i=0}^{[r/2]} \sum_{\mu \in \Lambda(r-2i)} \chi_{i, \mu}(1) F^{(r-2i, (0, \mu))}(K).$$

The above results may be generalized to the case of marked links.

We may prove Theorem 5.2.1 by an analogous argument used in the proof of Theorem 4.2.1. We use the D -polynomial instead of the bracket polynomial. In this case, the following lemma takes the role of Lemma 4.2.7 in the proof of Theorem 4.2.1.

Lemma 5.2.3. Let $e(j) = e_1 e_3 \dots e_{2j-1} \in C_r$ ($1 \leq j \leq [r/2]$). For the character $\chi_{i, \mu}$ of the representation $\rho_{i, \mu}$ of C_r , we have

$$(a) \quad \chi_{i, \mu}(e(j)) = 0 \quad \text{if } i < j,$$

$$(b) \quad \chi_{i, \mu}(e(j)) = (1 - (a - a^{-1})/x)^j \chi_{i-j, \mu}(1) \quad \text{if } 1 \leq j \leq i,$$

where $\chi_{i-j, \mu} \in C_{r-2j}^\wedge$ and we use the convention that $\chi_{0, \phi}(1) = 1$.

To prove this lemma, we use the following formula in [2]. For $\mu = (\mu_1, \mu_2, \dots) \in \Lambda(n)$ and $\mu' = (\mu'_1, \mu'_2, \dots) \in \Lambda(n-1)$, we denote $\mu' < \mu$ iff $\mu'_i \leq \mu_i$ for all $i \in \mathbb{N}$. For $y \in C_{r-1}$, $0 \leq i \leq [r/2]$ and $\mu \in \Lambda(r-2i)$, we have

$$(5.2.4) \quad \chi_{i,\mu}(y) = \left(\sum_{\substack{\mu' \in \Lambda(r-2i-1), \\ \mu' < \mu}} \chi_{i,\mu'}(y) \right) + \left(\sum_{\substack{\mu'' \in \Lambda(r-2i+1), \\ \mu < \mu''}} \chi_{i-1,\mu''}(y) \right).$$

The details of proofs of Theorem 5.2.1 and Lemma 5.2.3 are omitted.

5.3. The Kauffman polynomial of satellite links. In the case of the Kauffman polynomial, we have a formula for satellite links as in the case of the one-variable Jones polynomial (discussed in Section 4.3).

Theorem 5.3.1. Let K be a knot, L a link diagram in the annulus, and (g,r) an element of G whose closure is regular isotopic to $|L|$. Let $F_L(K) = F(K_L)$, where K_L is the satellite link of K with respect to L . Then we have

$$F_L(K) = a^{-w(L)} \left(\sum_{(i,\mu) \in C_r} \chi_{i,\mu}(p_r'(g)) F^{(i,\mu)}(K) \right).$$

The proof is similar to that of Theorem 4.3.2 and we omit it. This theorem may be generalized to the case of marked links.

Example 5.3.2 (doubled knot [33]). Let L_0 be the link diagram in the annulus as in Figure 14. Then as in Example 4.3.3, $|L_0|$ is regular isotopic to $(g_0, 4)^-$, where $g_0 = f_1 f_2 f_3 \sigma_2^2$. For a knot K , we have $F_{L_0}(K) = -a^{-2} x (\beta^{-1} + a^{-1}) F^{(2, (0, (2)))}(K) + a^{-2} x (\beta - a^{-1}) F^{(2, (0, (11)))}(K) + a^{-2} (x^3 (a - a^{-1} - x)^{-1} + x^2 + 1)$ by calculating $\chi_{i, \mu}(g_0)$ for $(i, \mu) \in C_4^\wedge$.

6. Mutation and the r -parallel version of a link invariant. Let K and K' be two distinct mutant links (Definition 6.2.3). We are interested in comparing the r -parallel versions $X^{(r)}(K)$ and $X^{(r)}(K')$ of a link invariant X . In the case of the (two-variable) Jones polynomial V , P and the Kauffman polynomial F , it is already known [23], [25] that none of $V^{(r)}$, $P^{(2)}$, and $F^{(2)}$ can distinguish two mutant knots. But it is announced [25] that the Kinoshita-Terasaka knot and the Conway's 11-crossing knot, which are mutant, have distinct $P^{(3)}$. We can show that there are four mutant knots having distinct $P^{(3)}$.

6.1. Tangles.

Definition 6.1.1. Let n be a positive integer. An oriented rectangular diagram T which consists of oriented curves is called a n -tangle iff T contains some or no closed curves, and n non-closed curves starting at the top of the rectangle and terminating at the bottom of it (Figure 16). Two n -tangles T and S are called isotopic if there is a sequence of Reidemeister moves from T to S . We denote R_n the set of isotopy classes of n -tangles. A closure of an n -tangle T , written T^\wedge , is the link diagram formed by joining the n points at the top of T to those at the bottom without further crossings. For an m -braid b ($m \geq n$), the n -closure of b is the n -tangle formed by joining the i -th point ($n+1 \leq i \leq m$) at the top of b to that at the bottom without further crossings (Figure 16).

Figure 16.

As in Theorem 1.1.1, we have the following.

Theorem 6.1.2. Every n-tangle is isotopic to the n-closure of a braid.

For two n-tangles T and S , we define the composite tangle TS by connecting the points at the bottom of T to those at the top of S as in Figure 17. The set R_n together with the above composition law is a semigroup called the n-tangle semigroup. An n-braid is an n-tangle and we regard B_n as a subsemigroup of R_n . Let CR_n denote the semigroup algebra of R_n called the n-tangle algebra.

Figure 17.

Definition 6.1.3. For a positive integer r , the r-parallel version $T^{(r)}$ of an n-tangle T is obtained by replacing each crossings of T as in Figure 1.

Proposition 6.1.4. Let T and S be n-tangles. Their r-parallel versions $T^{(r)}$ and $S^{(r)}$ are isotopic if T and S are isotopic.

This proposition is proved by an argument analogous to the proof of Theorem 1.2.2. We use the Reidemeister moves instead of the relations in Definition 1.1.2.

Let $\phi_n^{(r)}: CR_n \rightarrow CR_{rn}$ be the algebra homomorphism defined by $\phi_n^{(r)}(T) = T^{(r)}$. Let $\iota_k^-: B_r \rightarrow CB_{rn}$ be the composition of ι_k defined by (1.4.2) and the natural inclusion $B_{rn} \rightarrow CR_{rn}$. Let $\theta: R_n \rightarrow S_n$ be the mapping such that, for $T \in R_n$, the i -th point at the top of T is joined to the $\theta(T)(i)$ -th point at the bottom by a curve of T . Then θ is a semigroup homomorphism.

Lemma 6.1.5. For $T \in R_n$ and $b \in B_r$.

$$\phi_n^{(r)}(T) \iota_k^{-}(b') = \iota_{\theta(T)(k)}^{-}(b') \phi_n^{(r)}(T) \quad (1 \leq k \leq n).$$

Proof. Let $(b, m) \in B$ such that the n -closure of b is isotopic to T . Then $\phi_n^{(r)}(T)$ is isotopic to the rn -closures of $\phi_m^{(r)}(b)$. Hence the statement of the lemma follows from Lemma 1.4.3 and the fact that the rn -closures of $(\phi_m^{(r)}(b) \iota_k(c))$ and $(\iota_k(c) \phi_m^{(r)}(b))$ are isotopic for $c \in B_r$ if $n+1 \leq k \leq m$. \square

In the following of this section let X be the one-variable Jones polynomial (respectively two-variable Jones polynomial, respectively the Kauffman polynomial). We fix the complex parameters of the invariant X so that X is of trace type and the corresponding coefficients $a_{n,i}(V)$ in (4.1.9) (respectively $a_\lambda(P)$ in Theorem 3.4, respectively $a_{i,\mu}(F)$ in Theorem 5.1.5) are all non-zero. Let X_n be the linear function on the associated algebra $A_n(X)$ defined by $X((b, n)^\wedge) = X_n(p_n(b))$ for $b \in B_n$. Then from the defining relation of these invariants, we have the following.

Proposition 6.1.6. There is an algebra homomorphism $\Xi_n: CR_n \rightarrow A_n(X)$ such that $X(T^\wedge) = X_n(\Xi_n(T))$ for $T \in R_n$.

Proof. We prove this in the case when X is the Kauffman polynomial $F(\cdot)(a, x)$. The proofs for one and two-variable Jones polynomials are similar. Let C_m ($m \in \mathbb{N}$) be the associated algebras of the Kauffman polynomial (Section 5.1). Let $F_m: C_m \rightarrow \mathbb{C}$ be the mapping defined by $F_m(p_m(b)) = F(b^\wedge)$ for $b \in B_m$. We first define a linear mapping $\Phi_m: C_m \rightarrow C_{m-1}$. Let $(\cdot, \cdot)_m$ be the symmetric bilinear form on C_m defined by using $F_m: C_m \rightarrow \mathbb{C}$ as follows:

$$(6.1.7) \quad (y_1, y_2)_m = F_m(y_1 y_2) \quad \text{for } y_1, y_2 \in C_m.$$

Since (\cdot, \cdot) is non-degenerate by the assumption of the parameters (a, x) of F , we can uniquely define Φ_m so that Φ_m satisfies $(y_1, \Phi_m(y_2))_{m-1} = (y_1, y_2)_m$ for all $y_1 \in C_{m-1}$ and $y_2 \in C_m$. By putting $y_1 = 1$, we have $F_m(y_2) = F_{m-1}(\Phi_m(y_2))$. By using the defining relations (5.1.1) of C_m , any element $y \in C_m$ can be written as $y = z_1 + z_2 \epsilon_{m-1} z_3 + z_4 \tau_{m-1} z_5$ for some $z_1, \dots, z_5 \in C_{m-1}$. By using Definition 1.1.10, we know that $\Phi_m(y) = (1 - (a - a^{-1})/x) y_1 + y_2 z_2 + a y_3 z_3$. Let $\lambda_r : C_m \rightarrow C_{m+r}$ and $\lambda_r' : B_m \rightarrow B_{m+r}$ be the algebra homomorphisms defined by $\lambda_r(\epsilon_i) = \epsilon_{i+r}$, $\lambda_r(\tau_i^{\pm 1}) = \tau_{i+r}^{\pm 1}$ and $\lambda_r'(\sigma_i^{\pm 1}) = \sigma_{i+r}^{\pm 1}$ respectively. Then

$$(6.1.8) \quad \Phi_{m+r}(\lambda_r(y)) = \lambda_r(\Phi_m(y)) \quad \text{for } y \in C_m$$

and

$$(6.1.9) \quad p_{m+r}(\lambda_r'(b)) = \lambda_r(p_m(b)) \quad \text{for } b \in B_m.$$

Hence we have

$$(6.1.10) \quad \Phi_m(y_1 y_2) = \Phi_m(y_1) y_2 \quad \text{for } y_1 \in C_m \text{ and } y_2 \in C_{m-1},$$

where $p_m : CB_m \rightarrow C_m$ is the projection defined in Section 5.1. Let T be an n -tangle. Then there is $(b, m) \in B$ whose n -closure is isotopic to T . Let

$$(6.1.11) \quad \Xi_n(T) = \Phi_{n+1}(\dots(\Phi_{m-1}(\Phi_m(p_m(b))))\dots),$$

From now on we prove that $\Xi_n(TS) = \Xi_n(T)\Xi_n(S)$ for two n -tangles T and S . Let $(b, m), (b', m') \in B$ whose n -closures are isotopic to T and S respectively. Then the product tangle TS is isotopic to the n -closure of $(\delta^{-1}\lambda_{m'-n}(b)\delta b', m+m'-n)$ where $\delta = \sigma(m'-n, 1, m'-1, n)$ (see (4.4.17)). By using (6.1.8)-(6.1.11), for $y \in C_n$, we have

$$\begin{aligned}
& F_n(y \Xi_n(TS)) \\
&= F_n(y \Phi_{n+1}(\dots(\Phi_{m+m'-n}(p_{m+m'-n}(\delta^{-1}\lambda'_{m'-n}(b)\delta b')))\dots)) \\
&= F_n(y \Phi_{n+1}(\dots(\Phi_m(\delta^{-1}\Phi_{m'+1}(\dots(\Phi_{m+m'-n}(p_{m+m'-n}(\lambda'_{m'-n}(b))))\dots)\delta p_m(b'))\dots)) \\
&= F_n(y \Phi_{n+1}(\dots(\Phi_m(\delta^{-1}\lambda_{m'-n}(\Phi_{n+1}(\dots(\Phi_m(p_m(b))))\dots)\delta p_m(b'))\dots)) \\
&= F_n(y \Phi_{n+1}(\dots(\Phi_m(\Phi_{n+1}(\dots(\Phi_m(p_m(b))))\dots)p_m(b'))\dots)) \\
&= F_n(y \Phi_{n+1}(\dots(\Phi_m(\Phi_{n+1}(\dots(\Phi_m(p_m(b))))\dots)\Phi_{n+1}(\dots(\Phi_m(p_m(b'))\dots))\dots)) \\
&= F_n(y \Xi_n(T)\Xi_n(S)).
\end{aligned}$$

Hence we get $\Xi_n(TS) = \Xi_n(T)\Xi_n(S)$. \square

For $\mu \in A_{rn}(X)^\wedge$ (respectively $\nu \in A_r(X)^\wedge$), let (ρ_μ, V_μ) (respectively (ρ_ν, V_ν)) be the corresponding representation of $A_{rn}(X)$ (respectively $A_r(X)$) and χ_μ (respectively χ_ν) its character. We regard B_r^n as a subgroup of B_{rn} as in Section 1.4. Then V_μ can be regarded as a B_r^n -module. For $\nu \in A_r(X)^\wedge$, let $V_{\mu, \nu, \dots, \nu}$ be the $(\rho_\nu \circ p_r)^{\otimes n}$ -isotypic subspace of V_μ . Then $V_{\mu, \nu, \dots, \nu}$ is invariant relative to the action of $\phi_n^{(r)}(R_n)$. Let $(\rho_{\mu, \nu}, V_{\mu, \nu, \dots, \nu})$ denote the representation $\rho_\mu \circ \Xi_{rn} \circ \phi_n^{(r)}|_{V_{\mu, \nu}}$ of R_{rn} . From Proposition 1.3.4, we know that there is a representation $\pi_{\mu, \nu}$ of R_n such that $\rho_{\mu, \nu} \cong (\rho_\nu^{\otimes n})^- \otimes \pi_{\mu, \nu}$, where $(\rho_\nu^{\otimes n})^-$ is the representation of $B_r^n \times R_n$ coming from $\rho_\nu^{\otimes n}$ as in Proposition 1.3.4. Let $\omega_{\mu, \nu}$ be the character of $\pi_{\mu, \nu}$. Then the argument proving Theorem 1.4.10 implies the next one.

Theorem 6.1.12. Let T be an n -tangle whose closure is a knot. Then we have the following.

$$(i) \quad \chi_\mu(\Xi_{rn}(\phi_n^{(r)}(T))) = \sum_{\nu \in A_r(X)} \chi_\nu(1) \omega_{\mu, \nu}(T),$$

$$(ii) \quad X^{(r)}(T^\wedge) = \sum_{\mu \in A_{rn}(X)} \left(\sum_{\nu \in A_r(X)} a_\mu(X) \chi_\nu(1) \omega_{\mu, \nu}(T) \right).$$

6.2. Mutation.

In this section, let X be the one-variable Jones polynomial V (respectively the two-variable Jones polynomial P , respectively the Kauffman polynomial F).

Definition 6.2.1. For T in the n -tangle algebra R_n , we define three non-trivial involutions γ_1 , γ_2 and γ_3 (see Figure 18). Let γ_1 be the involution defined by $\gamma_1 T = g T g^{-1}$ where $g = \sigma(1, n) \sigma(1, n-2) \dots \sigma(1, 1)$ and $\sigma(i, j) = \sigma_i \sigma_{i+1} \dots \sigma_j$ ($i < j$). Let D_T be a rectangular diagram of T and H the half-turn of D_T about the center of D_T . Put $T' = H(D_T)$. Let $\gamma_2 T$ be the element of R_n which is the isotopy class of the tangle obtained by inverting the orientations of all the strings of T' . Let γ_3 denote the composition of γ_1 and γ_2 .

Figure 18.

The involution γ_1 induces an automorphism of the 2-tangle algebra CR_2 , and γ_2 and γ_3 induce anti-automorphisms of CR_2 . Hence they induce (anti-)automorphisms of the subalgebra $E_{rn}^{(r)}(CR_n)$ of $A_{rn}(X)$, where $E_{rn}: CR_{rn} \rightarrow A_{rn}(X)$ is the algebra homomorphism introduced in Proposition 6.1.6.

Proposition 6.2.2. Let $\mu \in A_{rn}(X)^\wedge$ and $\nu \in A_r(X)^\wedge$. If the degree (i.e. the dimension of the representation space) of the representation $\pi_{\mu, \nu}$ (introduced at the end of the last section) is equal to zero or one, then we have

$$\pi_{\mu, \nu}(T) = \pi_{\mu, \nu}(\gamma_i T) \quad \text{for } T \in R_n, \quad 1 \leq i \leq 3.$$

Proof. Lemma 6.2.9, which will be given at the end of this section, shows that the actions of γ_i ($1 \leq i \leq 3$) induce \mathbb{C} -algebra (anti-)automorphisms of $\pi_{\mu, \nu}(\mathbb{C}R_2)$. But $\pi_{\mu, \nu}(\mathbb{C}R_2)$ is isomorphic to \mathbb{C} or $\{0\}$ by the assumption. Hence their actions must be trivial ones. \square

Definition 6.2.3 (see, e.g. [8]). Two links K and K' are called mutant if there are two 2-tangles T, S and an involution γ_i ($i=1, 2$ or 3) of S such that K and K' are equivalent to TS^\wedge and $(T\gamma_i S)^\wedge$ respectively.

The following theorem is the main result of this section.

Theorem 6.2.4. Let K and K' be mutant knots. Then, for a positive integer r and $\nu \in A_r(X)^\wedge$, $X^{(r, \nu)}(K) = X^{(r, \nu)}(K')$ if the degrees of the representations $\pi_{\mu, \nu}$ ($\mu \in A_{2r}(X)$) are all equal to zero or one.

Proof. Let T and S be the tangles and γ an involution of S such that K and K' are equivalent to TS^\wedge and $(T\gamma S)^\wedge$ respectively. Theorem 6.1.9 implies that

$$X^{(r, \nu)}(K) = \chi_\nu(1) \sum_{\mu \in A_{2r}(X)} a_\mu(X) \text{trace} \left(\pi_{\mu, \nu}(T) \pi_{\mu, \nu}(S) \right),$$

$$X^{(r, \nu)}(K') = \chi_\nu(1) \sum_{\mu \in A_{2r}(X)} a_\mu(X) \text{trace} \left(\pi_{\mu, \nu}(T) \pi_{\mu, \nu}(\gamma S) \right).$$

Hence the statement of the theorem follows from Proposition 6.2.2. \square

Corollary 6.2.5. Let K and K' be mutant knots. Then we have

- (i) $v^{(r,v)}(K) = v^{(r,v)}(K')$,
- (ii) ([23], [25]) $v^{(r)}(K) = v^{(r)}(K')$,
- (iii) $p^{(r,\mu)}(K) = p^{(r,\mu)}(K')$ if the partition μ of r is equal to (r) or (1^r) ,
- (iv) ([23]) $p^{(2)}(K) = p^{(2)}(K')$,
- (v) ([23]) $F^{(2)}(K) = F^{(2)}(K')$.

Proof. Recall that the degree of $\pi_{\mu,v}$ is equal to the multiplicities of $\rho_v^{\otimes 2}$ in ρ_μ for $\mu \in A_{2r}(X)^\wedge$ and $v \in A_r(X)$. By Remark 3.8, the above multiplicities may be calculated by the Littlewood-Richardson rule in the case that X is the Jones polynomial V or the two-variable Jones polynomial P . This rule shows that the degree of the representations $\pi_{\mu,v}$ for the case (i)-(iv) are all equal to 1 or 0. To prove (v), we show that the degree of $\pi_{\mu,v}$ is equal to 1 or 0 for $\mu \in A_4(F)^\wedge$ and $v \in A_2(F)^\wedge$. This can be checked by using the realizations of irreducible representations of $A_4(F)$ given in [2]. \square

Theorem 6.2.6. Let K and K' be mutant knots, i.e. there are tangles T and S and an involution γ of S such that K and K' are equivalent to TS^\wedge and $(T\gamma S)^\wedge$. Put $\lambda_0 = (321) \in \Lambda(6)$ and $\nu_0 = (21) \in \Lambda(3)$. Then, with the notations in Theorem 6.1.12 we have $P^{(3)}(K) = P^{(3)}(K')$ iff $a_{\lambda_0}(P) = 0$ and $\omega_{\lambda_0, \nu_0}(TS) = \omega_{\lambda_0, \nu_0}(T\gamma S)$.

Proof. From Theorem 1.5.1 and Corollary 6.2.5 we have $P^{(3)}(K) \neq P^{(3)}(K')$ iff $P^{(3, \nu_0)}(K) \neq P^{(3, \nu_0)}(K')$. But from Littlewood-Richardson rule (Remark 3.8), the degree of π_{λ_0, ν_0} is equal to 2 and those of π_{λ, ν_0} are equal to 1 or 0 if $\lambda \neq \lambda_0$. Hence Proposition 6.2.2 implies the statement of the theorem. \square

Example 6.2.7. We give four mutant knots K_1, K_2, K_3 and K_4 for which the invariants $P^{(3)}(K_i)$ ($1 \leq i \leq 4$) are all distinct. Let S_1, S_2, σ and σ^{-} be the tangles as in Figure 19, $S_3 = S_1 \sigma S_2$, $S_4 = S_1 S_2$ and $K_i = (S_3 \gamma_i(S_4))^\wedge$ ($1 \leq i \leq 4$, Figure 19).

Figure 19.

Let q be an indeterminate and H_6^\bullet the $Z[q^{1/2}, q^{-1/2}]$ -algebra with unit defined by the relations (3.2). Let $\Phi_m: H_m^\bullet \rightarrow H_{m-1}^\bullet$ be the mapping defined as in the proof of Proposition 6.1.6. Then, from the definition of the two-variable Jones polynomial, we know that the image $\Phi_m(H_m^\bullet)$ is contained in $H_{m-1}^\bullet \otimes_Z Z[\alpha, \alpha^{-1}, (\alpha q^{1/2} - \alpha^{-1} q^{-1/2})^{-1}]$. Hence $\Xi_n(R_n)$ ($n = 3, 6$) are contained in $H_n^\bullet \otimes_Z Z[\alpha, \alpha^{-1}, (\alpha q^{1/2} - \alpha^{-1} q^{-1/2})^{-1}]$ by (6.1.11). On the other hand, Naruse and Gyoja constructed W -graphs [18] of all the irreducible representations of H_6 (Figure 8). This means that, for each irreducible representation, they give a basis of the representation space and representation matrices of generators of H_6 with respect to the basis. The entries of the above representation matrices of the generators $T_i \in H_6^\bullet$ ($1 \leq i \leq 5$) are all contained in $Z[q^{1/2}, q^{-1/2}]$. This implies the following two facts. Let $\mathfrak{R}_6 = Z[q^{1/2}, q^{-1/2}, \alpha, \alpha^{-1}, (\alpha q^{1/2} - \alpha^{-1} q^{-1/2})^{-1}]$. The first fact is that the composition of Ξ_6 and the above representations of H_6^\bullet define

irreducible representations of R_6 defined over \mathbb{R} . The second fact is that the v_0 -isotypic subspace V_{λ_0, v_0} of the representation space V_{λ_0} of ρ_{λ_0} is defined over \mathbb{R} . Hence we can define the reduction modulo p of the representation π_{λ_0, v_0} of R_2 . This is defined over $F_p[q^{1/2}, q^{-1/2}, \alpha, \alpha^{-1}, (\alpha q^{1/2} - \alpha^{-1} q^{-1/2})^{-1}]$, where F_p is the finite field of prime order p . In the following, we put $p=23$, $\alpha=1$ and $q=2$. With these parameters, we know that $\alpha q^{1/2} - \alpha^{-1} q^{-1/2} \neq 0$ and $a_{\lambda_0}(P) \neq 0 \pmod{23}$ from the explicit formula for $a_{\lambda_0}(P)$ given in [10] or [15].

Therefore we may use Theorem 6.2.7. We calculate the elements $\Xi_6(\phi_2^{(3)}(S_1))$, $\Xi_6(\phi_2^{(3)}(S_2))$, $\Xi_6(\phi_2^{(3)}(\sigma))$ and $\Xi_6(\phi_2^{(3)}(\sigma^-))$ of $(H_6 \otimes_{\mathbb{Z}} F_{23})_{\alpha=1, q=2}$ with the aid of computers (Turbo PASCAL on MS-DOS for PC-9801 (NEC) and AOS/VS PASCAL on Eclipse MV-2000DC (DG)). Their images under π_{λ_0, v_0} with respect to the explicit basis mentioned above are

$$\pi_{\lambda_0, v_0}(\phi_2^{(3)}(S_1)) = \begin{bmatrix} 9 & 1 \\ 7 & 16 \end{bmatrix}, \quad \pi_{\lambda_0, v_0}(\phi_2^{(3)}(S_2)) = \begin{bmatrix} 8 & 19 \\ 0 & 5 \end{bmatrix},$$

$$\pi_{\lambda_0, v_0}(\phi_2^{(3)}(\sigma)) = \begin{bmatrix} 0 & 19 \\ 19 & 0 \end{bmatrix}, \quad \pi_{\lambda_0, v_0}(\phi_2^{(3)}(\sigma^-)) = \begin{bmatrix} 0 & 21 \\ 21 & 0 \end{bmatrix} \pmod{23}.$$

Hence we have

$$\pi_{\lambda_0, v_0}(\phi_2^{(3)}(S_3)) = \pi_{\lambda_0, v_0}(\phi_2^{(3)}(S_1 \sigma S_2)) = \begin{bmatrix} 14 & 20 \\ 17 & 1 \end{bmatrix},$$

$$\pi_{\lambda_0, \nu_0}(\phi_2^{(3)}(S_4)) = \pi_{\lambda_0, \nu_0}(\phi_2^{(3)}(S_1 S_2)) \equiv \begin{bmatrix} 3 & 15 \\ 10 & 6 \end{bmatrix},$$

$$\pi_{\lambda_0, \nu_0}(\phi_2^{(3)}(\gamma_1 S_4)) = \pi_{\lambda_0, \nu_0}(\phi_2^{(3)}(\sigma S_1 S_2 \sigma^-)) \equiv \begin{bmatrix} 6 & 10 \\ 15 & 3 \end{bmatrix},$$

$$\pi_{\lambda_0, \nu_0}(\phi_2^{(3)}(\gamma_2 S_4)) = \pi_{\lambda_0, \nu_0}(\phi_2^{(3)}(S_2 S_1)) \equiv \begin{bmatrix} 21 & 13 \\ 12 & 11 \end{bmatrix},$$

$$\pi_{\lambda_0, \nu_0}(\phi_2^{(3)}(\gamma_3 S_4)) = \pi_{\lambda_0, \nu_0}(\phi_2^{(3)}(\sigma S_2 S_1 \sigma^-)) \equiv \begin{bmatrix} 11 & 12 \\ 13 & 21 \end{bmatrix} \pmod{23}.$$

Thus we have $\omega_{\lambda_0, \nu_0}(\phi_2^{(3)}(S_3 S_4)) \equiv 20$, $\omega_{\lambda_0, \nu_0}(\phi_2^{(3)}(S_3 \gamma_1 S_4)) \equiv 5$,
 $\omega_{\lambda_0, \nu_0}(\phi_2^{(3)}(S_3 \gamma_2 S_4)) \equiv 7$ and $\omega_{\lambda_0, \nu_0}(\phi_2^{(3)}(S_3 \gamma_3 S_4)) \equiv 18 \pmod{23}$. Hence
the invariants $P^{(3)}(K_i)$ ($1 \leq i \leq 4$) are all distinct by Theorem 6.2.6
and so any two of the knots K_1 , K_2 , K_3 and K_4 are not equivalent.

In the rest of this paper, we shall prove the remaining part of the
proof of Proposition 6.2.2.

Lemma 6.2.8. Let (ρ, U) be an irreducible representation of $A_{rn}(X)$. Then γ_i ($i=1, 2$ or 3) induces an automorphism (respectively anti-automorphism) of $\text{End}(U)$ defined by $\gamma_i(\rho(y)) = \rho(\gamma_i y)$ ($y \in A_{rn}(X)$).

Proof. 1°) The case $i=1$. For $y \in A_{rn}(X)$, we have $\gamma_1 y = p_{rn}(\phi_n^{(r)}(g)) y p_{rn}(\phi_n^{(r)}(g))^{-1}$ where $g = \sigma(1, n) \sigma(1, n-2) \dots \sigma(1, 1)$, $\sigma(i, j) = \sigma_i \sigma_{i+1} \dots \sigma_j$ ($i \leq j$) and p_{rn} be the projection $CB_{rn} \rightarrow A_{rn}(X)$. Hence γ_1 acts on $\text{End}(U)$ by $\gamma_1(\rho(y)) = \rho(p_{rn}(\phi_n^{(r)}(g))) \rho(y) \rho(p_{rn}(\phi_n^{(r)}(g)))^{-1}$.

2°) The case $\gamma = \gamma_2$. In this case, the statement of the lemma follows from 1°) and 3°) since $\gamma_2 = \gamma_1 \circ \gamma_3$.

3°) The case $\gamma = \gamma_3$. We know realizations of every irreducible representations of $A_{rn}(X)$ such that $p_{rn}(\sigma_i)$ ($1 \leq i \leq rn-1$) are represented by symmetric matrices. When $X=V$ (respectively P , respectively F), such constructions are given in [31] (respectively [31], respectively [28]). For a matrix M , let ${}^t M$ denote the transposed matrix of M . We may assume that ${}^t \rho(p_{rn}(\sigma_i)) = \rho(p_{rn}(\sigma_i))$. Since γ_3 satisfies $\gamma_3(p_{rn}(\sigma_i)) = p_{rn}(\sigma_i)$ ($1 \leq i \leq rn-1$) and $\gamma_3(hh') = \gamma_3(h')\gamma_3(h)$ for $h, h' \in A_{rn}$, we have $\gamma_3 \rho(h) = {}^t \rho(h)$ ($h \in A_{rn}(X)$). Hence γ_3 acts on $\text{End}(U)$ by the matrix transposition. \square

Lemma 6.2.9. Let $(\pi_{\mu, \nu}, W_{\mu, \nu})$ ($\mu \in A_{2r}(X)^\wedge$, $\nu \in A_r(X)^\wedge$) be the representation of CR_2 given at the end of Section 6.1. Then γ_i ($i=1, 2, 3$) induces an (anti-)automorphism of $\pi_{\mu, \nu}(CR_2)$ defined by $\gamma_i(\pi_{\mu, \nu}(y)) = \pi_{\mu, \nu}(\gamma_i y)$ ($y \in A_{2r}(X)$).

Proof. 1°) The case $\gamma = \gamma_1$. The statement of the lemma follows from $\gamma_1(\pi_{\mu, \nu}(y)) = \pi_{\mu, \nu}(g) \pi_{\mu, \nu}(y) \pi_{\mu, \nu}(g)^{-1}$ where $g = \sigma(1, n) \sigma(1, n-2) \dots \sigma(1, 1)$ and $\sigma(i, j) = \sigma_i \sigma_{i+1} \dots \sigma_j$ ($i \leq j$).

2°) The case $\gamma = \gamma_2$. In this case, the statement of the lemma follows from 1°) and 3°) since $\gamma_2 = \gamma_1 \circ \gamma_3$.

3°) The case $\gamma = \gamma_3$. Let (ρ_μ, V_μ) be the irreducible representation of $A_{rn}(X)$ parametrized by μ . We shall show that $\pi_{\mu, \nu}(\gamma_3 y) = {}^t(\pi_{\mu, \nu}(y))$ with respect to a basis of $W_{\mu, \nu}$. In this proof, we use the following fact.

Lemma 6.2.10. Let s be an indeterminate. Let $y_1(s), y_2(s) \in M_m(\mathbb{K})$ with ${}^t y_1(s) = y_2(s)$ where \mathbb{K} is the algebraic closure of $\mathbb{C}(s)$. Let $U(s)$ be a subspace of \mathbb{K}^m such that $y_1(s)U(s) \subseteq U(s)$ and ${}^t y_1(s)U(s) \subseteq U(s)$. We assume that there is a open set \mathcal{U} of \mathbb{R} (the set of real numbers) and a basis $\{u_1(s), \dots, u_m(s)\}$ of \mathbb{K}^m such that $\{u_1(s), \dots, u_k(s)\}$ is a basis of $U(s)$ which satisfy the following conditions.

- (i) The coordinates of $u_i(s)$ ($1 \leq i \leq m$) have no branch point in \mathcal{U} and they are contained in \mathbb{R} for $s \in \mathcal{U}$.
- (ii) The vectors $u_i(s)$ ($1 \leq i \leq m$) are linearly independent for $s \in \mathcal{U}$.
- (iii) The elements of the matrix of $y_1(s)$ with respect to the above basis have no branch point in \mathcal{U} .

Then there is a basis of $U(s)$ such that the transpose of the matrix of $y_1(s) \Big|_{U(s)}$ with respect to this basis is equal to the matrix of $y_2(s) \Big|_{U(s)}$.

Proof. At first, fix $s \in \mathcal{U}$. By applying the Schmidt's method to $\{u_1(s), \dots, u_m(s)\}$, we get an orthonormal basis $\{v_1(s), \dots, v_m(s)\}$ of R^m with respect to the standard bilinear form such that $\{v_1(s), \dots, v_k(s)\}$ is an orthonormal basis of $U(s)$. With respect to the basis $\{v_1(s), \dots, v_k(s)\}$, the transpose of the matrix of $y_1(s)$ is equal to $y_2(s)$. Now we discuss for general s . From the above argument, we know that $(y_1(s))_{ij} = (y_2(s))_{ji}$ ($1 \leq i, j \leq m$) for $s \in \mathcal{U}$. But the assumption of the lemma implies that the elements of the matrix of $y_1(s)$ with respect to the basis $\{v_1(s), \dots, v_k(s)\}$ are algebraic functions in s . Hence the equalities $(y_1(s))_{ij} = (y_2(s))_{ji}$ ($1 \leq i, j \leq m$) also hold when we regard s as an indeterminate. \square

Now, we return to the proof of Lemma 6.2.9. Let $(\rho_{\mu, \nu}, V_{\mu, \nu})$ and $((\rho_V^{\otimes n})^-, V_V^{\otimes n})$ be the representations of $B_r^n \times R_n$ given at the end of Section 6.1. From the definition of $\phi_n^{(r)}$, we have

$$\phi_n^{(r)}(\gamma_3 \sigma_i) = (\sigma_{ri-r+1} \sigma_{ri-r+2} \dots \sigma_{ri-1})^{-r} (\sigma_{ri+1} \sigma_{ri+2} \dots \sigma_{ri+r-1})^r \gamma_3 \phi_n^{(r)}(\sigma_i).$$

We also have $\phi_n^{(r)}(\gamma_3 y) = c_y \gamma_3 \phi_n^{(r)}(y)$ where c_y is a product of some $(\sigma_{ri+1} \sigma_{ri+2} \dots \sigma_{ri+r-1})^{\pm r}$ ($1 \leq i \leq n-1$). Note that the exponent sum of c_y is equal to zero. The elements $\rho_{\mu}((\sigma_{ri+1} \sigma_{ri+2} \dots \sigma_{ri+r-1})^{-r})$ ($1 \leq i \leq n-1$) act on $V_{\mu, \nu}$ by the same scalar $\rho_{\nu}((\sigma_1 \sigma_2 \dots \sigma_{r-1})^{-r})$ since $(\sigma_1 \sigma_2 \dots \sigma_{r-1})^{-r}$ are contained in the center of the subgroup B_r . Since the exponent sum of c_y is equal to zero, we have $\rho_{\mu, \nu}(c_y) = 1$. Recall that $V_{\mu, \nu}$ is the $\rho_V^{\otimes n}$ -isotypic subspace of V_{μ} as a CB_r^n -module and the representation $\rho_{\mu, \nu}$ of R_n is given by restricting $\rho_{\mu} \circ \Xi_{rn} \circ \phi_n^{(r)}$ to $V_{\mu, \nu}$. The constructions of the irreducible

representations of $A_k(\mathbb{X})$ ($k \in \mathbb{N}$) referred in the proof of Lemma 6.2.8 imply that V_μ , $V_{\mu,\nu}$ and $\rho_{\mu,\nu}(y)$ ($y \in R_n$) satisfy the assumption of Lemma 6.2.10 for $s = q^{1/2}$. Therefore we have $\rho_{\mu,\nu}(\gamma_3 y) = {}^t(\rho_{\mu,\nu}(y))$ ($1 \leq i \leq n-1$) with respect to some basis of $V_{\mu,\nu}$. Let $\theta: R_n \rightarrow S_n$ be the mapping defined just before Lemma 6.1.5. The representation $(\rho_\nu^{\otimes n})^{\sim}(y)$ ($y \in R_n$) gives a permutation of a basis of $V_\nu^{\otimes n}$. Hence $(\rho_\nu^{\otimes n})^{\sim}$ contains the trivial representation of R_n with positive multiplicities. This implies that $\rho_{\mu,\nu}$ contains the representation $\pi_{\mu,\nu}$ with positive multiplicities since $\rho_{\mu,\nu} = (\rho_\nu^{\otimes n})^{\sim} \otimes \pi_{\mu,\nu}$. Let $U_{\mu,\nu}$ be a R_n -invariant subspace of V_μ where the representation $\pi_{\mu,\nu}^{\bullet}$ of R_n on $U_{\mu,\nu}$ is equivalent to $\pi_{\mu,\nu}$. We identify $(\pi_{\mu,\nu}^{\bullet}, U_{\mu,\nu})$ and $(\pi_{\mu,\nu}, W_{\mu,\nu})$. As in the case of $\rho_{\mu,\nu}$, we can show that there is a basis of $W_{\mu,\nu}$ such that $\pi_{\mu,\nu}(\gamma_3 y) = {}^t(\pi_{\mu,\nu}(y))$ for $y \in \mathbb{C}R_n$. This is what we wanted to show. \square

References.

- [1] J.S. Birman: Braids, Links, and Mapping Class Groups, Annals of Math. Studies 82, Princeton, 1974.
- [2] J.S. Birman and H. Wenzl: Braids, link polynomials and a new algebra, preprint.
- [3] N. Bourbaki: Groupes et algebre de Lie, Chapt. IV, V, VI, Hermann, Paris, 1968.
- [4] G. Burde and H. Zieschang: Knots, Walter de Gruyter, 1985.
- [5] C.W. Curtis, N. Iwahori and R. Kilmoyer: Hecke algebras and characters of parabolic type of finite groups with (B,N) -pairs, I.H.E.S. Publ. Math. 40 (1972), 81-116.
- [6] C.W. Curtis and I. Reiner: Representation theory of finite groups and associative algebras, Interscience Publishers, New York 1962.
- [7] P. Freyd, D. Yetter, J. Hoste, W.B.R. Lickorish, K. Millet and A. Ocneanu: A new polynomial invariant of knots and links, Bull. Amer. Math. Soc. 12 (1985), 239-246.
- [8] C.A. Giller: A family of links and the Conway calculus, Trans. Amer. Math. Soc. 270 (1982), 75-109.
- [9] A. Gyoja: On the existence of a W -graph for an irreducible representation of a Coxeter group, Journal of Algebra 86 (1984), 422-438.
- [10] A. Gyoja: Topological invariants of links and representations of Hecke algebras II, preprint, Osaka University.
- [11] A. Gyoja and K. Uno: On the semisimplicity of Hecke algebras, preprint, Osaka University.

- [12] P.N. Hoefsmit: Representations of Hecke algebras of finite groups with BN-pairs of classical type, thesis, The University of British Columbia.
- [13] G. James and A. Kerber: The representation theory of the symmetric group, Encyclopedia of math. and its applications 16, Addison-Wesley, 1981.
- [14] V.F.R. Jones: A polynomial invariant for knots via von Neumann algebras, Bull. Amer. Math. Soc. 12 (1985), 103-111.
- [15] V.F.R. Jones: Hecke algebra representations of braid groups and link polynomials, Ann. Math. 126 (1987), 335-388.
- [16] L.H. Kauffman: State models and the Jones polynomial, Topology 26 (1987), 395-407.
- [17] L.H. Kauffman: An invariant of regular isotopy, to appear.
- [18] D. Kazhdan and G. Lusztig: Representations of Coxeter groups and Hecke algebras, Invent. Math. 53 (1979), 165-184.
- [19] A. Kerber: Representations of permutation groups I, Lecture Note in Math. 240, Springer, Berlin, 1971.
- [20] D.E. Knuth: The Art of Computer Programming (2nd ed.), Vol.1, Fundamental Algorithms, Addison-Wesley, 1973.
- [21] A. Lascoux and M.P. Schützenberger: Polynômes de Kazhdan & Lusztig pour les grassmanniennes, Young tableaux and Schur functions in algebra and geometry (Torun, 1980), pp.249-266, Asterisque, 87-88, Soc. Math. France, Paris, 1981.
- [22] W.B.R. Lickorish: A relationship between link polynomials, Math. Proc. Camb. Philos. Soc. 100 (1986), 109-112.
- [23] W.B.R. Lickorish and A.S. Lipson: Polynomials of 2-cable-like links, preprint, Cambridge University, 1986.

- [24] H.R. Morton and H.B. Short: The 2-variable polynomial of cable knots, Math. Proc. Camb. Philos. Soc., to appear.
- [25] H.R. Morton and P. Traczyk: The Jones polynomial of satellite links around mutants, preprint.
- [26] J. Murakami: The Kauffman polynomial of links and representation theory, Osaka J. Math. 24 (1987), 745-758.
- [27] J. Murakami: On the Jones invariant of parallel links and linear representations of braid groups, unpublished manuscript.
- [28] J. Murakami: The representations of Brauer's centralizer algebra and the Kauffman polynomial of links, in preparation.
- [29] J.H. Przytycki and P. Traczyk: Invariants of links of Conway type, to appear in Kobe J. Math.
- [30] D. Rolfsen: Knots and links. Publish or Perish Inc., 1976.
- [31] H. Wenzl: Representations of Hecke algebras and subfactors, Ph.D. Thesis, University of Pennsylvania.
- [32] H. Wenzl: On the structure of Brauer's centralizer algebras, preprint, University of California, Berkeley.
- [33] J.H.C. Whitehead: On doubled knots, J. London Math. Soc. 12 (1937), 63-71.
- [34] S. Yamada: On the 2-variable Jones polynomial of satellite links, Topology and Computer Science 295-300, Kinokuniya, Tokyo 1987.
- [35] S. Yamada: Some regular isotopy invariants and a link invariant operator, preprint.

Department of Mathematics, Osaka University,
 Toyonaka, Osaka 560 JAPAN

Table 1

The maximal degree of characters needed to get the r -parallel version of the Jones polynomial of the closures of n -braids.

braid index/ r	1	2	3	4	5	6	7	8	9	
3	direct method	2	9	48	297	2002	13260	90440	653752	4601610
	our method	2	3	4	5	6	7	8	9	10
4	direct method	3	28	297	3640	48450	653752	7020405	124062000	1739969550
	our method	3	6	10	14	18	22	27	32	38

Table 2

$$\nu_0 = (2)$$

$$\lambda = (6) \quad \pi_{\lambda, \nu_0}(\sigma_1) = \pi_{\lambda, \nu_0}(\sigma_2) = \alpha^2 q^2,$$

$$\lambda = (51)$$

$$\pi_{\lambda, \nu_0}(\sigma_1) = \alpha^2 \begin{pmatrix} -1 & 0 \\ q & q^2 \end{pmatrix}, \quad \pi_{\lambda, \nu_0}(\sigma_2) = \alpha^2 \begin{pmatrix} -1 & q \\ 0 & q^2 \end{pmatrix},$$

$$\lambda = (42)$$

$$\pi_{\lambda, \nu_0}(\sigma_1) = \alpha^2 \begin{pmatrix} 1/q & 0 & 0 \\ -1/\sqrt{q} & -1 & 0 \\ 1 & q\sqrt{q} & q^2 \end{pmatrix}, \quad \pi_{\lambda, \nu_0}(\sigma_2) = \alpha^2 \begin{pmatrix} q^2 & q\sqrt{q} & 1 \\ 0 & -1 & -1/\sqrt{q} \\ 0 & 0 & 1/q \end{pmatrix},$$

$$\lambda = (411)$$

$$\pi_{\lambda, \nu_0}(\sigma_1) = \pi_{\lambda, \nu_0}(\sigma_2) = -\alpha^2,$$

$$\lambda = (33)$$

$$\pi_{\lambda, \nu_0}(\sigma_1) = \pi_{\lambda, \nu_0}(\sigma_2) = -\alpha^2,$$

$$\lambda = (321)$$

$$\pi_{\lambda, \nu_0}(\sigma_1) = \alpha^2 \begin{pmatrix} 1/q & 0 \\ -1/\sqrt{q} & -1 \end{pmatrix}, \quad \pi_{\lambda, \nu_0}(\sigma_2) = \alpha^2 \begin{pmatrix} -1 & -1/\sqrt{q} \\ 0 & 1/q \end{pmatrix},$$

$$\lambda = (222)$$

$$\pi_{\lambda, \nu_0}(\sigma_1) = \pi_{\lambda, \nu_0}(\sigma_2) = \alpha^2/q,$$

$$\lambda = (3111), (2211), (21111), (111111) \quad \dim V_{\lambda, \nu_0} = 0.$$

Table 3

r = 2:

$$\pi_{(6,0),(2,0)}(\sigma_1) = t,$$

$$\pi_{(6,1),(2,0)}(\sigma_1) = \begin{pmatrix} t & 0 \\ t^2 & -t^3 \end{pmatrix},$$

$$\pi_{(6,2),(2,0)}(\sigma_1) = \begin{pmatrix} t & 0 & 0 \\ t^{3/2}(1+t) & -t^3 & 0 \\ t^3 & -t^{7/2} & t^4 \end{pmatrix},$$

$$\pi_{(6,3),(2,0)}(\sigma_1) = -t^3,$$

r = 3:

$$\pi_{(9,0),(3,0)}(\sigma_1) = -t^{3/2},$$

$$\pi_{(9,1),(3,0)}(\sigma_1) = \begin{pmatrix} -t^{3/2} & 0 \\ -t^3 & t^{9/2} \end{pmatrix},$$

$$\pi_{(9,2),(3,0)}(\sigma_1) = \begin{pmatrix} -t^{3/2} & 0 & 0 \\ -t^{5/2}(1+t) & t^{9/2} & 0 \\ -t^3 & t^{11/2} & -t^{13/2} \end{pmatrix},$$

$$\pi_{(9,3),(3,0)}(\sigma_1) = \begin{pmatrix} -t^{3/2} & 0 & 0 & 0 \\ -t^2(1+t+t^2) & t^{9/2} & 0 & 0 \\ -t^{7/2}(1+t+t^2) & t^5(1+t) & -t^{13/2} & 0 \\ -t^6 & t^{13/2} & -t^7 & t^{15/2} \end{pmatrix},$$

$$\pi_{(9,4),(3,0)}(\sigma_1) = \begin{pmatrix} t^{9/2} & 0 \\ t^{11/2} & -t^{13/2} \end{pmatrix} .$$

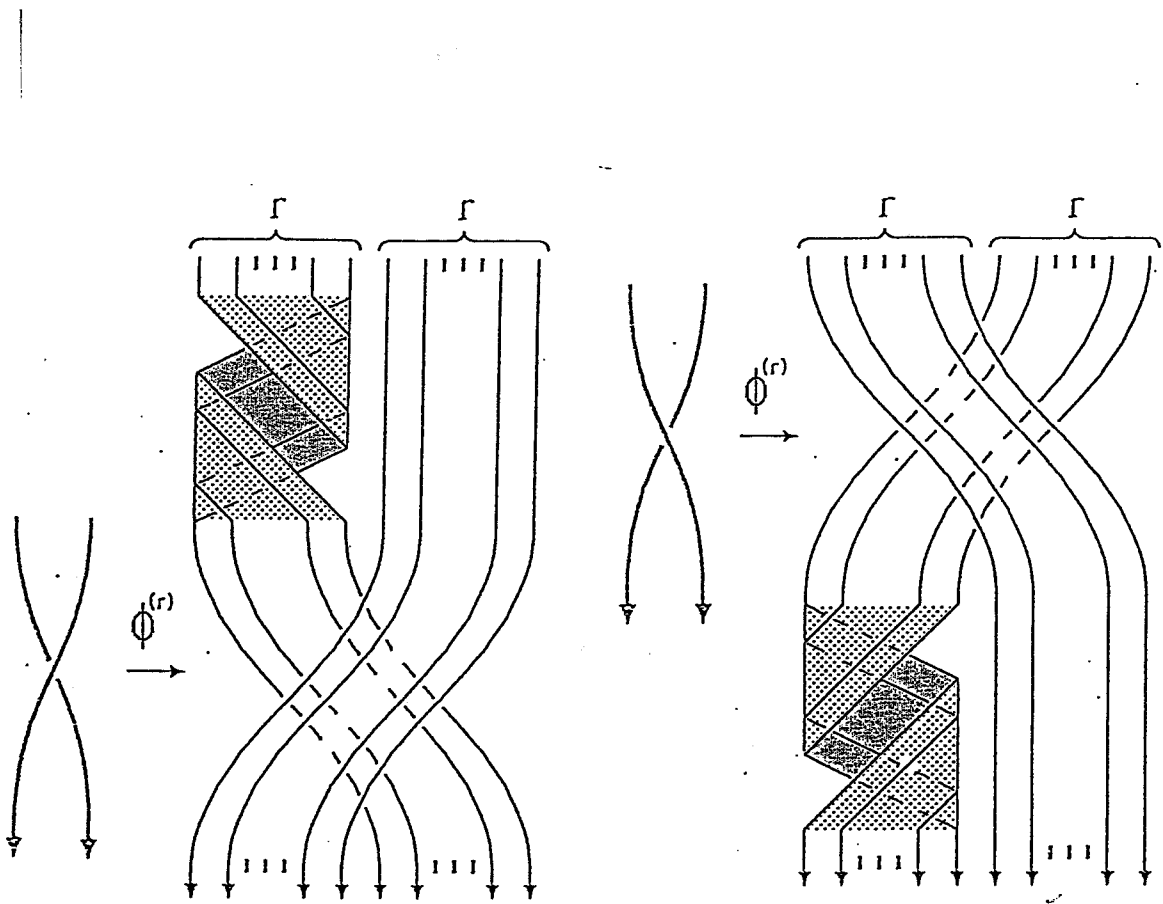

Figure 1.

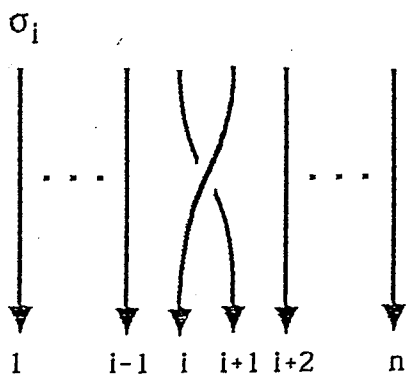

Figure 2.

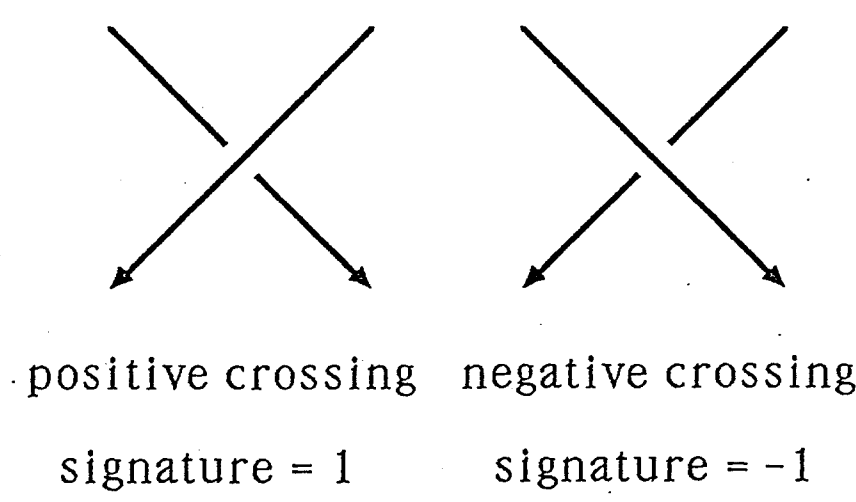

Figure 3.

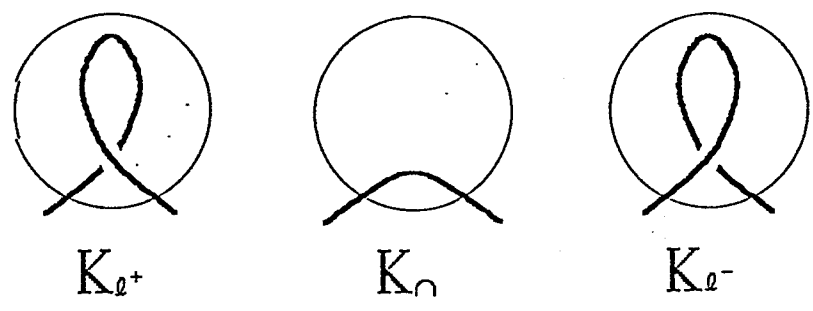
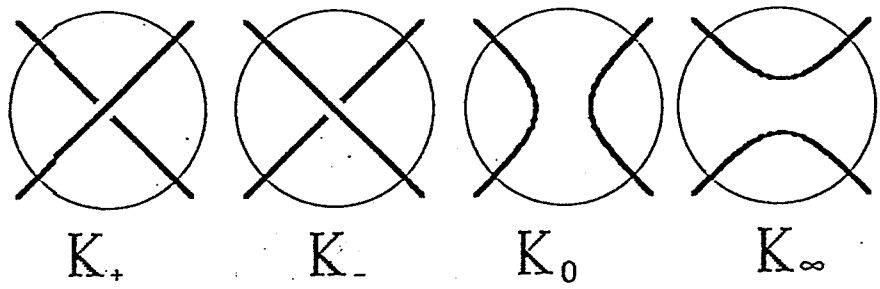

Figure 4.

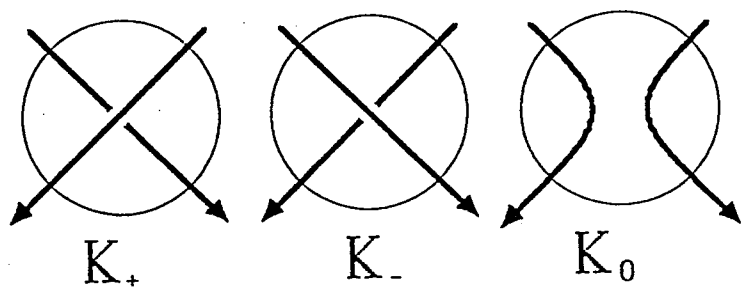

Figure 5.

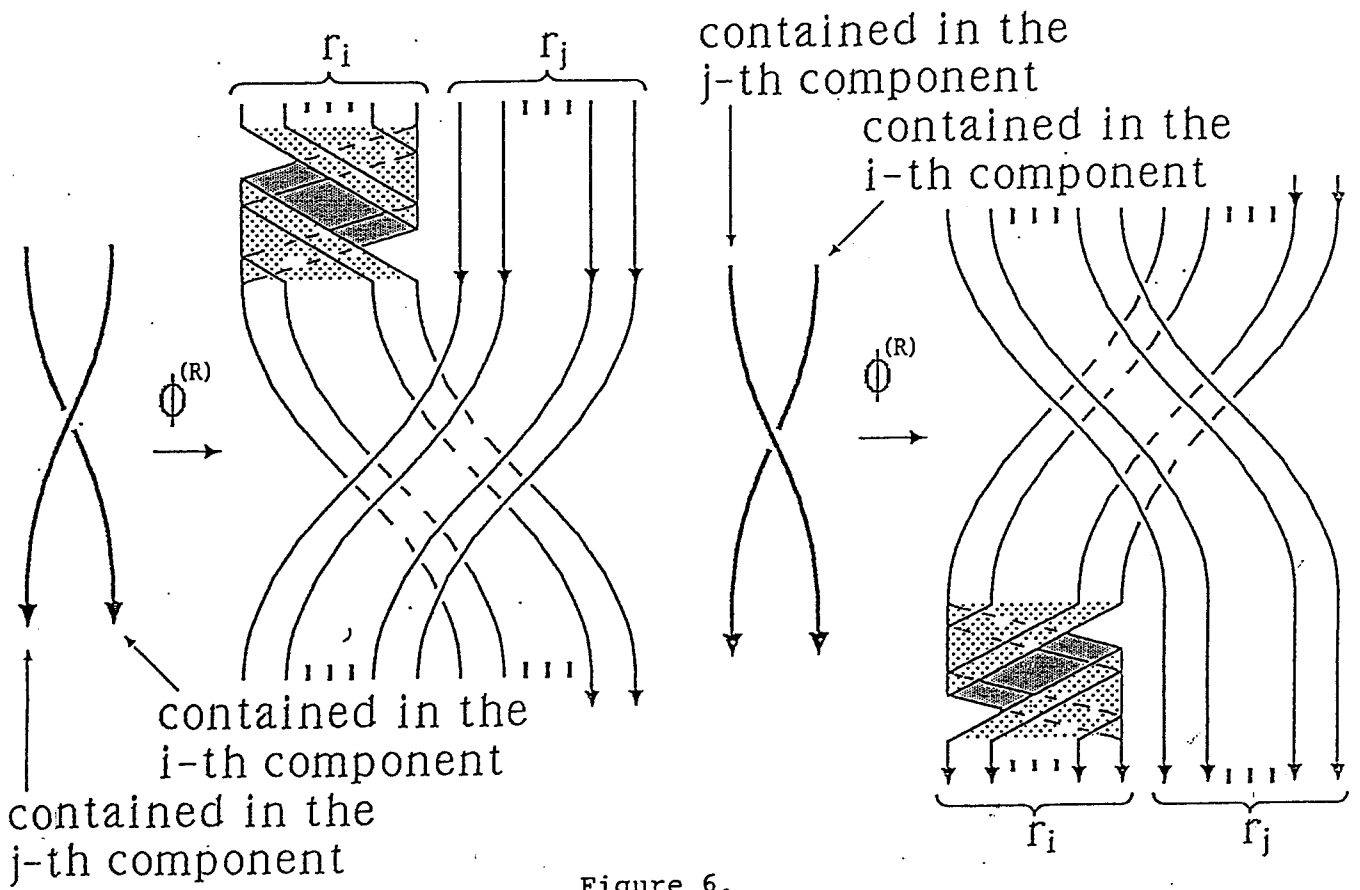

Figure 6.

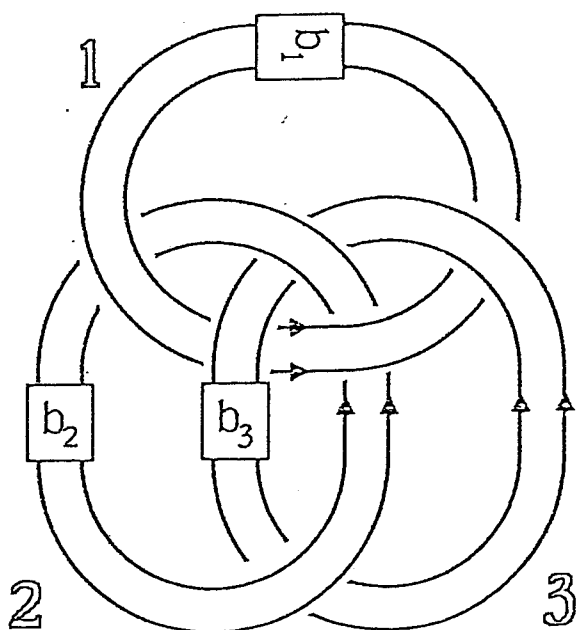
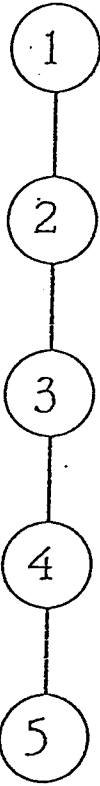

Figure 7.

$n = 6$

$\lambda = (51)$



$\lambda = (6)$



$\lambda = (33)$

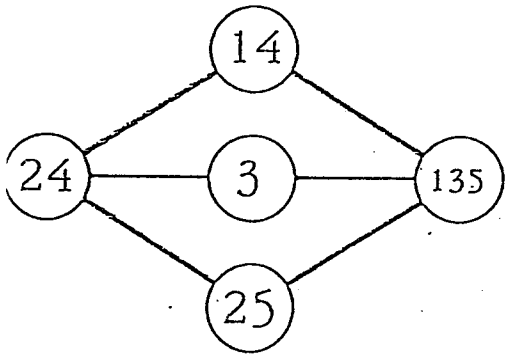

$\lambda = (411)$

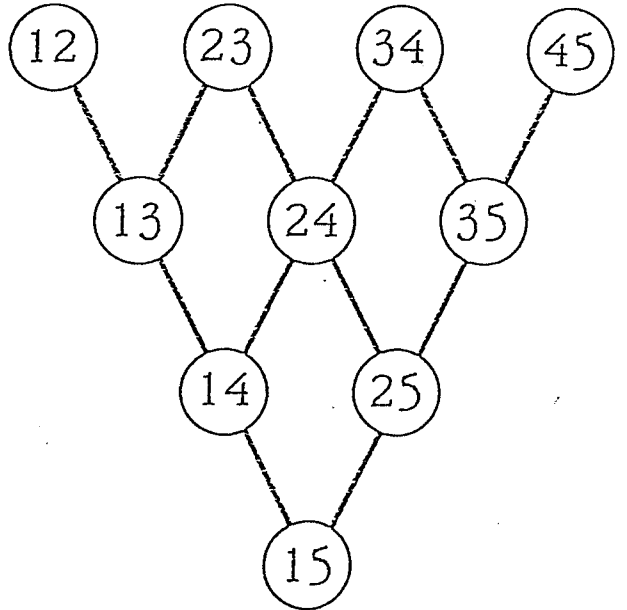

$\lambda = (42)$

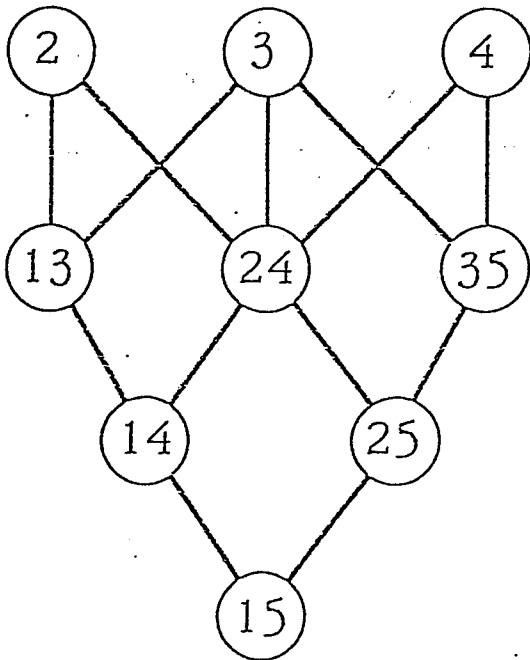

$\lambda = (321)$

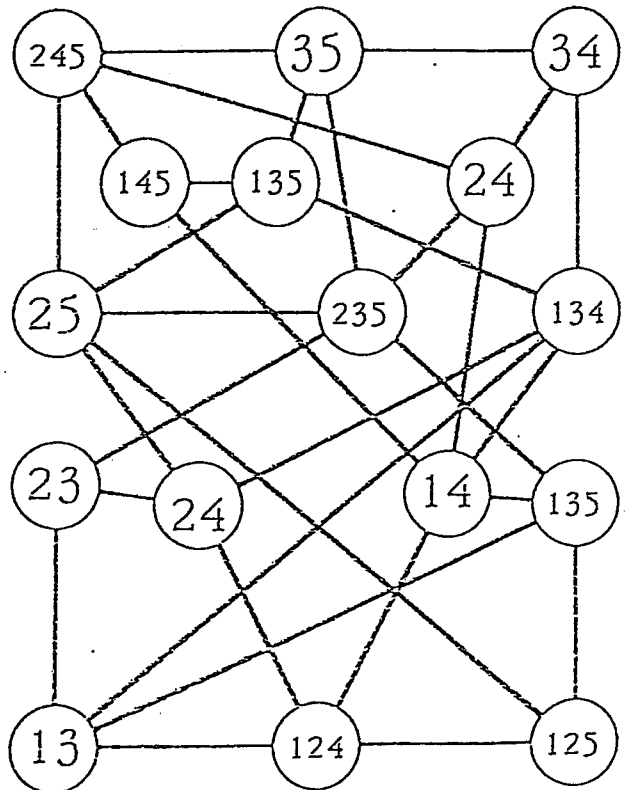

Figure 8.

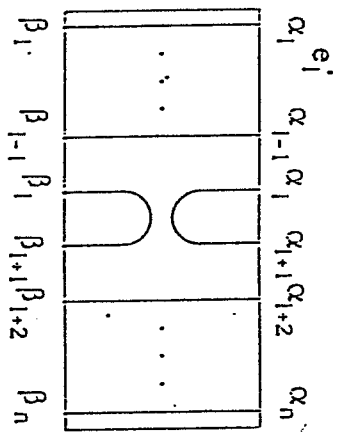

Figure 9.

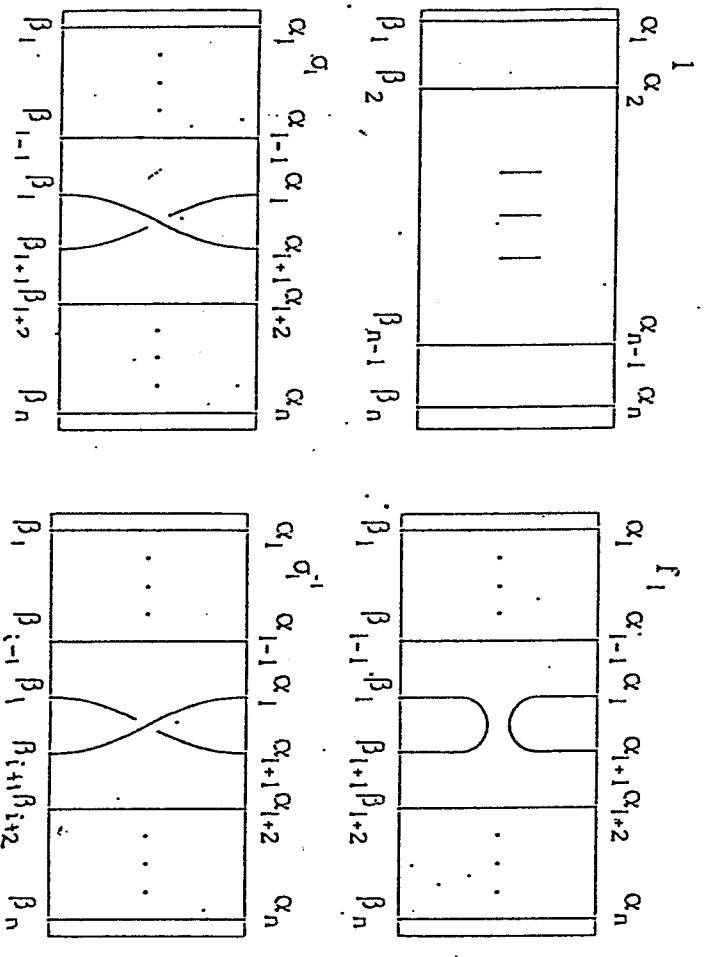
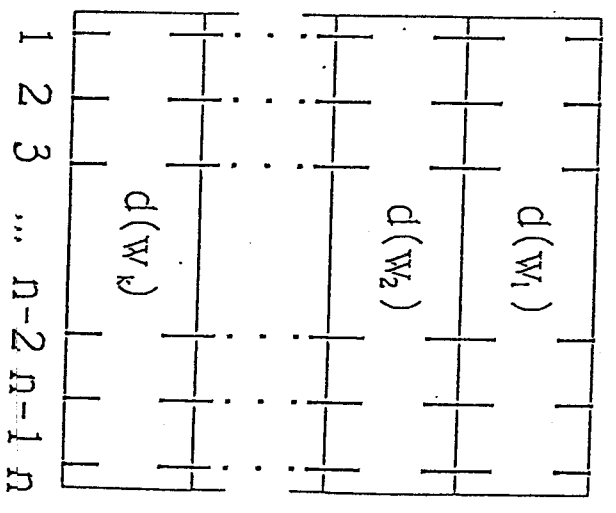

Figure 10.

$d(g, n)$

$$g = w_1 w_2 \dots w_k,$$

$$w_i \in \{1, \sigma_i, \sigma_i^{-1}, f_i \mid 1 \leq i < n-1\}$$



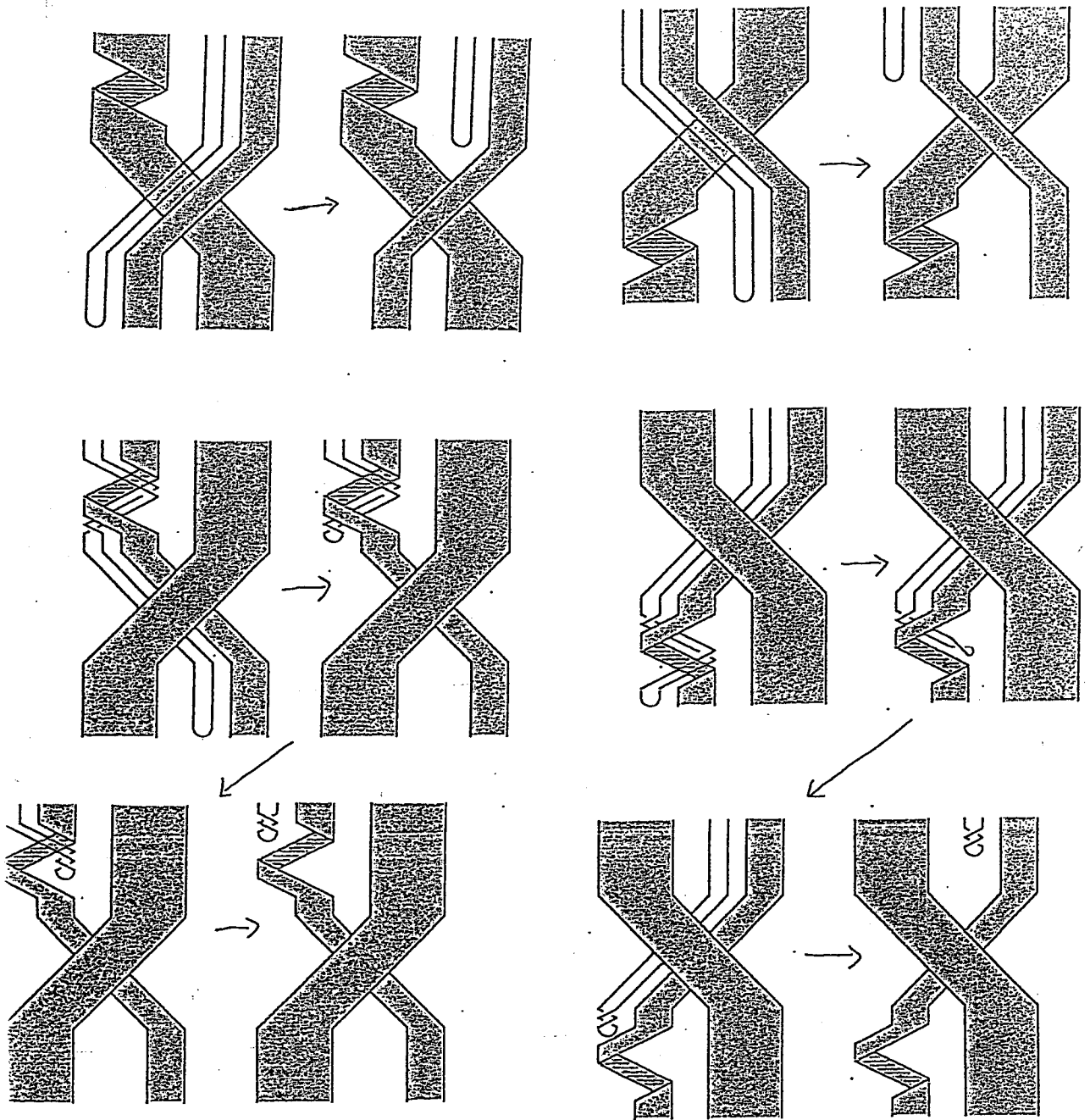

Figure 11.

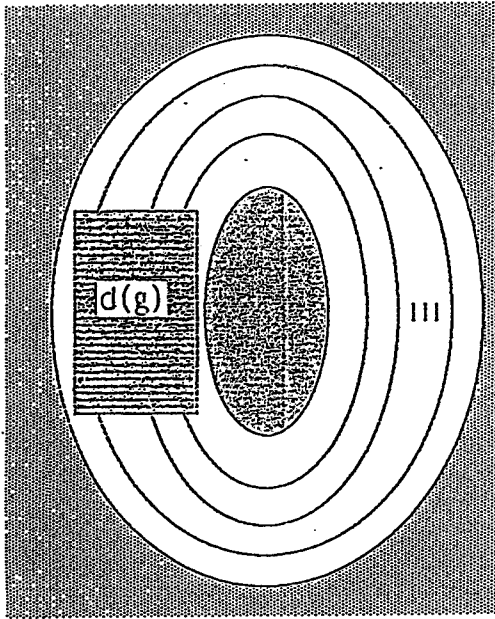

Figure 12.

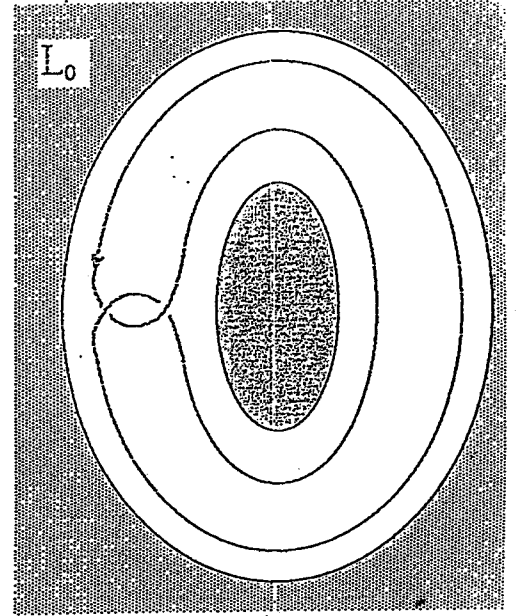

Figure 14.

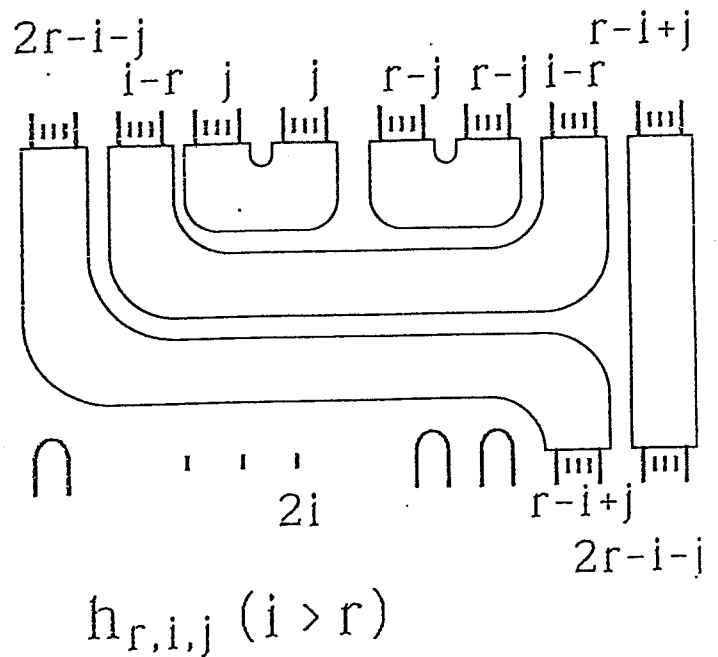
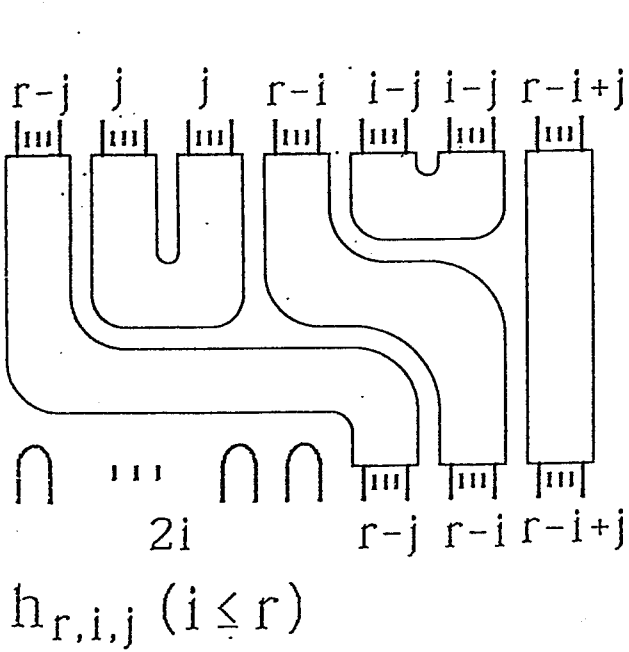

Figure 15.

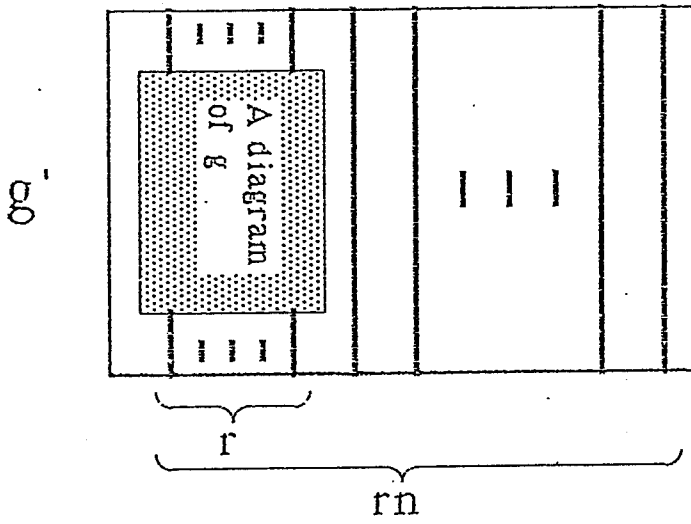

Figure 13.

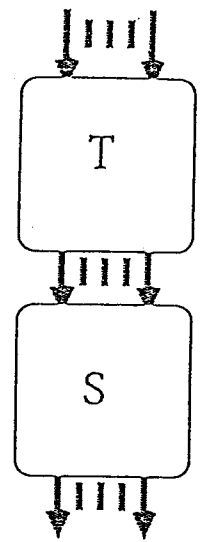
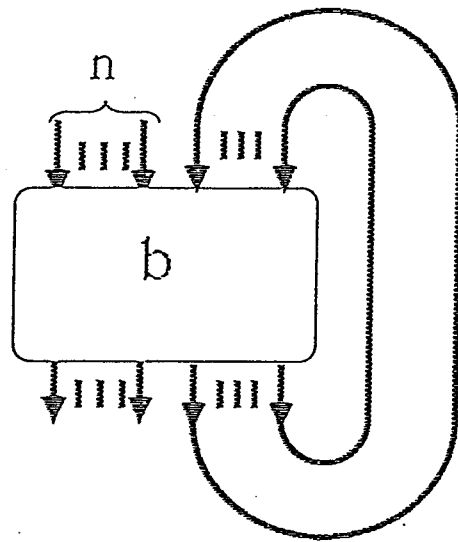
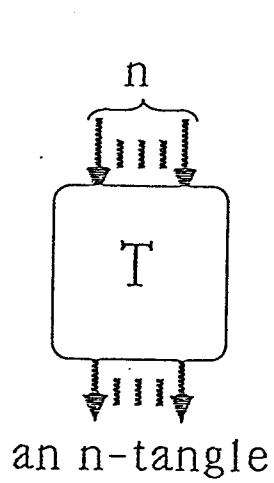
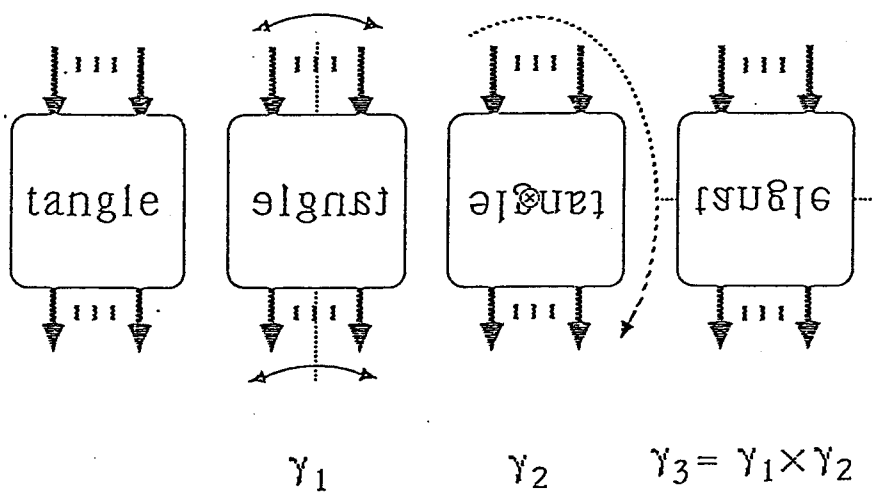

Figure 16.

Figure 17.



involutions of an n-tangle

Figure 18.

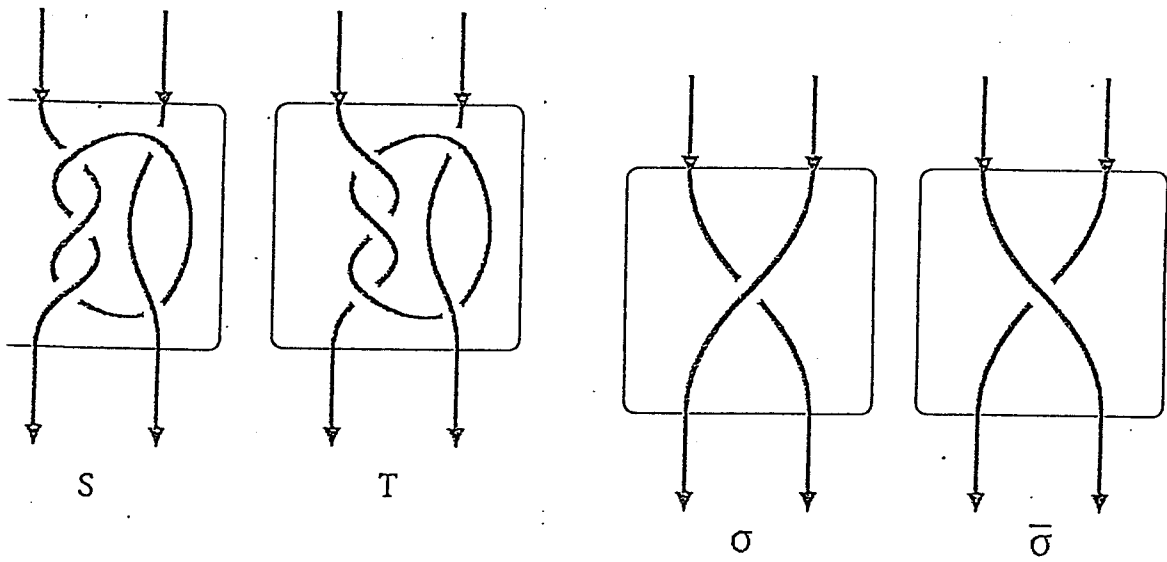

Figure 19.

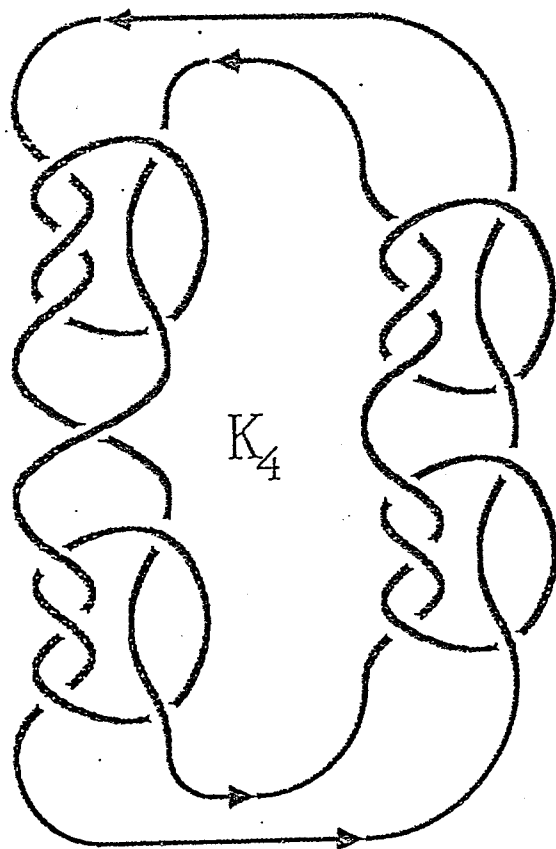
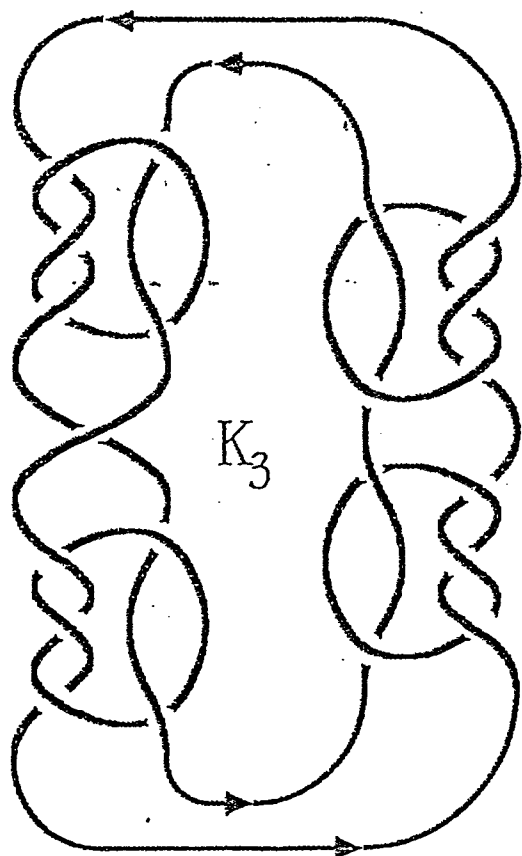
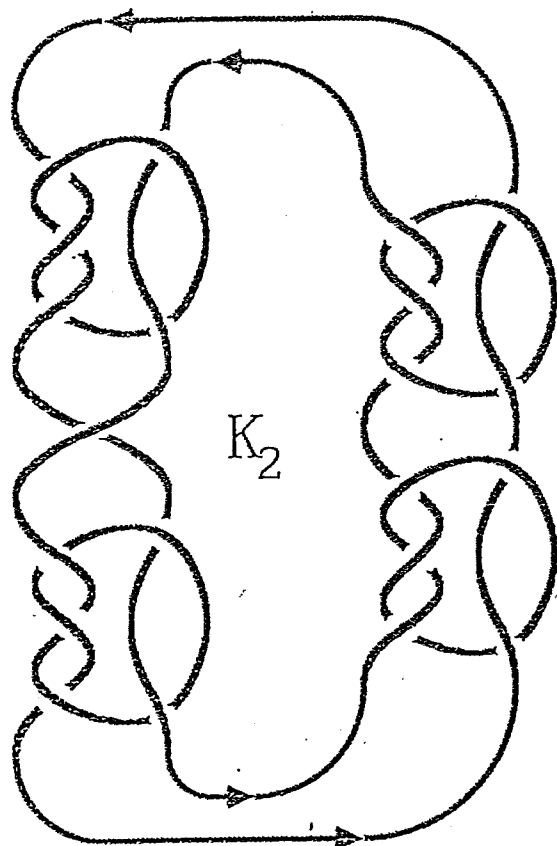
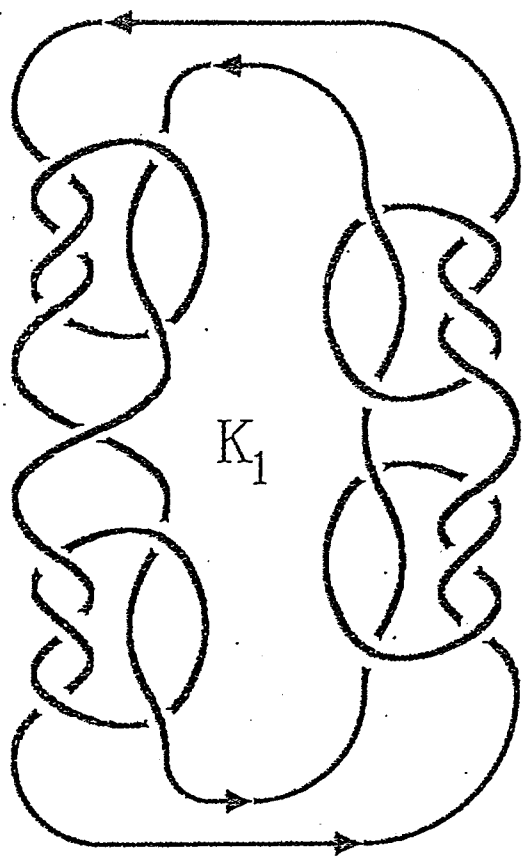

Figure 19 (Cont.)