

Title	On classification of Heegaard splittings
Author(s)	Heath, Daniel J.
Citation	Osaka Journal of Mathematics. 1997, 34(2), p. 497-523
Version Type	VoR
URL	<a href="https://doi.org/10.18910/5071">https://doi.org/10.18910/5071</a>
rights	
Note	

*Osaka University Knowledge Archive : OUKA*

<https://ir.library.osaka-u.ac.jp/>

Osaka University

## ON CLASSIFICATION OF HEEGAARD SPLITTINGS

DANIEL J. HEATH

(Received May 19, 1995)

### 1. Introduction

In [12], the Heegaard splittings of orientable Seifert fibred spaces are completely classified. The hyperbolic case, however, is left open, and even in very simple cases, very little is known about the Heegaard structure. A theorem of Moriah and Rubenstein, [11], demonstrates that the Heegaard structure of manifolds obtained by surgery on a cusped hyperbolic manifold are obtained in a natural way from the original cusped manifold's Heegaard splittings. However, this leaves the question of what those Heegaard splittings actually are wide open, as nothing is yet known about the Heegaard splittings of the cusped manifolds.

In this paper, we begin an investigation of Heegaard splittings of manifolds with either zero or one boundary component which possess an *idealized polyhedral decomposition*, or *IPD*, such as exists for cusped hyperbolic manifolds or hyperbolic manifolds with geodesic boundary, by proving the following theorem:

**Theorem 1.1.** *Let  $M$  be a manifold with a single boundary component, and  $S$  be an irreducible genus  $g$  Heegaard surface for  $M$  which is rigid with respect to an idealized polyhedral decomposition  $T$ . Then one of the compression bodies (in the Heegaard splitting) is a regular neighborhood of some subset of the 1-skeleton of  $T$ .*

The rigidity condition, together with other ideas necessary in the proof, is defined in Section 2. Section 3 is devoted to the proof of Theorem 1.1.

We note a use for this theorem in Section 4, in which we prove the following corollary:

**Corollary 1.2.** *Let  $M$  be a 3-manifold with 1 boundary component whose non-rigid (with respect to  $T$ ) Heegaard splittings are weakly reducible. Assume further that any closed incompressible 2-sided surface in  $M$  is boundary parallel. Then all Heegaard splittings of  $M$  are either induced by  $T$  as per Theorem 1.0, or are the amalgamation of such Heegaard splittings with a trivial Heegaard splitting of a collar of the boundary.*

This follows ideas of [14], in which Gabai's concept of thin position and

Casson-Gordon's concept of strong irreducibility are employed to demonstrate that all Heegaard splittings of  $(\textit{orientable surface}) \times I$  are *standard*, that is, one of two so-called trivial splittings, perhaps with extra handles attached in a trivial manner.

We will continue by considering the Heegaard splittings of manifolds possessing an IPD with only one edge. In particular, we classify Heegaard splittings of some of the more important ones, specifically twisted  $I$ -bundles and some simple hyperbolic spaces, by making use of the following theorem, which is proven in Section 5.

**Theorem 1.3.** *Let  $M$  be a manifold with a 1-edged IPD,  $T$ , and  $S$  be an irreducible Heegaard surface for  $M$  which is not (weakly) rigid with respect to the single edge  $T_1$  of  $T$ . Then  $S$  is weakly reducible.*

We continue in section 6 to the classification of incompressible surfaces for such manifolds, resulting in the following:

**Theorem 1.4.** *Let  $M$  be a manifold with a 1-edged IPD. Then any 2-sided incompressible surface in  $M$  is boundary parallel.*

We call a Heegaard splitting which is induced by  $T_1$  *trivial*. A trivial Heegaard splitting amalgamated with a trivial Heegaard splitting of a collar of the boundary we call *almost trivial*. We then combine Theorems 1.3 and 1.4 in Section 7 to prove:

**Main Theorem 1.5.** *Let  $M$  be a manifold with a 1-edged IPD. Then any irreducible Heegaard splitting of  $M$  is either trivial or almost trivial.*

This will result in the following corollary:

**Corollary 1.6.** *Let  $M$  be a twisted  $I$ -bundle. Then any irreducible Heegaard splitting of  $M$  is trivial.*

Further, in Section 8 we use the Main Theorem to classify all Heegaard splittings of some other spaces. In particular, we demonstrate that there is only one irreducible Heegaard splitting for either the Gieseking manifold or the Thurston manifold: that induced by the 1-skeleton of the "canonical" triangulation. It should be noted that this is the first such result for hyperbolic spaces.

This material is based upon work carried out during my tenure as an NSF-nominated Japan Society for the Promotion of Science postdoctoral fellow (NSF grant no. 9400660; JSPS I.D. No. P-94157).

I would like to express my thanks to the department of mathematics at Nara Women's University, where much of this was completed, for its generous hospitality. I would also like to thank Drs. Abigail Thompson and Tsuyoshi Kobayashi for

many helpful conversations.

**2. Preliminaries**

Throughout this paper we use the notation  $N(*)$  to refer to a regular neighborhood of  $*$ ,  $^{\circ}*$  to refer to the interior of  $*$ , and the notation  $\sharp(*)$  to refer to the number of components of  $*$ .

A *compression body*  $H$  is constructed by adding 2-handles to a (*closed connected surface*)  $\times I$  along a collection of disjoint simple closed curves on (*surface*)  $\times \{0\}$  whose regular neighborhoods in (*surface*)  $\times \{0\}$  are annuli, and capping off any resulting 2-sphere boundary components with 3-balls. The component (*surface*)  $\times \{1\}$  of  $\partial H$  is denoted  $\partial_+ H$  and the surface  $\partial H \setminus \partial_+ H$ , which may or may not be connected, is denoted  $\partial_- H$ . If  $\partial_- H = \emptyset$ , then  $H$  is a *handlebody*.

A *spine*,  $X$ , of a compression body  $H$  is a properly embedded 1-complex such that  $H = N(\partial_- H \cup X)$ . We note that spines are not unique, but can be altered by *edge slides*, as follows: Choose an edge  $e \in X$ , and let  $\bar{X} = X \setminus e$ . Let  $\bar{H}$  denote a regular neighborhood of  $\partial_- H \cup \bar{X}$ . Then  $H$  is the union of  $\bar{H}$  and a 1-handle  $h$  attached to  $\partial_+ \bar{H}$ . The core of  $h$  is the edge  $e$ , with its ends in  $\bar{H}$  deleted so that  $\partial e \subset \partial_+ \bar{H}$ . Suppose  $c$  is a path on  $\partial_+ \bar{H}$  which begins at one end of  $e$ . Then this end of  $e$  can be isotoped along  $c$  before  $h$  is attached. The effect on  $X$  is to replace  $e$  with the union of  $e$  and a copy of  $c$  pushed slightly away from  $X \cup \partial_- H$ , see Figure 0.

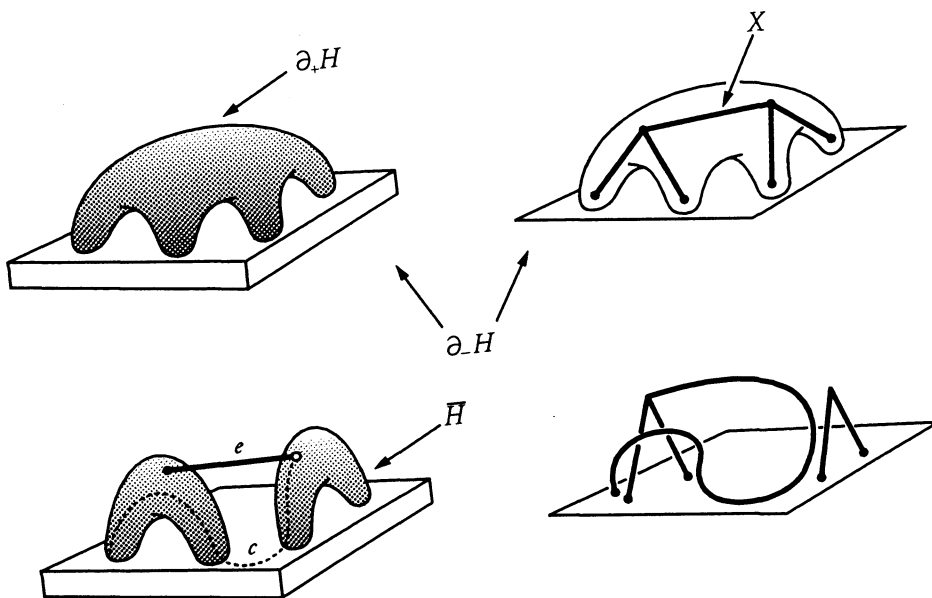

Fig. 0.

The cores of the 2-handles defining  $H$ , extending vertically down through  $\partial_+H \times I$  are called a *defining set* of 2-discs for  $H$ . The result of cutting  $H$  along a defining set of 2-discs is a copy of  $\partial_-H \times I$  union some 3-balls. Any collection of disjoint  $\partial$ -reducing discs for  $H$  can be expanded to a defining set by doing 2-surgery and then compressing the remnants of  $\partial_+H$  as much as possible.

For a compact manifold  $M$ , a 3-tuple of manifolds  $(H_0, H_1; S)$  is called a *Heegaard splitting* of  $M$  if  $H_0, H_1$  is a pair of compression bodies with the property that  $M = H_0 \cup H_1$  and  $H_0 \cap H_1 = \partial_+H_0 = \partial_+H_1 = S$ , for some closed connected surface  $S$  embedded in  $M$ . The surface  $S$  is called the *splitting surface* of the Heegaard splitting  $(H_0, H_1; S)$ , but we shall sometimes refer to either  $S$  or  $(H_0, H_1)$  as the Heegaard splitting. Two Heegaard splittings of  $M$  are considered *equivalent* if their splitting surfaces are isotopic. It should be noted that this is a very strong type of equivalence. For example, it can easily be shown that the Heegaard splittings induced by the two “tunnels” of the figure-8 knot complement are non-equivalent [2], yet they are homeomorphic by an orientation-reversing homeomorphism. We also note that for this definition,  $(H_0, H_1; S)$  is equivalent to  $(H_1, H_0; S)$ .

A closed surface  $F$  of Euler characteristic  $\chi(F) = 2 - 2g$  is said to be of genus  $g$ , whether or not  $F$  is orientable. The sphere, then, is the unique surface of genus 0, the projective plane the unique surface of genus 1/2, but there are two genus 1 surfaces: the torus and Klein bottle. A 3-manifold with minimal genus  $g$  Heegaard splitting is said to be of genus  $g$ . Let  $M$  be a compact manifold with boundary. Then we can show that the equality  $1/2\chi(\partial M) = \chi(M)$  holds by Poincaré duality. This implies that a manifold with fractional genus must have at least two boundary components.

An *elementary stabilization*  $E(H_0, H_1)$  of  $S$  is the splitting surface obtained by taking the connected sum of pairs  $(M, S) \sharp (S^3, T^2)$ , for  $T^2$  the standard unknotted torus in  $S^3$ . A *stabilization* of  $(H_0, H_1)$  is a Heegaard splitting  $E^k(H_0, H_1)$ , such that  $E^i(H_0, H_1)$  is an elementary stabilization of  $E^{i-1}(H_0, H_1)$ . A Heegaard splitting is *stabilized* if it is an elementary stabilization of another splitting. We note that this is equivalent to the existence of proper discs  $D_i \subset H_i$  such that  $\partial D_0 \cap \partial D_1 = \{\text{one point}\}$ .

Following [14], we will say that a Heegaard splitting is *reducible* if there exists an essential simple closed (two-sided) curve  $c \subset S$  which bounds imbedded discs in both  $H_0$  and  $H_1$ . A Heegaard splitting is *weakly reducible* if there exist essential discs  $D_0 \subset H_0$  and  $D_1 \subset H_1$  with  $\partial D_0 \cap \partial D_1 = \emptyset$ . Note that by [[9], 3.3] there are no non-trivial  $I$ -bundles over a disc, and as such the above discs are 2-sided, even in the nonorientable case. If  $S$  is reducible then it is clearly weakly reducible. If  $S$  is not weakly reducible, we say that it is *strongly irreducible*.

REMARK 2.1. Let  $M$  be an irreducible manifold. It is a well-known result that for Heegaard surfaces of  $M$  of genus greater than 1, “reducible” and “stabilized”

are equivalent terms.

A proof of this fact can be found in [14, 2.1].

Since all Heegaard splittings of manifolds of genus 0, 1/2, and 1 are classified by [17], [9], and [3], we shall from this point assume that any manifold in question is of genus at least 3/2, and thus that “reducible” and “stabilized” are equivalent. Note that manifolds of genus 3/2 have at least two boundary components. For this reason, we shall in this paper be ignoring these as well.

Let  $R$  be a closed surface contained in the boundary of a 3-manifold  $M$ . Let  $U_0, U_1$  be a pair of compression bodies defining a Heegaard splitting of  $M$ , and assume that  $R \subset \partial U_0$ . Note that  $R' = \partial U_0 \setminus R$ , ( $R'$  can be empty) so that  $U_0 = N(R \cup R') \cup 1$ -handles. Let  $f$  be a homeomorphism  $N(R) \rightarrow R \times I$  and  $p : R \times I \rightarrow R$  the projection onto the first factor.

Let  $M_1, M_2$  be two manifolds each with non-empty boundary and with Heegaard splittings  $(U_0, U_1), (V_0, V_1)$  respectively. Let  $R_1, R_2$  be two homeomorphic surfaces such that  $R_1 \subset \partial U_0 \subset \partial M_1$  and  $R_2 \subset \partial V_0 \subset \partial M_2$ , and let  $f_i, p_i, i = 1, 2$ , be the corresponding functions respectively.

Define an equivalence relation  $\sim$  on  $M_1 \cup M_2$  as follows:

1) If  $x_i, y_i$  are points such that  $x_i, y_i \in N(R_i)$  and  $p_i f_i(x_i) = p_i f_i(y_i)$  then  $x_i \sim y_i, i = 1, 2$ .

2) If  $x \in R_1, y \in R_2$  and  $g(x) = y$ , where  $g : R_1 \rightarrow R_2$  is the homeomorphism between the surfaces, then  $x \sim y$ .

Furthermore we can arrange the attaching discs on  $R_1 \times I (R_2 \times I)$  for the one handles in  $U_0 (V_0)$  respectively, have disjoint images in  $R_1 (R_2)$  and hence do not get identified to each other. Now set:

$$M = (M_1 \cup M_2) / \sim, H_0 = (U_0 \cup V_1) / \sim, H_1 = (U_1 \cup V_0) / \sim.$$

Note that  $H_0 = V_1 \cup N(R'_1) \cup (1$ -handles) and  $H_1 = U_1 \cup N(R'_2) \cup (1$ -handles) (The 1-handles connect  $\partial_+ V_1$  to  $\partial N(R'_1)$  ( $\partial_+ U_1$  to  $\partial N(R'_2)$ ) respectively) so that  $H_0, H_1$  are compression bodies defining a Heegaard splitting for  $M$ . This Heegaard splitting is called the *amalgamation* of the Heegaard splittings  $(U_0, U_1)$  of  $M_1$  and  $(V_0, V_1)$  of  $M_2$  along  $R_1, R_2$ . Figure 1 shows the amalgamation process.

Let  $M$  be a 3-manifold with a single boundary component of genus  $m$ , and  $(H_0, H_1; S)$  be a genus  $g$  Heegaard splitting of  $M$ , that is,  $S$  is a genus  $g$  Heegaard surface for  $M$ ,  $H_0 =$  the compression body, and  $H_1 =$  the handlebody. Choose a minimal set of defining discs for the compression bodies, so we don't need a 3-handle for  $H_0$ , and we need exactly one for  $H_1$ .

The handle description defines a Morse function  $h : M \rightarrow [0, 1]$ . The splitting surface will occur as the inverse image of a regular value of  $h$ . We arrange the singular values of  $h$ , i.e.  $0 = a_0 < a_1 < \dots < a_{g-m} < b_1 < \dots < b_g < 1$ , so that passing through a critical point labelled with an  $a_i$  corresponds to adding a

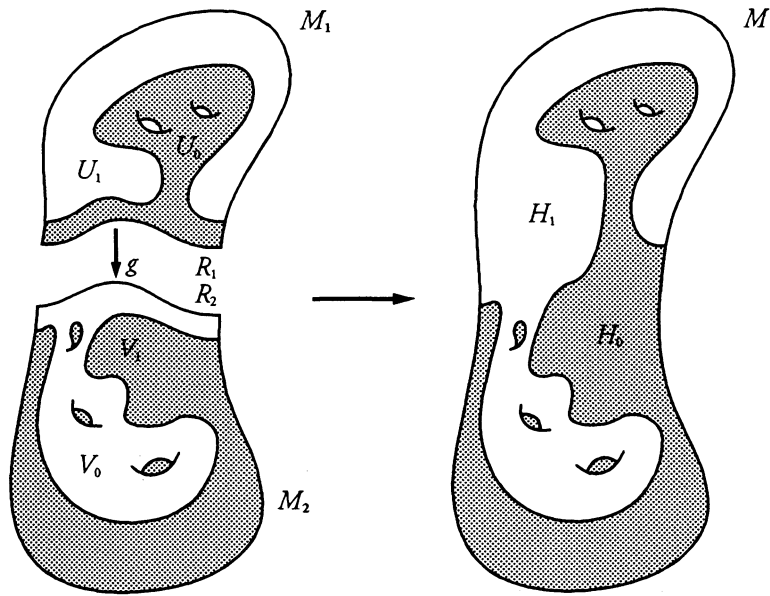

Fig. 1.

1-handle, passing a  $b_i$  corresponds to adding a 2-handle, and  $h^{-1}(c)$  is isotopic to  $S$  for  $a_{g-m} < c < b_1$ . Thus we have the following:

The leaf of the foliation corresponding to  $h^{-1}(a_0) = h^{-1}(0)$  is just  $\partial_- H_0 = \partial M =$  (a genus  $m$  surface). All leaves  $h^{-1}(r)$  are isotopic for  $a_0 < r < a_1$ , but  $h^{-1}(a_1)$  is a singular surface in which two points have been pinched together, forming a 1-handle, see Figure 2. Thus for  $a_1 < r < a_2$ ,  $h^{-1}(r)$  is a genus  $m + 1$  surface. Similarly, each of the  $h^{-1}(a_i)$  corresponds to a singular surface in which two points on the previous leaves have been pinched together, increasing the genus of the leaves in the foliation by one, so that for  $a_{g-m} < r < b_1$ ,  $h^{-1}(r)$  is a genus  $g$  surface. On the other hand,  $h^{-1}(b_1)$  is a singular level in which a circle has been pinched into a point, forming a 2-handle, and the picture is the same as in Figure 2, except turned upside down. Then for  $b_1 < r < b_2$ ,  $h^{-1}(r)$  is a genus  $g - 1$  surface. Note that  $h^{-1}(1)$  is the maximal point in  $H_1$ .

Let  $T$  be a polyhedral decomposition for  $M$  such that:

- (0)  $M \setminus (2\text{-skeleton of } T)$  is a union of balls,  $T_3^0, \dots, T_3^{n_3}$ ,
- (1)  $\partial M$  appears as a union of (punctured) discs in  $\partial T_3^k$ ,
- (2)  $(1\text{-skeleton of } T) \setminus \partial M$  is a union of open arcs,  $T_1^0, \dots, T_1^{n_1}$ ,
- (3)  $(2\text{-skeleton of } T) \setminus \partial M$  is a union of discs,  $T_2^0, \dots, T_2^{n_2}$ , such that each  $T_2^k$  is a zero gon (i.e., its boundary lies in  $\partial M$ ), a monogon (i.e., its boundary consists of some  $T_1^i$  union a part of  $\partial M$ ), a bigon, or a triangle.

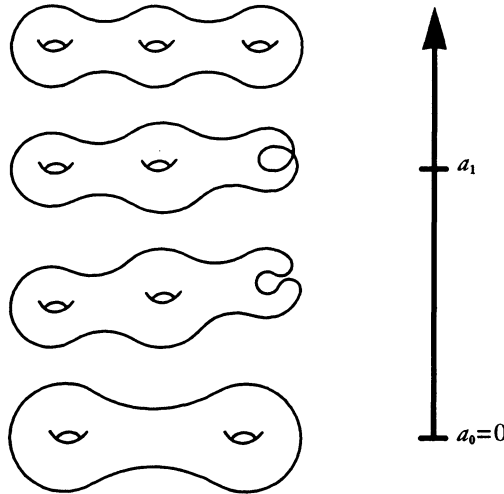

Fig. 2.

Then  $T$  is said to be an *idealized polyhedral decomposition*, or *IPD*, for  $M$ .

Note, for example, that a genus  $n$  handlebody has a natural IPD obtained by cutting along  $n$  meridional discs. Then  $\partial M$  appears as a  $2n$ -punctured sphere,  $T_2$  is a union of  $2n$  zerogons, and  $T_1$  is empty. Another example of an IPD is a truncated ideal triangulation for a cusped hyperbolic manifold. We note that an idealized polyhedral decomposition can be obtained from an ideal polyhedral decomposition of a cusped hyperbolic manifold by dividing all faces having more than 3 edges with additional edges (in order to satisfy condition (3)); note that this can be done in more than one way) and truncating the (ideal) vertices.

We note that by removing a small ball from a manifold without boundary, we may define an IPD for a closed manifold, and that all the arguments in this paper still hold.

Ignoring the faces of  $T$  which are contained in  $\partial M$ , we denote by  $T_j = \cup_{k=1}^{n_j} T_j^k$  the  $j$ -skeleton of  $T$ , that is, each  $T_3^k$  is a polyhedron,  $T_2^k$  is a zerogon, monogon, bigon, or triangle, and  $T_1^k$  is an arc. We define  $T_0$  to be  $\partial M$ , though we shall refer to  $T_0^k$  as the “vertices” of  $T$ .

If  $T_1 = \emptyset$ , i.e., each face of  $T_2$  is a zerogon, then  $M$  is clearly a handlebody, and the results of this paper follow from [14]. We thus assume that  $T_1$  is not empty.

Let  $I_1, \dots, I_n$  be the critical values of  $T_1$  (with respect to the Morse function  $h$  induced by the Heegaard splitting  $S$ ), where  $0 < I_1 < \dots < I_n < 1$ . Let  $x_i$  be



regular values of  $h|_M, h|_{T_2}$  such that  $0 < x_0 < I_1, I_n < x_n < 1$ , and  $I_i < x_i < I_{i+1}$  for  $0 < i < n$ . Then each  $h^{-1}(x_i)$  is a level surface  $S_i$ . Define the width  $w(T)$  of  $T$  to be the number of intersections of  $\cup S_i$  with  $T_1$ , that is,  $w(T) = \sum_i \#(S_i \cap T_1)$ , and isotope  $T$  so as to be of minimal width.

If each edge  $T_1^k$  in the 1-skeleton of  $T$  has exactly one critical point with respect to the Morse foliation induced by  $S$ , then  $S$  is said to be *rigid*. If each edge  $T_1^k$  has either no critical points, or if all critical points are either all maxima or all minima with respect to the Morse foliation induced by  $S$ , then  $S$  is said to be *weakly rigid*.

A Heegaard splitting is said to be *trivial with respect to  $T$*  if it is induced by a subset of  $T_1$ . In other words,  $H_0 = N(\partial M \cup X)$ , where  $X$  is some subset of  $T_1$ , or equivalently, that a spine of  $H_0$  can be moved by a finite series of ambient isotopies and edge slides so that  $X$  itself is a subset of  $T_1$ . We shall abbreviate the above as *trivial*. Note that if  $X$  is empty,  $M$  must be a compression body.

We note that Theorem 1.1 can be restated as follows:

**Theorem 1.1'.** *Let  $S$  be an irreducible genus  $g$  Heegaard surface for  $M$  which is rigid with respect to the idealized polyhedral decomposition  $T$ . Then  $S$  is trivial.*

**Proposition 2.2.** *Let  $F$  be a closed connected surface. Set  $M = F \times I$ , and let  $S$  be a Heegaard splitting for  $M$ . Then  $S$  is standard. In other words, using the above notation, there are exactly two irreducible Heegaard splittings for  $M$ :  $X = \emptyset$ , and  $X = \text{vertical arc}$ .*

**Proof.** With the exception of  $F = \mathbf{RP}^2$ , the proof is identical to that of [14], after making the appropriate definitions for the non-orientable case, such as is done above. For  $F = \mathbf{RP}^2$ , [14, 5.1] fails because the polyhedral decomposition has only two sides. But in this case it is elementary to check that the splitting is stabilized.  $\square$

More generally, we can define a Heegaard splitting  $S$  of a compression body  $H$  to be *trivial* if the splitting surface is parallel to  $\partial_+ H$  or if  $S = \partial(N(\partial H \cup \gamma)) \setminus \partial H$ , for  $\gamma = (\{\text{point}\} \times I) \subset \partial_- H \times I$ , assuming that  $\partial_- H \neq \emptyset$ . It's *standard* if it's a stabilization of one of the trivial splittings.

**Proposition 2.3.** *Let  $M$  be a compression body, and  $S$  be a Heegaard splitting for  $M$ . Then  $S$  is standard.*

**Proof.** The argument of [14, 2.7] reduces the proof to that of Proposition 2.2.  $\square$

### 3. Proof of Theorem 1.1

We may remove any zeroagonal faces from consideration by the argument of [14, 2.7]. If there exists a monogonal face  $T_2^0$  having edge  $T_1^0$ , then  $T_1^0$  is boundary parallel, and hence inessential. We remove  $T_1^0$  by isotoping it into the boundary through  $T_2^0$ . This eliminates the face  $T_2^0$  and replaces all other copies of  $T_1^0$  by a strip of  $\partial M$ . Hence we may assume that all faces are bigonal or triangular.

Let  $p$  be the number of components of  $T_1$ . Then  $S_0, \dots, S_p$  are the level surfaces determining the width of  $T$ ;  $S_0$  intersects all components of  $T_1$  twice,  $S_1$  intersects all but one twice, etc.. The Heegaard surface  $S$  is obtained from  $S_0$  by adding some (perhaps no) 1-handles, each of which can be chosen to fall outside of some  $\epsilon$ -neighborhood of  $S_0 \cap T_2$ . Thus we may consider  $S$  as a single boundary parallel surface perhaps union some tubes which we may think of as being very thin.

Recall that  $S$  separates  $M$  into the compression body  $H_0$  and the handlebody  $H_1$ , with  $H_1$  lying above  $S$  and  $H_0$  lying below. Let  $X$  be a spine of  $H_0$  as given by the argument of [14, 4.1], that is,  $X$  is disjoint from  $T_1$ .  $X$  is a 1-complex properly imbedded in  $M$ , with a non-empty boundary lying in  $\partial M$ . The point here is to think of  $S$  as being one of the boundary components of  $H_0$  where  $H_0$  is a very small neighborhood of  $X \cup \partial M$ .

If  $X$  is empty, then  $M$  is already a handlebody, the splitting surface is boundary parallel, and the argument ends. Thus assume that  $X \neq \emptyset$ .

Consider  $X \cap T_3$ .  $X$  intersects  $T_2$  in points. We can think of  $X \cap T_3$  as a (possibly disconnected) graph properly imbedded in  $T_3$ . In the following argument, we will allow the edges of  $X$  to slide completely or partially over each other, as well as past vertices, to simplify the picture.

If  $X \cap T_3^j$  contains a circuit,  $\alpha$ , in  $H_0$ , say, then  $H_0 \setminus N(\alpha)$  is still a compression body, and  $S = \partial_+ H_0$  gives a Heegaard splitting of the reducible manifold  $M \setminus N(\alpha)$ . Then Haken's theorem [7] implies that  $S$  is also reducible as a Heegaard splitting of  $M$ . Thus we may assume that every component of  $X \cap T_3^j$  is a tree.

Let  $D$  be an essential defining disc for  $H_1$  again given by the argument of [14, 4.1], so  $D$  is disjoint from  $T_1$  and has boundary on  $\partial H_0 = N(X \cup \partial M)$ . Extend  $D$  radially by the retraction  $H_0 \rightarrow (X \cup \partial M)$ . It is clear from the appearance of  $S$  that this can be done in such a way as to preserve the property that  $D$  not intersect  $T_1$ . Thus we may consider  $D$  as a disc in  $M$  whose embedded interior is disjoint from  $T_1 \cup X \cup \partial M$  and whose (singular) boundary lies on  $X \cup \partial M$ .

Consider  $D \cap T_2$ . Since  $D$  has been chosen to miss  $T_1$ , each component of the intersection is one of the following six types:

- 1) simple closed curves,
- 2) arcs with endpoints on distinct components of  $X \cap T_2^k$ ,
- 3) arcs with one endpoint on a component of  $X \cap T_2^k$  and one on  $\partial M$ ,
- 4) arcs with endpoints on the same component of  $X \cap T_2^k$ ,
- 5) arcs with both endpoints on the same "vertex"  $T_0^l$  of  $T_2^k$ , and

6) arcs with one endpoint on either of two “vertices” in  $T_2^k$ .

The idea is to show that we can always use  $D$  either to reduce the number of intersections between  $X$  and  $T_2$ , or to conclude that after edge slides on  $X$ ,  $X \cap T_3^j$  contains a circuit.

Assume that  $D \cap T_2 = \emptyset$  for some  $i$ . If  $\partial D$  is essential in the graph  $X \cap T_3^j$  (i.e. the homotopy class of  $\partial D$  is not trivial in  $X \cap T_3^j$ ), then  $X \cap T_3^j$  must contain a circuit. If it's inessential, then  $\partial D$ , where  $D$  is considered as a disc in  $H_1$ , bounds a disc in  $H_0 = N(X \cup \partial M)$ , so the Heegaard splitting is reducible.

Thus  $D$  intersects  $T_2$ . We assume that  $\sharp(D \cap T_2)$  has been minimized over all such disc collections.

Any component of type 1 can be removed by an innermost disc argument, at the same time either lowering or not altering the number of intersections of  $X$  with  $T_2$ . Thus  $D$  intersects  $T_2$  only in arcs.

Consider the system of arcs  $D \cap T_2$  in  $D$ . Let  $\alpha$  be an outermost such arc cutting off a disc  $E \subset D$  such that the interior of  $E$  is disjoint from  $T_2$ . Let  $\beta = \partial E \setminus \alpha$ .

$\alpha$  is type 2: Let  $q$  be the component of  $X \cap T_3$  intersecting  $\alpha$ . If  $q$  is a single arc with both endpoints on  $T_2^k$ , connected by  $\alpha$ , then  $E$  describes an isotopy which removes the two points of intersection of  $q$  with  $T_2^k$ . If  $q$  is more complicated, let  $x$  be a point of intersection between  $q$  and  $T_2^k$  such that  $\beta$  begins at  $x$  and travels over  $X$ . Let  $z$  be the edge of  $q$  coming into  $x$ . Then  $\beta$  describes a series of edge slides of  $z$  over  $q$  and a small piece of  $T_2$ , which cuminate by introducing an extra point of intersection between  $X$  and  $T_2^k$ . However, after this series of slides the disc  $E$  runs only over the edge  $z$  so we can then reduce the number of intersections between  $X$  and  $T_2^k$  by two, see Figure 3. It is clear that this process contradicts the minimality of the number of intersections between  $X$  and  $T_2$ .

$\alpha$  is of type 3: This case is identical to the type 2 case.

$\alpha$  is type 4: Let  $x$  be the endpoint of  $\alpha$  in  $T_2^k$ .  $\alpha$  forms a loop at  $x$  bounding a disc  $E'$  in  $T_2^k$ . If  ${}^\circ E' \cap D \neq \emptyset$ , we choose an innermost such  $E$  (it may be of a different type), and begin again.

If  $E' \cap X = \emptyset$ , construct new discs  $D_1, D_2$  from  $D$  by cutting  $D$  along  $\alpha$  and attaching a copy of  $E'$  to each piece. At least one of  $D_1, D_2$  will be essential, and it will intersect  $T_2$  in fewer components than  $D$ , contradicting minimality of  $\sharp(D \cap T_2)$ .

If  $E' \cap X \neq \emptyset$ , since  $X$  does not contain a circuit we can again use  $\beta$  to describe a sequence of arc slides to reduce the number of intersections between  $X$  and  $T_2$ , contradicting minimality, see Figure 4.

$\alpha$  is of type 5: The argument is essentially the same as for type 4.

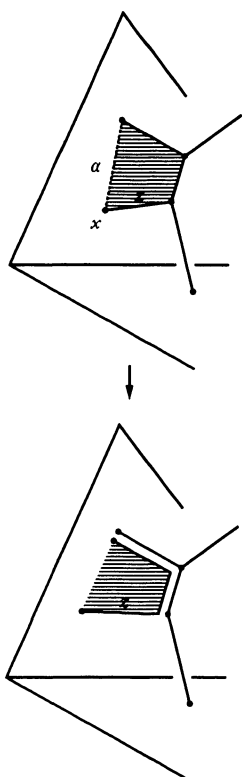

Fig. 3

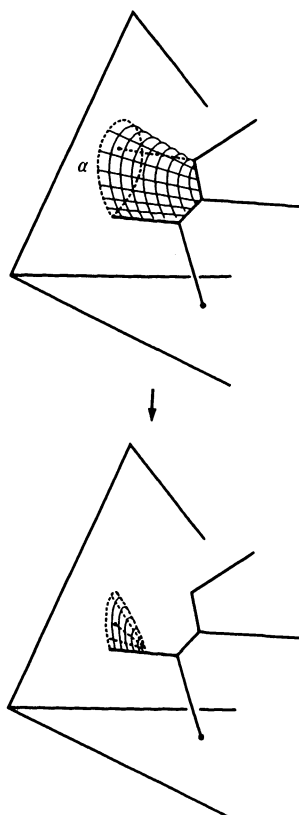

Fig. 4

$\alpha$  is of type 6: In this case the arc  $\alpha$  gives instructions for a series of edge slides on  $X$  at the end of which  $X \cap T_2$  contains an arc  $q$  isotopic to one of the arcs  $T_1^i$ , say  $T_1^1$ , see Figure 5.

Note that now an arc  $q$  of  $X$  lies precisely along  $T_1^1$ . Consider the disc obtained from  $D$  by the above process. For convenience, we again call this disc  $D$ . By construction, we see that the only edge of  $T_1$  that  $D$  can possibly touch is  $T_1^1$ . Thus there exists some  $\epsilon$ -neighborhood of  $N(q)$  such that any intersections between  $\partial N(q)$  and  $D$  in  $T_2$  occur transverse to  $\partial N(q) \cap T_2$ .

We now remove  $N(q)$  from  $M$ , forming the manifold  $M'$ . Note that  $T$  induces an IPD  $T'$  on  $M'$ , and that any Heegaard splitting with spine  $X$  containing  $q$  for  $M$  induces a Heegaard splitting for  $M'$  in the natural way, and vice versa. In fact,  $X' = X \setminus q$  is a spine for a compression body which induces a Heegaard splitting

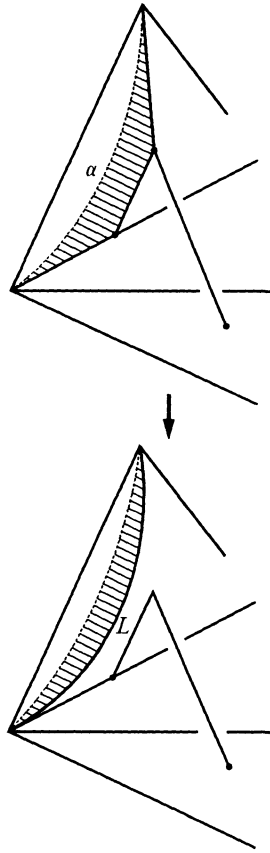

Fig. 5.

of  $M'$ . Further,  $X'$  is disjoint from  $T'_1$ . The disc  $\tilde{D} = D \subset M'$  satisfies all the properties of  $D$ , with the possible exception of minimality of intersections with the 2-skeleton  $T'_2$  of  $M'$ . Choose a disc  $D'$  whose intersection with  $T'_2$  is minimal, and repeat the above argument.

This concludes the proof of Theorem 1.1.

Note that the above argument cannot be continued beyond the  $(g-m)^{th}$  step, as after that point there is no spine  $X$  for  $H_0$  left over. Also note that if the number of edges  $p$  in  $T_1$  is less than  $g-m$ , we can immediately say that the Heegaard splitting is reducible.

**Corollary 3.1.** *Let  $M$  be a manifold without boundary which has a polyhedral decomposition  $T$  with a single vertex, and such that  $T$  fulfills requirements (2) and (3) for an IPD. If  $S$  is an irreducible Heegaard surface which is rigid with respect to  $T$ , then  $S$  is trivial.*

**Proof.** We remove a small neighborhood of the single vertex  $v$ , and apply the proof of 1.0 to the manifold  $M \setminus N(v)$ . Although the “Heegaard splittings” obtained do not precisely fulfill the definition of Heegaard splittings (they have a 2-sphere boundary component), we may “recap” this boundary component after all the above arguments are complete.  $\square$

We also note that the above argument works for manifolds with at most one boundary component possessing an arbitrary truncated polyhedral decomposition. In this case, the argument shows that, after edge slides, some edge  $q \in X$  lies entirely inside a face  $T_2^k$ , connecting two vertices. If the face  $T_2^k$  has more than three boundary components, however, the edge  $q$  may be, for example, the diagonal of a rectangular face rather than one of the edges of the 1-skeleton. Nonetheless, this argument shows that the number of possible Heegaard splittings of such a 3-manifold is finite.

**Corollary 3.2.** *Let  $M$  be a 3-manifold and  $T$  be an IPD for  $M$ . If  $S$  is an irreducible Heegaard surface which is rigid with respect  $T$ , and such that  $M \setminus S$  consists of one handlebody and one compression body, then  $S$  is trivial.*

**Proof.** We note that in the case where all boundary components of  $M$  lie in the same compression body  $H_0$ , all components of the 1-skeleton  $T_1$  of  $T$  have exactly one maximum. Then the lemma [14, 4.1] of Scharlemann-Thompson allows us to find the appropriate  $X$  and  $D$ , so that we may follow the proof of Theorem 1.1.  $\square$

We note that this crucial lemma of Scharlemann and Thompson fails in the case where  $M \setminus S = H_0 \cup H_1$  where both of the  $H_i$  are **not** handlebodies.

#### 4. Weak Reducibility

We first prove Corollary 1.2.

Let  $S$  be a weakly reducible, irreducible Heegaard splitting of  $M$ . Then by [4], we can choose a collection of weakly compressing discs  $\Delta$  for  $S$  such that after compression along  $\Delta$ , the new surface  $S'$  is incompressible. Since it is obtained by compression of a Heegaard surface, it must be 2-sided. Following the idea of [14], we choose the smallest possible set of weakly compressing discs with the above property.

If  $M$  has no boundary component, the proof of [14, 5.1, Case 1] shows that  $S$  is reducible, a contradiction. Hence all Heegaard splittings of  $M$  are trivial.

Thus we assume that  $M$  has a single boundary component, so that  $S'$  is a collection of boundary parallel surfaces. The proof of [14, 5.1, Case 2] eliminates all cases in which  $\#(S') > 2$ . If  $\#(S') = 1$ , the splitting is trivial inductively.

Thus  $\sharp(S') = 2$ . Then by reconstructing  $S$  from  $S'$ , we can see that  $S$  induces a Heegaard splitting on each layer of  $M \setminus S'$ , see Figure 6. The “innermost layer” is

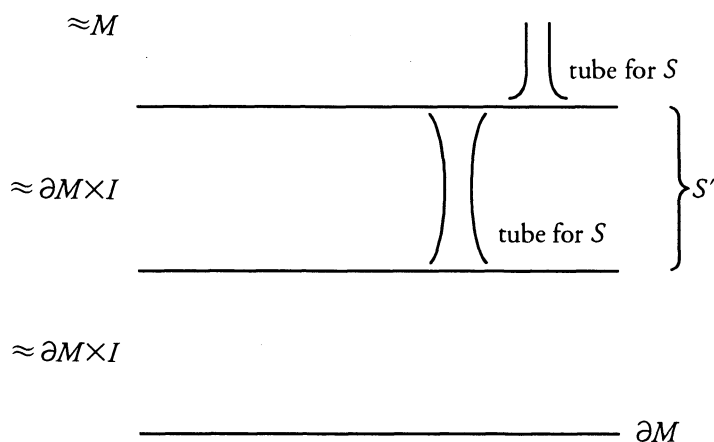

Fig. 6.

homeomorphic to  $M$ , and thus its splitting must be trivial inductively. The layer between the two components of  $S'$  is just  $\partial M \times I$ , a trivial compression body, and thus its Heegaard splitting must be trivial by the main result of [14], i.e., induced by a single vertical arc. But then  $S$  is obtained by amalgamating a trivial splitting of  $\partial M \times I$ , that is to say, a collar of  $\partial M$ , with a trivial splitting of  $M$ . This completes the proof of 1.2.

This second type of Heegaard splitting is called *almost trivial*. It should be noted that in all cases observed as of this writing, almost trivial Heegaard splittings are reducible.

In considering the (Haken) case, i.e., when there exist non-boundary parallel incompressible surfaces in  $M$ , we note that there are two difficulties: the proof of weak reducibility, and the proof of theorem 1.0 in the case of multiple boundary components.

We note, however, that if both of these obstacles can be overcome, we could immediately classify all irreducible Heegaard splittings of manifolds with finitely many non-parallel Haken surfaces as well. The process would proceed as follows:

(A) Find a polyhedral decomposition  $T$  for  $M$  which satisfies conditions (2) and (3) for an IPD. Check all subsets of the 1-skeleton of  $T$  to find the trivial Heegaard splittings.

(B) Let  $F = F_1, \dots, F_m$  be a collection of non-intersecting 2-sided Haken surfaces such that if  $F_i, F_j$ , and  $F_k$  are mutually parallel surfaces, then  $i = j$ ,  $i = k$ , or  $j = k$ ; there are at most two parallel copies of any surface in  $F$ . Cut  $M$  along  $F$

to obtain  $M_1, \dots, M_n$ , and complete step (A) on each  $M_i$ .

(C) Amalgamate the Heegaard splittings obtained in (B) along  $F$ . Discard those Heegaard splittings which are stabilized. We note that by the argument of [14, 5.1, Case 2] we do not need to consider more than two parallel copies of any  $F_i$ .

(D) Continue this process along all possible collections  $F$ .

This second type of Heegaard splitting (obtained from cutting along Haken surfaces, triangulating the pieces, obtaining trivial Heegaard splittings of those pieces, and amalgamating these along the Haken surfaces) we shall call *Haken-trivial*. Note that almost trivial Heegaard splittings are special cases of Haken-trivial Heegaard splittings.

We suggest that using the canonical “polyhedral decomposition” for cusped hyperbolic manifolds due to Epstein and Penner [5], or the canonical polyhedral decomposition of hyperbolic manifolds with totally geodesic boundary due to Kojima [10], together with the above procedure, it may be possible to classify all Heegaard splittings of hyperbolic spaces, Haken or no. Of course, it may be necessary to add edges to the polyhedral decomposition in order that all faces have 3 or less edges.

We note that regardless of whether or not there exist manifolds having non-trivial and non-Haken-trivial Heegaard splittings, this process can be used to obtain interesting examples of Heegaard splittings.

### 5. Proof of Theorem 1.3

Throughout this section, let  $M$ ,  $T$ , and  $S$  be as in Theorem 1.1. Note that by the argument of Proposition 2.2, we may assume that  $M$  is not a  $\{(surface) \times I\} \cup 1\text{-handles}$ . We assume that  $T$  has been isotoped to have minimal width with respect to the Morse foliation induced by the Heegaard splitting.

We denote an arc embedded in a face  $T_2^i$  as *normal* if its endpoints lie on distinct copies of  $T_1$ . An arc imbedded in a face is *abnormal* if both its endpoints lie on the same copy of  $T_1$ . (Arcs with an endpoint on  $\partial M$  do not arise in the following argument.) A simple closed curve lying entirely on the interior of a face  $T_2^i$  is called a *simple curve*.

Let  $r$  be a regular value of  $h$  on both  $T_1$  and  $M$ . Suppose there is an abnormal arc  $\alpha$  of  $h^{-1}(r) \cap \text{some face}$ . Then  $\alpha$  together with a piece  $\gamma$  of  $T_1$  bounds a disc  $D$  in the face. We say that  $D$  is *bad* if  ${}^\circ D \cap h^{-1}(r)$  is empty or consists of simple closed curves. If  $D$  is bad,  $\gamma$  is *above*  $h^{-1}(r)$  if it lies on the side of  $h^{-1}(r)$  containing  $h^{-1}(1)$ ; otherwise it is *below*. A bad disc lies above or below  $h^{-1}(r)$  according to whether  $\gamma$  lies above or below, see Figure 7.

CLAIM 5.1 (Gabai). Let  $r$  be a regular value of  $h$  on both  $T_1$  and  $M$ . Then  $h^{-1}(r) \cap (faces)$  cannot contain abnormal arcs  $\alpha_0, \alpha_1$  cutting off bad discs  $D_0$  and



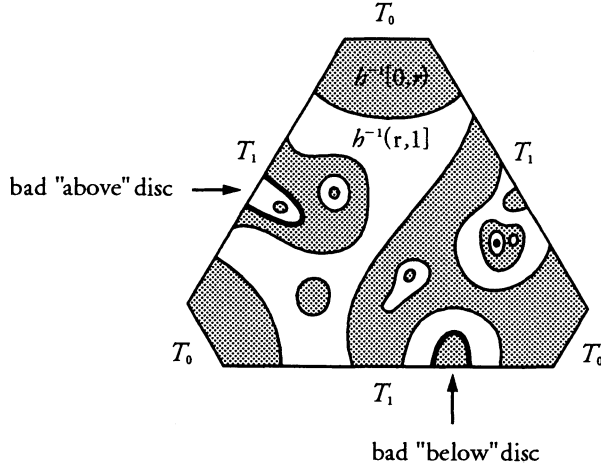

Fig. 7.

$D_1$  such that  $D_0$  is above  $h^{-1}(r)$  and  $D_1$  is below.

Proof. [6, §4]. □

CLAIM 5.2. For some regular value  $r$  of  $h$  (on  $T_1, M$ , and  $\cup T_2^i$ ),  $\#(h^{-1}(r) \cap T_1) \geq 4$ , and  $h^{-1}(r) \cap T_2$  contains no abnormal arc. That is,  $h^{-1}(r) \cap T_2$  is composed of normal arcs and simple curves.

Proof. Note that since  $S$  is not weakly rigid,  $h|_{T_1}$  has more than one critical value. Then for some  $i$ ,  $I_i$  is a minimum and  $I_{i+1}$  is a maximum. For every  $r$  such that  $I_i < r < I_{i+1}$ ,  $T_1$  intersects  $h^{-1}(r)$  in at least three points. For  $r$  very close to  $I_i$ ,  $h^{-1}(r) \cap (\text{sides})$  will contain some bad discs below  $h^{-1}(r)$ . For  $r$  very close to  $I_{i+1}$ ,  $h^{-1}(r) \cap (\text{sides})$  will contain some bad discs above  $h^{-1}(r)$ . Again as in [6, §4], we can conclude that either for some regular value  $r$  of  $h$  (on  $T_1, M$ , and  $T_2$ ),  $I_i < r < I_{i+1}$  there are disjoint bad discs both above and below  $h^{-1}(r)$ , or that there exists a regular value  $r$ ,  $I_i < r < I_{i+1}$  such that  $h^{-1}(r) \cap (\text{faces})$  contains no bad discs on either side. By Claim 5.1, the first case cannot occur, hence the second case must hold.

Since there are no bad discs, every arc of  $h^{-1}(r) \cap T_2$  is normal. Then  $h^{-1}(r)$  intersects  $T_2$  in normal arcs and simple curves. Since  $T_1$  has at least one maximum immediately above  $h^{-1}(r)$  and at least one minimum immediately below  $h^{-1}(r)$ ,  $h^{-1}(r)$  intersects  $T_1$  in at least three distinct points. We thus need only to prove that it cannot intersect in exactly three points. Assume the converse.

The intersection of  $h^{-1}(r)$  with a zero-gonal face must be in simple curves only. We may thus ignore such faces for the purposes of this argument.

Assume that  $T_2$  contains a monogonal face,  $T_2^k$ . Then any arc in  $T_2^k$  must be abnormal, a contradiction.

Assume that  $T_2$  contains a triangular face,  $T_2^k$ , and that  $h^{-1}(r) \cap T_1 = 3$ . Then the normal arcs in  $h^{-1}(r) \cap T_2^k$  must have a total of 9 endpoints, since there are three copies of  $T_1$  which serve as edges for  $T_2^k$ . But each normal arc has exactly two endpoints, so that the number of endpoints must be even, a contradiction. Thus  $\#(h^{-1}(r) \cap T_1)$  cannot be 3, and hence is at least 4.

Thus we assume that  $T_2$  consists solely of bigons. But then  $M$  is an  $I$ -bundle. A trivial  $I$ -bundle is a compression body, so  $M$  is non-trivial.

Assume that  $\#(h^{-1}(r) \cap T_1) = 3$ . The Heegaard splitting surface  $S$  is constructed from  $h^{-1}(r)$  by 1-surgery along arcs lying in  $h^{-1}([r, 1])$ . We use  $h^{-1}(r)$  to cut  $T_3$  into pieces, and will color the pieces obtained either black or white, alternately. Since the  $I$ -bundle is non-trivial, there is only one boundary component. Thus all pieces of  $T_3 \setminus h^{-1}(r)$  which are boundary adjacent must be the same color, say black. The next layers inward (towards the center of the manifold) must then all be white. But then the center surface must be colored white to both sides, implying that  $h^{-1}(r)$  must be one-sided. This implies that  $S$  must also be one-sided. But this is absurd, as  $S$  is a Heegaard surface. Therefore  $\#(\text{normal circles})$  is even, hence at least 4. This completes the proof of the claim.  $\square$

CLAIM 5.3. If  $\#(h^{-1}(r) \cap T_1) \geq 4$  and  $h^{-1}(r) \cap T_2$  contains no abnormal arc, then  $S$  is weakly reducible.

Proof. Let  $\mu$  be the 1-complex  $h^{-1}(r) \cap T_2 \setminus \text{simple curves}$ , and let  $U \subset h^{-1}(r)$  be a regular neighborhood of  $\mu$  in  $h^{-1}(r)$ , see Figure 8. Then each component of  $\partial U$  is compressible in  $M \setminus U$  (in fact, inside a component of  $T_3$ ).  $\square$

Case 1:  $a_k < r < b_1$ .

Then  $h^{-1}(r)$  is isotopic to the splitting surface  $S$ , dividing  $M$  into a compression body  $H_0$  and a handlebody  $H_1$ . If  $\partial U$  does not bound a collection  $\Delta$  of discs entirely contained in a single  $H_i$ , then by [14, 2.6]  $S$  is weakly reducible. Thus we assume that  $\Delta$  is contained in a single  $H_i$ . Without loss of generality, we assume that  $\Delta \subset H_0$ .

The surface obtained from compression along  $\Delta$  we call  $\bar{S}$ , see Figure 9. Similarly, let  $\bar{H}_0 = H_0 \setminus N(\Delta)$  and  $\bar{H}_1 = H_1 \cup N(\Delta)$ . Note then that  $\bar{H}_0$  is a union of compression bodies and  $\bar{H}_1$  is connected.

Consider  $\bar{M} = M \setminus \bar{S}$ . Color the components of  $\bar{M}$  alternately black and white. Then either the black components are  $\bar{H}_0$  and the white are  $\bar{H}_1$  or vice versa. Since  $h^{-1}(r) \cap T_2$  consists of normal arcs in  $T_2$ ,  $\bar{S}$  consists of boundary parallel surfaces.

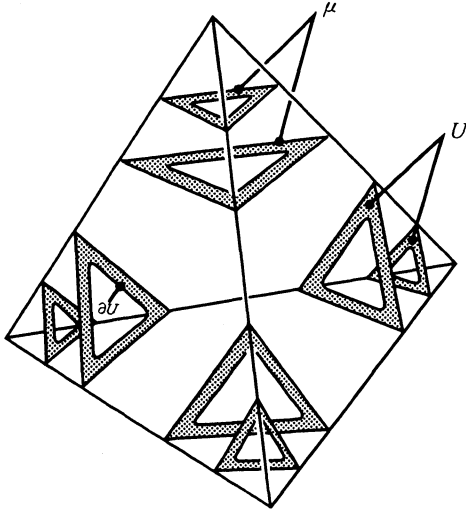

Fig. 8

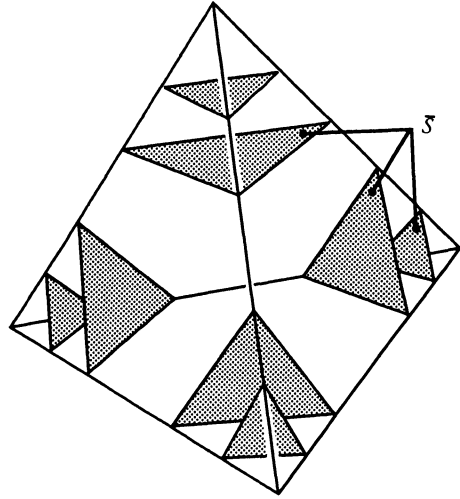

Fig. 9

If  $\#(\mu) \geq 3$ , then  $\bar{S}$  consists of (at least three) boundary parallel surfaces. But then  $\bar{M}$  contains at least four disconnected components, two of which are black and two of which are white. This implies that  $\bar{H}_1$  is disconnected, a contradiction.

Hence  $\#(\mu) = 2$ . But in this case,  $\bar{M}$  consists of three disconnected pieces; assume that the center piece is black. Then there are two black pieces and one white. Since  $\bar{H}_1$  is connected, the union of the two black pieces is  $\bar{H}_0$ . Then  $\bar{H}_0$  consists of one piece isotopic to  $\partial M \times I$  and another isotopic to  $M$ . But this second piece is not a compression body, a contradiction.

Case 2:  $a_{i-1} < r < a_i$  for some  $i$ , or  $b_i < r < b_{i+1}$ .

The cases are symmetric, so we take  $a_{i-1} < r < a_i$ . Note that  $S$  is constructed from  $h^{-1}(r)$  by 1-surgery along arcs lying in  $h^{-1}([r, 1])$ . We can assume that the ends of these arcs are disjoint from  $U$ , so  $U$  persists into  $S$ . Now apply the argument of Case 1.

This completes the proof of claim 5.3, and hence also of Theorem 1.3.

### 6. Proof of Theorem 1.4

Let  $F$  be a 2-sided incompressible surface in  $M$ . Isotope  $F$  so as to realize the minimum number of intersections with  $T_1$ . Assume that  $F$  is compressible in the complement of  $T_1$ , and let  $D$  be such a compressing disc. Since  $F$  is incompressible,  $D \cup F$  bounds a ball to one side. We may then isotope  $F$  through this ball in order

to lower the number of intersections of  $F$  with  $T_1$ , a contradiction. Hence  $F$  is incompressible in the complement of  $T_1$ .

We use an innermost disc argument to eliminate intersections of  $F$  with  $T_2$  which are simple curves. Assume that  $F \cap T_2$  contains an abnormal arc  $\alpha$ , without loss of generality we assume that  $\alpha$  is outermost. Then  $\alpha$ , together with a sub-arc of  $T_1$ , bounds a disc in  $T_2$ . Then we double this disc (see Figure 10) to create a compressing disc for  $F$  in the complement of  $T_1$ , a contradiction.

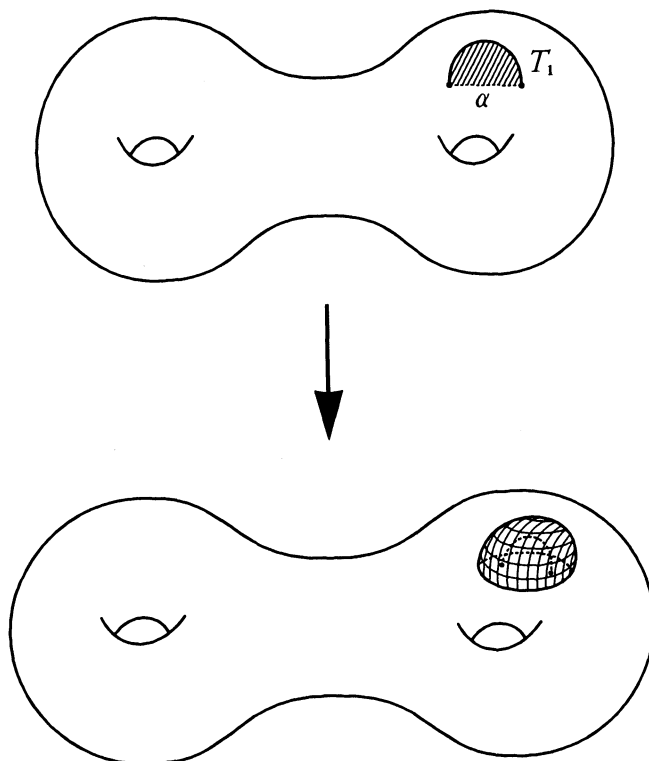

Fig. 10.

Thus we assume that  $F \cap T_2$  consists entirely of normal arcs. We move to consideration of  $F \cap T_3^i$ . If  $F \cap T_3^i$  contains a surface  $F'$  which is not a disc, then a compressing disc for  $F'$ , together with a subsurface of  $F$ , must bound a ball to one side. Again we may isotope  $F$  through this ball to obtain a surface with less intersections with  $T_1$ , a contradiction. Thus  $F \cap T_3^i$  consists of discs for each  $i$ .

If some face of  $T_2$  is a monogon, then  $F \cap T_2$  must contain an abnormal arc, a contradiction. Hence each face is either a bigon or a triangle. Any normal arcs in a bigon must be boundary parallel (see Figure 11). We thus consider the normal

arcs in a triangular face, see Figure 12.

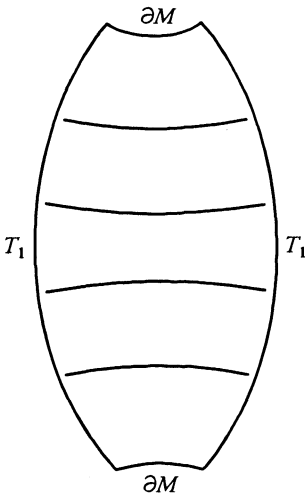

Fig. 11

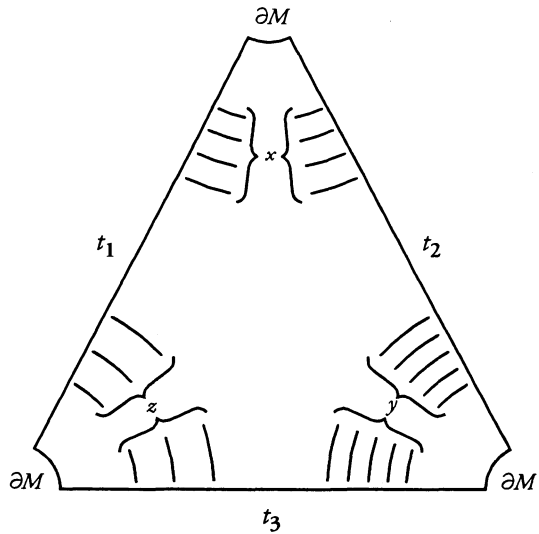

Fig. 12

Label the edges of the triangle  $t_1, t_2,$  and  $t_3$ . Note that each of the  $t_i$  is actually a copy of  $T_1$ , so that  $n = F \cap t_i = F \cap t_j$  for all  $i, j \in \{1, 2, 3\}$ . Let  $x$  be the number of normal arcs running between  $t_1$  and  $t_2$ ,  $y$  be the number of normal arcs running between  $t_2$  and  $t_3$ , and  $z$  be the number of normal arcs running between  $t_3$  and  $t_1$ . Then  $x + y = n, x + z = n,$  and  $y + z = n$ . Together, this implies that  $x = y = z = n/2$ . Thus all normal arcs are boundary parallel.

Thus  $F \cap T_3$  consists of boundary parallel discs. After making appropriate identifications of the edges of these discs, they assemble into either a boundary parallel surface, or the “center level” of a twisted  $I$ -bundle, in the case when  $T_2$  is a union of bigons with non-trivial identifications. In this latter case, however,  $F$  is 1-sided, a contradiction. This completes the proof.

### 7. Main Results

We first prove Theorem 1.5.

**Proof.** If  $S$  is a weakly rigid Heegaard splitting of  $M$  with respect to  $T$ , then  $S$  is trivial by 1.1. Thus we may assume that  $S$  is non-weakly rigid.

By Theorem 1.3,  $S$  is weakly reducible. Then by the argument of Corollary 1.2,

$S$  is trivial or almost trivial, or  $M$  has a non-boundary parallel 2-sided incompressible surface. But Theorem 1.4 eliminates the latter possibility.  $\square$

We note now that to prove Corollary 1.6, we need to show two things. First, we must demonstrate that a twisted  $I$ -bundle  $M$  over surface  $F$  has an IPD with a single edge (this is actually a well known fact). Secondly, we must show that any almost trivial Heegaard splitting of  $M$  is stabilized and hence reducible.

For a trivial  $I$ -bundle, the proof is just 2.2. Thus assume that  $M$  is a non-trivial  $I$ -bundle.

There are no non-trivial  $I$ -bundles over a sphere. In addition, a twisted  $I$ -bundle over  $RP^2$  is just  $RP^3 \setminus \{ball\}$ , and as such the proof in this case follows from [3]. We shall hence assume that  $genus(F) > 1/2$ .

Choose a vertical arc  $T_1$  in the  $I$ -bundle structure of  $M$ . Let  $A_1, \dots, A_{2k}$  be a collection of essential annuli and/or Möbius strips in  $M$  such that  $A_i \cap A_j = T_1$  for all  $i \neq j$ , and such that  $M$  cut along  $\cup A_i$  is a  $(4k\text{-gon}) \times I = T_3$ , see Figure 13.

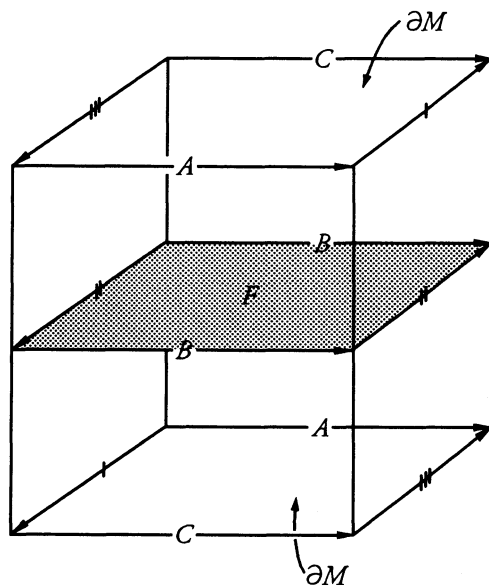

Fig. 13.

REMARK 7.1. The center surface  $(4k\text{-gon}) \times 1/2$ , together with identifications of the sides, is homeomorphic to  $F$ . If  $F$  is nonorientable, we choose the  $A_i$  in such a way that only one pair of edges of  $(4k\text{-gon}) \times 1/2$  is identified with reversal

of orientation. Otherwise, none of the edges of  $(4k\text{-gon}) \times 1/2$  are identified with reversal of orientation. In either case, the polyhedral decomposition can be taken (and we do so) so that opposite faces are identified.

Each annulus or Möbius strip contributes two sides to the  $(4k\text{-gon}) \times I$ . Each (vertex of the  $4k\text{-gon}) \times I$  is a copy of  $T_1$ . Every side is a rectangle, with one edge adjacent to the top of  $T_3$ , one to the bottom, and two edges which are copies of  $T_1$ .

Note that this decomposition defines an IPD for  $M$  in which  $T_3$  is as defined,  $T_2 =$  the sides of  $T_3$ ,  $T_1$  is as defined, and  $\partial M$  is the union of the top and bottom of  $T_3$ .

In order to finish the proof, then, we must demonstrate:

**Lemma 7.2.** *Let  $S$  be an almost trivial Heegaard splitting of  $M$ . Then  $S$  is stabilized.*

*Proof.* The proof proceeds by construction of discs  $D_i \subset H_i$  such that  $\partial D_0 \cap \partial D_1 = \{1 \text{ point}\}$ . We note that Figures 14–15 actually constitute a proof by picture, since the proof in the higher genus case proceeds by simply ignoring the extra sides of  $T_3$ . Nonetheless, we give the argument in full.

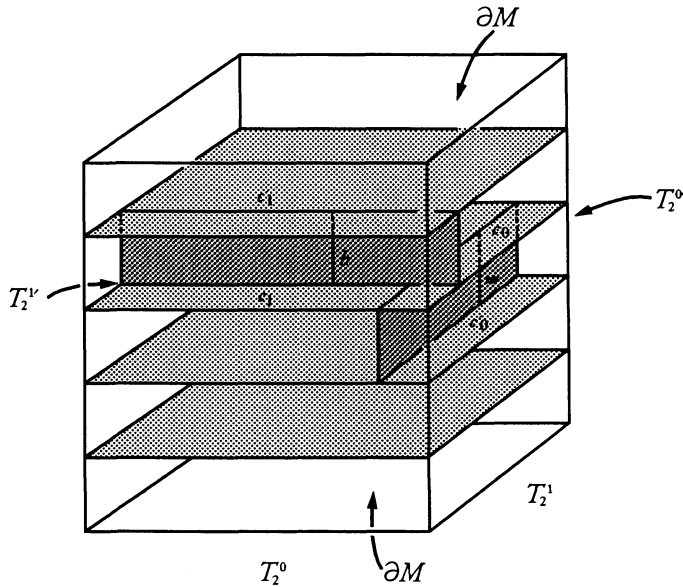

Fig. 14.

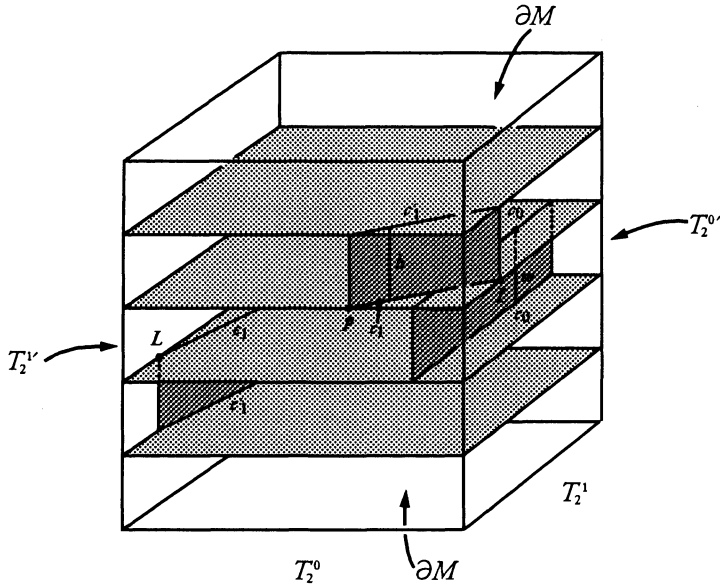

Fig. 15.

The splitting surface  $S$  divides  $M$  into two compression bodies; color  $H_0$  black and  $H_1$ , the handlebody, white. Recall that  $S$  is obtained from an amalgamation of trivial Heegaard splittings of  $\partial M \times I$  and  $M$ . Let  $D$  be a compressing disc for  $S$  contained in  $H_0$  such that  $D$  is just a meridian disc of the vertical tube defining the trivial Heegaard splitting of  $\partial M \times I$ , and let  $E$  be a compressing disc for  $S$  contained in  $H_1$  such that  $E$  is just a meridian disc of the vertical tube defining the trivial splitting of  $M$ .

Note that the surface  $S'$  obtained from  $S$  by compressing along  $D$  and  $E$  is incompressible in  $M$ . If we think of compressing along  $D$ , say, as adding a 2-handle to the white compression body, we can keep track of where we did the compression by properly imbedding a black arc in the complement of  $S'$  representing the co-core of the 2-handle. The surface  $S'$  consists of 2 parallel copies of  $\partial M$ . We can color the complementary regions of  $S'$  black and white in a way consistent with our original coloring, though there are now two black components and one white component. The center black region, the one isotopic to  $M$ , contains a properly imbedded vertical white arc. We denote this region by  $B$  and the white arc by  $w$ . Similarly, the white region contains a properly imbedded vertical black arc, which we denote by  $W$  and  $b$ , respectively. We can reconstruct  $S$  from  $S'$  by piping small tubular neighborhoods of the embedded arcs.

We envision  $M$  as a  $(4k\text{-gon}) \times I$ , with identifications of opposite sides in one



of the following ways:

- i) translation,
- ii) reflection through a horizontal line followed by translation,
- iii) reflection through a vertical line followed by translation, and
- iv) rotation through  $\pi$  followed by translation.

Further, at most one pair of faces is identified with either of (iii) or (iv), since we arranged for the surface  $F$  to have polyhedral decomposition in which at most one pair of edges are identified with reversal of orientation.  $\square$

Case 1: There are two pairs of sides  $T_2^0, T_2^{0'}$  and  $T_2^1, T_2^{1'}$  having type (i) and/or (iii) identifications.

Let  $c_0$  and  $c_1$  be a pair of essential simple closed curves on  $\partial W = \partial_+ B$ , such that  $c_i$  considered as a subset of  $T_3 = cl(M \setminus N(\cup A_i))$  is a straight line segment beginning in  $T_2^i \cap S'$  and ending in  $T_2^{i'} \cap S'$ . Moreover, choose  $c_0$  so as to contain one endpoint of  $w$ , and  $c_1$  to contain the endpoint of  $b$  in  $\partial_+ W$ . Notice that  $c_0 \cap c_1 = \{1 \text{ point}\}$ . Then  $c_0$  together with another curve  $c'_0 \subset \partial B$  bounds an annulus  $P_0$  containing the arc  $w$ . Similarly,  $c_1$ , together with another curve  $c'_1 \subset \partial_- W$  bounds an annulus  $P_1$  containing the arc  $b$ , see Figure 14. By construction,  $c'_0 \cap (c_1 \cup c'_1) = \emptyset$ , and vice versa. We remove tubular neighborhoods of  $b$  and  $w$  from the  $P_i$  in order to obtain two discs  $D_0$  and  $D_1$  properly imbedded in the complement of  $S$  with  $D_i \subset H_i$ ,  $\partial D_i$  essential on  $S$ , and  $\partial D_0 \cap \partial D_1 = \{1 \text{ point}\}$ . Then the Heegaard splitting is stabilized.

Case 2: There is one pair of sides  $T_2^0, T_2^{0'}$  having type (ii) or (iv) identification, and another pair  $T_2^1, T_2^{1'}$  having type (i) or (iii) identification.

Let  $c_0$  be an essential simple closed curve on  $\partial B = \partial_+ W$  such that  $c_0$  considered as a subset of  $T_3 = cl(M \setminus N(\cup A_i))$  is a pair of straight line segments, each beginning in  $T_2^0 \cap S'$  and ending in  $T_2^{0'} \cap S'$ . Moreover, choose  $c_0$  so that each of the two line segments composing it contains an endpoint of  $w$ . Note that  $c_0$  is non-separating and hence essential in  $\partial B$ . Then  $c_0$  bounds a Möbius strip  $P_0$  containing the arc  $w$ . Construct  $P_1$  as per case 1. We get a picture just like Figure 14, except that  $c'_0$  of that figure should also be labelled  $c_0$ . Then the discs  $D_i$  obtained by removing tubular neighborhoods of  $w$  and  $b$  from the  $P_i$  have the same properties as those in case 1. Then the Heegaard splitting is stabilized.

Case 3: There exists a pair of sides  $T_2^0, T_2^{0'}$  having type (ii) identification, and another pair  $T_2^1, T_2^{1'}$  having either type (ii) or (iv) identification.

Let  $c_0$  be as in case 2. Choose  $c_1$  so that  $c_1$  considered as a subset of  $T_3 = cl(M \setminus N(\cup A_i))$  is a pair of straight line segments, one beginning at a point  $p \in (T_2^1 \cap \partial_+ W)$ , crossing  $c_0$  once, and ending at a point  $q \in (T_2^0 \cap \partial_+ W)$ , The other beginning at  $q \in (T_2^{0'} \cap \partial_+ W)$ , not crossing  $c_0$ , and ending at  $p \in (T_2^{1'} \cap \partial_+ W)$ . Again, choose

$c_1$  to contain the endpoint of  $b$  in  $\partial_+ W$ , see Figure 15. Note that  $c_0 \cap c_1 = \{1 \text{ point}\}$ , so that  $c_1$  must be essential. Construct  $P_i, D_i$  as for the previous cases. Then the Heegaard splitting is stabilized.

This completes the proof of the lemma, and hence also of Corollary 1.6.

## 8. Other Examples

EXAMPLE 8.1. Let  $\tilde{T}$  be a regular ideal tetrahedron in  $H^3$ , that is, a tetrahedron with all four vertices on the sphere at  $\infty$  and all dihedral angles  $\pi/3$ . Then, in Figure 16, identify faces  $A$  to  $A'$  and  $B$  to  $B'$  so that the orientations on the edges match up correctly. Such identifications can be performed by orientation reversing hyperbolic isometries. After the identifications, all six edges will be identified and the sum of the angles around this one edge,  $T_1$ , will now be  $2\pi$ .

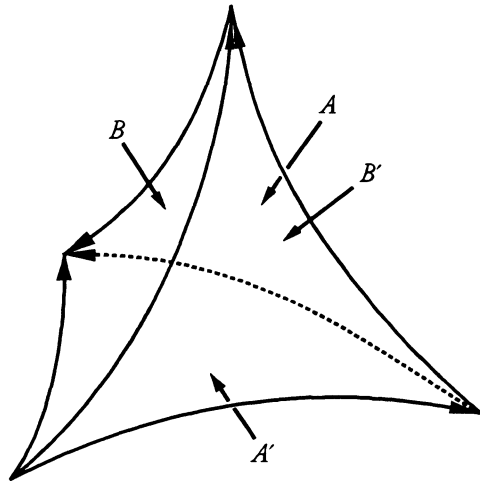

Fig. 16.

The resulting manifold,  $G$ , is a noncompact hyperbolic 3-manifold called the *Gieseking manifold*, which has been shown in [1] to be the noncompact hyperbolic manifold of minimal volume, i.e.,  $v(G) = 1.01494\dots$ . It is double covered by the figure 8 knot complement.

Let  $T$  be the IPD constructed by removing a small neighborhood of the vertex of  $\tilde{T}$ . Then 1.6 shows that all irreducible Heegaard splittings of  $G$  are either trivial or almost trivial.

But Figure 17 shows two discs  $D_i \subset H_i$  for the almost trivial Heegaard splitting whose boundaries intersect in a single point. Thus almost trivial splittings are

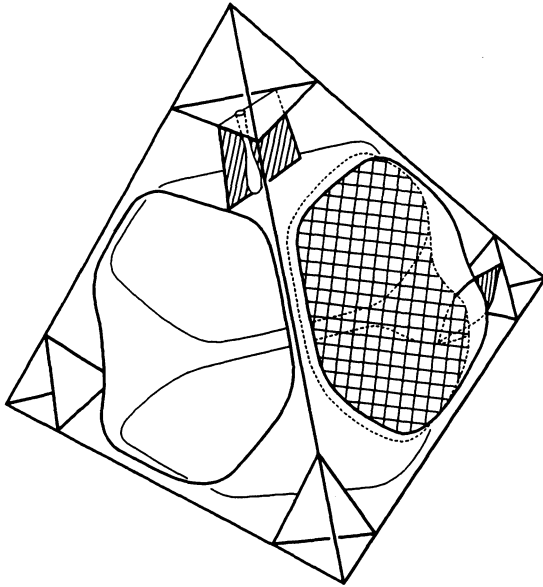

Fig. 17

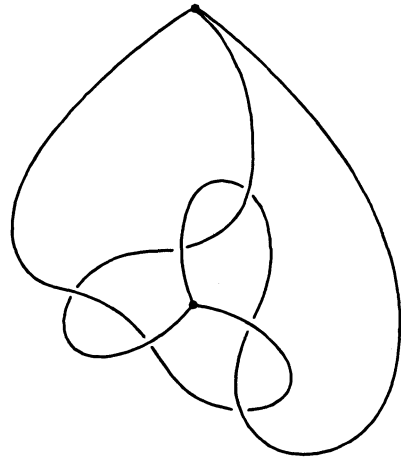

Fig. 18

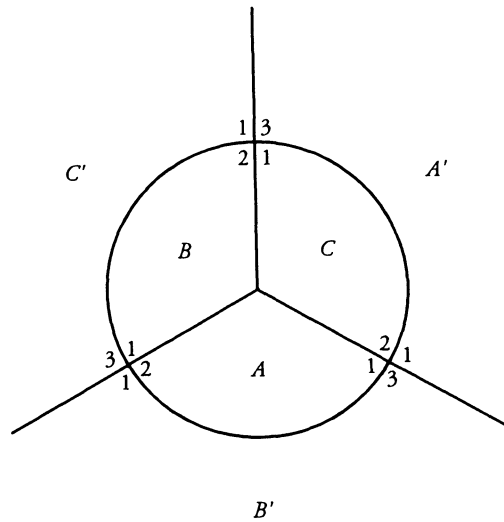

Fig. 19.

stabilized, hence Heegaard splittings of  $G$  are standard.

EXAMPLE 8.2. The theta curve of Figure 18 was first discussed by Thurston in

[16]. Its complement is a hyperbolic manifold  $N$  with totally geodesic boundary, having IPD obtained from Figure 19 by truncating the vertex. Applying 1.5 we see that all irreducible Heegaard splittings of  $N$  are trivial or almost trivial.

As per example 8.1, it is elementary to show that the almost trivial Heegaard splitting is stabilized.

---

### References

- [1] C. Adams: *The noncompact hyperbolic 3-manifold of minimal volume*, Proc. Amer. Math. Soc. **100** (1987), 601–606.
- [2] S. Bleiler and Y. Moriah: *Heegaard splittings and branched coverings of  $B^3$* , Math. Ann. **281** (1988), 531–543.
- [3] F. Bonahon and J. P. Otal: *Scindements de Heegaard des espaces lenticulaires*, Ann. Sci. Ecole Norm. Sup. **16** (1983), 451–466.
- [4] A. Casson and C. Gordon: *Reducing Heegaard splittings*, Topology and its applications **27** (1987), 275–283.
- [5] D. B. A. Epstein and R. C. Penner: *Euclidean decompositions of noncompact hyperbolic manifolds*, J. Diff. Geom. **27** (1988), 67–80.
- [6] D. Gabai: *Foliations and the topology of 3-manifolds III*, J. Diff. Geom., **18**, **26** (1983, 1987), 445–503, 461–536.
- [7] W. Haken: *Some Results on Surfaces in 3-manifolds*, Studies in Modern Topology, Math. Assoc. Amer., 1968, 39–98.
- [8] A. Hatcher and W. Thurston: *Incompressible surfaces in 2-bridge knot complements*, Inv. Math., **79** (1985), 225–246.
- [9] D. Heath: *Heegaard Splittings of I-bundles and  $RP^2 \times S^1$  are standard*, Dissertation, University of California at Davis Department of Mathematics, March 1994.
- [10] S. Kojima: *Polyhedral decomposition of hyperbolic 3-manifolds with totally geodesic boundary*, Advanced Studies in Pure Math. **20** (1992), 93–112.
- [11] Y. Moriah and H. Rubinstein: *Heegaard structures of negatively curved 3-manifolds*, preprint.
- [12] Y. Moriah and J. Schultens: *Irreducible Heegaard splittings of Seifert fibred spaces are either vertical or horizontal*, preprint.
- [13] J. Schultens: *Classification of Heegaard splittings for some Seifert fibred spaces*, dissertation.
- [14] M. Scharlemann and A. Thompson: *Heegaard splittings of (orientable surface)  $\times I$  are standard*, preprint.
- [15] A. Thompson: *Thin position and the recognition problem for  $S^3$* , preprint.
- [16] W. Thurston: *The geometry and topology of 3-manifolds*, mimeographed notes.
- [17] F. Waldhausen: *Heegaardzerlegungen der 3-sphaere*, Topology **7** (1968), 195–203.

