

Title	Studies on Novel Refining Processes for Fuel Oils by Photochemical Reaction and Liquid-Liquid Extraction
Author(s)	白石, 康浩
Citation	大阪大学, 2000, 博士論文
Version Type	VoR
URL	https://doi.org/10.11501/3169470
rights	
Note	

Osaka University Knowledge Archive : OUKA

<https://ir.library.osaka-u.ac.jp/>

Osaka University

I 9 1592

**Studies on Novel Refining Processes for Fuel Oils
by Photochemical Reaction and Liquid–Liquid Extraction**

YASUHIRO SHIRAISHI

Department of Chemical Science and Engineering

Graduate School of Engineering Science

Osaka University

2000

**Studies on Novel Refining Processes for Fuel Oils
by Photochemical Reaction and Liquid–Liquid Extraction**

YASUHIRO SHIRAISHI

Department of Chemical Science and Engineering

Graduate School of Engineering Science

Osaka University

2000

Preface

This dissertation work was carried out under the joint supervision of Professor Dr. Isao Komasaawa and Associate Professor Dr. Takayuki Hirai at the Department of Chemical Science and Engineering, Graduate School of Engineering Science, Osaka University from 1995 to 2000.

The objective of this thesis is to establish novel desulfurization, denitrogenation, and demetalation processes for fuel oils, based on photochemical reaction and liquid-liquid extraction. The author hopes that the results obtained in this work would give anyone some hint for invention of new refining and upgrading processes for petroleum feedstocks.



Yasuhiro Shiraishi

Department of Chemical Science and Engineering

Graduate School of Engineering Science

Osaka University

Toyonaka 560-8531, Japan

CONTENTS

General Introduction -----	1
Chapter I Desulfurization Behavior of Sulfur-Containing Compounds in an Oil/Water Two-Phase System -----	14
Introduction -----	14
Experimental Section -----	15
1. Materials-----	15
2. Apparatus and Procedure-----	15
3. Analysis -----	16
Results and Discussion -----	17
1. Desulfurization of Sulfur-Containing Compounds-----	17
1.1. Removal of Sulfur-Containing Compounds in Tetradecane -----	17
1.2. Removal of Sulfur-Containing Compounds in the Presence of Naphthalene -----	21
2. Effect of Triplet Photosensitizer on Desulfurization -----	24
2.1. Removal of DBT from Tetradecane -----	24
2.2. Removal of DBT in the Presence of Naphthalene-----	26
Summary -----	28
Chapter II Desulfurization of Light Oils by Photooxidation Using Hydrogen Peroxide in an Oil/Water Two-Phase System --	30
Introduction -----	30
Experimental Section -----	31
1. Materials-----	31
2. Apparatus and Procedure-----	31
3. Analysis -----	31
Results and Discussion -----	32
1. Effect of the Addition of Hydrogen Peroxide on Desulfurization -----	32
1.1. Removal of DBT from Tetradecane in the Presence of Hydrogen Peroxide -----	32
1.2. Photoreactivity of Methyl-Substituted DBTs and Benzothiophene, and the Effect of Naphthalene on the Desulfurization of DBT -----	35
1.3. Desulfurization of Light Oils in the Presence of Hydrogen Peroxide -----	37
1.4. Reactivities of Sulfur-Containing Compounds in Light Oils -----	39
2. Effect of the Both Addition of Triplet Photosensitizer and Hydrogen Peroxide on Desulfurization -----	40
2.1. Effect on Desulfurization of DBT and Decomposition of Hydrogen Peroxide -----	40
2.2. Relationship among the Concentrations of DBT, BZP, and Hydrogen Peroxide in the Desulfurization of DBT from Tetradecane-----	44
2.3. Photoreactivity of Methyl-Substituted DBTs and Benzothiophene, and the Effect of Naphthalene on the Desulfurization of DBT -----	48
2.4. Desulfurization of Light Oils Using Both Benzophenone and Hydrogen Peroxide --	50
2.5. Separation of Desulfurized Compounds from Hydrogen Peroxide Solution -----	53
Summary -----	55

Chapter III Desulfurization of Light Oils by UV Irradiation in an Organic Two-Phase Extraction System -----	57
Introduction -----	57
Experimental Section -----	58
1. Materials -----	58
2. Apparatus and Procedure -----	58
3. Analysis -----	59
Results and Discussion -----	59
1. Desulfurization Process of Light Oils Using an Organic Two-Phase System -----	59
1.1. Liquid-Liquid Extraction of Sulfur-Containing Compounds-----	59
1.2. Photoreaction of Sulfur-Containing Compounds in Polar Solvents-----	60
1.3. Desulfurization of Light Oils-----	66
1.4. Recovery of Aromatics from Acetonitrile and Effect of Addition of Water-----	70
1.5. Organization of the Overall Desulfurization Process-----	73
2. Identification of the Desulfurization Products and Reaction Pathways for Sulfur-Containing Compounds -----	75
2.1. Photoproducts and Reaction Pathway for Benzothiophene-----	75
2.2. Photoproducts and Reaction Pathways for 3-Methyl and 2,3-Dimethyl BT-----	80
2.3. Photoproducts and Reaction Pathway for Dibenzothiophene-----	83
2.4. Photoproducts and Reaction Pathways for 4-Methyl and 4,6-Dimethyl DBT-----	92
Summary -----	95
Chapter IV Desulfurization of Light Oils by Visible Light-Induced Electron-Transfer Oxidation in an Organic Two-Phase Extraction System -----	97
Introduction -----	97
Experimental Section -----	98
1. Materials -----	98
2. Apparatus and Procedure -----	98
3. Analysis -----	99
Results and Discussion -----	99
1. Photoinduced Electron-Transfer Oxidation of Sulfur Compounds -----	99
1.1. Photooxidation of Dibenzothiophene-----	99
1.2. Photooxidation of Methyl-Substituted DBTs-----	106
1.3. Photooxidation of Benzothiophenes-----	107
1.4. Effect of the Aromatic Hydrocarbons on the Photooxidation of DBT-----	109
2. Desulfurization of Light Oils by Electron-Transfer Photooxidation -----	111
2.1. Effect of DCA on the Desulfurization of Light Oils-----	111
2.2. Effect of Water on the Desulfurization of Light Oil-----	115
3. Recovery of Aromatics and DCA, and Organization of the Process -----	116
3.1. Recovery of Aromatics and DCA from Acetonitrile-----	116
3.2. Recovery of DCA from Light Oil by Solid Adsorbents-----	118
3.3. Organization of the Process-----	119
Summary -----	123

Chapter V Desulfurization of Catalytic-Cracked Gasoline by Visible Light-Induced Electron-Transfer Oxidation in an Organic Two-Phase Extraction System ----- 125

Introduction -----	125
Experimental Section -----	126
1. Materials -----	126
2. Apparatus and Procedure -----	126
3. Analysis -----	127
Results and Discussion -----	128
1. Electron-Transfer Photooxidation of Sulfur-Containing Compounds Using DCA in Acetonitrile -----	128
1.1. Photooxidation of Sulfur-Containing Compounds-----	128
1.2. Photooxidation of Sulfur-Containing Compounds in the Presence of Olefins-----	133
2. Photochemical Desulfurization of CCG Using DCA -----	134
2.1. Effect of DCA on the Desulfurization of CCG-----	134
2.2. Effect of Water on the Desulfurization of CCG and the Recovery of DCA-----	137
2.3. Organization of the Process-----	140
Summary -----	142

Chapter VI Denitrogenation of Light Oils by UV Irradiation and Liquid-Liquid Extraction ----- 143

Introduction -----	143
Experimental Section -----	144
1. Materials -----	144
2. Apparatus and Procedure -----	144
3. Analysis -----	145
4. Fractionation of Basic and Neutral Nitrogen Compounds from Light Oils -----	145
Results and Discussion -----	146
1. Composition and Distribution of Nitrogen-Containing Compounds -----	146
2. Denitrogenation Using an Oil/Water Two-Phase System -----	150
2.1. Model Nitrogen-Containing Compounds-----	150
2.2. Denitrogenation of Light Oils-----	152
2.3. Effect of Hydrogen Peroxide on Denitrogenation-----	155
2.4. Comparison with Desulfurization and Denitrogenation Abilities of the Process-----	158
3. Denitrogenation Using an Oil/Acetonitrile Two-Phase System -----	159
3.1. Extraction of Nitrogen-Containing Compounds from Light Oils-----	159
3.2. Photoreaction of Nitrogen-Containing Compounds in Acetonitrile-----	162
3.3. Denitrogenation of Light Oils-----	163
3.4. Comparison with Desulfurization and Denitrogenation Abilities of the Process-----	166
Summary -----	169

Chapter VII Demetalation of Petroleum Residues by UV Irradiation and Liquid–Liquid Extraction -----	171
Introduction -----	171
Experimental Section -----	172
1. Materials -----	172
2. Apparatus and Procedure -----	173
3. Analysis -----	175
Results and Discussion -----	176
1. Demetalation Process Consisting of Simultaneous Photoreaction and Liquid–Liquid Extraction -----	176
1.1 Demetalation of Vanadylporphyrin from Tetralin -----	176
1.2 Demetalation Mechanism of Vanadylporphyrin -----	178
1.3 Demetalation of Nickelporphyrin from Tetralin -----	184
1.4 Demetalation of Atmospheric Residue -----	184
2. Demetalation Process Consisting of Photoreaction in the Presence of Alcohol Followed by Liquid–Liquid Extraction -----	190
2.1 Photodecomposition of Vanadyl and Nickelporphyrins -----	190
2.2 Demetalation of Residue Oils -----	194
2.3 Properties of Residue Oil Products and Organization of the Process -----	197
Summary -----	200
General Conclusions -----	202
Suggestions for Future Work -----	208
(1) Development of the Closed Process for Desulfurization Using Alkylation and Precipitation Techniques -----	209
(2) Utilization of the Thiophenium Salts as Initiators for Cationic Polymerization -----	210
(3) Synthesis of the Novel Polymers Having Thiophenium Salt Moieties -----	210
Literature Cited -----	211
List of Publication -----	220
Acknowledgment -----	222

General Introduction

Petroleum crudes usually contain a considerable amount of sulfur, nitrogen, and heavy metal impurities. The sulfur and nitrogen compounds are converted by combustion to sulfur-oxides (SO_x), nitrogen-oxides (NO_x), and particulate matters, which are main sources of air pollution and acid rain. The regulations for sulfur and nitrogen emissions are now therefore becoming more stringent. The presence of these harmful elements, especially heavy metal-containing compounds (vanadium and nickel), has also an adverse effect on the commercial quality and the stability of the oils, and increases the cost of refining as a result of intensification of corrosion of the apparatus and poisoning of the catalysts. The concentration of these objectionable compounds generally increases with the boiling point of the oil products, and the requirements of their removal from heavier feedstocks are increased very significantly. The crude oils supplied are now becoming heavier, and the concentration of these compounds will therefore inevitably be increased. The significance of the further refining of the petroleum products, so called "*petroleum upgrading*," will be certainly increased in the near future.

A current petroleum refining process is shown in **Figure 1**. Petroleum crudes are first separated essentially by atmospheric distillation into several fractions such as fuel gases, naphtha, kerosene, light oil, and residue oil, according to the boiling points. The high-boiling residual fractions are then distilled under high vacuum to recover the lighter components (vacuum gas oil). Several commercial fuels are produced from each fraction through the various refining processes, so called "*hydrotreating*." These are the processes to catalytically stabilize the petroleum products and/or remove the objectionable elements from the products by the reaction with hydrogen in the presence of noble metal catalysts. Stabilization involves conversion of unsaturated hydrocarbons such as olefins and diolefins to paraffins. The objectionable elements removed by hydrotreating include sulfur, nitrogen, and heavy metals. Hydrotreating is applied to a various kind of feedstocks from naphtha to vacuum residue. When the process is employed specifically for sulfur removal, it is called "*hydrodesulfurization*" (HDS). The hydrodenitrogenation (HDN) and hydrodemetalation (HDM) occur simultaneously with HDS reaction.

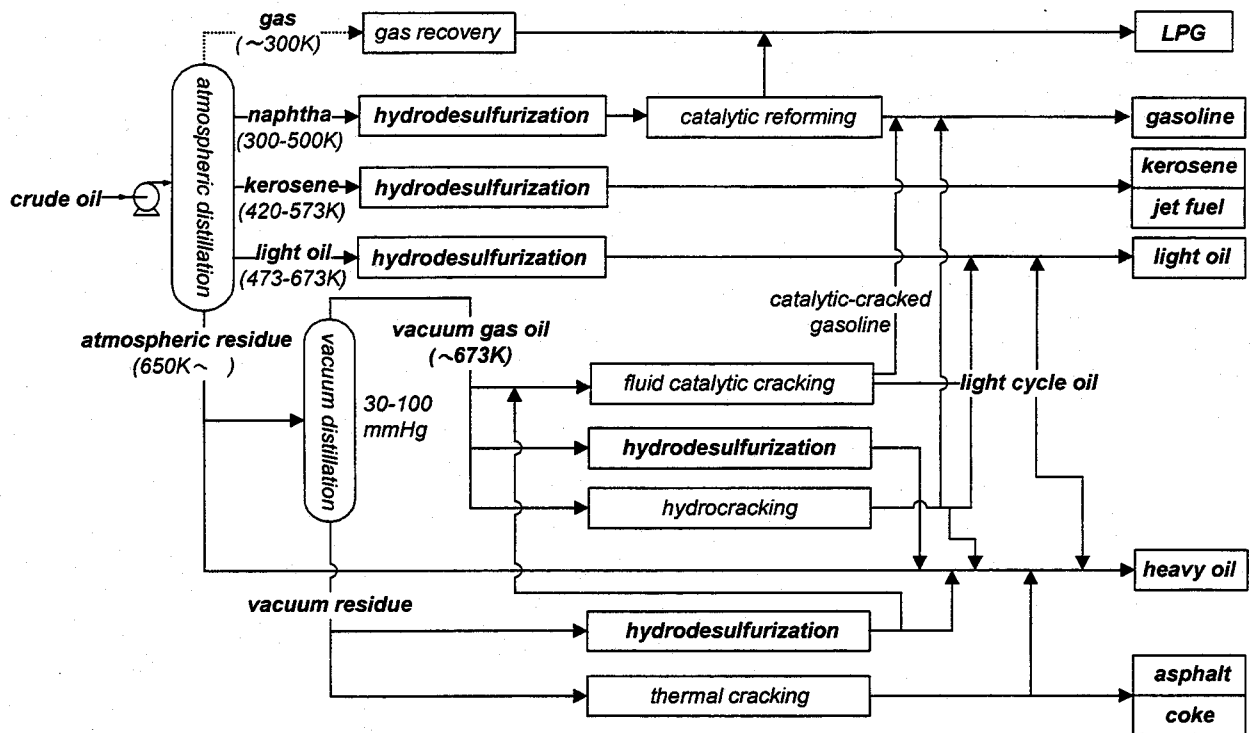

Figure 1. Basic flow scheme of petroleum refining process in refinery (Gary and Handwerk, 1984).

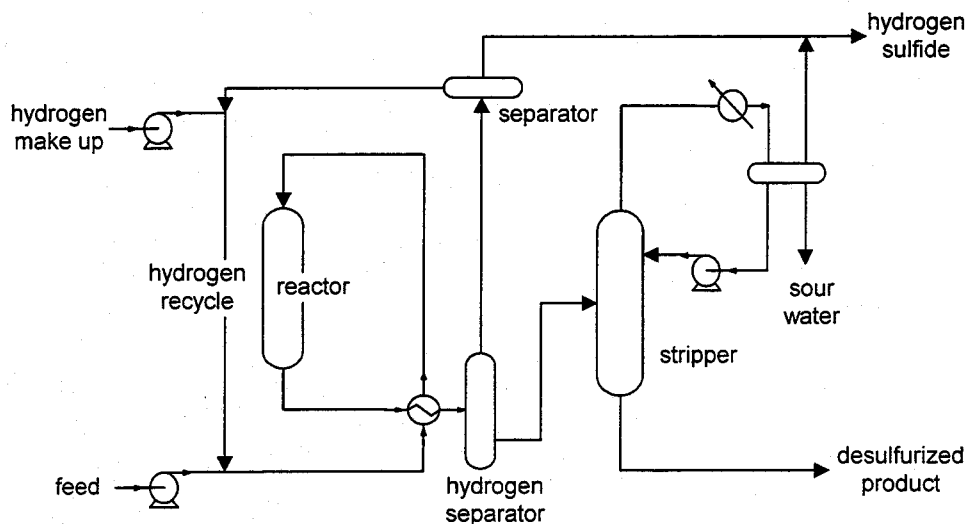

Figure 2. Catalytic hydrodesulfurization (HDS) unit in refinery.

Figure 2 shows a typical HDS unit employed in refineries. The oil feed is mixed with hydrogen-rich gas either before or after it is preheated to the proper reactor inlet temperature. These enter the top of the fixed or trickle bed reactor, and the hydrogen reacts with the oil in the presence of catalysts with small pores (high activity) to produce H_2S , NH_3 , and saturated hydrocarbons. The heavy metals remain on the surface of the catalyst and other products leave the reactor with the oil-hydrogen stream. If the oil feed

contains a large concentration of metals, HDM is carried out, prior to the HDS, using catalysts having large pores (low activity). The reactor effluent is cooled, and the product oil separated from the remaining H₂S in a stripper. The gas is then treated to remove H₂S and recycled to the further hydrotreating. The refining of the lighter petroleum products, gasoline and kerosene, is relatively easy as compared with more heavier products, light oil and residue oil, because of the lower content of objectionable components. The light oil contains a high content of sulfur and nitrogen (0.1–2 wt%), but scarcely contains heavy metals. Since all the metals are concentrated in residue oil fractions (100–1000 ppm), in addition to the high content of sulfur and nitrogen (3–4 wt%), the hydroprocessing for residue fractions are most difficult.

From recent environmental concerns, the sulfur level in light oil has been tightened from previous 0.2 wt% to less than 0.05 wt%, both in Japan and Europe on an average, and this will certainly be tightened to 0.005 wt% in the near future. The sulfur specification in Sweden and Switzerland has already been tightened to this 0.005 wt%. Recent researches concerning the HDS for light oils have revealed that sulfur-containing compounds such as dibenzothiophenes (DBTs), especially 4-methyl and 4,6-dimethyl DBT, are the most difficult compounds to be desulfurized, and this is caused by steric hindrance between the compounds and the active sites of the catalyst (Amorelli et al., 1992; Houalla et al., 1980; Kabe et al., 1992). These undesirable problems thus inevitably lead to the requirements of severe high energy conditions and a high hydrogen pressure to achieve the regulatory sulfur content value for light oil. The hydrodenitrogenation (HDN) of light oils is more difficult as compared with HDS (Girgis and Gates, 1991). The nitrogen-containing compounds deposit on the catalysts, and cause a corresponding loss in the catalyst activity (Dong et al., 1997). The production of light oil, of very low levels of sulfur and nitrogen, therefore inevitably requires rather severe conditions and specially active catalysts.

The hydrodemetalation (HDM) of residue oils is rather difficult as compared with both HDS and HDN reactions. The metal-containing compounds, such as vanadium and nickel, are present in residue oils as thermally stable metalloporphyrins. These are most difficult compounds to be demetalized by the current HDM processes, and leave a metal sulfide deposit on the catalyst. This causes a detrimental effect on catalyst activity, and

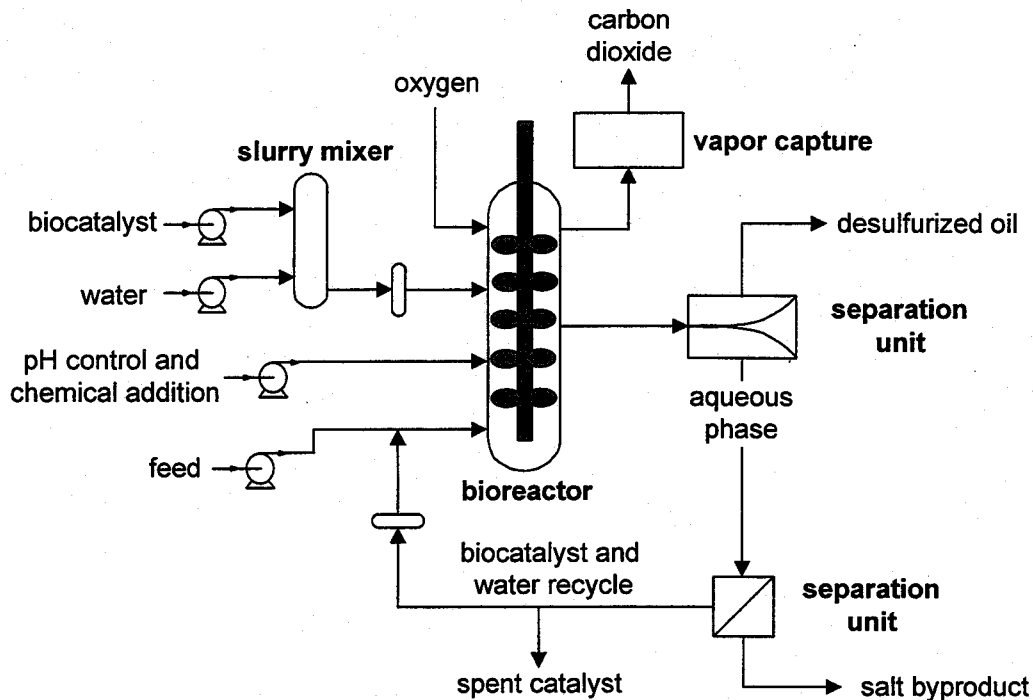

Figure 3. Biocatalytic desulfurization units proposed (Rhodes, 1995).

thus catalyst regeneration and/or replacement must therefore be carried out every one to two years. In the development of any alternative energy-efficient refining processes, a radical approach, which is not limited to the conventional hydrotreating technology, is strongly required.

A different desulfurization technique namely “*oxidative desulfurization*,” based on chemical oxidation of sulfur-containing compounds, is proposed by several researchers. The sulfur-containing compounds in light oils are oxidized by oxidizing agent such as hydrogen peroxide in the presence of acetic acid, at atmospheric pressure and a temperature of 323–373 K. The products, sulfoxide and sulfone, are highly polarized, and are removed from nonpolar light oils as solids or gummy materials (Attar and Corcoran, 1978). The reaction proceeds selectively and very fast, but the peroxide is thermally decomposed during the reaction (Heimlich and Wallace, 1966; Attar and Corcoran, 1978). Since the oxidizing agents are usually nonregenerable, regenerable oxygen carriers, such as molecular oxygen, are required for desulfurization. In addition, the present method is not effective for both denitrogenation and demetalation.

As an another approach, “*biocatalytic desulfurization*” process is proposed by Energy BioSystem Corp. (Monticello, 1994; Rhodes, 1995; Linguist and Pacheco, 1999). As

shown in **Figure 3**, aerobic bacteria suspended in aqueous solution are mixed with feed light oil. The DBTs are metabolized, at atmospheric pressure and a temperature of 303 K under air bubbling, to be converted finally to sulfate anion via oxidation of sulfur atom (Gallagher et al., 1993). The desulfurized light oil is then separated from aqueous solution, and the bacteria recovered can be reused for further desulfurization. In this process, both the denitrogenation and demetalation reactions also occur by choosing the appropriate bacteria. This biotechnological refining process, so called "*biorefining*," has now attracted attention as a key technology for petroleum refining. The removal of these objectionable compounds by bacteria takes, however, a long reaction time, and the selectivity for these compounds from other hydrocarbon components is significantly low. The present process is therefore required to develop the DNA technology that can amplify desirable biocatalytic activities and reduce undesirable side reactions.

The photoconversion of organic pollutants on seawater has been studied in the field of environmental chemistry. Sunlight-photooxidized DBTs (sulfoxide and sulfone) in spilled crude oil increase toxicity as compared with the parent DBTs. Berthou and Vignier (1986) have therefore used DBTs as organic markers for oil pollution in the marine environment. When Arabian light oil was mixed with sea water under natural irradiation, the DBTs were photooxidized to water-soluble sulfur-oxygenated compounds and were transported into the water phase. The estimated half-lives for photooxidation of mono- and dimethylated DBT were found to be longer than that of DBT. Moza et al. (1991) reported on the photodegradation of aromatic sulfur compounds dissolved in *n*-hexane and spread as a thin liquid film on water. Irradiation by a medium-pressure mercury lamp brought about the oxidation of the DBT to corresponding sulfoxide, which then moved into the water phase. If these reactions can be applied to the "*photochemical desulfurization*" of fuel oils, the process will have the following advantages: (1) No catalysts are needed. (2) It is easy to operate and control the reaction. (3) The process is energy-saving, since the reaction occurs at room temperature and under atmospheric pressure. (4) The photodecomposition of nitrogen and heavy metal-containing compounds as well as sulfur compounds may be feasible.

Based on these new concepts, the study on novel desulfurization process for light oils, based on photochemical reaction and liquid-liquid extraction, was initiated in 1993 by Mr.

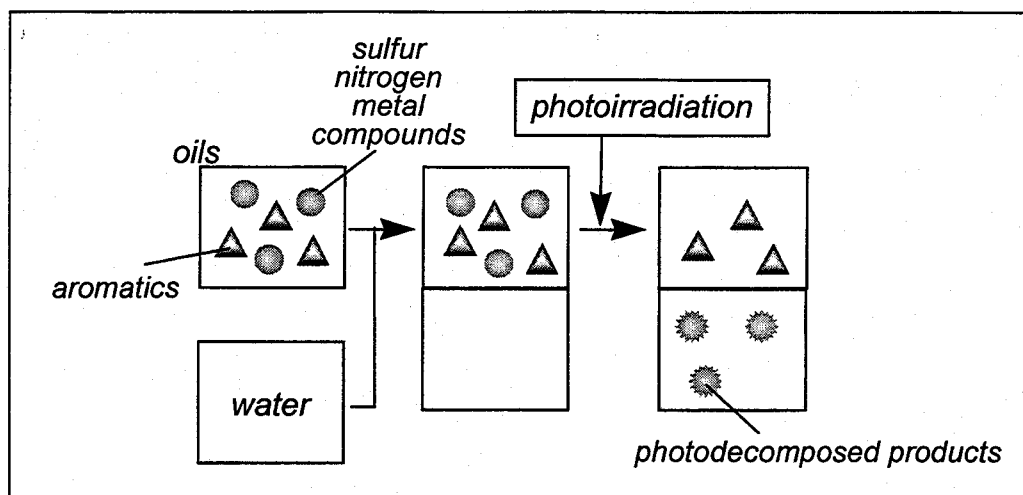

Figure 4. Basic concept for an oil/water two-phase system (in Chapter I, II, VI, and VII).

Ken Ogawa as his MSc work. The present author participated in this research project in 1995 as graduation thesis work. The results and the problems obtained are summarized as follows: An oil/water two-phase system, as shown in **Figure 4**, was first employed as separation system and entire wavelength region of light from a high-pressure mercury lamp was irradiated. The DBTs dissolved in *n*-tetradecane (model light oil) were found to be photodecomposed by UV region light (mainly $\lambda < 280$ nm) and the photodecomposed DBTs were removed into water phase as sulfate anion, under conditions of room temperature and atmospheric pressure. The reactivity of DBTs was found to be order of DBT < 4-methyl DBT < 4,6-dimethyl DBT. This is a different tendency from that reported for HDS method (Kabe et al., 1992), thus indicating that the present process is effective for desulfurization of these refractory compounds. The study, however, revealed that the removal of DBT from tetradecane was depressed markedly in the presence of bicyclic aromatic hydrocarbons such as naphthalene. This is a serious problem for desulfurization of light oils, since these contain a large amount of bicyclic aromatics. The desulfurization yield of commercial light oil, containing a 0.2 wt% sulfur, which is below the previous regulation in Japan, was only 22% following 30 h photoirradiation, and the deep desulfurization (0.05 wt%) could not be attained by the process.

The principal investigator for this research topics was switched to the present author in 1996. The main subjects of this research were set as follows:

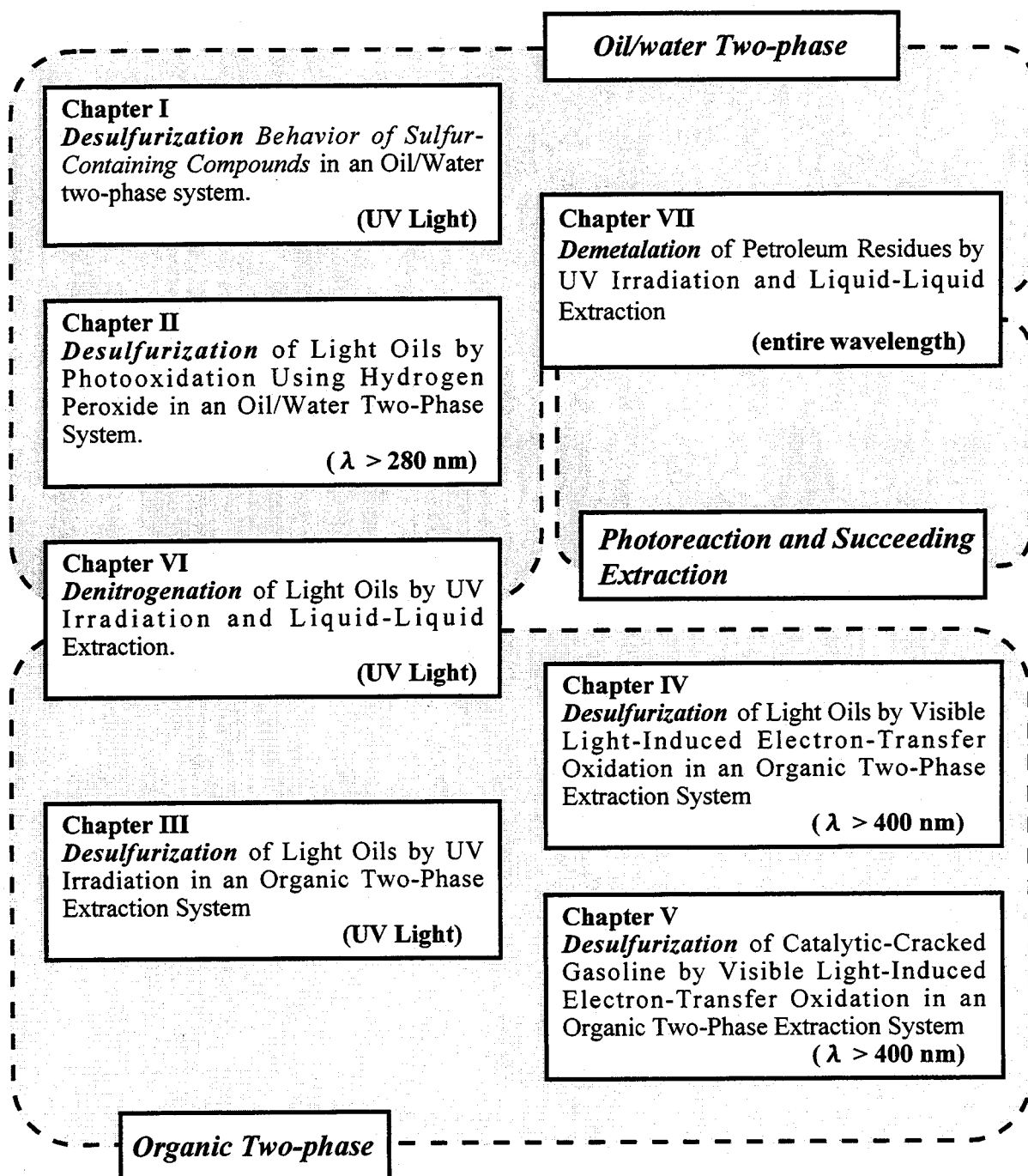

Figure 5. Framework of the present study.

(1) Enhancement of the photoreaction of DBTs in the presence of large amount of naphthalene. (2) Utilization of visible wavelength light as light sources. (3) Development of a closed process, in which solvents and materials used may be recycled. The present dissertation work includes the results of the research activities concerning these subjects. The results obtained by these desulfurization studies are extended to denitrogenation of light oils and demetalation of residue oils. These are summarized as “*photochemical refining*” processes in this dissertation thesis. There has not been any

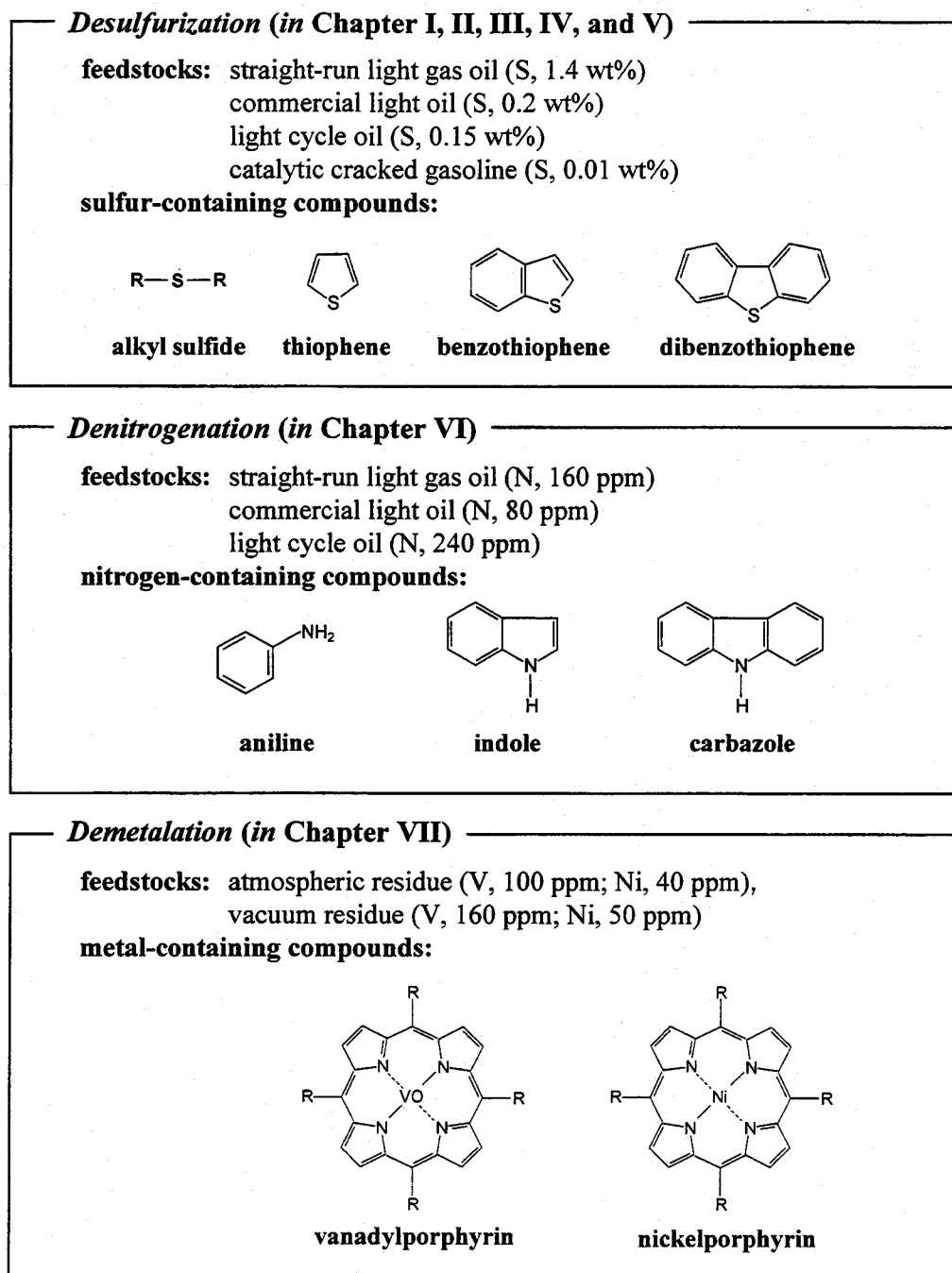

Figure 6. Feedstocks and model compounds used in the present study.

investigation devoted to these photochemistry-based refining processes for petroleum products. The framework of the present study is shown in **Figure 5**. Various photosensitizing reactions and extraction systems are investigated under several irradiation wavelengths conditions. The first four chapters of this thesis describe the investigation concerning the desulfurization of light oils. The process developed is applied to the desulfurization of lighter feedstocks, catalytic-cracked gasoline, in Chapter V.

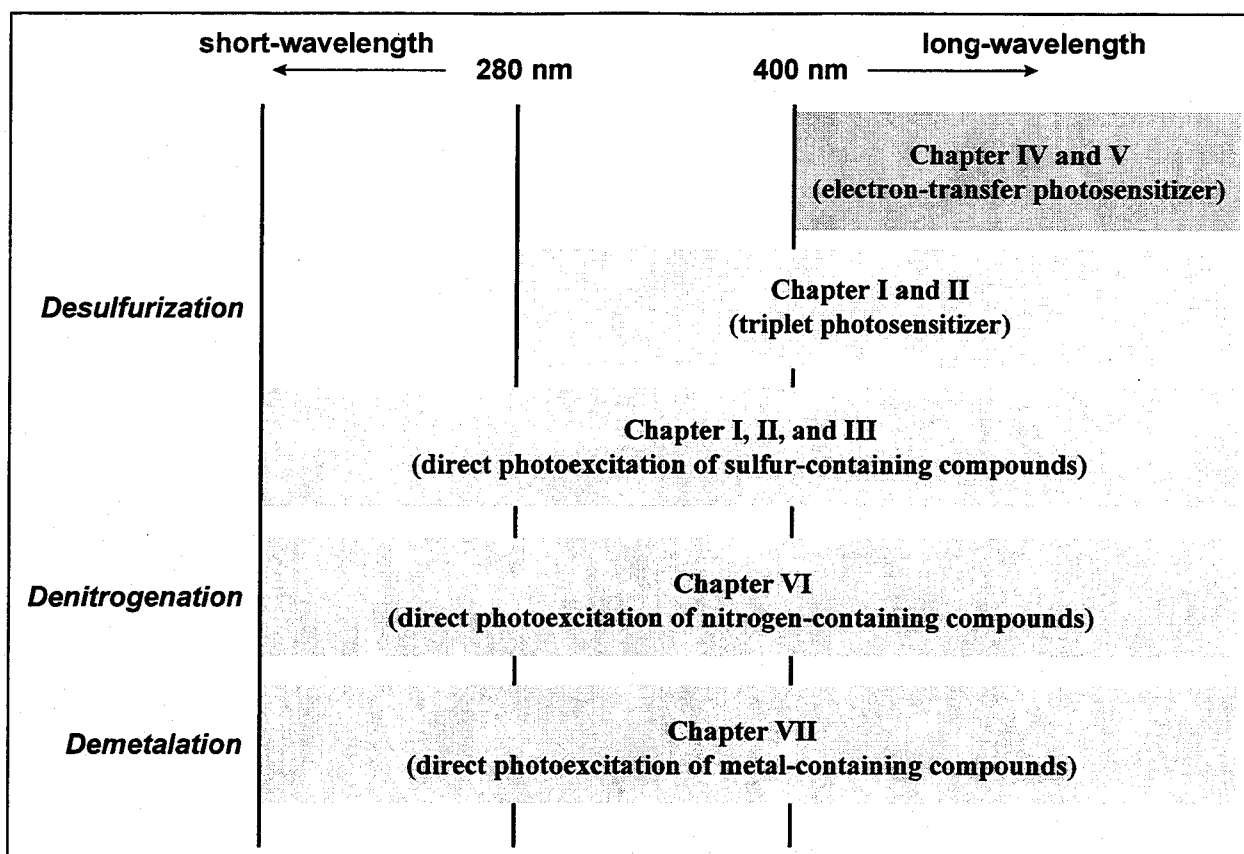

Figure 7. Wavelength region of light used in each chapter.

The denitrogenation of light oils and the demetalation of residue oils are described in the last two chapters of this thesis. In all the chapters, the chemistry of photoreactions and properties of the photoproducts for model objectionable compounds, as shown in **Figure 6**, are first studied in detail. Based on these fundamental data, an appropriate removal method for each compound from actual fuel oils is studied. The wavelength region of light used in each chapter is summarized in **Figure 7**.

This thesis consists of the following seven chapters.

In Chapter I, desulfurization behavior of several sulfur-containing compounds in light oils was studied to clarify the photoreactivity of each compound, using an oil/water two-phase system (**Figure 4**). The *n*-tetradecane solution, containing individual sulfur-containing compounds, was used as model light oil, and the results were compared with those obtained for actual light oils. The photodecomposition of DBTs in light oils was suppressed significantly by the presence of bicyclic aromatics (naphthalene derivatives), although other sulfur-containing compounds were successfully photodecomposed and were removed into the water phase. To cope with this problem, effect of the addition of

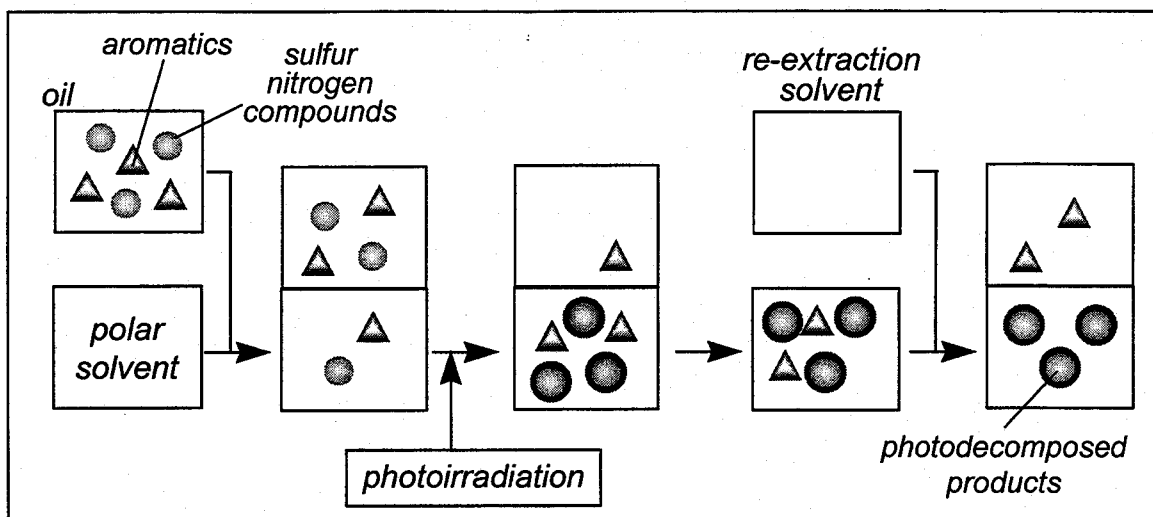

Figure 8. Basic concept for an organic two-phase extraction system (in Chapter III, IV, and V).

triplet photosensitizer to the light oil on the desulfurization of DBT was then studied, expecting to enhance the photoreaction of DBT.

In Chapter II, effect of the addition of hydrogen peroxide to the water phase on the desulfurization of DBTs from light oils was studied by the irradiation of entire wavelength region of light, using an oil/water two-phase system (**Figure 4**). This approach, however, causes photodecomposition of hydrogen peroxide and sulfur-free aromatic hydrocarbons. In order to suppress these undesirable side reactions caused by the irradiation of short-wavelength UV light ($\lambda < 280$ nm), effect of the addition of both triplet photosensitizer and hydrogen peroxide on desulfurization was then investigated, under irradiation of relatively long-wavelength light ($\lambda > 280$ nm). The indirectly photoexcited DBT by photosensitizer might be oxidized by hydrogen peroxide, and thus the direct photodecomposition of hydrogen peroxide by UV light would be suppressed significantly. The recovery process for the sulfur-containing compounds removed into the water phase was also investigated using solid adsorbents, in order to reuse the hydrogen peroxide solution for further desulfurization.

In Chapter III, a different desulfurization process using an organic two-phase extraction system (**Figure 8**) was newly developed. This is because, in an oil/water two-phase system employed in Chapters I and II, the photoexcitation of DBT occurs in nonpolar light oil phase, in which the key intermediates of DBT are not stabilized sufficiently. The concept for this new process is the transfer of the sulfur-containing

compounds to other phase at first, and then the photodecomposition of them there. The polar solvent, immiscible with nonpolar light oil, was employed, since the sulfur-containing compounds, especially DBTs, have relatively large polarity and tend to transfer to the polar solvents, together with several aromatic compounds. The DBTs might be distributed successively and photodecomposed by employing this process. The downstream process, involving the separation of sulfur-free aromatics and highly polarized sulfur-containing compounds from resulting polar solvents, was also investigated.

In Chapter IV, desulfurization process, utilizing visible wavelength light ($\lambda > 400$ nm) as light source, was studied to avoid the photodecomposition of sulfur-free aromatic hydrocarbons caused by the irradiation of short-wavelength UV light. Electron-transfer type photosensitizer, such as cyano-substituted anthracene, is photoexcited by visible light irradiation and indirectly one-electron oxidizes the sulfur-containing compounds. This type photosensitizer was added to an organic two-phase extraction system (**Figure 8**), and the feasibility of the desulfurization process utilizing visible-wavelength light was studied. The sequential processes required for the separation and recovery of photosensitizer were also studied. The overall desulfurization process was organized, and the applicability to the refining process of light oils was demonstrated.

In Chapter V, the visible light-induced desulfurization process for light oils (Chapter IV), using an organic two-phase extraction system (**Figure 8**), was applied to the desulfurization of catalytic-cracked gasoline. The photoreactivity of typical sulfur-containing compounds (thiols, disulfides, and thiophenes) contained in gasoline, and their photoproducts in the photooxidation, when spiked with electron-transfer photosensitizer, were studied in detail. The effect of the presence of olefins on the photooxidation of the sulfur-containing compounds and on the selectivity was also studied. The overall desulfurization process was developed, and the applicability to the refining process for gasoline was demonstrated, based on the properties of the gasoline produced by the proposed process.

In Chapter VI, the desulfurization processes effected by UV irradiation, described in Chapter I and III, were applied to the denitrogenation of light oils, using both oil/water (**Figure 4**) and oil/polar solvent (**Figure 8**) two-phase systems. In order to acquire the

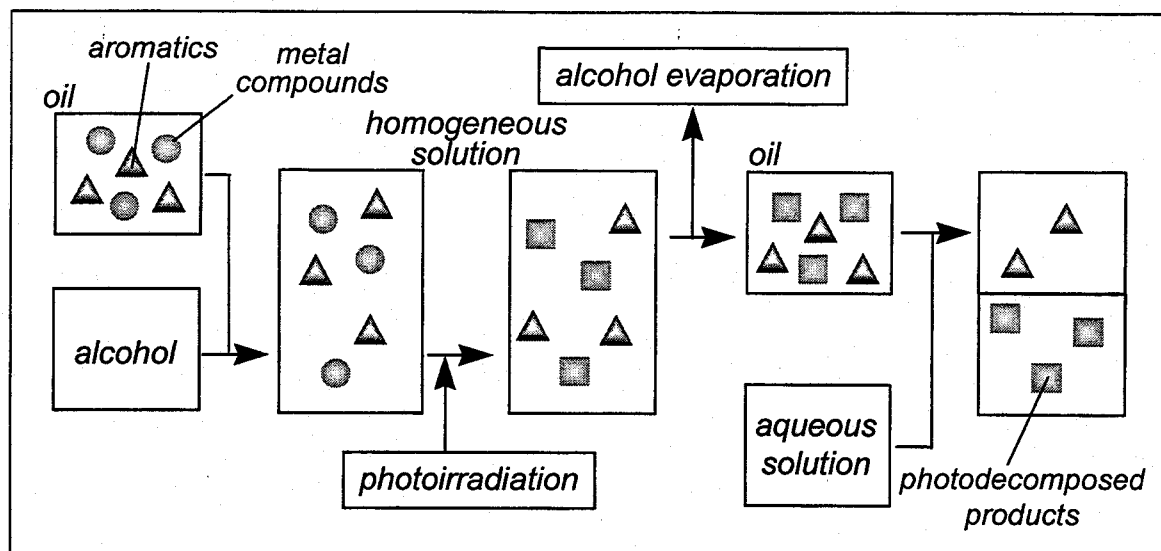

Figure 9. Basic concept for photoreaction and succeeding extraction system (in Chapter VII).

chemistry of nitrogen-containing compounds, the xylene solutions, containing individual nitrogen compounds (aniline, indole, and carbazole), were used as model solutions representing the light oil. The proposed processes were applied to the denitrogenation for actual light oils, and the feasibility of the simultaneous desulfurization and desulfurization was studied. The denitrogenation efficiencies obtained by the present processes were compared with the results for the desulfurization, and the applicability of the processes as upgrading method for light oils was demonstrated.

In Chapter VII, the demetalation process for residue oils by UV irradiation and liquid-liquid extraction was investigated, as an extension of the above desulfurization and denitrogenation studies. Simultaneous photoreaction and extraction process was first studied, using an oil/water two-phase system (**Figure 4**). The results for demetalation, obtained for vanadyl(IV) and nickel(II)tetraphenylporphyrin dissolved in tetralin (model residue oils), were compared with those obtained for actual residue oil. It is known that the residue oil contains two types of metalloporphyrins, one “free” type and the other “bound” type. The latter type metalloporphyrins are associated strongly with asphaltenic molecules. In order to weaken this association and thus to convert the “bound” type metalloporphyrins to the “free” type, a hydrogen-donating polar solvent, miscible with residue oil, was mixed and photoirradiated. This new process, photoreaction and succeeding extraction system (**Figure 9**), was employed, in which the solvent is then

recovered by evaporation and the resulting photodecomposed compounds are removed by extraction.

The results obtained in this work are summarized in General Conclusions. Suggestions for future work are described as an extension of the present work.

This research group, to which the author belongs, is called as "Chemical Process and Reaction Engineering," and a part of the Department of Chemical Science and Engineering, Osaka University. This group has concerned with "*separation through reaction*," that is, separation/purification/recovery of a variety of important liquid and solid mixtures have been studied via reacting systems. In 1989–1992, several systems were studied to recover metal values such as boron, gallium, and vanadium from several industrial wastes in which they exist at very low level concentration in the mixtures of high concentration of less desirable species such as aluminum, iron, and silicon. In the term of the present author, the purification process using functional chemical reaction and liquid–liquid extraction has been challenged. The present work has been carried out to purify the liquid hydrocarbon mixtures, that is, to remove objectionable species such as sulfur, nitrogen, and heavy metal-containing compounds from the much larger amount of useful species that compose fuel oils. This "*photochemical refining*" process may be an attractive alternative compared to the established "*hydrotreating*" processes.

Chapter I

Desulfurization Behavior of Sulfur-Containing Compounds in an Oil/Water Two-Phase System

Introduction

Sulfur-containing compounds in light oil feedstocks were reported to be classified into three major compound types: dibenzothiophenes (DBTs), benzothiophenes (BTs), and alkylsulfides (Tajima et al., 1993). According to new sulfur specification imposed for commercial light oil (0.05 wt%), several researches, concerning the hydrodesulfurization (HDS) of these sulfur-containing compounds in light oils, have been carried out mainly in the field of catalyst chemistry. Houalla et al. (1980) and Kabe et al. (1992) have found, by several analytical techniques, that alkylsulfides and BTs are adequately desulfurized by the present HDS method, but the DBTs cannot be desulfurized sufficiently. The DBTs, having alkyl substituents on their 4 and/or 6-position, were found to be significantly difficult as compared with the nonsubstituted DBT owing to steric hindrance, thus revealing that these refractory sulfur species make the deep desulfurization more difficult.

The introductory part of the photochemical desulfurization was carried out by the senior student of the present group. The photoreactivity and photodecomposition behavior of DBT, 4-methyl DBT, and 4,6-dimethyl DBT were studied in detail by photoirradiation of entire wavelength region of light from high-pressure mercury lamp, using an oil/water two-phase system (Ogawa, 1996; Hirai et al., 1996). The latter two refractory sulfur compounds, in the HDS process, were found to be photodecomposed more easily than nonsubstituted DBT by this photochemical process. The desulfurization of actual light oil, however, was significantly suppressed by the presence of large amount of bicyclic aromatic hydrocarbons such as naphthalene.

In this chapter, the photoreactivity and photodecomposition behavior of the other sulfur-containing compounds, alkylsulfides and BT, from tetradecane solution (model light oil) have been studied in detail, using an oil/water two-phase system. The effect of the addition of naphthalene on their photodecomposition is also studied, and the results obtained are compared with those obtained for DBT. The refractory sulfur-containing

Table 1-1. The Properties and Composition of the Light Oils

	commercial light oil (CLO)	straight-run light gas oil (LGO)	light cycle oil (LCO)
density (288 K) (g/mL)	0.8313	0.8548	0.8830
sulfur content (wt%)	0.202	1.434	0.132
saturated fraction (vol%)	76.2	75.4	33.7
aromatics* (vol%)			
monocyclic	19.5	14.9	36.4
bicyclic	4.3	9.7	29.9

*Quantities of tricyclic and higher polycyclic aromatics are trace (<1%)

compounds in light oils is determined. To improve the photoreactivity of refractory sulfur-containing compounds, the effect of the addition of benzophenone (BZP), a triplet photosensitizer to the light oil phase, is then studied.

Experimental Section

1. Materials

DBT, BT, dibutylsulfide (DBS), dibutyldisulfide (DBDS), diphenylsulfide (DPS), benzophenone (BZP), tetradecane ($n\text{-C}_{14}\text{H}_{30}$), and naphthalene were supplied by Wako Pure Chemical Industries, Ltd. and were used without further purification. The n -tetradecane solutions, containing each sulfur-containing compound, were used as model light oil. Commercial light oil (CLO) containing ca. 0.2 wt% sulfur, which agree with the previous regulatory value in Japan, straight-run light gas oil (LGO), and light cycle oil (LCO), supplied from Cosmo Petroleum Institute, were used as feedstocks. The LCO is produced by the fluid catalytic-cracking unit from vacuum gas oil, as shown in **Figure 1**. Relevant properties of these materials are summarized in **Table 1-1**.

2. Apparatus and Procedure

The model or actual light oil (100 mL) was mixed vigorously with distilled water (300 mL), using a magnetic stirrer, in reaction vessel (capacity, 700 mL), and were photoirradiated by an immersion of a high-pressure mercury lamp (300 W, Eikohsha Co., Ltd., Osaka) into the solution with air bubbling (500 mL/min) at atmospheric pressure.

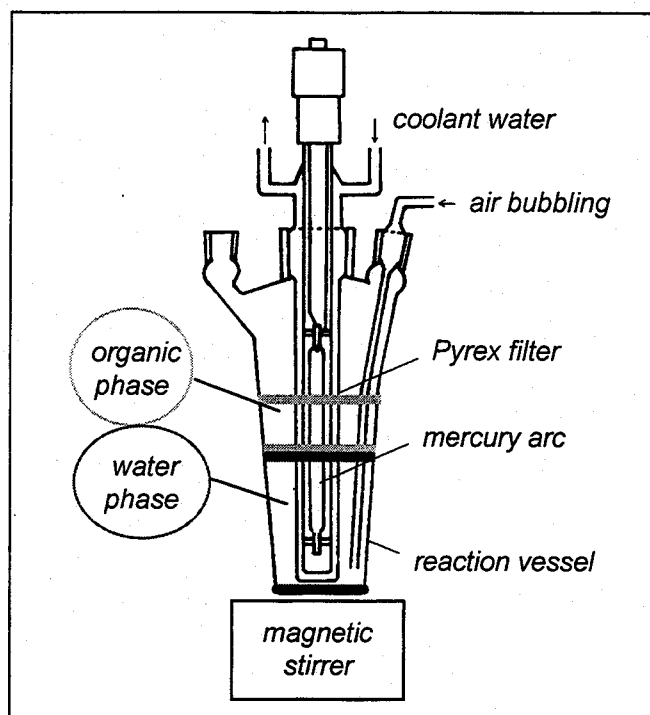

Figure 1-1. Schematic representation of the experimental photoreactor (high-pressure mercury lamp, 300 W). Capacity, 700 mL.

The photoreaction instrument is represented in **Figure 1-1**, and the emission spectrum of the mercury arc is shown in **Figure 1-2**. The main emission peak appears at 366 and 436 nm, and intense peaks present in shorter-wavelength region than 300 nm. A Pyrex glass filter was used to give light wavelengths longer than 280 nm when needed. The temperature of the solution was about 323 K during photoirradiation.

3. Analysis

The concentration of the sulfur-containing compounds in tetradecane was analyzed by gas chromatography (Shimadzu GC-14B equipped with FID). The total sulfur concentration in light oils was measured with an inductively coupled argon plasma atomic emission spectrophotometer (Nippon Jarrell-Ash ICAP-575 Mark II). The quantitative analysis of the individual sulfur-containing compounds in light oils was carried out by a gas chromatography-atomic emission detector (GC-AED, Hewlett Packard 6890, equipped with AED G2350A), and in accordance with the method of Kabe et al. (1992). The concentration of sulfate anion in the water phase was determined by ion chromatography equipped with a conductivity detector (Shimadzu HIC-6A). Separations were performed on a Shim-pack IC-A1 column (Shimadzu), using a buffered aqueous

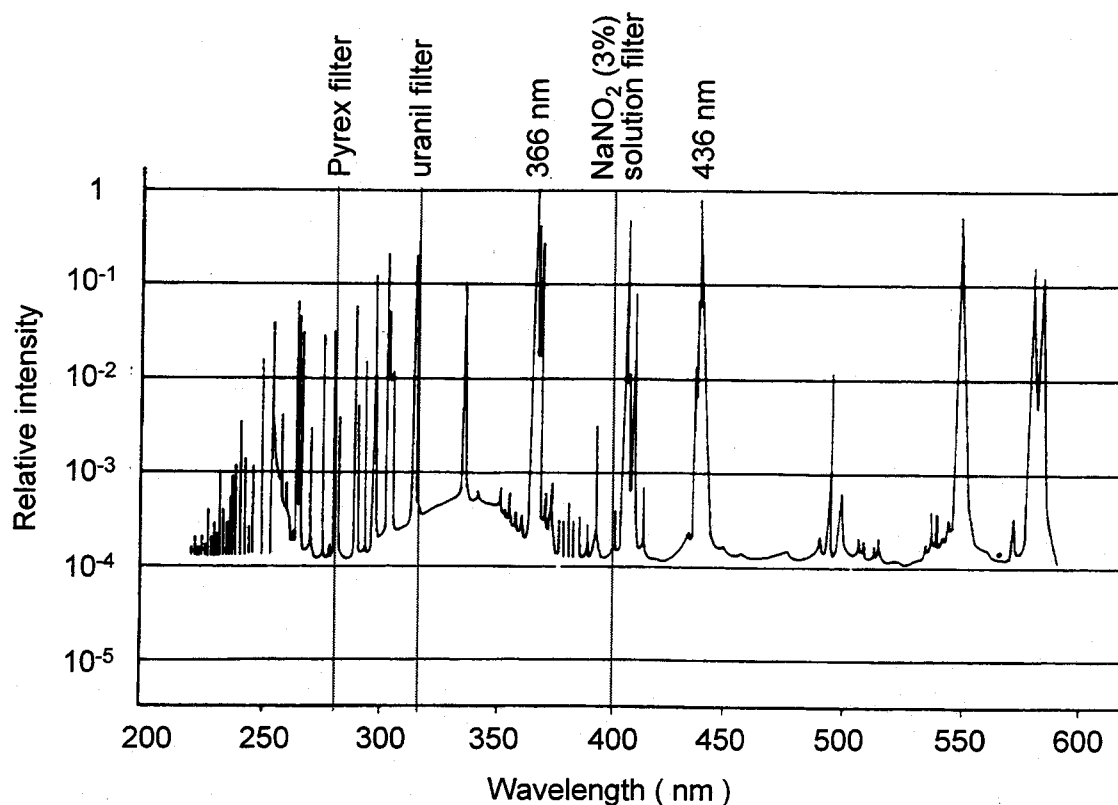

Figure 1-2. Emission spectrum of high-pressure mercury lamp (100 W, 300 W).

solution eluent (pH 7.9), containing mannitol (18 mM), boric acid (6 mM), and Tris (hydroxymethyl)aminomethane (7.5 mM), with a flow rate of 1.5 mL/min. The ion-pair chromatography analysis was performed on reverse-phase HPLC (Shimadzu LC-6A, equipped with a spectrophotometric detector SPD-6A), by an isocratic elution using acetonitrile/water (50/50 v/v) containing tetramethylammonium hydroxide (5 mM) as counterion, with a flow rate of 1.0 mL/min. The composition of light oils was analyzed by normal-phase HPLC equipped with a refractive index detector (Shimadzu LC-6A), by an isocratic elution using *n*-hexane with a flow rate of 1.0 mL/min (JIS-5S-49-97).

Results and Discussion

1. Desulfurization of Sulfur-Containing Compounds

1.1. Removal of Sulfur-Containing Compounds in Tetradecane

GC-AED analyses were carried out to acquire detailed information on the individual sulfur-containing compounds contained in light oils. The sulfur-specific GC-AED chromatograms obtained for light oils are shown in **Figure 1-3**, and the quantities of the

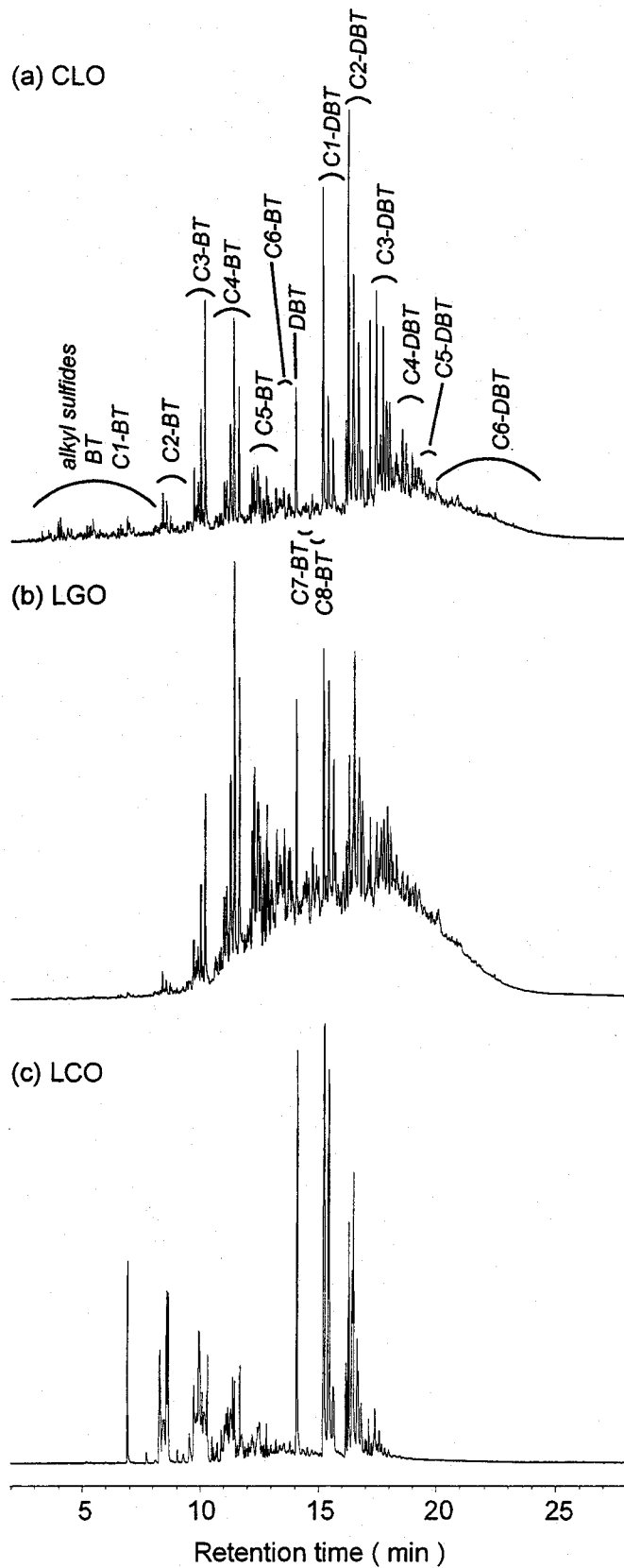

Figure 1-3. Sulfur-specific GC-AED chromatograms (sulfur, 181 nm) for (a) CLO, (b) LGO, and (c) LCO.

Table 1-2. Quantities of Sulfur-Containing Compounds Remaining in Three Light Oils (i) before and (ii) after 36 h Photoirradiation, Using Entire Wavelength Region of Light from High-Pressure Mercury Lamp in Oil/Water Two-Phase Systems

carbon number of substituent	CLO		LGO		LCO	
	(i) (wt%)	(ii) (wt%)	(i) (wt%)	(ii) (wt%)	(i) (wt%)	(ii) (wt%)
< C1-BT*	0.00429	0.00013	0.02519	0.00134	0.01435	0.01192
C2-BT	0.00502	0.00242	0.03356	0.01578	0.01472	0.01245
C3-BT	0.01145	0.00422	0.11998	0.04721	0.01350	0.01107
C4-BT	0.01120	0.00451	0.13853	0.06257	0.00789	0.00759
C5-BT	0.00704	0.00304	0.08198	0.04174	0.00359	0.00347
C6-BT	0.01220	0.00595	0.12952	0.08456	0.00417	0.00419
C7-BT	0.00203	0.00104	0.01702	0.01242	0.00203	0.00210
C8-BT	0.00425	0.00227	0.03988	0.03085	0.00115	0.00123
BTs (total)	0.05748	0.02358	0.58566	0.29657	0.06140	0.05402
DBT	0.00395	0.00264	0.03386	0.02656	0.00839	0.00965
C1-DBT	0.01254	0.01069	0.09691	0.08073	0.02428	0.02671
C2-DBT	0.02371	0.02180	0.14895	0.13679	0.02233	0.02501
C3-DBT	0.02486	0.02332	0.14965	0.14076	0.00636	0.00754
C4-DBT	0.01545	0.01503	0.09405	0.09350	0.00165	0.00185
C5-DBT	0.00452	0.00460	0.02769	0.02714	0.00037	0.00044
C6-DBT	0.05949	0.06332	0.29723	0.30466	0.00722	0.00865
DBTs (total)	0.14452	0.14140	0.84834	0.81014	0.07060	0.07985
Total sulfur	0.20200	0.16493	1.43400	1.10671	0.13200	0.13387

*<C1-BT contains also nonsubstituted BT and alkyl and arylsulfides

sulfur-containing compounds, as determined by GC-MS, are summarized in **Table 1-2**. From these analyses, all light oils were found to contain a considerable amount of DBTs and BTs, and a trace amount of alkylsulfides. The DBTs and BTs, having alkyl substituents of carbon number of C1–C6 and C1–C8, presented mainly in all the light oils, with the DBTs being contained in a larger amount than BTs.

Three kind of alkylsulfides (dibutylsulfide, dibutyldisulfide, and diphenylsulfide), BT, and DBT were each dissolved in tetradecane. These were then photoirradiated using entire wavelength region of light, in the presence of water phase, under air bubbling. **Figure 1-4** shows the time-course variation in the concentrations of sulfur compounds in

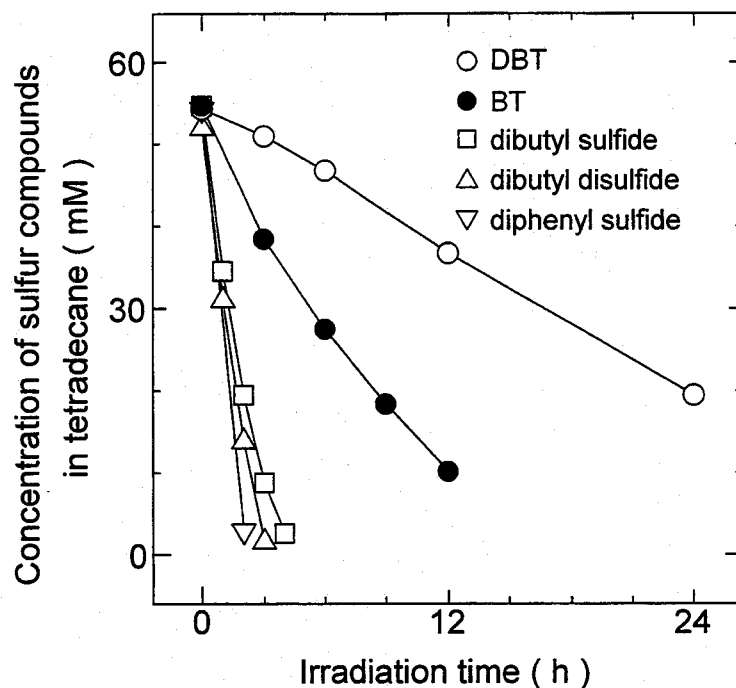

Figure 1-4. Time-course variation in the concentration of sulfur-containing compounds in tetradecane during photoirradiation of the tetradecane/water two-phase system.

tetradecane during photoirradiation, where the data for DBT are cited from previous paper (Hirai et al., 1996). The initial concentration of sulfur compounds (54 mM) corresponds to a sulfur content of 0.2 wt%. The removal of all the sulfur-containing compounds was found to be facilitated by the supply of O_2 by air bubbling. Alkylsulfides and BT were found to be easily photodecomposed in tetradecane as compared with DBT, with a ranking order of alkylsulfides > BT > DBT. The order of reactivity is consistent with those obtained by sunlight photoirradiation of the aqueous solution, as reported by Jacquot et al. (1996) and Mill et al. (1981). These results demonstrate that DBT is the most difficult compound to be desulfurized by the present process.

The DBTs, photodecomposed in tetradecane, is reported to be successively removed into the water phase as SO_4^{2-} anion, via the formation of a third (emulsion) phase (Hirai et al., 1996). All the alkylsulfides was found to be quantitatively removed into the water phase as also SO_4^{2-} anion. This result is consistent with those obtained by the photoirradiation of 254 nm from medium-pressure mercury lamp in aqueous solution (Banchereau et al., 1997). During photoirradiation of tetradecane/water two phases for BT, an emulsion phase first appeared between the two phases. This then disappeared by

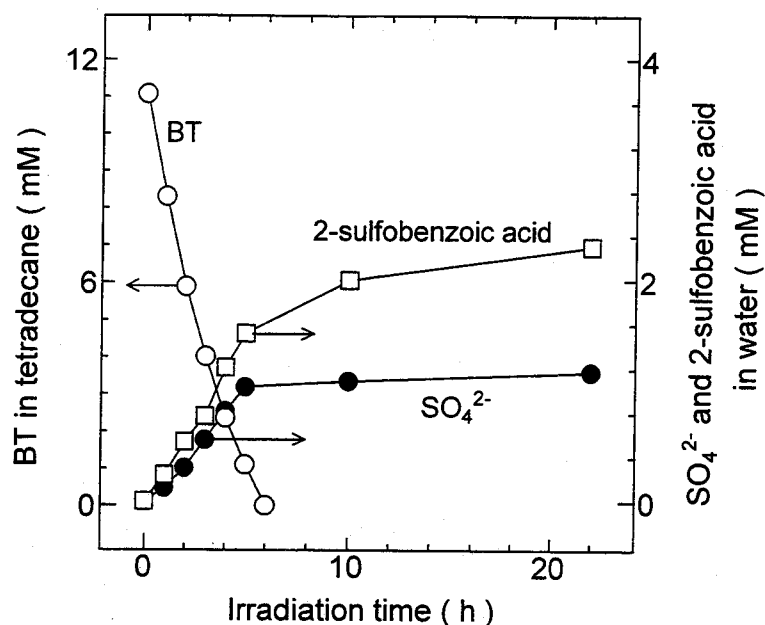

Figure 1-5. Time-course variation in the concentration of BT in tetradecane phase and sulfate anion and sulfobenzoic acid in water phase.

further photoirradiation, as in the case of DBT. This indicates that the BT is first photodecomposed in tetradecane to form intermediates, having surface activity, which are then removed into the water phase by further photodecomposition. The tetradecane phase, following the photoirradiation, was found by GC-AED analysis to contain only unreacted BT as the sulfur-containing compounds. Ion chromatography analysis of the resulting water phase showed that 35% of sulfur removed into the water phase was found to appear as SO_4^{2-} anion, as shown in **Figure 1-5**. By the analysis of ion-pair chromatography, the remaining sulfur-containing compound in water phase was found to appear as 2-sulfobenzoic acid. Andersson and Bobinger (1992) have reported that the photoirradiation ($\lambda > 300 \text{ nm}$) by medium-pressure mercury lamp to the BT, dissolved in water, gives rise to only 2-sulfobenzoic acid, without the formation of SO_4^{2-} anion. This is probably caused by the difference in the wavelength range of the light sources.

1.2. Removal of Sulfur-Containing Compounds in the Presence of Naphthalene

The removal of DBT from tetradecane was reported to be depressed significantly by the presence of naphthalene (Hirai et al., 1996). This is a serious problem for desulfurization of light oils, since the light oils contain a considerable amount of bicyclic aromatic hydrocarbons, as shown in **Table 1-1**. The photoreactivity of alkylsulfides and BT in the presence of naphthalene was then investigated, and the results are shown in

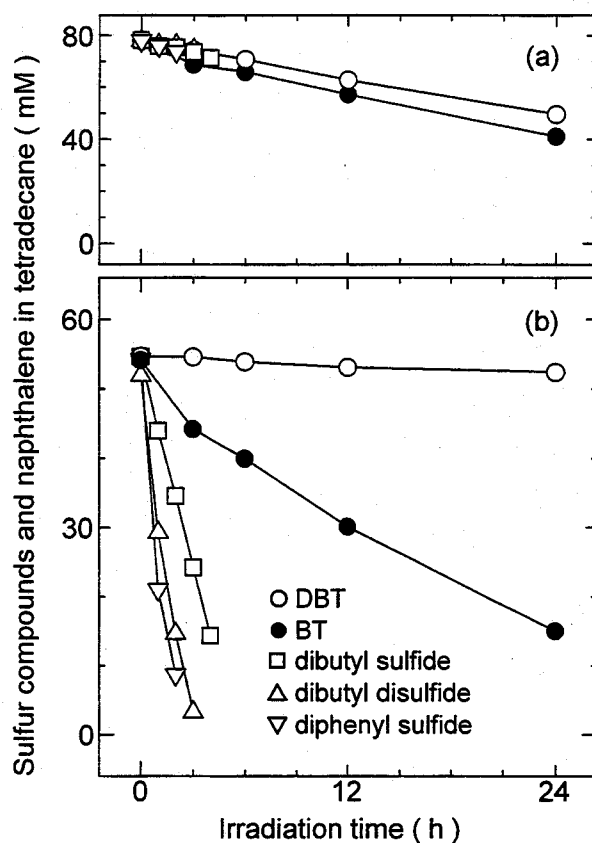

Figure 1-6. Time-course variation in the concentration of (a) naphthalene and (b) sulfur-containing compounds in tetradecane, during photoirradiation of tetradecane/water two-phase system.

Figure 1-6. The initial naphthalene concentration (78 mM) corresponds to 1.3 vol%, which is much less as compared to the bicyclic aromatic content of commercial light oil (4.3 vol%), as shown in **Table 1-1**. Although the removal of DBT was significantly suppressed by the presence of naphthalene, the removal of alkylsulfides and BT was still found to proceed effectively. In this case, significant amount of naphthalene was also photodecomposed.

The desulfurization of actual light oils, having different aromatic content, was then investigated to know the effect of the aromatics on the desulfurization of light oils in detail. The concentration of bicyclic aromatics in light oils is 4.3 vol% for commercial light oil (CLO), 9.7 vol% for straight-run light gas oil (LGO), and 29.9 vol% for light cycle oil (LCO), as shown in **Table 1-1**. The time-course variation in the concentration of total sulfur, BTs, and DBTs in CLO is shown in **Figure 1-7**, and the concentration of the individual sulfur-containing compounds remaining in light oils, following 36 h photoirradiation, is summarized in **Table 1-2**. The total sulfur content of CLO decreased

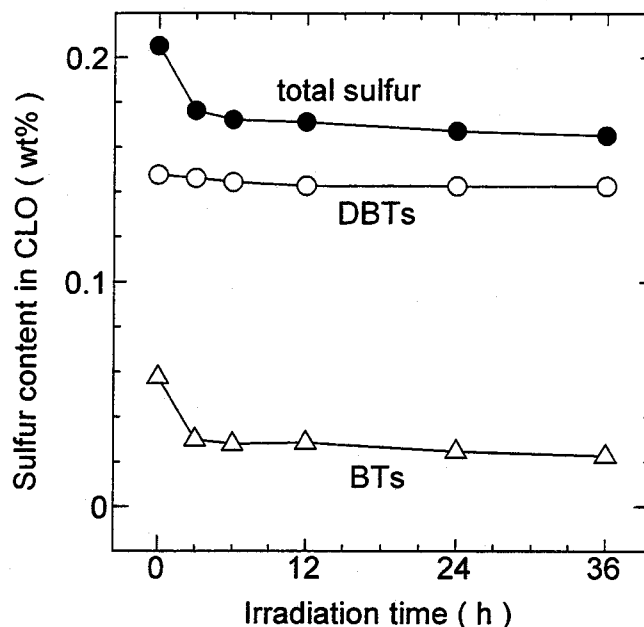

Figure 1-7. Time-course variation in the concentration of total sulfur, BTs, and DBTs in CLO during photoirradiation of CLO/water two-phase system.

rapidly at first, but the rate became slowly with photoirradiation time, as shown in **Figure 1-7**. Although the BTs concentration was reduced in the initial part of the photoirradiation, no reduction in the DBTs concentration was observed at all. The desulfurization yield for light oils, following 36 h photoirradiation, was 22% for CLO and 23% for LGO. The yield for LGO was slightly higher than for CLO, although the LGO contains a higher bicyclic aromatics content than CLO. This is because the LGO contains a 10-fold greater quantity of BTs as compared with CLO; hence, these are much more easily photodecomposed. The apparent residual percentage of sulfur in LCO was seen to increase up to 115%. This is because the total volume of LCO was reduced by the photodegradation of the aromatic hydrocarbons, which absorb the short-wavelength UV light.

The desulfurization yields for DBTs, following 36 h photoirradiation, were 7% for CLO and 5% for LGO, and 0% for LCO. The desulfurization yields of BTs were greater than those for the DBTs in all the light oils; 61% for CLO, 49% for LGO, and 12% for LCO, respectively. From these results, it was found, by the present photochemical process, that the BTs are relatively easily desulfurized, but the desulfurization of DBTs from aromatic rich light oils is significantly difficult. The photodecomposition of DBTs

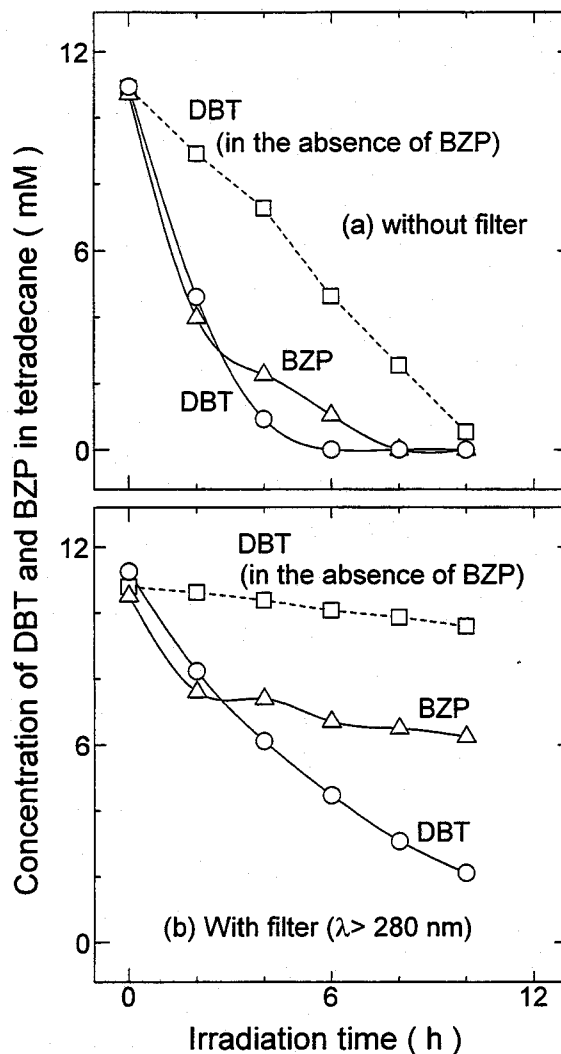

Figure 1-8. Time-course variation in the concentrations of DBT and BZP in tetradecane in the cases without filter (a) and with filter (b).

must therefore be accelerated, and the photodecomposition of aromatic hydrocarbons must be suppressed.

2. Effect of Triplet Photosensitizer on Desulfurization

2.1. Removal of DBT from Tetradecane

The quantum yield of excited triplet state formation of DBT is estimated as 0.97 (Murov et al., 1993). This high yield indicates that the photoreaction of DBT with molecular oxygen proceeds predominantly via triplet excitation state of DBT. Benzophenone (BZP), a triplet photosensitizer, of which the quantum yield of triplet state formation is 1.00 and the triplet energy is 287 kJ/mol (Murov et al., 1993). The triplet

Table 1-3. Effect of the Addition of Triplet Photosensitizers on the Removal of DBT from Tetradecane in an Oil/Water Two-Phase System (irradiation time, 10h; $\lambda > 280$ nm; $[\text{DBT}]_{\text{initial}} = 11$ mM; $[\text{photosensitizer}]_{\text{initial}} = 11$ mM)

triplet photosensitizer	$E_S^{*,a}$ (kJ/mol)	$E_T^{*,b}$ (kJ/mol)	$\phi_T^{*,c}$ (-)	$\tau_T^{*,d}$ (μs)	desulfurization (%)
(no addition)					7.90
acetophenone	330	310	1	0.23	14.8
benzaldehyde	323	301			52.8
benzophenone (BZP)	316	287	1	6.9	81.2
1-indanone	331	314			19.1
4-methoxyacetophenone	340	300	1		8.89
4,4'-dimethoxybenzophenone	328	293	1	3.6	27.9
propiophenone	336	312			16.9
4,4'-dimethylbenzophenone	324	288		11	74.9
4-methoxybenzophenone		287	1	7.2	27.9
4-phenylbenzophenone	321	254			
DBT	367	285	0.97		
naphthalene	385	253	0.75	175	

* Murov et al., (1993); ^a singlet excitation energy; ^b triplet excitation energy; ^c quantum yield of triplet state formation; ^d triplet excitation state life time.

energy of DBT is estimated as 285 kJ/mol, and the energy transfer to DBT from the photoexcited BZP is therefore expected to occur efficiently. To excite BZP to the triplet state via the excited singlet state, the excitation energy of 315 kJ/mol is required, which corresponds to light wavelength of 380 nm. Since the DBT is photoexcited by the irradiation at wavelength of $\lambda < 325$ nm (Murov et al., 1993), the DBT might be photoexcited at longer wavelength region of light (lower energy) by the addition of BZP. The direct photodecomposition of aromatic hydrocarbons is thereby expected to be suppressed. The effect of the addition of BZP on the desulfurization of DBT was therefore studied.

Figure 1-8 shows the time-course variation in the concentrations of DBT and BZP in tetradecane, under photoirradiation with and without a Pyrex glass filter ($\lambda > 280$ nm). The removal of DBT was much enhanced by the addition of BZP in both cases. This photosensitization reaction can be expressed as:

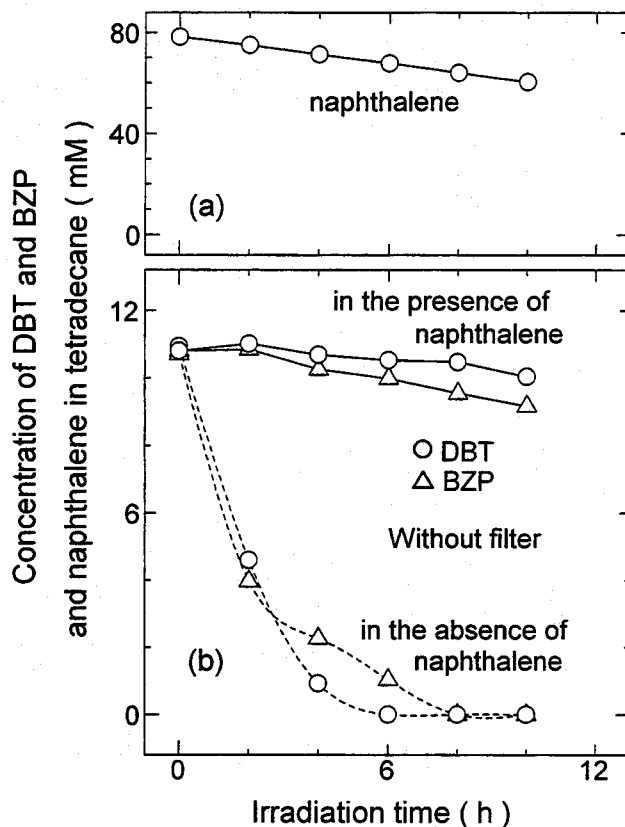

Figure 1-9. Time-course variation in the concentrations of (a) NP, (b) DBT and BZP in tetradecane in the case without Pyrex filter.



In the case without Pyrex filter, BZP itself was, however, photodecomposed remarkably, as shown in **Figure 1-8a**. With filter, the photodecomposition of BZP was suppressed, while the removal rate of DBT was also decreased, as shown in **Figure 1-8b**. In this case, the effect of the addition of BZP was more noticeable; the amount of removed DBT in the presence of BZP was about 7.6 times as much as that in the absence of BZP following 10 h photoirradiation. Other triplet photosensitizers, of which the triplet energy is higher than that of DBT, were seen not to be effective for the desulfurization of DBT from tetradecane, as shown in **Table 1-3**, thus revealing that BZP is the most effective triplet photosensitizer for the photoexcitation of DBT.

2.2. Removal of DBT in the Presence of Naphthalene

The effect of the addition of naphthalene on the removal of DBT from tetradecane, in the presence of BZP, was then studied. The results obtained are shown in **Figure 1-9**. The removal of DBT was, however, suppressed by the presence of naphthalene. The

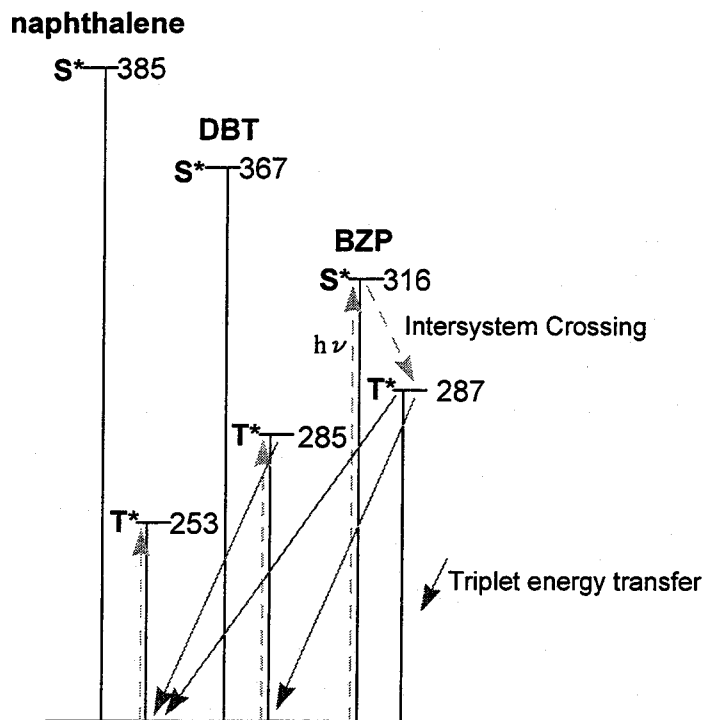

Figure 1-10. Triplet energy transfer occurring between BZP, DBT, and naphthalene (unit, kJ/mol; S*, singlet state; T*, triplet state).

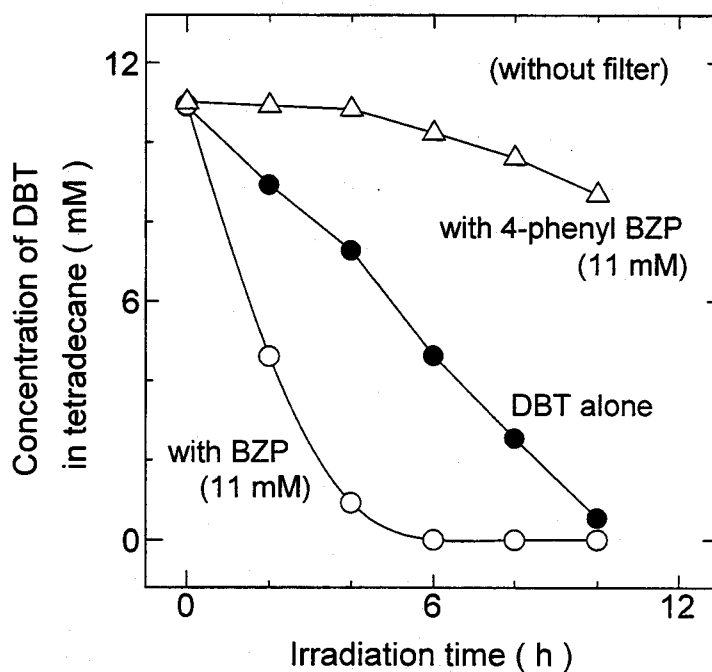

Figure 1-11. Effect of the addition of BZP and 4-phenyl BZP on time-course variation in the DBT concentration in tetradecane in the case without filter.

desulfurization of light oils was still found to be hardly effected by the addition of BZP. This results can be attributed to the triplet energy of naphthalene, 253 kJ/mol, which is lower than that of DBT and BZP, as shown in **Table 1-3**. Thus, the energy transfer from the photoexcited DBT or BZP to the ground-state naphthalene is likely to occur, during photoirradiation, as schematically shown in **Figure 1-10**, and as follows.



The indirectly photoexcited DBT by the photosensitization of BZP is thereby deactivated by naphthalene, thus giving the low photodecomposition yield for DBT. It was confirmed by the experiment using 4-phenyl BZP, a photosensitizer. As shown in **Table 1-3**, the triplet energy for 4-phenyl BZP is 254 kJ/mol, which is lower than that of the DBT. As shown in **Figure 1-11**, the photoreaction of DBT was also suppressed by the addition of 4-phenyl BZP. Therefore, the addition of a triplet photosensitizer is not effective for desulfurization of light oils, containing a large amount of bicyclic aromatics, such as naphthalene. New photochemical processes, which can accelerate the photodecomposition of DBT at its excitation state even in the presence of naphthalene, is therefore, required to improve the photodecomposition yield for DBT.

Summary

The photoreactivity of individual sulfur-containing compounds in light oils has been studied by UV irradiation and liquid-liquid extraction, using an oil/water two-phase system, and the following results obtained.

1) Alkylsulfides and benzothiophene (BT), dissolved in tetradecane (model light oil), were photodecomposed effectively, by the irradiation of entire wavelength region of light from high-pressure mercury lamp, and removed into the water phase, as SO_4^{2-} anion or 2-sulfobenzoic acid. The photodecomposition of these compounds proceeded faster than that of dibenzothiophene (DBT).

2) The removal of DBT from tetradecane was suppressed significantly by the presence of naphthalene, while the photodecomposition of alkylsulfides and BT proceeded effectively. The desulfurization of DBTs from the light oils was significantly difficult,

and the desulfurization yield for light oils was decreased with increasing concentration of bicyclic aromatics. In this photochemical process, significant amount of aromatic hydrocarbons was photodecomposed.

3) The addition of benzophenone (BZP), a triplet photosensitizer, enhanced the removal of DBT from tetradecane. This photosensitizing reaction occurred efficiently by the irradiation of relatively long-wavelength region of light ($\lambda > 280$ nm). This reaction was, however, suppressed significantly by the presence of naphthalene and no acceleration in the desulfurization of DBT was observed, because of the triplet energy transfer from photoexcited DBT or BZP to the ground-state of naphthalene.

Chapter II

Desulfurization of Light Oils by Photooxidation

Using Hydrogen Peroxide in an Oil/Water Two-Phase System

Introduction

In Chapter I, desulfurization of alkylsulfides, BTs and DBTs from the model or actual light oils, has been investigated, based on UV irradiation and liquid-liquid extraction using an oil/water two-phase system. It was demonstrated that removal of DBTs from light oils was depressed markedly by the presence of naphthalene, such that the deep desulfurization of light oils (0.05 wt%) could not be attained by this method. The addition of a triplet photosensitizer (benzophenone: BZP) was not effective for the desulfurization of light oils, since the photoexcited DBTs are deactivated by the triplet energy transfer to the ground-state bicyclic aromatics, such as naphthalene. The improvement of the photoreaction of DBT is necessary to cope with this adverse effect of naphthalene.

Heimlich and Wallace (1966) have reported that DBT, dissolved in paraffinic white oil, is successfully oxidized by 30% hydrogen peroxide, only in the presence of glacial acetic acid, to form corresponding sulfoxide and sulfone, which are insoluble to the oil phase. The H_2O_2 is well known to oxidize the photoexcited organic molecules (Omura and Matsuura, 1968; 1970), and also to be photodecomposed by UV irradiation into the hydroxyl radicals, which act as a strong oxidizing agent for organic compounds (Ingram et al., 1955). If these oxidation reactions occur also in the present oil/water two-phase system, the photodecomposition of DBT and the desulfurization of light oil are expected to be enhanced.

In this chapter, the effect of the addition of H_2O_2 on the desulfurization of light oils has therefore been studied under photoirradiation of entire wavelength region of light, using an oil/water two-phase system. In this process, the H_2O_2 and sulfur-free aromatic hydrocarbons are, however, photodecomposed by the absorption of short-wavelength UV light ($\lambda < 280 \text{ nm}$) (Volman and Chen, 1959), which is necessary for the direct photoexcitation of DBT. In order to suppress these undesirable side reaction, the effect

of the addition of both BZP and H₂O₂ on desulfurization of light oils is then studied under irradiation of relatively long-wavelength light ($\lambda > 280$ nm). A separation process for resulting sulfur-containing compounds from the water phase is also examined, using solid adsorbents.

Experimental Section

1. Materials

In addition to the materials described in Chapter I, H₂O₂ (30% aqueous solution, Wako) was used. 4-Methyl and 4,6-dimethyl DBT were synthesized according to the methods of Gerdil and Lucken (1965) and Kuehm-Caubère et al. (1996). Commercial light oil (CLO) and straight-run light gas oil (LGO), used in Chapter I, were also used as feedstocks, whose properties are summarized in **Table 1-1**. The new CLO, containing 0.18 wt% sulfur, 19.5 vol% monocyclic aromatics, and 17.5 vol% bicyclic aromatics, was also used for photoreaction studies. The tetradecane solution, containing individual sulfur-containing compounds, was used as model light oil. The organic solutions, to which benzophenone (BZP) was added, were also used. Aluminum oxide (surface area = 107.6 m²/g) and activated carbon adsorbents were used, following the activation treatment, to separate the resulting sulfur compounds from the water phase.

2. Apparatus and Procedure

Organic solutions, such as the above feedstocks or model light oils (100 mL), were mixed vigorously with water or aqueous H₂O₂ solution (300 mL) using a magnetic stirrer. These were photoirradiated by the immersion of a high-pressure mercury lamp (300 W, Eikohsha Co., Ltd., Osaka), and with air bubbling (500 mL/min) at atmospheric pressure. A Pyrex glass filter was used to give a light wavelength rejection of less than 280 nm.

3. Analysis

The full procedure was described in Chapter I, and only a brief description is presented here. The concentration of DBTs, BT, or BZP in tetradecane was analyzed by a gas chromatography (GC-FID, Shimadzu). The concentrations of H₂O₂ in the water phase and hydroperoxide in light oils were determined by a titrimetric analysis using sodium thiosulfate and potassium iodide as an indicator (Hendry et al., 1976).

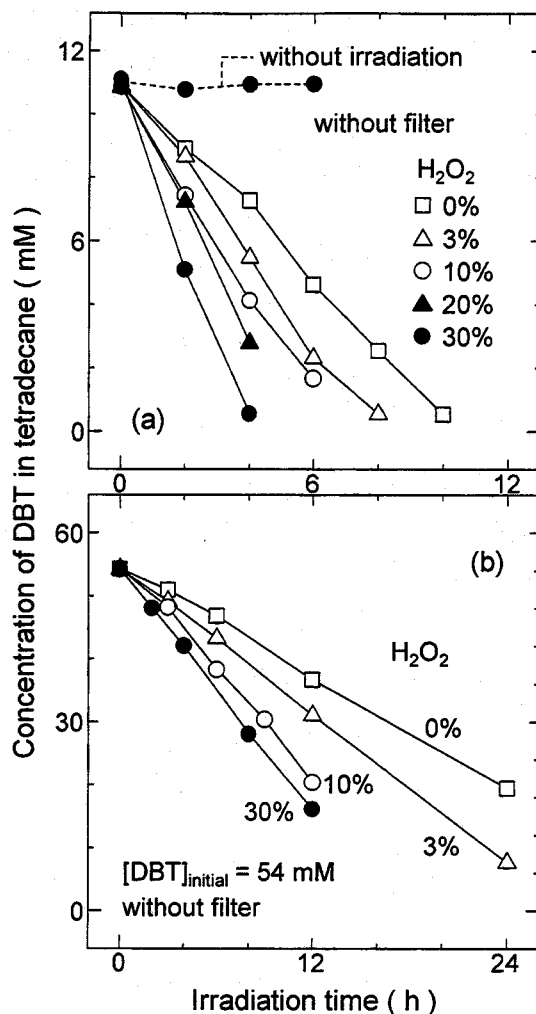

Figure 2-1. Effect of addition of H₂O₂ on time-course variation of DBT concentration in tetradecane in the case without Pyrex filter. Initial DBT concentration: (a) 11 mM and (b) 54 mM.

Results and Discussion

1. Effect of the Addition of Hydrogen Peroxide on Desulfurization

1.1. Removal of DBT from Tetradecane in the Presence of Hydrogen Peroxide

Figure 2-1 shows the time-course variation in the concentration of DBT in tetradecane, during photoirradiation of the tetradecane/water two-phase system, as a function of H₂O₂ concentration in the water phase. The removal of DBT from tetradecane was found to be enhanced by the addition of hydrogen peroxide, and was accelerated with an increase in the H₂O₂ concentration. The addition of H₂O₂ also decreases the aqueous phase pH. The pH value of 30% H₂O₂ solution is about 2.5. The pH-effect for the removal of DBT, however, can be negligible, since the reaction was

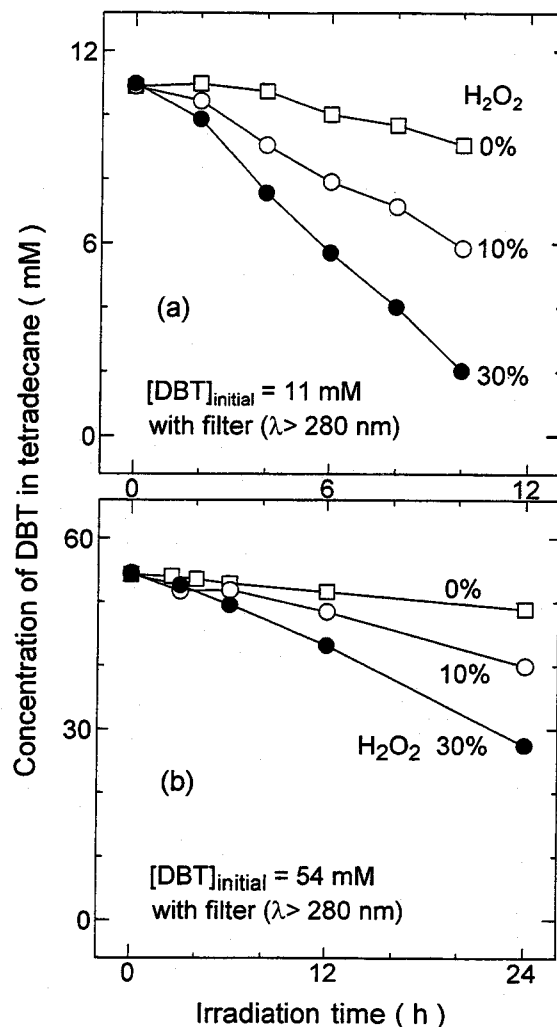

Figure 2-2. Effect of addition of H₂O₂ on time-course variation of DBT concentration in tetradecane in the case with Pyrex filter ($\lambda > 280$ nm). Initial DBT concentration: (a) 11 mM and (b) 54 mM.

found not to be enhanced by decreasing the pH value by the addition of HCl solution. During the photoirradiation of the tetradecane/water two phases, a third (emulsion) phase appeared between the two phases, as in the case without H₂O₂ (Hirai et al., 1996). This then disappeared during the course of photoirradiation, thus indicating the formation of intermediates having surface activity. The photodecomposed DBT was found, by ion chromatography analysis, to be converted to SO₄²⁻.

Addition of H₂O₂ may have two effects on the photoreaction of DBT. One is the effect of the hydroxyl radical, produced by photodecomposition of H₂O₂, as below.





The other is the effect as a weak oxidizing agent, which oxidize the photoexcited DBT molecule before deactivation, as below:



As shown in **Figure 2-2**, the addition of H_2O_2 also enhanced the removal of DBT in the case with Pyrex filter ($\lambda > 280 \text{ nm}$). This indicates that the latter effect of H_2O_2 is dominant in the present system, since the H_2O_2 is hardly photodecomposed into hydroxyl radicals at wavelengths of $\lambda > 280 \text{ nm}$. On the other hand, no photoreaction of DBT was observed under photoirradiation at wavelengths of $\lambda > 325 \text{ nm}$, regardless of the presence of H_2O_2 , since the wavelength, corresponding to the lowest singlet excitation energy of DBT (367 kJ/mol), was 325.9 nm and thus DBT was hardly photoexcited (Murov et al., 1993). These findings support the proposed mechanism; H_2O_2 itself does not directly oxidize the DBT, but helps the photoexcited DBT to be oxidized, as shown by Eq. (2-3) and (2-4). A similar photoreaction mechanism was proposed by Omura and Matsuura (1968; 1970) for the case of hydroxylation of phenols by the light of 280 nm in the presence of H_2O_2 . In addition, they also proposed that the photoexcited phenol may transfer its excited energy to a H_2O_2 molecule to give hydroxyl radicals. This kind of reaction may occur in the present two-phase system.

The removal rate of DBT from tetradecane was increased with H_2O_2 concentration as shown in **Figure 2-3**, since the greater H_2O_2 concentration enhanced the contact of photoexcited DBT with H_2O_2 . However, the degree of increase in the case using Pyrex filter is slightly smaller than the case without filter. This difference between the two cases can be attributed to the reaction of DBT with hydroxyl radical generated by direct photodecomposition of H_2O_2 . On the other hand, the removal rate was found to be much faster when the initial DBT concentration was increased to 54 mM. In this case, the amount of DBT molecule photoexcited by UV irradiation is much greater than that in the case $[\text{DBT}]_{\text{initial}} = 11 \text{ mM}$, except for the case using Pyrex filter. The removal of the photoexcited DBT is enhanced by contacting with H_2O_2 molecule in the water phase; otherwise a certain amount of the excited DBT is deactivated. The removal rate, at

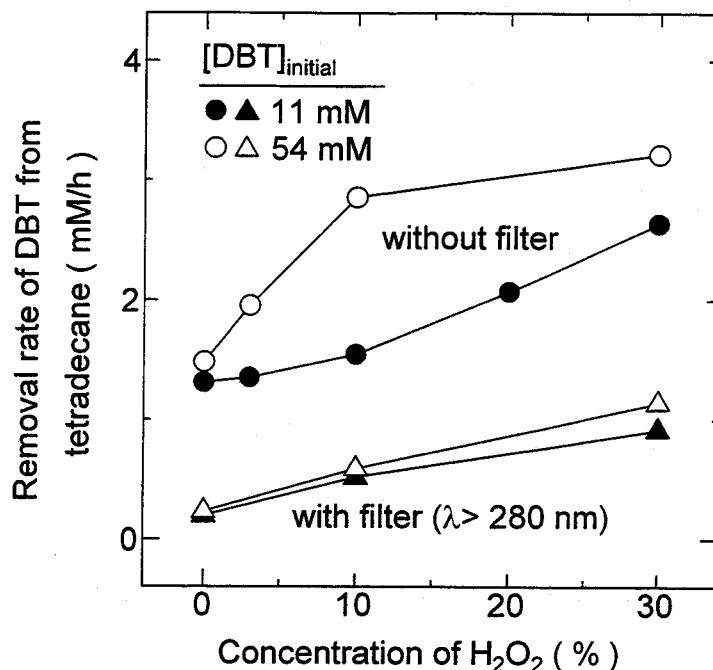

Figure 2-3. Relationship between concentration of H₂O₂ and removal rate of DBT from tetradecane in the cases with and without Pyrex filter.

[DBT]_{initial} = 54 mM, increased with H₂O₂ concentration linearly at H₂O₂ concentrations up to 10%. At [H₂O₂] = 30%, however, the removal rate was not so enhanced compared with that obtained at [H₂O₂] = 10%. Under this condition, the photoexcitation of DBT can be the rate determining step, while the concentration of H₂O₂ is great enough. At [H₂O₂] = 0%, in contrast, the possible rate determining step is the contact of excited DBT with O₂ dissolved in the organic and water phases. The finding that the removal rate is independent of the DBT concentration at [H₂O₂] = 0% probably shows that the O₂ concentration governs the removal rate of DBT in this condition.

1.2. Photoreactivity of Methyl-Substituted DBTs and Benzothiophene, and the Effect of Naphthalene on the Desulfurization of DBT

Methyl-substituted DBTs and BTs are main constituents of the sulfur-containing compounds in light oils, as described in Chapter I. The photoreactivity of these compounds in the presence of H₂O₂ was therefore also studied. The removal rate of DBTs from tetradecane increased with increasing the carbon number of the methyl substituent, with the order of 4,6-dimethyl DBT > 4-methyl DBT > DBT, as shown in **Figure 2-4**. In the absence of H₂O₂, similar tendency was observed (Hirai et al., 1996).

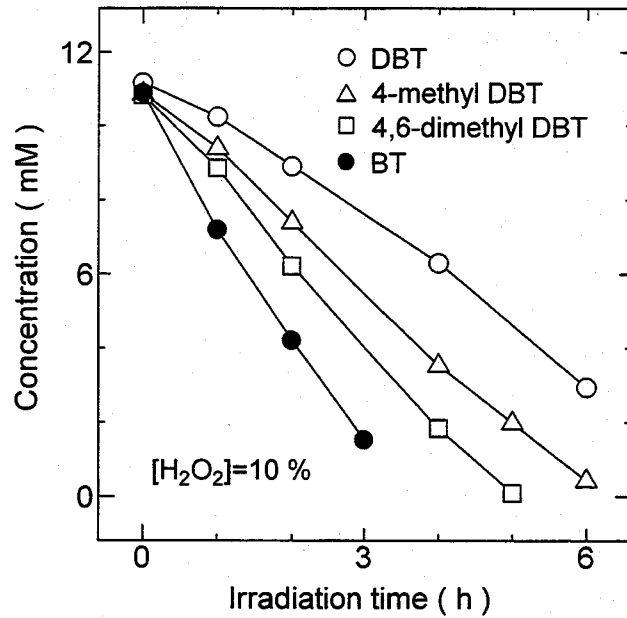

Figure 2-4. Time-course variation in the concentration of DBTs and BT, during photoirradiation of the tetradecane/water two-phase system. $[H_2O_2] = 10\%$.

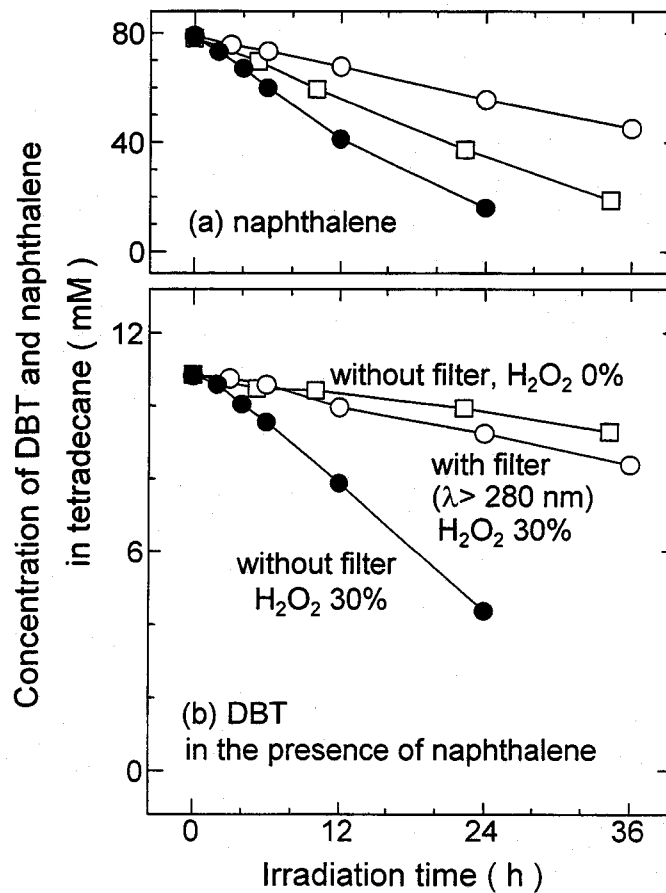

Figure 2-5. Time-course variation in the concentrations of (a) naphthalene and (b) DBT in tetradecane in the cases without filter ($[H_2O_2] = 0\%$ or 30%) and with Pyrex filter ($\lambda > 280$ nm, $[H_2O_2] = 30\%$).

In the current hydrodesulfurization (HDS) method, these methyl-substituted DBTs are the most difficult compounds to be desulfurized, thus indicating that the present method is effective for the desulfurization of these refractory compounds. The photodecomposition rate of BTs was found to be much faster than that of DBTs, as in the case without H₂O₂ (Chapter I), and the rate was increased with an increase in the H₂O₂ concentration.

The addition of 30% H₂O₂ enhanced the removal of DBT from tetradecane, even in the presence of naphthalene, as shown in **Figure 2-5**. Although the energy transfer from the photoexcited DBT to the ground-state naphthalene was found to occur since the removal rate of DBT was decreased as compared to that in the absence of naphthalene, the energy transfer was suppressed significantly by the addition of H₂O₂. In this case, photodecomposition of naphthalene was also enhanced by the addition of H₂O₂, thus indicating that H₂O₂ had a similar effect for naphthalene as for DBT. In the case with Pyrex filter, the removal of DBT was only slightly enhanced by 30% H₂O₂, while the removal of naphthalene was much suppressed. The direct photodecomposition of naphthalene as well as photoexcitation of DBT by UV irradiation were suppressed by using the filter ($\lambda > 280$ nm).

1.3. Desulfurization of Light Oils in the Presence of Hydrogen Peroxide

Figure 2-6 shows the time-course variation in the total sulfur content of three light oils, with respect to H₂O₂ concentration in water phase, during photoirradiation without use of a Pyrex filter. The desulfurization of commercial light oil (CLO) was much enhanced by the addition of H₂O₂, and the sulfur content was decreased successfully from 0.2 wt% to less than 0.02 wt%, at a 30% H₂O₂ concentration and 36 h photoirradiation (**Figure 2-6a**). This sulfur content value of 0.02 wt% is below the regulatory value for light oil (0.05 wt%), thus indicating that the proposed desulfurization method is, therefore, effective for deep desulfurization of CLO.

The present process was also effective for the desulfurization of other light oils, straight-run light gas oil (LGO) and light cycle oil (LCO), having higher bicyclic aromatic content than for the CLO. As shown in **Figure 2-6b**, the desulfurization of LGO was accelerated with increasing the H₂O₂ concentration, as in the case for CLO. The sulfur content was reduced, from 1.434 wt% to 0.335 wt%, by 36 h photoirradiation at a 30% H₂O₂ concentration. The quantity of sulfur removed from the LGO was six-fold

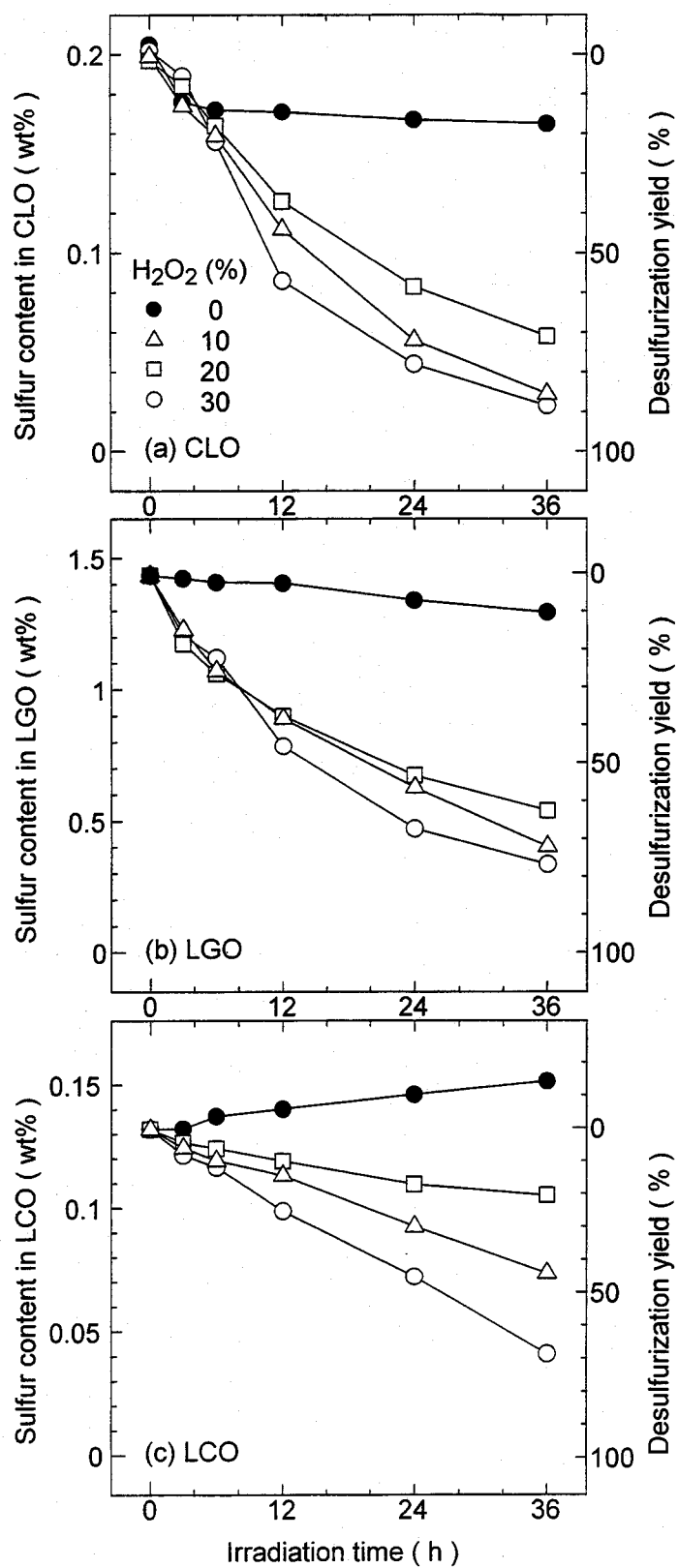

Figure 2-6. Time-course variation in the sulfur contents of (a) CLO, (b) LGO, and (c) LCO with respect to H₂O₂ concentration in water phase.

greater than that obtained for CLO. For LCO, as shown in **Figure 2-6c**, desulfurization rate was much slower than those obtained for both CLO and LGO, because the LCO contains a higher proportion of bicyclic aromatic hydrocarbons, as shown in **Table 1-1**. The desulfurization rate was found to be still accelerated with increasing H_2O_2 concentration, and 62% of the sulfur was removed, at a 30% H_2O_2 concentration and 36 h photoirradiation. Although the quantity of sulfur removed from LCO was about half as much as that from CLO, the sulfur content was successfully reduced to less than 0.05 wt%. The proposed process is thus also effective for desulfurization for aromatic rich light oils. The recoveries of light oils, following desulfurization, was however found to be reduced with increasing the aromatic content of light oils; 91% for CLO, 90% for LGO, and 78% for LCO at a 30% H_2O_2 concentration and 36 h photoirradiation. This is because the aromatic hydrocarbons in light oils are also photodecomposed by the irradiation of short-wavelength UV light and the oxidation by H_2O_2 .

1.4. Reactivities of Sulfur-Containing Compounds in Light Oils

It is necessary to know the reactivities of individual sulfur-containing compounds in light oils. The light oils, following desulfurization, were analyzed by GC-AED, and the quantities of the sulfur-containing compounds remaining in the desulfurized light oils were determined. The results are listed in **Table 2-1**. The BTs in each light oil are desulfurized more easily than DBTs. Ninety-nine percent of BTs in CLO and LGO and 95% of those in LCO is desulfurized. The quantity of BTs desulfurized from LGO is ten-fold greater as compared with that from CLO, thus indicating that the present process is effective for desulfurization of light oils containing a large quantity of BTs. The DBTs in CLO and LGO are also desulfurized effectively, and desulfurization is 88% and 79%, respectively. However, only 53% of DBTs in LCO are desulfurized, and in particular, C4–C6 DBTs decreased only slightly.

Figure 2-7 shows the remaining percentage values for BTs and DBTs in light oils, following 36 h photoirradiation, as a function of H_2O_2 concentration. The BTs and DBTs in CLO and LGO are desulfurized effectively by increasing the H_2O_2 concentration, although the remaining percentage increases with increasing carbon number of substituent, especially for DBTs. Desulfurization is not so easy for the highly-substituted BTs and

Table 2-1. Quantities of Sulfur-Containing Compounds Remaining in Three Light Oils (i) before and (ii) after 36 h Photoirradiation, Using Entire Wavelength Region of Light from High-Pressure Mercury Lamp in an Oil/H₂O₂ (30% Aqueous Solution) Two-Phase Systems

carbon number of substituent	CLO		LGO		LCO	
	(i) (wt%)	(ii) (wt%)	(i) (wt%)	(ii) (wt%)	(i) (wt%)	(ii) (wt%)
< C1-BT*	0.00429	0	0.02519	0	0.01435	0
C2-BT	0.00502	0	0.03356	0	0.01472	0
C3-BT	0.01145	0.00003	0.11998	0	0.01350	0
C4-BT	0.01120	0.00006	0.13853	0	0.00789	0.00018
C5-BT	0.00704	0.00004	0.08198	0	0.00359	0.00033
C6-BT	0.01220	0.00019	0.12952	0.00262	0.00417	0.00122
C7-BT	0.00203	0.00005	0.01702	0.00106	0.00203	0.00078
C8-BT	0.00425	0.00016	0.03988	0.00393	0.00115	0.00069
BTs (total)	0.05748	0.00053	0.58566	0.00761	0.06140	0.00320
DBT	0.00395	0.00003	0.03386	0.00018	0.00839	0.00176
C1-DBT	0.01254	0.00019	0.09691	0.00433	0.02428	0.00517
C2-DBT	0.02371	0.00058	0.14895	0.01479	0.02233	0.00836
C3-DBT	0.02486	0.00113	0.14965	0.02355	0.00636	0.00497
C4-DBT	0.01545	0.00118	0.09405	0.01978	0.00165	0.00153
C5-DBT	0.00452	0.00082	0.02769	0.00882	0.00037	0.00037
C6-DBT	0.05949	0.01684	0.29723	0.17595	0.00722	0.00718
DBTs (total)	0.14452	0.02077	0.84834	0.24740	0.07060	0.03254
Total sulfur	0.20200	0.02130	1.43400	0.25501	0.13200	0.04090

*<C1-BT contains also nonsubstituted BT and alkyl and arylsulfides.

DBTs in LCO. The BTs and C0–C3 DBTs in LCO are desulfurized fairly effectively by the addition of H₂O₂. The C4–C6 DBTs are however hardly desulfurized, thus demonstrating that the proposed process has difficulty in the desulfurization of highly-substituted DBTs.

2. Effect of the Both Addition of Triplet Photosensitizer and Hydrogen Peroxide on Desulfurization

2.1. Effect on Desulfurization of DBT and Decomposition of Hydrogen Peroxide

Hydrogen peroxide is known to be photodecomposed by absorbing short-wavelength

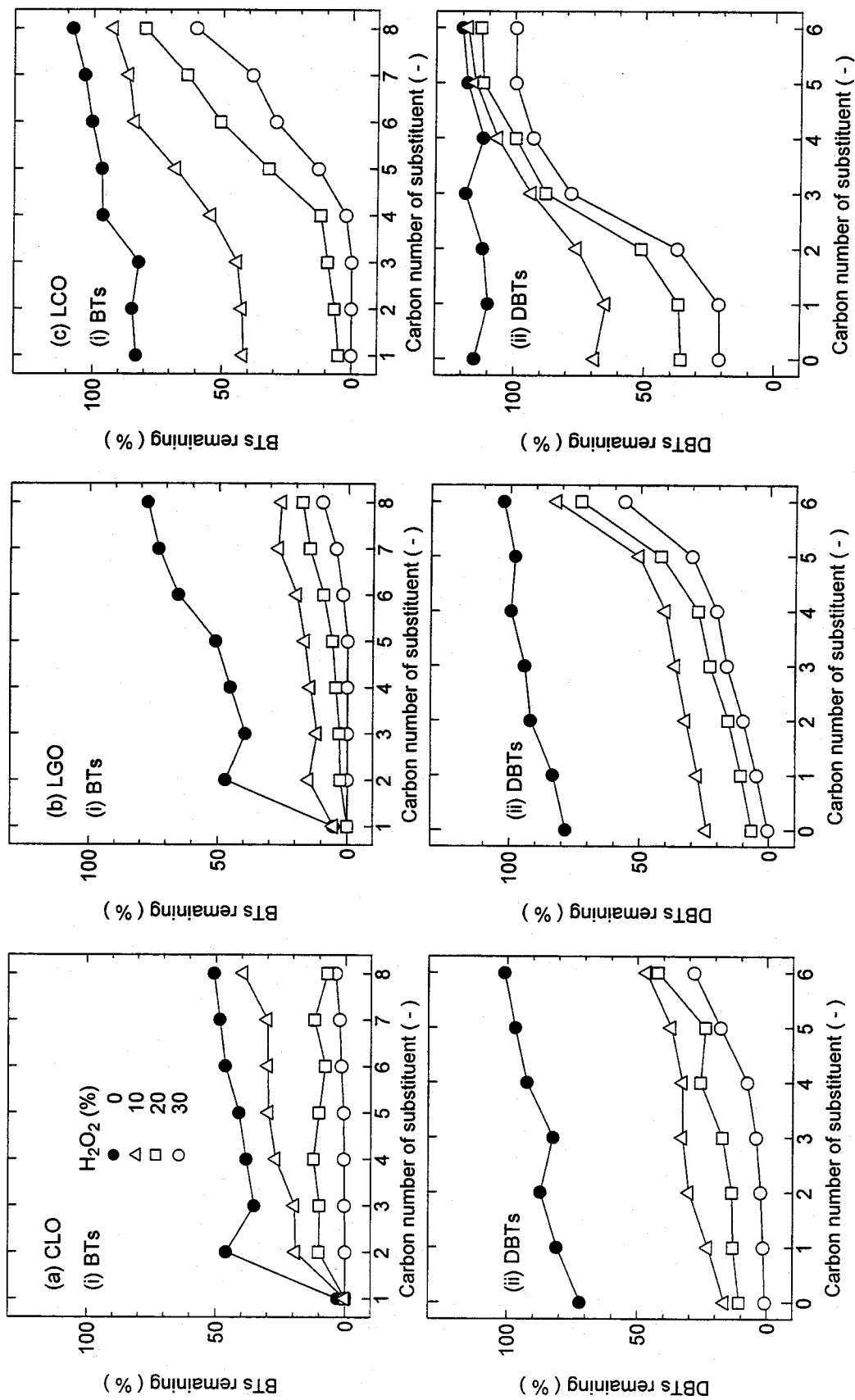

Figure 2-7. Remaining percentage of (i) BTs and (ii) DBTs in light oils following 36 h irradiation, with respect to the H₂O₂ concentration. Initial quantity of each alkyl-substituted compound in light oils set as 100%.

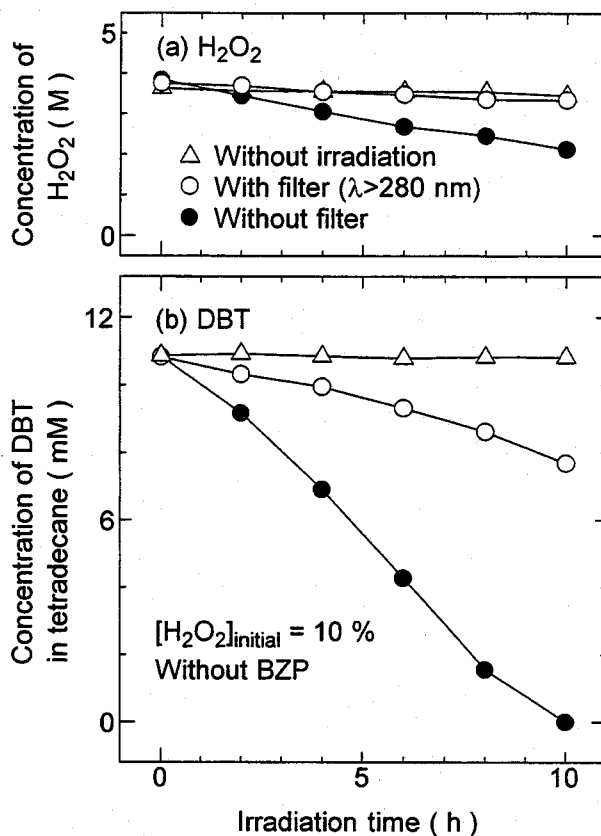

Figure 2-8. Effect of irradiative wavelength on time-course variation in the concentrations of (a) H₂O₂ in the water phase and (b) DBT in the tetradecane phase, in tetradecane/H₂O₂ (10%) aqueous solution two-phase system ($\lambda > 280$ nm).

UV light (Volman and Chen., 1959). The effect of the irradiative wavelength on the decomposition of H₂O₂ was therefore studied, using model light oil (containing DBT). The results are shown in **Figure 2-8**. With irradiation of entire wavelength region of light from high pressure mercury lamp, the H₂O₂ concentration in water phase was seen to be significantly reduced. Use of Pyrex filter ($\lambda > 280$ nm), however, markedly reduced the rate of decomposition of H₂O₂. The quantity of the H₂O₂ decomposed was only 10% as compared to the case of that without filter, and this was comparable with that for zero irradiation where only the thermal decomposition is likely to occur (Christensen et al., 1982). The desulfurization of DBT was also suppressed considerably by the use of the filter, since the quantity of photoexcited DBT was decreased. These results indicate therefore that an alternative method for the indirect photoexcitation of DBT, effected by the irradiation of long-wavelength light ($\lambda > 280$ nm), is required in order to suppress the photodecomposition of H₂O₂.

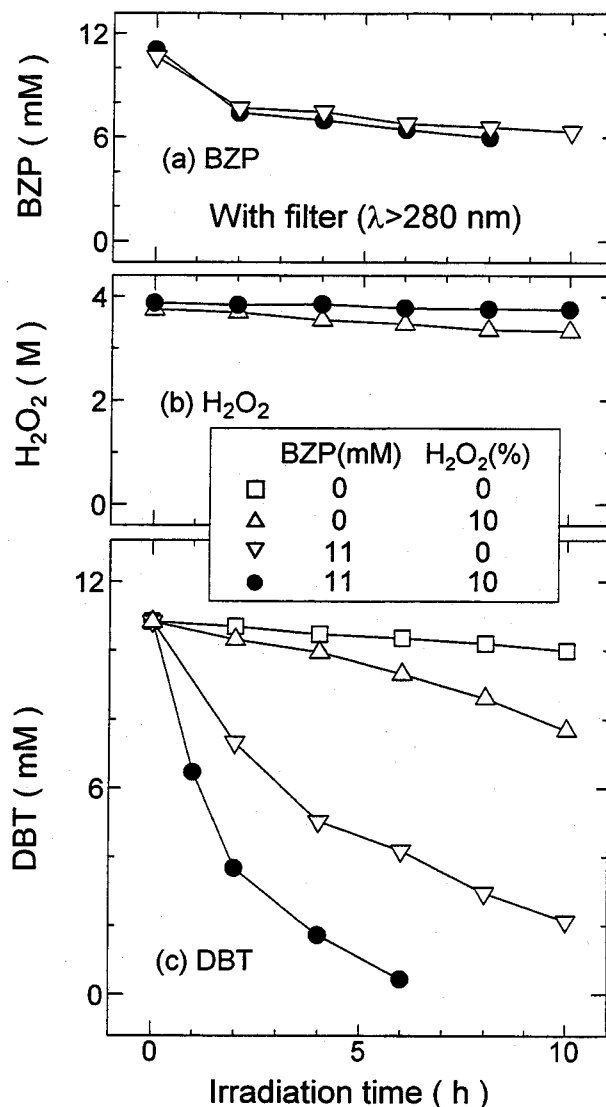

Figure 2-9. Effect of the addition of BZP and H₂O₂ on the time-course variation in the concentrations of (a) BZP, (b) H₂O₂, and (c) DBT in a tetradecane/water system ($\lambda > 280\text{nm}$).

Benzophenone (BZP), a triplet photosensitizer, which is photoexcited at wavelengths of longer than 380 nm, enables the indirect photoexcitation of DBT under the irradiation at wavelength of $\lambda > 280\text{ nm}$, as described in Chapter I. The effect of the addition of BZP into the tetradecane phase together with H₂O₂ was then investigated. **Figure 2-9** shows the time-course variation in the concentration of DBT and BZP in tetradecane and H₂O₂ in water phase during photoirradiation. The rate of desulfurization of DBT was accelerated by the addition of BZP or H₂O₂, when added singly, but was much enhanced by the addition of BZP and H₂O₂ together. The rate of decomposition of H₂O₂ was not affected by the presence of BZP, and likewise the rate of decomposition of BZP was also

not affected by the presence of H₂O₂. With both BZP and H₂O₂, the amount of H₂O₂ consumed for every mole of DBT following 2 h photoirradiation was estimated as 15 mol, whereas 707 mol of H₂O₂ was decomposed in the case where entire wavelength of light was irradiated without BZP.

2.2. Relationship among the Concentrations of DBT, BZP, and Hydrogen Peroxide in the Desulfurization of DBT from Tetradecane

Figure 2-10 shows the effect of the addition of BZP and/or H₂O₂ on the rate of desulfurization of DBT from tetradecane. With the addition of BZP alone, the concentration of DBT decreased markedly with increasing BZP concentration in the range, [BZP] = 0.5–2.7 mM. The desulfurization rate, however, becomes almost saturated at [BZP] > 2.7 mM. With H₂O₂ alone being added, the rate of desulfurization was accelerated with increasing [H₂O₂], but with the rate being rather less than that for the case with BZP alone being added. With the addition of both BZP (11 mM) and H₂O₂, the rate of desulfurization was considerably enhanced, and almost all the DBT was removed following 8 h photoirradiation. In this case, the addition of H₂O₂ more than 10%, however, hardly affected the rate of desulfurization obtained. The relationship between the differing concentrations of BZP, H₂O₂, and DBT on the rate of desulfurization of DBT from tetradecane was studied. Here, the rate was defined as the difference between the concentrations of DBT in tetradecane at the times of 0 and at 6 h, as follows:

$$r_{\text{DBT}} = ([\text{DBT}]_{0\text{h}} - [\text{DBT}]_{6\text{h}}) / 6 \quad (2-5)$$

These results are shown in Figure 2-11. With BZP alone, the desulfurization rate of DBT increased linearly with increasing [BZP] up to approximately 2 mM, and the rate became saturated at [BZP] > 11 mM, as shown in Figure 2-11a. This behavior was unaffected by the air bubbling rate, and thus the solution appears to be saturated with oxygen. The difference in triplet energy (ΔE_T) between DBT and BZP in nonpolar solvents is only 2 kJ/mol. When the ΔE_T value is less than a few kJ/mol, the reverse triplet-energy transfer occurs (Kira and Thomas, 1974; Gessner and Scaiano, 1985). Yamaji et al. (1997) have reported the formation of a triplet equilibrium in the DBT-BZP system in acetonitrile solution. Therefore, the reverse-energy transfer from excited DBT

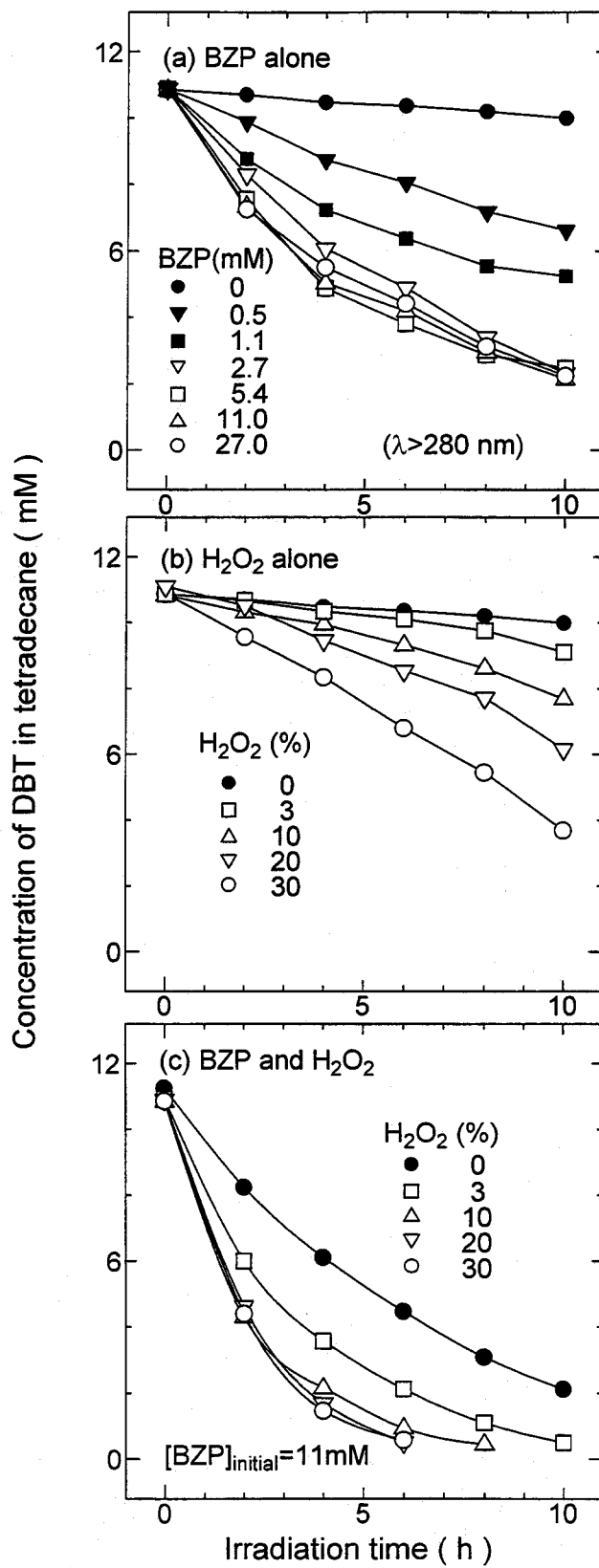

Figure 2-10. Time-course variation in the concentration of DBT in tetradecane with the addition of (a) BZP alone, (b) H₂O₂ alone, and (c) both BZP and H₂O₂.

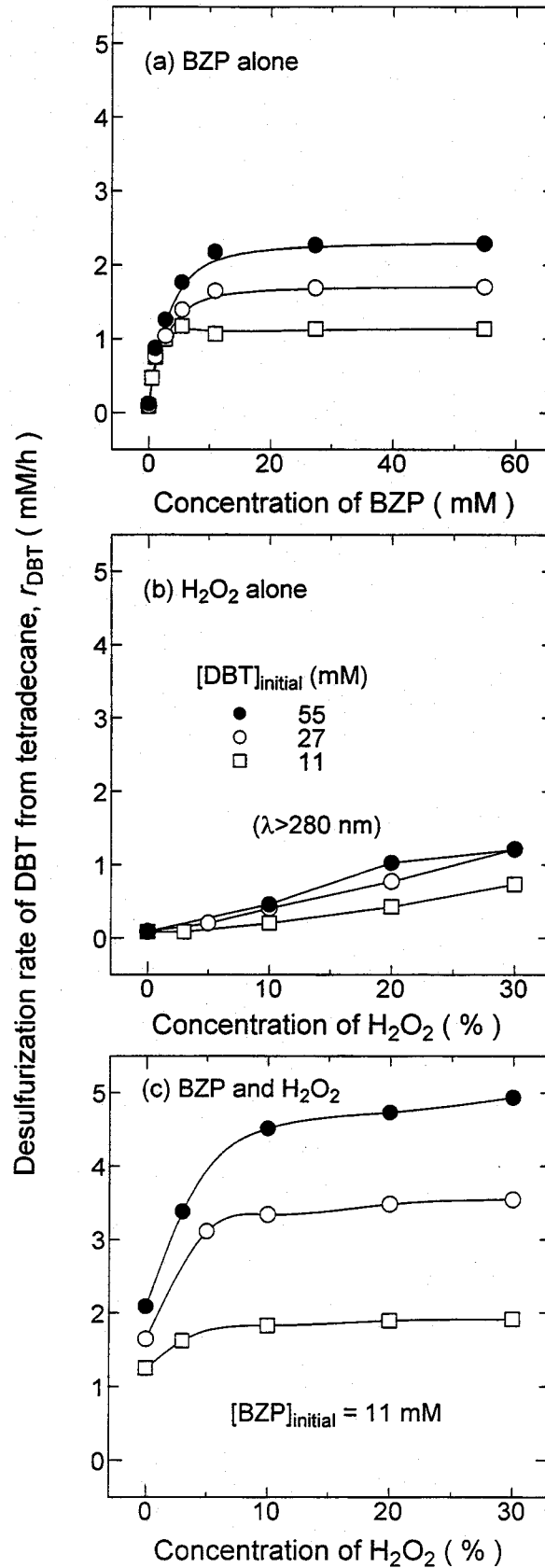
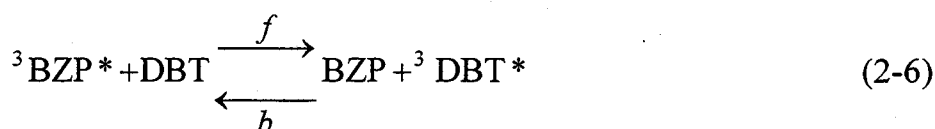

Figure 2-11. Effect of the addition of (a) BZP alone, (b) H₂O₂ alone, and (c) both BZP and H₂O₂ on the desulfurization rate of DBT from tetradecane, r_{DBT} , with respect to the initial concentration of DBT.

to the ground-state BZP can occur, as:



The triplet equilibrium between DBT and BZP is formed at the excited states, and the corresponding equilibrium constant can be represented as:

$$K_{\text{eq}} = \exp\left(\frac{\Delta E_T}{RT}\right) = \frac{[{}^3\text{DBT}^*][\text{BZP}]}{[{}^3\text{BZP}^*][\text{DBT}]} \quad (2-7)$$

where R is the ideal gas constant and T is the temperature (K). For the present experimental conditions, the K_{eq} value was determined as 2.11 at 323 K. The excess addition of BZP, therefore, reduces the formation of ${}^3\text{DBT}^*$, and approximately 11 mM of BZP seems sufficient to increase the desulfurization rate. The desulfurization rate was increased by increasing $[\text{DBT}]_{\text{initial}}$, since the equilibrium, as shown by eq. (2-6), shifts to the right with increasing $[\text{DBT}]_{\text{initial}}$. The increase in the desulfurization rate with $[\text{DBT}]_{\text{initial}}$ was minor at $[\text{BZP}] > 11$ mM, thus indicating that the quantity of O_2 is less than that of ${}^3\text{DBT}^*$ in this high BZP concentration region.

The effect of the addition of H_2O_2 alone is shown in **Figure 2-11b**. Here, the desulfurization rate increased only slightly with increasing $[\text{H}_2\text{O}_2]$. H_2O_2 acts as an oxidizing agent against photoexcited DBT, and therefore, the addition of H_2O_2 alone is ineffective under the present irradiation condition ($\lambda > 280$ nm), for which the direct excitation of DBT hardly occurs. With both BZP and H_2O_2 added together, as shown in **Figure 2-11c**, the rate increased 2-fold or 5-fold compared to that for the cases with only BZP or H_2O_2 alone additions. The rate obtained with both BZP and H_2O_2 present was also enhanced with increasing $[\text{DBT}]_{\text{initial}}$. This is because the number of excited molecules of DBT, which can be oxidized effectively by H_2O_2 molecules, was increased with increasing $[\text{DBT}]_{\text{initial}}$. In the combined system, the desulfurization rate was almost saturated at $[\text{H}_2\text{O}_2] > 10\%$, thus indicating that the quantity of the H_2O_2 molecules was in sufficient excess, as compared to that of the excited DBT molecules. Thus, the proposed process is likely to be effective for the desulfurization of light oils containing large quantities of DBTs.

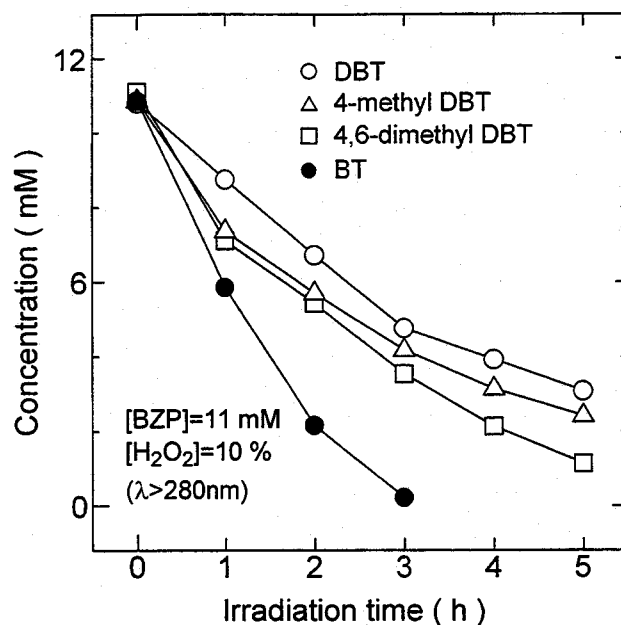

Figure 2-12. Comparison of the desulfurization rate of DBT, its alkyl-substituted derivatives, and BT from tetradecane.

2.3. Photoreactivity of Methyl-Substituted DBTs and Benzothiophene, and the Effect of Naphthalene on the Desulfurization of DBT

The photoreactivity of methyl-substituted DBTs and benzothiophene (BT) was also studied. The reactivity of 4-methyl and 4,6-dimethyl DBT was found to be higher than that of DBT, and the order is 4,6-dimethyl DBT > 4-methyl DBT > DBT, as shown in **Figure 2-12**. This is the same order as that obtained for the case where the entire wavelength region from the mercury lamp was used in the presence of H_2O_2 alone, as shown in **Figure 2-4**. The methyl substituents cause the expansion of the electronic cloud on aromatic moiety. The energy transfer occurs via the collision and the association between ${}^3BZP^*$ and ground-state DBTs (Dexter, 1953), and thus methyl-substituted DBTs strongly associate with ${}^3BZP^*$, resulting in the higher desulfurization yield. The photoreactivity of BT was found to be higher than that of DBTs. The electron density on unsaturated 2- and 3-positions of BT is high, and therefore the energy transfer from ${}^3BZP^*$ to BT occurs effectively; as a result, desulfurization of BT proceeds more effectively.

Figure 2-13 shows the effect of BZP and H_2O_2 on the desulfurization of DBT in the presence of naphthalene. When using the Pyrex filter ($\lambda > 280$ nm), both BZP or H_2O_2 , when added separately, were found to be ineffective for the desulfurization of DBT.

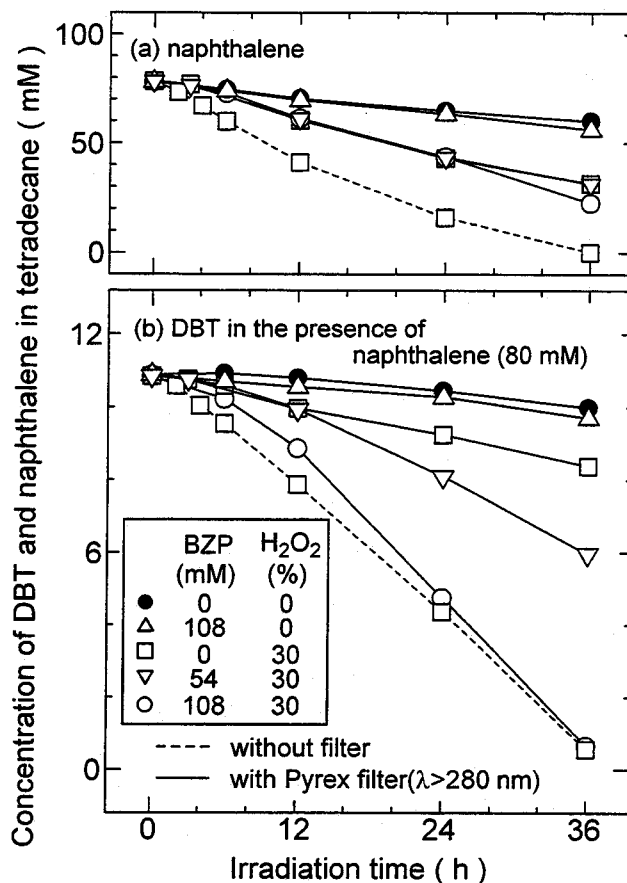
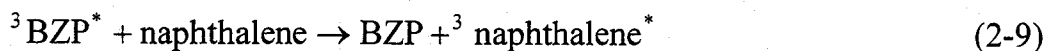

Figure 2-13. Effect of the addition of BZP and H₂O₂ on the time-course variation in the concentrations of (a) naphthalene and (b) DBT in tetradecane.

This is because of the energy transfer from photoexcited DBT to the ground-state naphthalene. With both BZP and H₂O₂ together, the desulfurization rate was increased to a level which was comparable to that in the case of H₂O₂ alone without a Pyrex filter. As was shown in **Figure 2-11a**, the desulfurization is not enhanced by the addition of BZP in excess of 2.7 mM in the absence of naphthalene. In the presence of naphthalene, the rate was, in contrast, accelerated by increasing [BZP], as shown in **Figure 2-13**. Since naphthalene is also excited by the energy transfer from BZP (Terenin and Ermolaev, 1956), the competitive energy transfer thus occurs, as follows:



Thus, the addition of a large quantity of BZP is effective for the formation of ³DBT* in the presence of naphthalene. In addition, under the irradiation conditions of λ > 280 nm, the degradation of naphthalene is also suppressed, owing to a reduction in the direct excitation

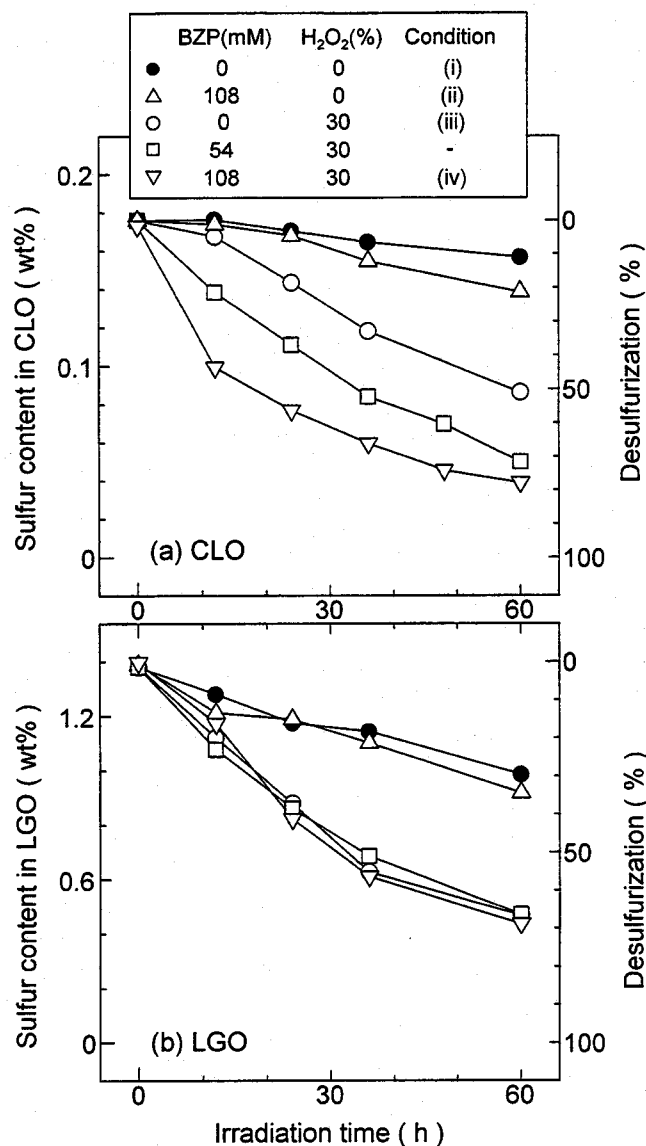

Figure 2-14. Effect of the addition of BZP and H₂O₂ on desulfurization of (a) CLO and (b) LGO ($\lambda > 280$ nm).

of naphthalene.

2.4. Desulfurization of Light Oils Using Both Benzophenone and Hydrogen Peroxide

Figure 2-14 shows the effect of the addition of BZP and/or H₂O₂ when applied to the desulfurization of light oils. As shown in **Figure 2-14a**, for commercial light oil (CLO), with neither BZP nor H₂O₂ present (condition (i)), only 10% of the sulfur was removed following 60 h photoirradiation. Also, for either BZP or H₂O₂ alone ((ii) or (iii)), only 20% or 50% respectively of the sulfur was removed. With the addition of both 108 mM BZP and 30% H₂O₂ (iv), the desulfurization was accelerated very effectively, and the sulfur content was reduced following 48 h photoirradiation to a value of less than 0.05

wt%. On the other hand, desulfurization of straight-run light gas oil (LGO) was found to be well-affected by the addition of H_2O_2 alone (iii), and any effect of the BZP did not appear to be very obvious (iv), as shown in **Figure 2-14b**. From the data shown in **Table 1-1**, LGO contains a 2-fold greater quantity of bicyclic aromatic compounds than does CLO. Thus, the energy transfer from BZP to DBTs is hardly effective at $[BZP] < 108$ mM. The proposed process is therefore effective for the desulfurization of the light oils containing low level bicyclic aromatic components. The desulfurization of aromatic-rich light oils such as LGO and light cycle oil (LCO) is difficult according to the proposed process. It was, however, found to be achieved effectively by employing photoirradiation of the entire wavelength region from the mercury lamp in an oil/hydrogen peroxide aqueous solution two-phase system. The recoveries of the light oil, following desulfurization, were found to be higher as compared with those obtained by the irradiation of entire wavelength region of light using only H_2O_2 ; (i) 95%, (ii) 93%, (iii) 87%, and (iv) 86%, at the respective desulfurization conditions, as shown in **Figure 2-14**.

To establish the reactivities of the various sulfur-containing compounds, each compound remaining in the light oil, following desulfurization, was determined. The light oils, following desulfurization, were analyzed by GC-AED. **Table 2-2** lists the quantities of the individual sulfur-containing compounds remaining in desulfurized CLO, following 60 h photoirradiation, for the various conditions according to **Figure 2-14**. The results show that more than 60% of the BTs were removed in the absence of both BZP and H_2O_2 , and that the BTs were further reduced to a concentration level of less than 5% by the addition of both BZP and H_2O_2 . Under this latter condition (iv: 108 mM BZP and 30% H_2O_2), more refractory DBTs were also reduced effectively to less than 30%.

Figure 2-15 shows the remaining percentage values for BTs and DBTs, having different carbon number substituents, for desulfurized CLO. The residual percentage of BTs was decreased effectively by the addition of BZP and H_2O_2 , although the residual percentage increased with increasing the carbon number of the substituent. With H_2O_2 alone, the C0–C4 DBTs were effectively desulfurized, but the desulfurization was not so easy for the C5 and C6 DBTs. By employing both BZP and H_2O_2 together, however, about 60% and 50% of C5 and C6 DBTs respectively were removed. Thus, the present method is definitely effective for deep desulfurization. The highly substituted DBTs

Table 2-2. Quantities of Benzothiophenes (BTs) and Dibenzothiophenes (DBTs) Having Different Carbon Number Substituent in the Feed Commercial Light Oil (CLO) and the Oil After 60 h Photoirradiation of Long Wavelength Light ($\lambda > 280$ nm) [Conditions (i)-(iv) are Identical to Those in Figure 2-14]

(condition)	feed CLO species (wt%)	desulfurized CLO			
		(i) 0 mM, 0% (wt%)	(ii) 108 mM, 0% (wt%)	(iii) 0 mM, 30% (wt%)	(iv) 108 mM, 30% (wt%)
< C1-BT*	0.00902	0	0	0	0
C2-BT	0.00525	0.00201	0.00142	0.00019	0.00005
C3-BT	0.01102	0.00399	0.00252	0.00066	0.00022
C4-BT	0.01007	0.00411	0.00322	0.00115	0.00047
C5-BT	0.00632	0.00302	0.00232	0.00092	0.00038
C6-BT	0.01008	0.00523	0.00421	0.00234	0.00108
C7-BT	0.00138	0.00091	0.00067	0.00044	0.00016
C8-BT	0.00334	0.00221	0.00182	0.00121	0.00045
BTs (total)	0.05648	0.02148	0.01618	0.00691	0.00281
DBT	0.00332	0.00279	0.00232	0.00041	0.00022
C1-DBT	0.01134	0.01031	0.00847	0.00203	0.00080
C2-DBT	0.02151	0.02052	0.01587	0.00503	0.00149
C3-DBT	0.02241	0.02178	0.01711	0.00734	0.00222
C4-DBT	0.01320	0.01212	0.01179	0.00708	0.00252
C5-DBT	0.00393	0.00391	0.00379	0.00403	0.00141
C6-DBT	0.04381	0.04561	0.04467	0.04028	0.02202
DBTs (total)	0.11952	0.11704	0.10402	0.06620	0.03068
Total sulfur	0.17600	0.13852	0.12020	0.07311	0.03349

*< C1-BT contains also nonsubstituted BT and alkyl and arylsulfides.

were also found to be most difficult compounds to be desulfurized, as was also the case where entire wavelength region of light oil was irradiated in the presence of H₂O₂ alone.

The photoirradiation to fuel oil is known to cause the generation of hydroperoxides (Larson et al., 1979), which have a detrimental effect on the properties of oils. The concentrations of hydroperoxide and oxygen in treated light oil were determined as 0.31 mol/L and 0.88 wt% respectively, following 48 h photoirradiation with 108 mM BZP and 30% H₂O₂. When irradiated in the presence of 30% H₂O₂ alone without filter, the higher

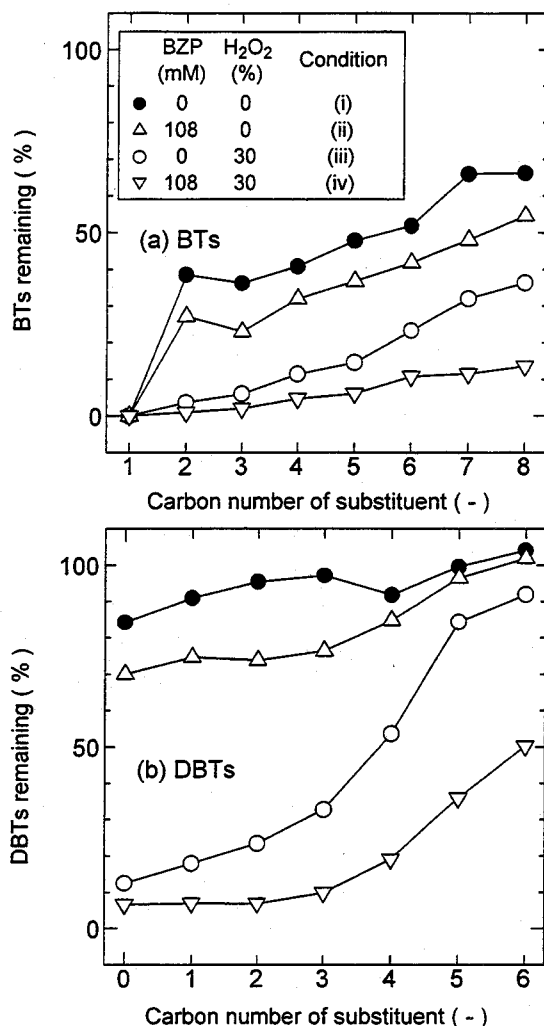

Figure 2-15. Effect of the addition of BZP and H_2O_2 on the changes of remaining percentage for (a) BTs and (b) DBTs in commercial light oil (concentrations at 0 h photoirradiation were set as 100%) following 60 h photoirradiation. Conditions (i)-(iv) are identical to those in **Figure 2-8**.

values of 0.52 mol/L and 1.13 wt% were obtained. Therefore, although the presence of H_2O_2 enhances the decomposition of hydrocarbons, it can be suppressed by employing the present process. The hydroperoxide formed was easily removed and reduced to less than 0.001 mol/L by adding a small amount of molecular sieves 3A due to their large polarity.

2.5. Separation of Desulfurized Compounds from Hydrogen Peroxide Solution

Separation of the photooxidized sulfur-containing compounds from the aqueous H_2O_2 solution was also investigated. Ion chromatography analysis showed, in the present photochemical desulfurization process, that the desulfurized components were not converted to the sulfate anion, and thus were possibly converted to aromatic sulfate anion

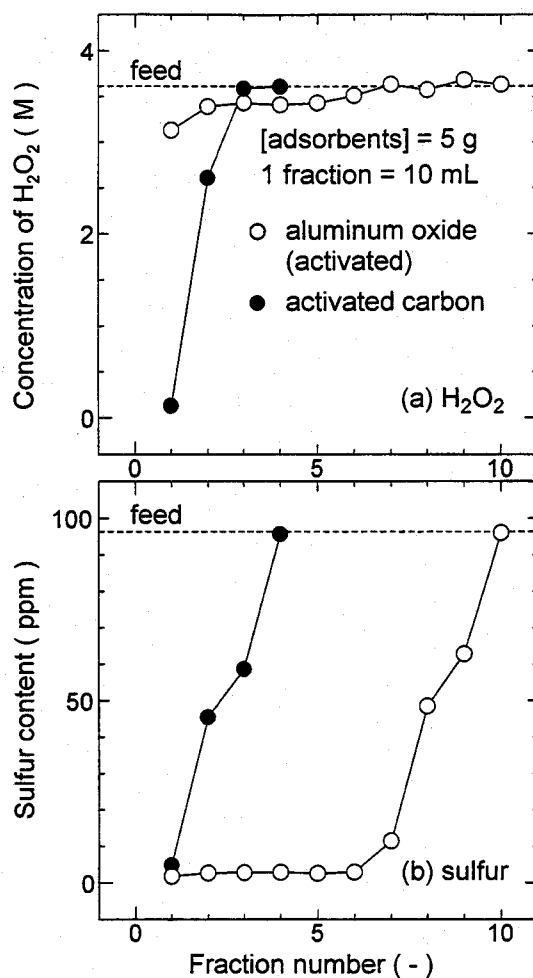

Figure 2-16. The variation of the concentrations of (a) H₂O₂ and (b) sulfur contained in the eluent from the adsorption column packed with activated carbon or aluminum oxide, when the water phase after desulfurization was being fed.

form. Aluminum oxide and activated carbon are used in most cases as adsorbents for highly polarized compounds in nonpolar solvents (Abu Bakr and Hamid, 1997) and also for organic components in aqueous solutions (Lin and Chen, 1997). The DBT/tetradecane and 10% H₂O₂ solutions were mixed and photoirradiated for 20 h and the aqueous phase was recovered. The aqueous phase was introduced to the top of the column, containing 5 g of adsorbents, and the eluted fractions (10 mL) were analyzed. **Figure 2-16** shows the variation in the concentrations of H₂O₂ and sulfur found in the eluted fractions. With an aluminum oxide adsorbent, the sulfur was essentially adsorbed up to fraction no. 6, and no adsorption of H₂O₂ was detected, whereas the activated carbon column appeared to be ineffective. The sulfur adsorbed by the aluminum oxide was estimated to be about 5g/kg-aluminum oxide. Thus, employing adsorption, on the

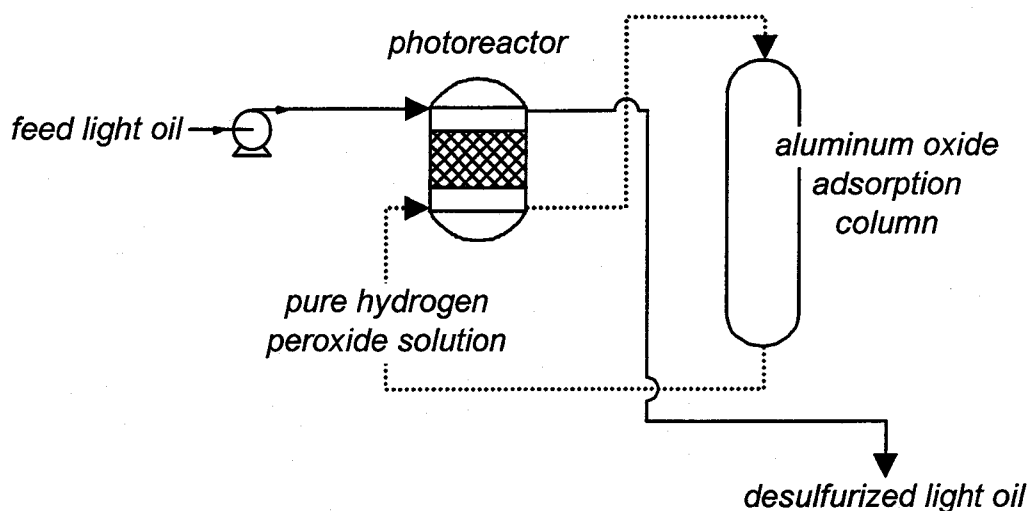

Figure 2-17. Schematic flow chart for the deep desulfurization process for light oils.

basis of aluminum oxide, it is possible to recover pure H_2O_2 solution, which can then be reused for desulfurization, as schematically shown in **Figure 2-17**.

Summary

The effect of the addition of hydrogen peroxide on the desulfurization of light oils has been investigated, using an oil/water two-phase system, and the following results obtained.

(1) The effect of the addition of H_2O_2 was studied by the irradiation of entire wavelength region of light. The addition of H_2O_2 enhanced the desulfurization of DBT from tetradecane, even in the presence of naphthalene, since the H_2O_2 acts to oxidize the photoexcited DBT and suppress the triplet energy transfer from the photoexcited DBT to naphthalene significantly. This was also effective for the desulfurization of BTs and alkyl-substituted DBTs.

(2) With the addition of H_2O_2 , the desulfurization of light oils was markedly enhanced. At a 30% H_2O_2 concentration and 36 h photoirradiation, sulfur content of commercial light oil (CLO) was lowered from 0.2 to 0.02 wt%, and from 1.4 to 0.4 wt% for straight-run light gas oil (LGO), and 0.13 to 0.05 wt% for light cycle oil (LCO). These obtained sulfur contents are below the value now strictly regulated in Japan. GC-AED analysis showed that the BTs and DBTs in CLO and LGO, and BTs and C1–C3 DBTs in LCO

were desulfurized effectively by the addition of H_2O_2 . Highly substituted DBTs, especially C4–6 DBTs in LCO, were most difficult compounds to be desulfurized according to the proposed method.

(3) To suppress the photodecomposition of H_2O_2 and sulfur-free aromatic hydrocarbons, the effect of the simultaneous addition of BZP to the tetradecane phase and H_2O_2 into the water phase was studied, under the irradiation of relatively long-wavelength region of light ($\lambda > 280 \text{ nm}$). The removal of DBTs and BTs was thereby significantly accelerated as compared to the cases for the addition of either BZP or H_2O_2 . Photodecomposition of H_2O_2 and aromatic hydrocarbons was suppressed by employing the photoirradiation conditions of wavelength $\lambda > 280 \text{ nm}$.

(4) The desulfurization of commercial light oil (CLO) was enhanced according to the present method, in that the sulfur content was reduced effectively from 0.2 to less than 0.05 wt%. The addition of BZP was found to be ineffective for the desulfurization of aromatic rich light oil. BTs were easily desulfurized by the addition of either BZP or H_2O_2 alone, whereas DBTs, especially C5 and C6 derivatives, were hardly desulfurized. Desulfurization of these refractory compounds proceeded effectively only in the presence of both BZP and H_2O_2 . The photooxidized sulfur compounds in the water phase could be separated from the H_2O_2 aqueous solution without decomposition of H_2O_2 by an adsorption process using aluminum oxide, thus enable the recovered H_2O_2 aqueous solution to be recycled.

Chapter III

Desulfurization of Light Oils by UV Irradiation in an Organic Two-Phase Extraction System

Introduction

In previous Chapters I and II, the desulfurization process for light oils, using "oil/water two-phase system," has been investigated. The basic idea for the process was the photodecomposition of the sulfur-containing compounds in light oil phase, followed by the transfer of the resulting decomposed compounds into the water phase. Since the photodecomposition of DBTs in these processes occurs in the nonpolar light oil phase, the deactivation of photoexcited DBTs is inevitably accompanied by the triplet energy transfer from the photoexcited DBTs to the ground-state bicyclic aromatic hydrocarbons such as naphthalene having lower triplet energy. Although the desulfurization was enhanced by the addition of hydrogen peroxide to the water phase, long photoirradiation time was required to achieve the deep desulfurization (0.05 wt%) of light oils. New idea and concept are therefore required to overcome the principal problem.

In this chapter, a new extraction and photoreaction system has been studied, based on the polarity difference between the sulfur-containing compounds and the aliphatic components of light oils. The photooxidation of sulfur-containing compounds is known to proceed more effectively in polar solvents, since the key intermediates and products are more polar than the starting compounds. The new idea is to transfer the sulfur-containing compounds to other phase at first, and then to photooxidize and photodecompose them there. The polar solvent, immiscible with the nonpolar feed light oils, can be employed as an extraction phase, to make an "organic two-phase extraction system." The sulfur-containing compounds, BTs and DBTs, have a relatively high polarity, and tend to transfer to the polar solvents, together with several aromatic compounds. Applicability of the present process to the deep desulfurization of actual light oils is studied, and the overall desulfurization process for light oils, in which the solvents can be recovered and reused, is developed. These are described in the first half of this chapter. The identification of the photoproducts and photodecomposition

pathways for BT and DBT, and their methyl-substituted derivatives during the present process are described in detail in the latter half of this chapter.

Experimental Section

1. Materials

In addition to the materials described in Chapters I and II, acetonitrile, dimethyl sulfoxide (DMSO), tetramethylene sulfone (sulfolane), and 2-propanol were used. 3-Methyl and 2,3-dimethyl BT were synthesized according to the procedures of Werner (1949) and Banfield et al. (1956) and were used following purification by flash chromatography using silica gel packing and *n*-hexane/benzene (80/20) as the eluent. DBT sulfoxide, DBT sulfone, and their 4-methyl and 4,6-dimethylated derivatives were synthesized from their corresponding DBTs using the H₂O₂-AcOH oxidation procedure (Gilman and Esmay, 1952), and were utilized following a recrystallization from benzene. Dibenz[*c,e*][1,2]oxathiin-6-oxide and -6,6-dioxide were synthesized from 2-hydroxybiphenyl (Wako), according to the procedures of Hanson and Kemp (1981). Benzothiophene-2,3-dione and -2,3-dicarboxylic acid anhydride were synthesized according to the procedure of Papa et al. (1949) and Hannoun et al. (1982). Diazomethane was prepared from diazald (Aldrich Chemical Co. Inc.) by hydrolysis using 30% KOH aqueous solution (Kirkland, 1960), and the products were collected in cooled diethyl ether.

2. Apparatus and Procedure

The light oils were mixed vigorously, using a magnetic stirrer, with polar solvent solution at a volume ratio varying from 50/350 to 200/200 mL/mL with a total solution volume of 400 mL. The solutions were photoirradiated by the immersion of a high-pressure mercury lamp (300 W, Eikohsha Co., Ltd., Osaka), combined with air bubbling (500 mL/min) at atmospheric pressure (**Figure 1-1**). The entire wavelength region of light was utilized. The photoreactor was equipped with a reflux condenser to minimize the loss of solvent by evaporation. The starting sulfur-containing compounds, dissolved in homogeneous polar solvent (400 mL), were also employed for photoreaction studies, combined with stirring and air bubbling. The resulting acetonitrile solution was used

without additional treatment for LC analysis. For analysis of acidic products, the GC sample was prepared by evaporating the acetonitrile, followed by redissolution of the resulting precipitate into chloroform. Methylation of acidic components was conducted according to the procedure of Kirkland (1960). Ether solution containing diazomethane was added to a portion of the resulting acetonitrile solution with agitation, and an additional 15–20% excess volume of diazomethane solution was added. The resulting mixture was allowed to stand for about 10 min. The solvent was then carefully evaporated and the residue was transferred to chloroform.

3. Analysis

The full procedure was described in Chapters I and II, and only a brief description is presented here. Concentrations of sulfur-containing compounds in polar solvents were analyzed by reverse-phase HPLC (Shimadzu LC-6A, equipped with a spectrophotometric detector SPD-6A) at 241 nm. Separations were performed on a $150 \times 4.6 \text{ mm}^2$ i.d. Shim-pack column (Shimadzu HRC-ODS), using acetonitrile/water (50/50 v/v) isocratic elution with a flow rate of 1.0 mL/min. The acidic compounds were analyzed quantitatively by ion-pair chromatography using a tetrabutylammonium dihydrogenphosphate as a counterion.

Results and Discussion

1. Desulfurization Process of Light Oils Using an Organic Two-Phase System

1.1. Liquid–Liquid Extraction of Sulfur-Containing Compounds

The extractability of the sulfur-containing compounds and aromatic hydrocarbons from light oil was studied by contacting commercial light oil (CLO) with several polar solvents, such as acetonitrile, DMSO, and sulfolane, under room temperature conditions. The latter two solvents are commercial solvents used for aromatics extraction in the petroleum industry (Bailes, 1983). Extraction equilibrium between CLO and a polar solvent was achieved in 5 min or less, and the phase separation was achieved in about 10 s. The light oil was washed once with an equal volume of water to remove the dissolved polar solvents, prior to analysis. **Table 3-1** shows a comparison of the sulfur and aromatics content of the CLO, before and after contact with polar solvents, at

Table 3-1. Aromatic and Sulfur Content of Commercial Light Oil (CLO) before and after Contact with Polar Solvents (Polar Solvent/CLO Volume Ratio = 3)

	feed	after contact with		
		DMSO	sulfolane	acetonitrile
saturated hydrocarbon (vol%)	76.2	78.7	79.6	82.0
monocyclic aromatics (vol%)	19.5	18.2	17.7	15.5
bicyclic aromatics (vol%)	4.3	3.1	2.7	2.5
total sulfur content (wt%)	0.1896	0.1644	0.1511	0.1322

acetonitrile/CLO volume ratio of 3. In these experiments, acetonitrile is shown to be the most effective solvent for the extraction of the sulfur-containing compounds. The quantity of sulfur extracted to the acetonitrile phase was seen to increase with an increase in the acetonitrile volume added, as expected. Similar results were obtained also for straight-run light gas oil (LGO). Thus, acetonitrile is considered to be the most suitable solvent for light distillates.

Table 3-2 shows the effect of liquid-liquid extraction, using acetonitrile as solvent (acetonitrile/CLO and LGO volume ratio = 3), on the composition of the sulfur-containing compounds in CLO and LGO, as obtained by GC-AED analysis. Using single contact with acetonitrile, 47% of the BTs and 36% of the DBTs in CLO and 39% of the BTs and 24% of DBTs in LGO were removed. The BTs were transferred more to the acetonitrile phase than the DBTs, due to their higher polarity. **Figure 3-1** shows the effect of the carbon number of alkyl substituents on the distribution of BTs and DBTs into the acetonitrile phase. The remaining portion has a tendency to increase with an increase in the carbon number of the alkyl substituents. This indicates that distribution into an acetonitrile phase is reduced with increasing carbon number. This is probably because the polarity of the BTs and DBTs decreases with increasing substitution by the hydrophobic alkyl substituents, as reported by Natusch and Tomkins (1978).

1.2. Photoreaction of Sulfur-Containing Compounds in Polar Solvents

Figure 3-2 shows the time-course variation in the concentrations of DBT during photoirradiation, when dissolved in various solvents. In protic solvents, such as 2-propanol and methanol, no photoreaction of DBT was observed. In acetonitrile, however, DBT was easily photodecomposed and was quantitatively decomposed by 5 h

Table 3-2. Quantities of BTs and DBTs, Having Different Carbon Number Substituents, in (i) feed CLO, LGO, and LCO, and the Oils (ii) Following Simple Extraction (Acetonitrile/Light Oils Volume Ratio = 3 for CLO and LGO, and 15 for LCO) and (iii) following 2h Photoirradiation for CLO and LGO and 10h Photoirradiation for LGO

species	CLO			LGO			LCO		
	(i) (wt%)	(ii) (wt%)	(iii) (wt%)	(i) (wt%)	(ii) (wt%)	(iii) (wt%)	(i) (wt%)	(ii) (wt%)	(iii) (wt%)
<C1-BT*	0.0019	0.0009	0.0002	0.0157	0.0079	0.0024	0.0143	0.0041	0.0002
C2-BT	0.0072	0.0028	0.0006	0.0315	0.0143	0.0055	0.0147	0.0052	0.0003
C3-BT	0.0126	0.0056	0.0016	0.1173	0.0612	0.0215	0.0135	0.0055	0.0002
C4-BT	0.0101	0.0060	0.0025	0.1336	0.0787	0.0279	0.0079	0.0040	0.0001
C5-BT	0.0057	0.0032	0.0011	0.0850	0.0534	0.0195	0.0036	0.0012	0
C6-BT	0.0081	0.0052	0.0019	0.1362	0.0953	0.0356	0.0042	0.0019	0.0001
C7-BT	0.0008	0.0005	0.0002	0.0110	0.0093	0.0033	0.0020	0.0015	0
C8-BT	0.0024	0.0017	0.0007	0.0295	0.0237	0.0088	0.0012	0.0009	0
BTs (total)	0.0488	0.0259	0.0088	0.5598	0.3438	0.1245	0.0614	0.0243	0.0009
DBT	0.0034	0.0015	0.0010	0.0373	0.0214	0.0098	0.0084	0.0030	0.0002
C1-DBT	0.0113	0.0053	0.0027	0.0994	0.0604	0.0306	0.0243	0.0101	0.0004
C2-DBT	0.0230	0.0121	0.0066	0.1547	0.1031	0.0549	0.0223	0.0102	0.0002
C3-DBT	0.0239	0.0143	0.0083	0.1514	0.1123	0.0597	0.0064	0.0029	0.0002
C4-DBT	0.0151	0.0098	0.0059	0.0981	0.0763	0.0423	0.0017	0.0007	0.0002
C5-DBT	0.0041	0.0028	0.0017	0.0270	0.0215	0.0124	0.0004	0.0002	0.0001
C6-DBT	0.0504	0.0383	0.0240	0.2723	0.2412	0.1658	0.0073	0.0022	0.0012
DBTs (total)	0.1312	0.0841	0.0502	0.8402	0.6362	0.3755	0.0708	0.0293	0.0025
total sulfur content	0.1800	0.1100	0.0590	1.4000	0.9800	0.5000	0.1322	0.0536	0.0034

*<C1-BT contains alkyl, aryl sulfides, and nonsubstituted BT.

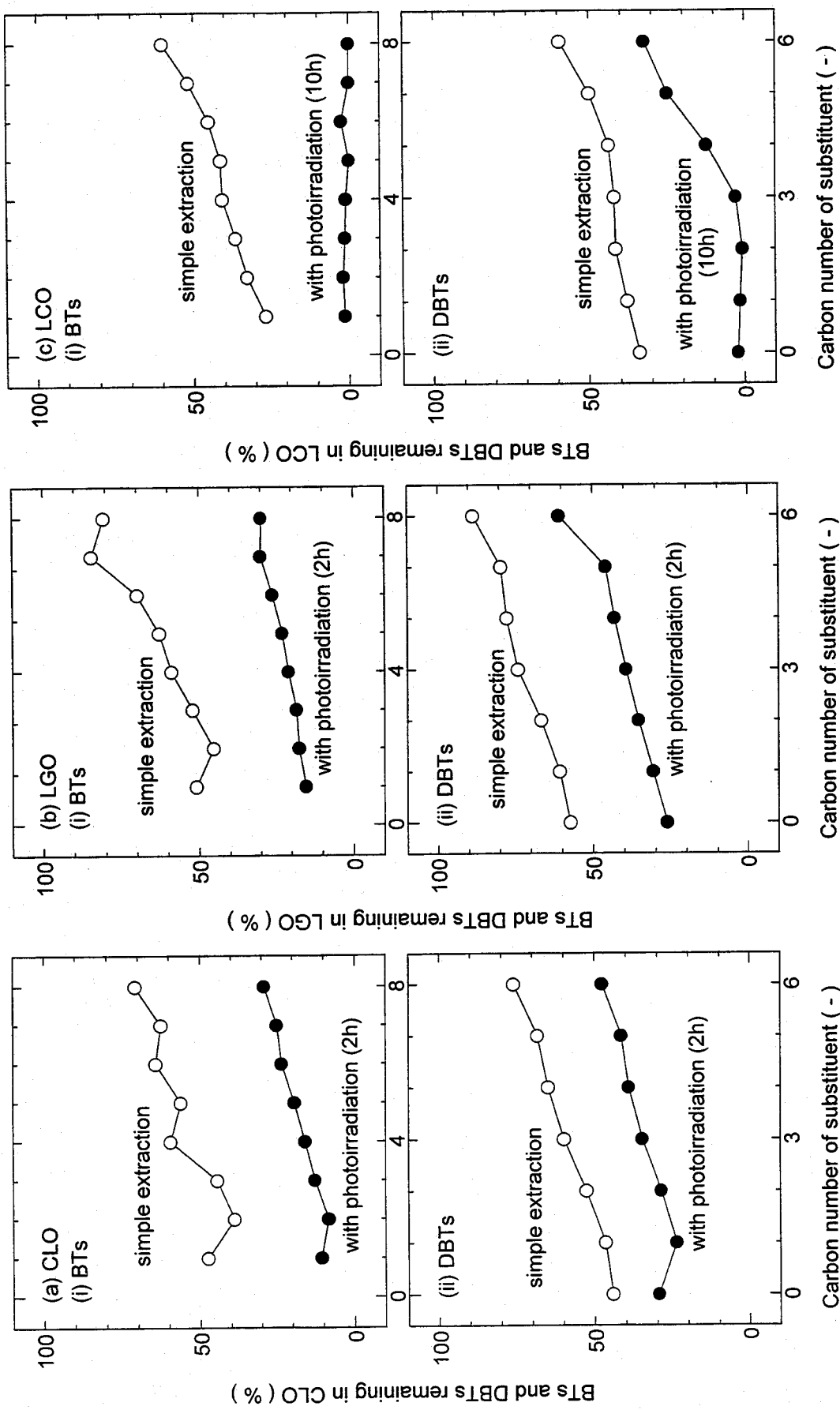

Figure 3-1. Remaining percentage of (i) BTs and (ii) DBTs in (a) CLO, (b) LGO, and (c) LCO following simple extraction (acetone/nitrile/light oil volume ratio = 3 for CLO and LGO, and 15 for LCO) and 2h photoirradiation for CLO and LGO and 10 h for LCO, with respect to the carbon number of the alkyl substituent. The initial amount of each alkyl-substituted compound in the light oil is set as 100 %.

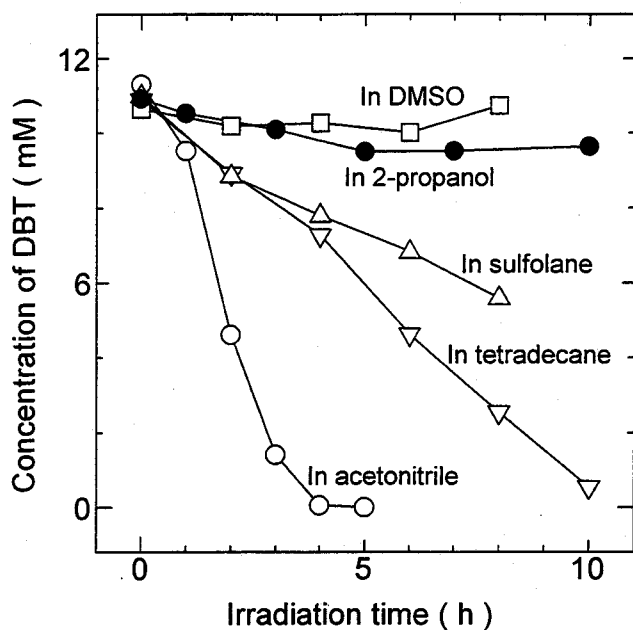

Figure 3-2. Time-course variation in the concentrations of DBT dissolved in various solvents, during photoirradiation.

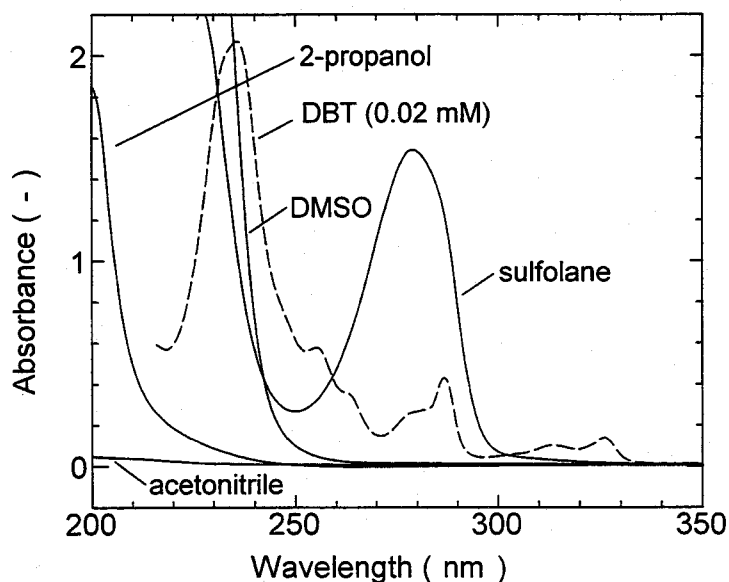

Figure 3-3. Comparison of absorption spectra for DBT and various solvents (reference: air).

photoirradiation. The photodecomposition rate for DBT in acetonitrile was five-fold higher than that in tetradecane, such that DBT appears to react effectively in aprotic solvents. This is probably because the highly polarized intermediates, produced during photodecomposition of DBT, are stabilized in polar solvent. The photoreactivity of DBT both in sulfolane and DMSO was, however, less than that in tetradecane. These sulfur-containing solvents have a broad absorption band starting from 250 nm, as shown in

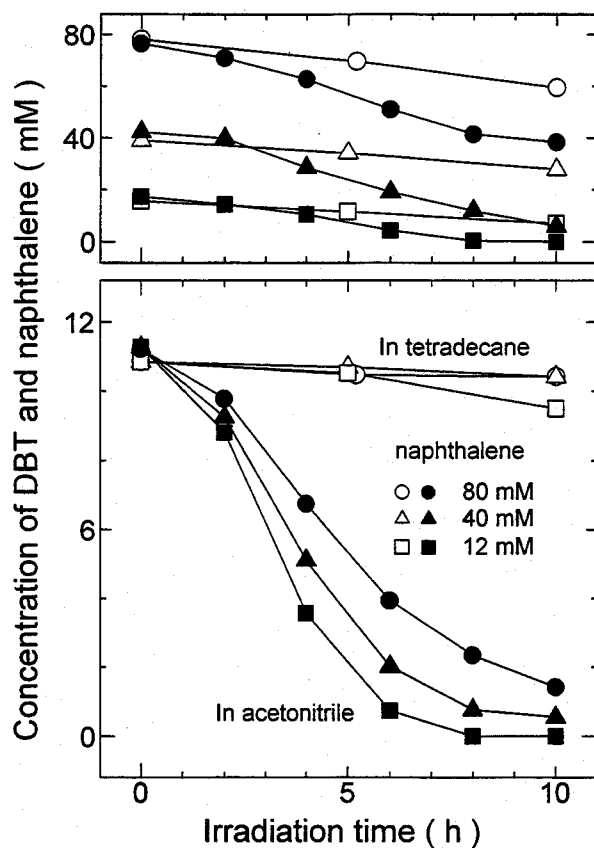

Figure 3-4. Time-course variation in the concentrations of DBT in tetradecane (open symbols) and acetonitrile (closed symbols) with various initial naphthalene concentrations.

Figure 3-3, and thus DBT in these solvents cannot absorb the short-wavelength UV light sufficiently for excitation. Acetonitrile hardly absorbs light in the range 200–300 nm, thus allowing the photoreaction of DBT. Acetonitrile is, thus, regarded to be the most suitable solvent for the photoreaction of DBT.

Figure 3-4 shows the time-course variation in the concentrations of DBT in tetradecane and acetonitrile in the presence of naphthalene. DBT in tetradecane is hardly photodecomposed, because of the triplet energy transfer from the photoexcited DBT to the ground-state naphthalene, as described in Chapter I. In acetonitrile, although the decomposition rate is slightly decreased by an increase in the concentration of naphthalene, DBT was nevertheless still photodecomposed satisfactorily even in the presence of naphthalene. This is probably because the intermediates formed during the photodecomposition of DBT are stabilized in the polar acetonitrile solution. The energy transfer from the excited DBT to the ground-state naphthalene is thereby actually suppressed significantly in acetonitrile.

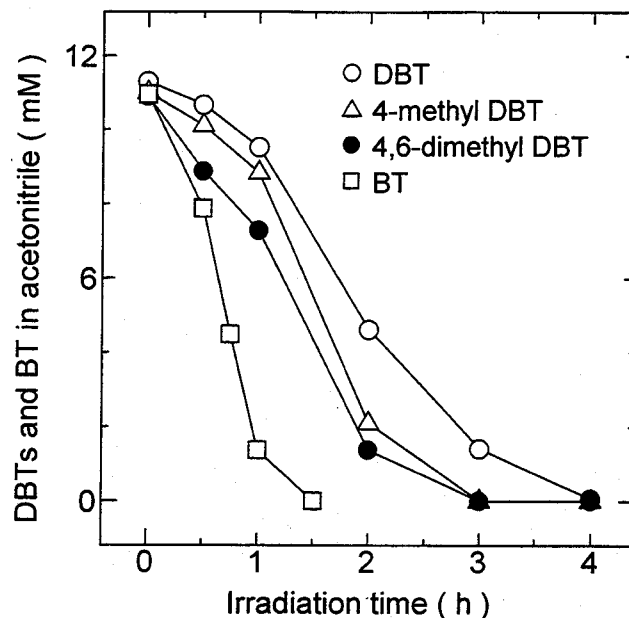

Figure 3-5. Comparison of the photodecomposition rate of DBT, its alkyl-substituted derivatives, and BT in acetonitrile.

By GC-AED and GC-MS analyses, the DBT during photoirradiation in acetonitrile were found to give rise to six products, sulfoxide, dibenz[*c,e*][1,2]oxathiin-6-oxide, -6,6-oxide, sulfone, 2-sulfobenzoic acid, and benzothiophene-2,3-dicarboxylic acid, with the latter three compounds finally being obtained. The details of the identification of these photoproducts and photoreaction pathways for DBT are studied in the latter part of this chapter. The photodecomposition products of DBT in acetonitrile are unlikely to be distributed in nonpolar or nearly nonpolar solvents. To confirm this, the acetonitrile solution for DBT was contacted with ten-fold volumes of *n*-hexane, following photoirradiation. The photooxidized and photodecomposed compounds were not distributed into the *n*-hexane phase. This indicates that these compounds are more polar than the parent DBT, confirming the report of Zannikos et al. (1995). These results indicate that DBT was photodecomposed in acetonitrile to be converted to highly polarized compounds, which do not distribute into the nonpolar hydrocarbon phase.

The photoreactivity of 4-methyl DBT and 4,6-dimethyl DBT was also studied. In acetonitrile, the reactivity of these substituted DBTs was found to be higher than that of DBT, with the order of reactivity is DBT < 4-methyl DBT < 4,6-dimethyl DBT, as shown in **Figure 3-5**. This is the same tendency as those obtained in the oil/water two-phase system, as shown in **Figure 2-4**, thus demonstrating that the present photoprocess is also

effective for the desulfurization of these refractory compounds. The 4-methyl DBT and 4,6-dimethyl DBT were also confirmed by GC analysis to be converted to sulfoxide, sulfone, and corresponding acidic compounds, as in the case for nonsubstituted DBT. The photodecomposition rate of BT, as shown in **Figure 3-5**, was found to be faster than for DBTs, similarly in the tetradecane/water two-phase system. The photodecomposition of BTs in acetonitrile was also more rapid than that obtained in the tetradecane/water two-phase system and has already been shown in **Figure 2-4**. The photoproducts of methyl-substituted DBTs and BT were also found to be converted more polar compounds than parent compounds, as in the case for DBT. The photoproducts and reaction pathway of alkyl-substituted BTs and DBTs are also studied in detail in the latter part of this chapter.

1.3. Desulfurization of Light Oils

An organic two-phase extraction system using acetonitrile as extraction solvent, combined with photoirradiation was employed for desulfurization of actual light oils. The light oils were mixed with acetonitrile at various solution volume ratios, and were photoirradiated. When light cycle oil (LCO) is contacted with acetonitrile (acetonitrile/LCO volume ratio = 3), the resulting volume for the LCO (30%) is significantly smaller than those obtained for both CLO and LGO (95%). This is because the LCO contains a high proportion of aromatic hydrocarbons having high polarity, which are distributed into the acetonitrile phase. When water was added to the acetonitrile phase, the LCO recovery was increased to a great extent. The LCO, after contact with acetonitrile, was therefore recovered completely, in the following experiments, by the addition of an equal volume of water as that of the feed acetonitrile to the two phases at a temperature of 303 K. The dissolution of acetonitrile into the resulting light oils was thereby suppressed completely.

Figure 3-6 shows the variations in the sulfur contents of light oils with respect to the photoirradiation time, as a function of the feed acetonitrile/light oil volume ratio. The data at an irradiation time of zero are those obtained simply by mixing the two phases, and show the distribution equilibria for the sulfur contents of the two phases. In combination with photoirradiation, the desulfurization yield is shown to be much enhanced. These results demonstrate that the sulfur-containing compounds distributed into the acetonitrile are there photodecomposed efficiently, thus providing the successive removal of sulfur

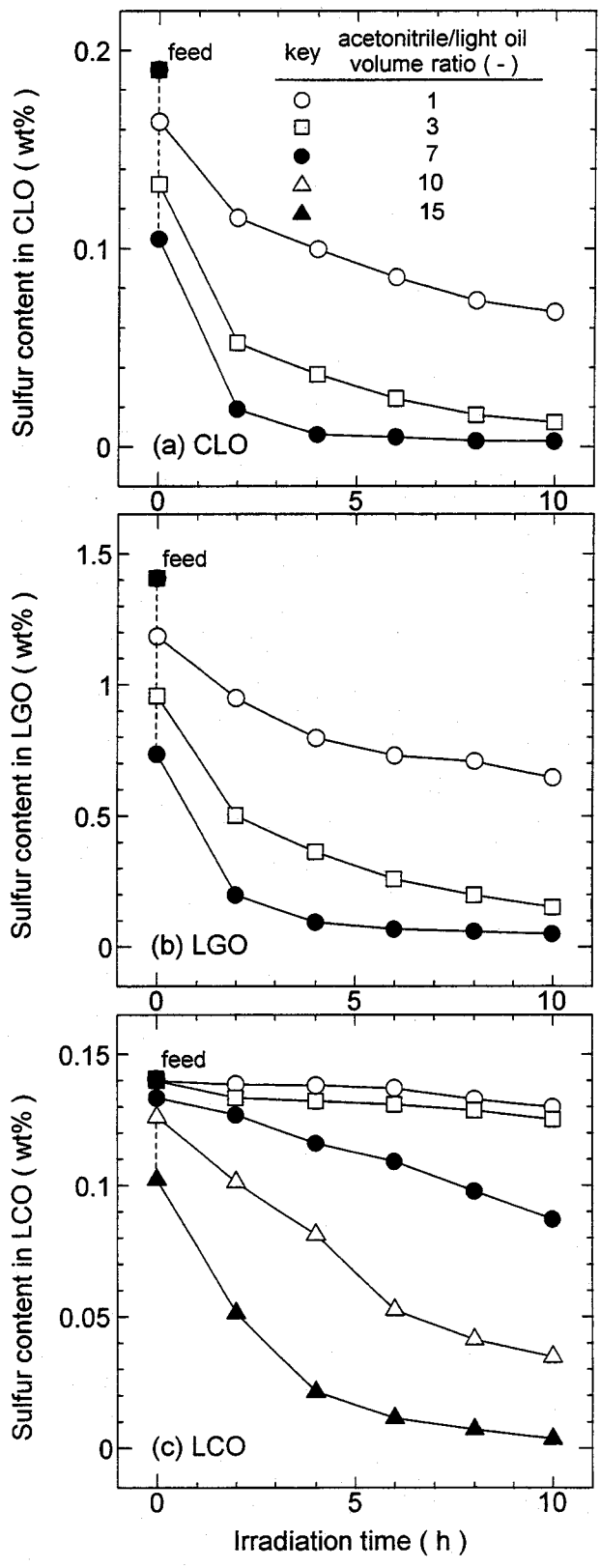

Figure 3-6. Time-course variation in the sulfur content of (a) CLO, (b) LGO, and (c) LCO, during photoirradiation of the oil/acetonitrile two-phase system, as a function of oil/acetonitrile volume ratio.

compounds from light oil to acetonitrile. For CLO, taking a higher acetonitrile/CLO volume ratio of 7, the sulfur content was found to be decreased successfully from 0.2 wt% to 0.02 wt% by only 2 h photoirradiation and to less than 0.005 wt% by 4 h photoirradiation. This sulfur content value of 0.005 wt% accords with the value now strictly regulated in Sweden and Switzerland, thus suggesting that the present process is effective for the deep desulfurization of light oil.

For LGO, simple contact with acetonitrile without photoirradiation reduced the sulfur content from 1.4 to 0.7 wt%, as shown in **Figure 3-6b**. The sulfur content of LGO was decreased to 0.2 wt% by 2 h photoirradiation and to less than 0.05 wt% by 10 h photoirradiation. The desulfurization rate for LGO in the time period 0–2 h was six-fold faster than for CLO. LGO contains a large quantity of BT and its associated derivatives (0.56 wt%); these are much more easily photodecomposed, leading to the greater apparent desulfurization rate for LGO than CLO. The desulfurization rate of LCO was rather slower than those for both CLO and LGO at lower acetonitrile/LCO volume ratios. This is because the distribution of the sulfur compounds was decreased by the addition of water following the photoirradiation. The desulfurization of LCO was, however, much enhanced with an increase in the acetonitrile volume ratio, as shown in **Figure 3-6c**. At a volume ratio of 15, the sulfur content of LCO was decreased successfully to less than 0.005 wt%. Thus, the present process is shown to be also effective for the deep desulfurization of aromatic rich light oils.

The values for the sulfur distribution ratio, D_s , for acetonitrile/light oil two phases, following simple extraction and photoirradiation (2 h), are shown in **Figure 3-7**. The D_s is defined as follows:

$$D_s = \frac{[\text{sulfur}]_{\text{in acetonitrile}}}{[\text{sulfur}]_{\text{in light oil}}} \quad (3-1)$$

Although expected, the values of D_s following simple extraction are small, the ratios increased with increasing volume ratio, when photoirradiation was applied. For example, taking a volume ratio of 7, the values of D_s are increased 11-fold in CLO and 9-fold in LGO as compared for no photoirradiation. This indicates that the photoreaction of BTs and DBTs in acetonitrile proceeds more effectively with increasing acetonitrile volume

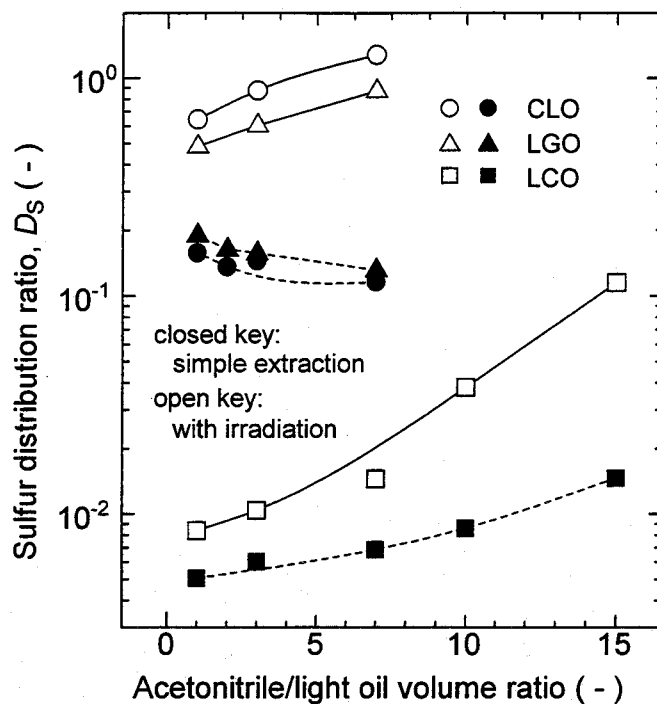

Figure 3-7. Effect of the photoirradiation (2 h) on the sulfur distribution ratio, D_s , in (a) CLO, (b) LGO, and (c) LCO/acetonitrile systems. D_s : ratio of the total sulfur content in acetonitrile and in light oils.

added. This may probably be caused by a decrease in the photo-scattering and light exclusion by the light oil phase, since the photoreaction proceeds mainly in the acetonitrile phase. The values for D_s for CLO is seen to be slightly higher than for LGO. This is because that the LGO contains a higher proportion of bicyclic aromatic hydrocarbons. The values of D_s for LCO were rather lower than those for CLO and LGO, since in the desulfurization for LCO, water addition is required to enhance the recovery of LCO after the photoreaction. The values were, however, increased with an increase in the acetonitrile volume. From these results, the present process is shown to be more effective for paraffinic light oils than aromatic rich ones.

Variations in the composition of the sulfur-containing compounds in CLO, LGO, and LCO, following extraction and photoirradiation, were shown in **Table 3-2**, and the data were plotted against the carbon number of the alkyl substituents in **Figure 3-1**. The remaining percentages for BTs and DBTs in light oils, following photoirradiation, were 18% and 38% for CLO, 22% and 45% for LGO, and 1.5% and 3.5% for LCO, respectively. These results demonstrate that the BTs are desulfurized more easily than DBTs by the present process. The remaining percentage for both the BTs and DBTs,

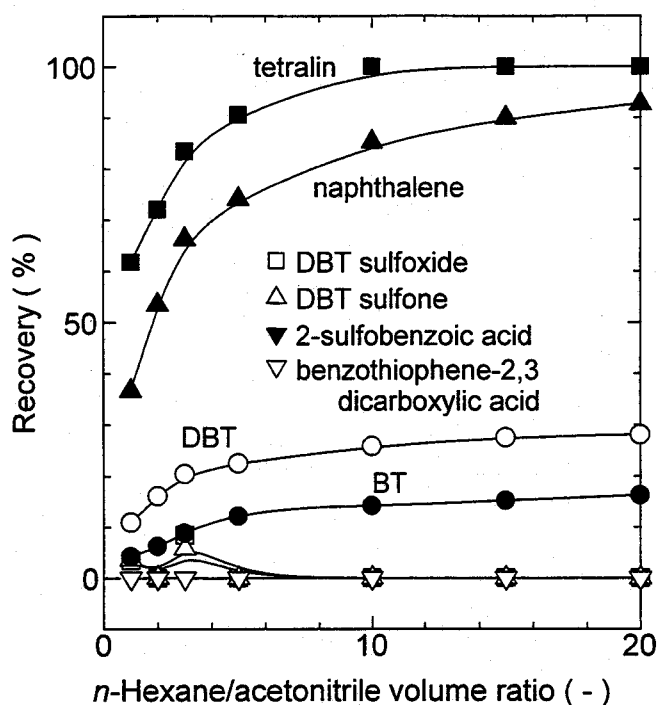

Figure 3-8. Extractability of aromatic hydrocarbons and DBT, BT, and their photodecomposed products by *n*-hexane.

following photoirradiation, has a tendency to increase with increasing carbon number of the alkyl substituents, as shown in **Figure 3-1**, and shows nearly parallel lines with those obtained without photoirradiation. These findings reveal that photoreactivities of sulfur-containing compounds with different carbon numbers are not so very much different from each other, and the polarity of the compounds governs the removal of sulfur compounds from light oil to acetonitrile. In the present desulfurization process, the highly-substituted DBTs are shown to be the most difficult compounds to be desulfurized, as was also found in the oil/water two-phase system.

1.4. Recovery of Aromatics from Acetonitrile and Effect of Addition of Water

By contacting the light oils with acetonitrile, a high proportion of sulfur-free aromatic hydrocarbons in light oils are also distributed into the acetonitrile phase together with the sulfur-containing compounds, as shown in **Table 3-1**. In order to recover the aromatics from the acetonitrile phase, a liquid-liquid extraction procedure was employed, using light paraffinic solvent (*n*-hexane) as stripping solvent. Tetralin (100 mM) and naphthalene (50 mM), being typical of monocyclic and bicyclic aromatics, respectively, were dissolved in acetonitrile solution together with DBT, BT, and their photoproducts (1 mM). These were then extracted with *n*-hexane at a temperature of 298 K for 10 min. **Figure 3-8**

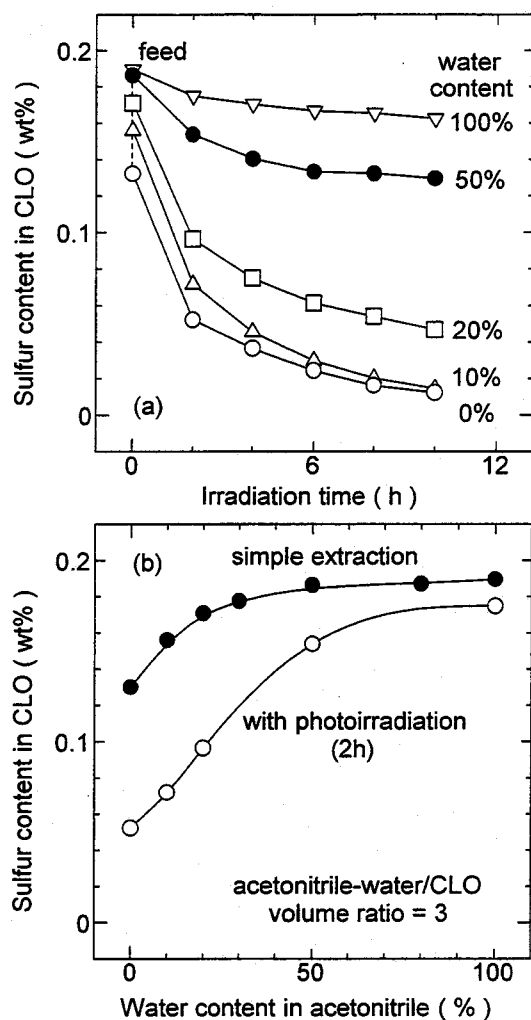

Figure 3-9. Effect of the addition of water in acetonitrile on (a) the time-course variation of sulfur content in the commercial light oil (CLO) and (b) the sulfur content in the CLO at 2 h in the case with and without photoirradiation.

shows the extractability of these compounds as a function of the *n*-hexane/acetonitrile volume ratio. At volume ratios of up to 10, sulfur-free aromatics recoveries of over 85% were obtained for naphthalene and 100% for tetralin. Similar results were also obtained for the extraction, when using *n*-heptane and *n*-pentane. Although the DBT and BT also tend to be extracted, the photodecomposed products for DBT and BT were hardly extracted. Hexane and acetonitrile can be easily separated from the aromatics and the photodecomposed DBTs and BTs by evaporation or distillation and may be reused in the desulfurization process.

When contacted, 5% of acetonitrile is actually distributed into the light oil phase. Some water is usually added to the polar solvents such as DMSO, sulfolane and

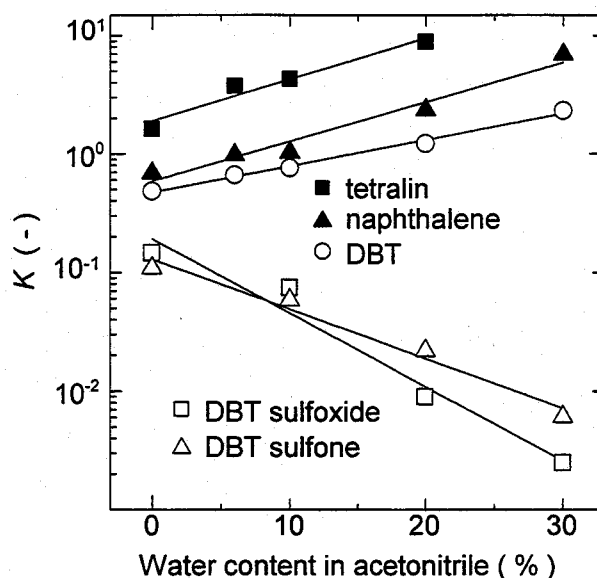

Figure 3-10. Effect of the addition of water to acetonitrile on the distribution coefficient, K , of aromatic hydrocarbons and DBT derivatives.

tetraethylene glycol to improve the selectivity in the separation and purification of the aromatics (Bailes, 1983). Thus, the effects of the addition of water on the desulfurization process and on the recovery of the aromatics were also investigated. Phase separation was found to be improved and dissolution of the acetonitrile into the light oil was suppressed by using mixed solvents. This was especially the case with the addition of 10–20 vol% of water. The desulfurization yield of CLO was decreased by increasing water content, as shown in **Figure 3-9**. When the DBT was dissolved in homogeneous acetonitrile solution and photoirradiated, the photoreactivity of DBT in mixed solvents of acetonitrile/water, however, was not influenced by the addition of water less than 20%. The decrease in the desulfurization yield at water contents of 0–20 vol% is therefore attributed to a decrease in the simple distribution of the sulfur compounds into the mixed solvent phase. The desulfurization of light oil by photoirradiation with 10–20 vol% water-acetonitrile mixed solvent was, therefore, found to be fairly feasible.

It is important to extract as much of the aromatics as possible into the *n*-hexane, while leaving as much of the sulfur-containing compounds as possible in the acetonitrile/water solution. To study this, DBT/acetonitrile ($[DBT]_{\text{initial}} = 15 \text{ mM}$) solution was photoirradiated for 3 h and then water was added to the solution. The solutions were then contacted with an equal volume of *n*-hexane. **Figure 3-10** shows the effect of the water content on the distribution coefficient, K , defined as the ratio of the concentration of

the aromatic hydrocarbons and DBT derivatives in *n*-hexane to those in the acetonitrile-water mixture. With increasing water content, the values of *K* for the aromatic hydrocarbons are increased, as reported by Natusch and Tomkins (1978), while the values for DBT sulfoxide and sulfone, which are main photoproducts for DBT, are decreased. This is probably caused by the increase in the polarity of the acetonitrile phase by the addition of water. Thus, in this way, the quantitative recovery of pure aromatics from the solvent phase is more easily effected. On distilling the resulting mixed solvent following re-extraction, an azeotropic mixture (86% acetonitrile and 14% water, 349 K) containing no sulfur compounds was obtained. This means that the pure azeotropic mixture can be recovered, and reused as the extraction solvent for further desulfurization.

1.5. Organization of the Overall Desulfurization Process

An basic flow scheme of the overall process involving the extraction and photodecomposition of sulfur-containing compounds, the recovery of aromatics, and then solvent recovery is given in **Figure 3-11**. The process sequence is follows: (1) feed light oil and azeotropic mixture are introduced to the photoreactor for desulfurization. (2) The extraction phase (acetonitrile phase) is sent to the aromatics extractor. The aromatics compounds are extracted by the light paraffinic solvent such as *n*-hexane, leaving the photodecomposed sulfur-containing compounds. (3) The light paraffinic solvent is mixed with desulfurized light oil and easily be recovered by distillation, and therefore, all the sulfur-free aromatics from the feed are mixed with the raffinate light oil phase. By choosing an appropriate mixture ratio of the solvent and desulfurized light oil, the raffinate containing a required amount of aromatics can be obtained at the bottom of the distillation tower. (4) The water is used to wash the raffinate for recovery of dissolved acetonitrile, and the water phase is then mixed with the remaining extraction phase (acetonitrile) which contains sulfur-containing compounds. (5) Pure azeotropic mixture are recovered by the distillation, and the pure water is recovered by the sequential distillation, leaving the photooxidized and photodecomposed sulfur-containing compounds at the bottom. (6) The water can be recovered and reused for the washing solvent of light oil raffinate. In this overall process, therefore, the extraction phase (acetonitrile-water azeotropic mixture), aromatic recovery solvent (*n*-paraffin), and water can be recirculated for further desulfurization.

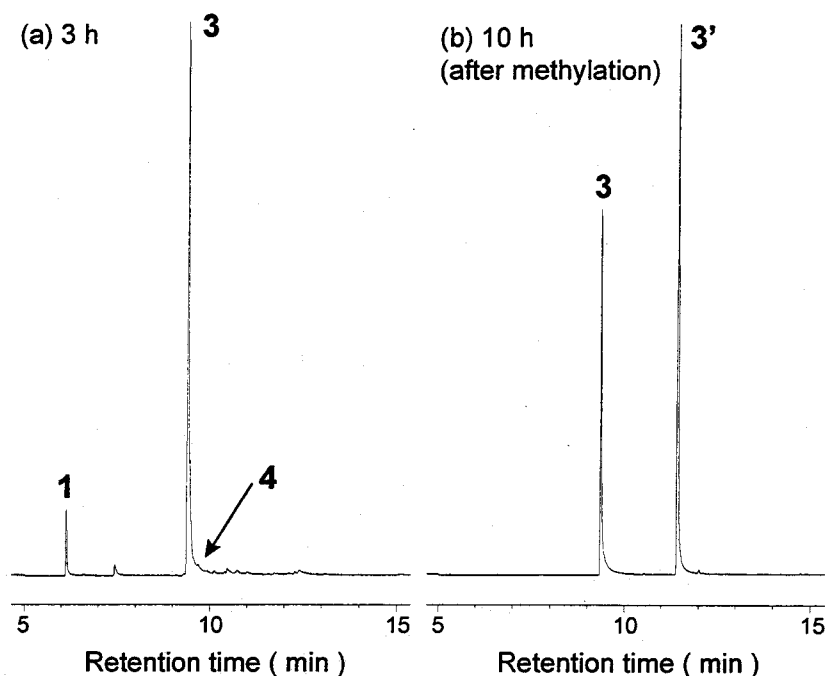

Figure 3-12. GC-AED chromatograms (sulfur, 181 nm) for acetonitrile solution, containing initially 11 mM of BT, following (a) 3 h photoirradiation and (b) 10 h photoirradiation and methylation.

2. Identification of the Desulfurization Products and Reaction Pathways for Sulfur-Containing Compounds

2.1. Photoproducts and Reaction Pathway for Benzothiophene

The photoproducts of benzothiophene (BT, 1) in acetonitrile were first studied. **Figure 3-12a** shows the sulfur-specific GC-AED chromatogram of acetonitrile solution, containing initially 11 mM of BT 1, following 3 h photoirradiation. The quantity of BT 1 eluting at 6.1 min decreased, and the peak 3 at 9.3 min and several minor peaks newly appeared. Following 10 h photoirradiation, only the peak 3 remained. When 1 M NaOH aqueous solution contacts the resulting chloroform solution, the peak 3 on the gas chromatogram disappeared. By the analyses of reverse-phase HPLC, a peak coeluted with mobile phase was detected during photoirradiation, as shown in **Figure 3-13**. These results indicate that peak 3 is a water-soluble acidic compound. **Figure 3-12b** shows the gas chromatogram of acetonitrile solution obtained by 10 h photoirradiation and methylation with diazomethane. The magnitude of peak 3 decreased, and a new peak 3' appeared at 11.4 min, thus indicating that the peak 3' is the methylated derivative of the peak 3 compound.

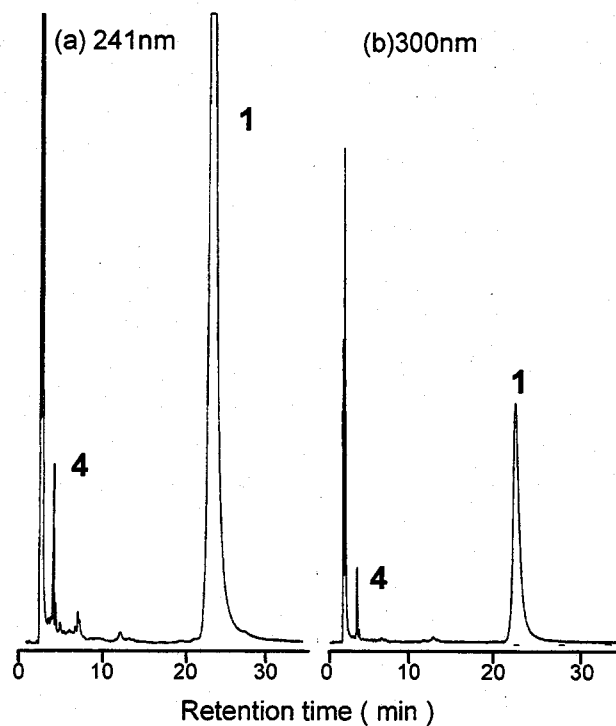

Figure 3-13. HPLC chromatograms obtained by monitoring (a) 241 nm and (b) 300 nm, for acetonitrile solution, containing initially 11 mM of BT, following 4 h photoirradiation.

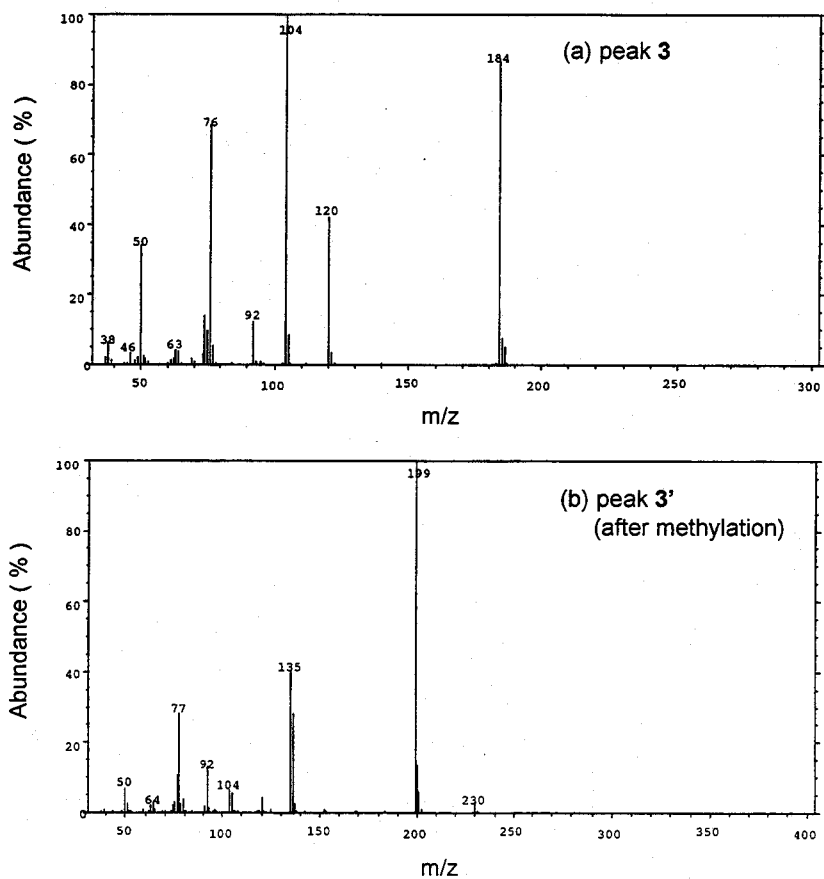

Figure 3-14. EI mass spectra for (a) peak 3 and (b) peak 3', as shown in **Figure 3-12**.

Scheme 3-1. MS Fragmentation Pattern for (a) 2-Sulfobenzoyl Anhydride 3 and (b) 2-Sulfobenzoyl Dimethyl Ester 3'

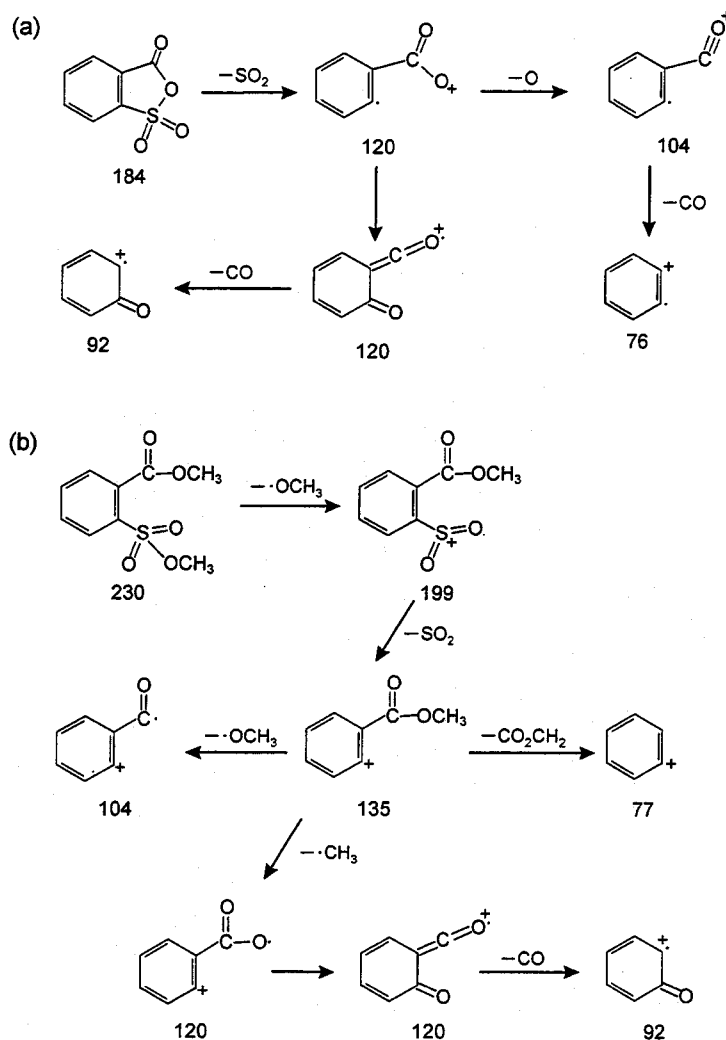

Figure 3-14 shows the EI mass spectra for the two peaks 3 and 3'. The peak 3' exhibits a weak molecular ion at m/z 230 and a major fragment ion at m/z 199. The first fragmentation of m/z 230-199 (31) and the subsequent fragmentation of m/z 199-135 (64) are each attributable to the loss of OCH_3 (31) and SO_2 (64), respectively. These results, therefore, strongly suggest that the peak 3' molecule has the function of methyl sulfonate. Peak 3 exhibits a molecular ion at m/z 184 and major stable fragment ion at m/z 104. The first fragmentation at m/z 184-120 (64) seems to occur according to the loss of SO_2 (64). The formation process of a major ion at m/z 104 is probably attributable to the loss of O (16) from the fragment ion at m/z 120. The ions at m/z 92 and 76 are formed by the loss of CO (28) from the ions at m/z 120 and 104, respectively. These fragmentations with the extrusion of CO and O suggest that an ester bond is involved in the molecular structure. Considering these results, the fragmentation process for the peak 3 compound

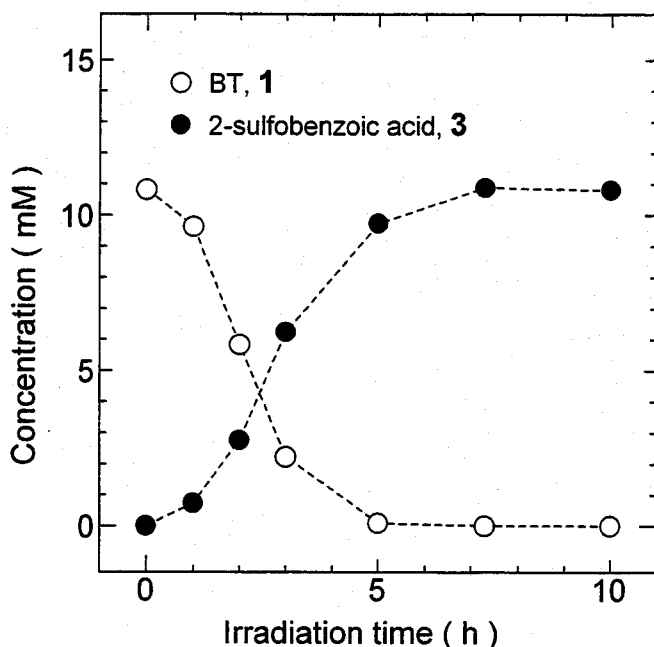

Figure 3-15. The variation in the concentrations of BT 1 and 2-sulfobenzoic acid 3 in acetonitrile with photoirradiation time.

can be explained well according to **Scheme 3-1a**. Peak 3 is therefore identified as 2-sulfobenzoic acid anhydride, and this mass spectrum agrees well with that of the standard material. Likewise, the fragmentation pattern of 2-sulfobenzoic acid dimethyl ester 3' is explained, according to **Scheme 3-1b**. Although the methylation of 3 gives rise to a hydrolyzed dimethylated ester, the GC analysis detects a peak 3 component in dehydrated form. This is because the hydrolyzed 2-sulfobenzoic acid is thermally dehydrated on GC injection. The 2-sulfobenzoic acid formed by photoreaction of BT 1 is therefore contained in acetonitrile in the hydrolyzed form.

Figure 3-15 shows the variation in the concentrations of BT 1 and 2-sulfobenzoic acid 3 with reaction time. Ten hours of photoirradiation convert the BT 1 quantitatively to 2-sulfobenzoic acid 3. Andersson and Bobinger (1992) have reported that in methanol-water with irradiation at $\lambda > 300$ nm, BT 1 is photooxidized to form 2-sulfobenzoic acid 3 via benzothiophene-2,3-dione 4. In acetonitrile, a peak attributed to a trace amount of 4 was detected by the GC-AED analysis at 9.4 min, as shown in **Figure 3-12a**, and by the HPLC analysis at 4 min, as shown in **Figure 3-13**. The photoreaction of BT 1 in acetonitrile is therefore also likely to progress via compound 4. To clarify the pathway from 4 to 3, acetonitrile solution, containing 4 (5.4 mM), was photoirradiated as

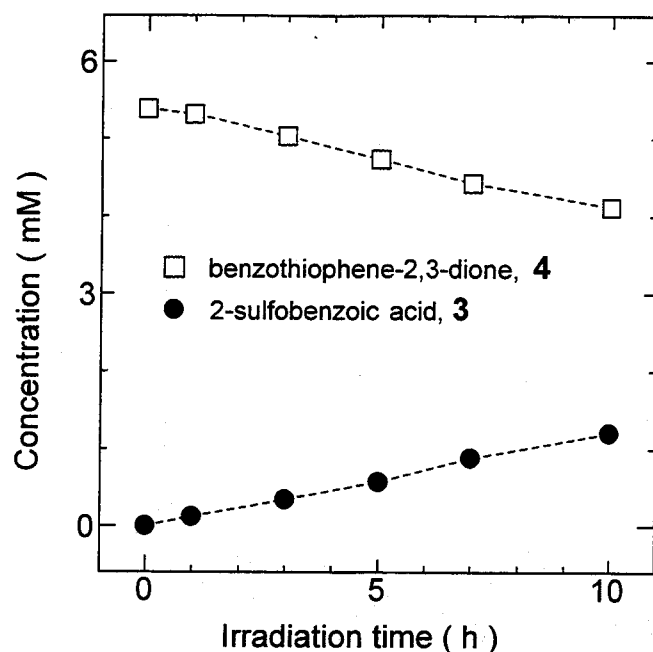
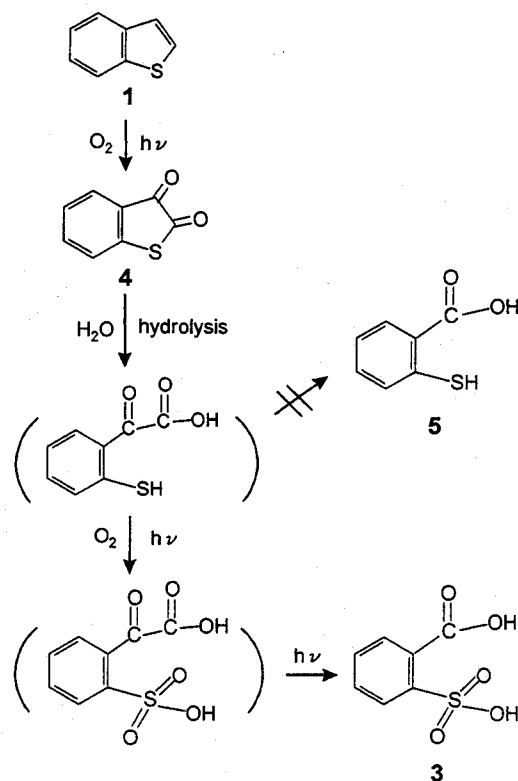

Figure 3-16. The variation in the concentrations of benzothiophene-2,3-dione **4** and 2-sulfobenzoic acid **3** in acetonitrile with photoirradiation time.

Scheme 3-2. Reaction Pathways for BT 1 in Acetonitrile by Photoirradiation



the starting material. The variation in the concentrations of **4** and **3** with reaction time is shown in **Figure 3-16**. The quantity of **4** decreased with irradiation time, and 2-sulfobenzoic acid **3** was formed in quantitative amounts, up to the 10 h photoirradiation.

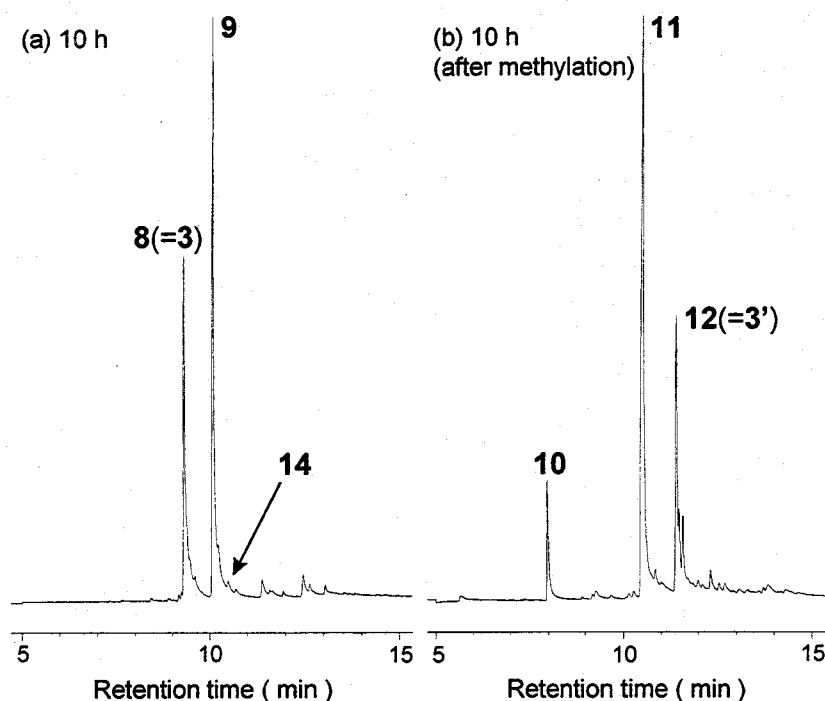

Figure 3-17. GC-AED chromatograms (sulfur, 181 nm) for acetonitrile solution, containing initially 12 mM of 3-methyl BT 6, following (a) 10 h photoirradiation and (b) 10 h photoirradiation and methylation.

Thus, in acetonitrile, the photoreaction from BT 1 to 2-sulfobenzoic acid 3 is shown to progress also via benzothiophene-2,3-dione 4.

Andersson and Bobinger (1992) have suggested that the overall reaction from 4 to 3 occurs first in the order of hydrolysis, then by loss of carbon monoxide, and finally by oxidation of the mercapto group. In the present experiments, thiosalicylic acid 5 (standard material elutes at 9.1 min) was not observed by GC-AED analysis, thus indicating that, in the present process, hydrolysis and the oxidation of mercapto groups precede the loss of CO. The photoreaction rate from 4 to 3 was found to slightly increase with increasing water concentration, and the methyl ester of hydrolyzed 4 was not detected by GC analysis, thus suggesting that the hydrolysis of 4 is the rate-determining step. The reaction from 4 to 3 is therefore likely to be initiated by the hydrolysis of 4, after which the sulfur atom is photooxidized, followed by the loss of CO, and a final conversion to 3. The reaction pathway for BT 1 is thus as proposed in **Scheme 3-2**.

2.2. Photoproducts and Reaction Pathways for 3-Methyl and 2,3-Dimethyl BT

Alkyl-substituted BTs are the main constituents of the sulfur-containing compounds in light oils. The photoproducts for these compounds were then studied using 3-methyl

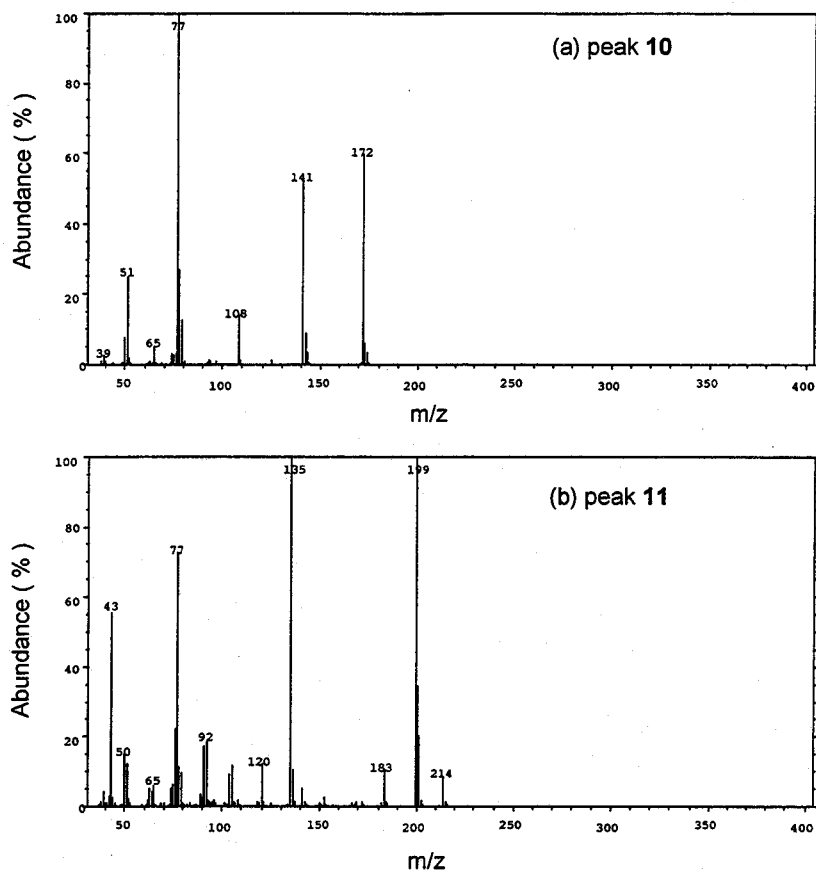
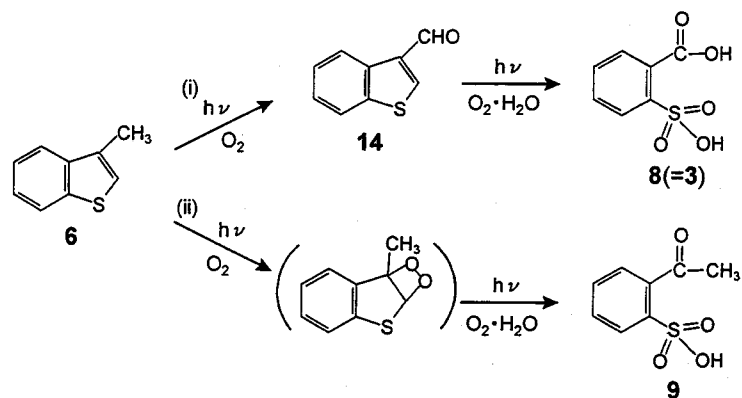

Figure 3-18. EI mass spectra for (a) peak 10 and (b) peak 11, as shown in **Figure 3-17**.

BT 6 and 2,3-dimethyl BT 7 as model compounds. **Figure 3-17a** shows the sulfur-specific GC-AED chromatogram of the resulting acetonitrile solution, initially containing 12 mM 3-methyl BT 6, following 10 h photoirradiation. During photoirradiation, a large number of peaks appeared over a retention time range of 9-13 min, but finally only two major peaks of 8 and 9 remained at 9.3 and 10.1 min, respectively. The mass spectrum for 8 was found to be the same as that for 2-sulfobenzoic acid anhydride 3. The mass spectrum for 9 exhibits a molecular ion at m/z 183 and a fragment ion at m/z 105, 91, and 43, but this compound could not be identified on the basis of the mass spectrum alone. The gas chromatogram obtained following methylation is shown in **Figure 3-17b**. Three major peaks 10 (7.9 min), 11 (10.5 min), and 12 (11.4 min) appeared. The mass spectrum of 12 matches well with that of 2-sulfobenzoic acid methyl ester 3'. The spectra of 10 and 11 are shown in **Figure 3-18**. The spectrum for 10 shows a molecular ion at m/z 172 and fragment ions at 141 and 77. The fragmentations of 172-141 (31) and 141-77 (64) are attributable to the losses of OCH_3 (31) and SO_2 (64), and thus 10 is

Scheme 3-4. Reaction Pathways for 3-Methyl BT 6 in Acetonitrile by Photoirradiation



routes, as shown in **Scheme 3-4**: (i) oxidation of the methyl function and (ii) oxidation of the 2- and/or 3-position (not including the oxidation of the methyl function). The actual formation process for benzenesulfonic acid **13**, however, cannot be determined.

Photoirradiation to the acetonitrile solution, containing 2,3-dimethyl BT **7**, gave a gas chromatogram similar to that for 3-methyl BT **6**. Products are identified as 2-sulfobenzoylbenzoic acid anhydride **8**, benzenesulfonic acid **13**, and 2-acetylbenzenesulfonic acid **9**, obtained following 10 h photoirradiation with relative yields of 21%, 11%, and 53%, respectively. During photoirradiation, trace quantities of 2-methylbenzothiofene-3-carbaldehyde (m/z 176 (M^+)), 3-methylbenzothiofene-2-carbaldehyde (m/z 176 (M^+)), and benzothiofene-2,3-dicarbaldehyde (m/z 199 (M^+)) were detected. The photoreaction of 2,3-dimethyl BT is therefore likely to progress also via two alternative routes, as for 3-methyl BT.

2.3. Photoproducts and Reaction Pathway for Dibenzothiophene

An acetonitrile solution containing 27 mM dibenzothiophene (DBT) **2** was photoirradiated. **Figure 3-19** shows reverse-phase HPLC chromatogram, obtained by monitoring at 241 nm, for the samples following 4 h photoirradiation of the acetonitrile solution for DBT. With a decrease in the DBT concentration, new peaks were eluted at around 3, 5–6, and 8 min. These peaks were confirmed to be attributable to DBT sulfoxide, DBT sulfone, dibenz[*c,e*][1,2]oxathiin-6-oxide, by comparing the retention times with those of the standard materials. A large peak, shown by “a,” co-eluted with the mobile phase, was seen to appear at the lower retention time. As shown in **Figure 3-20**, the peak a is seen to be separated more clearly and are retarded by a decreasing pH of

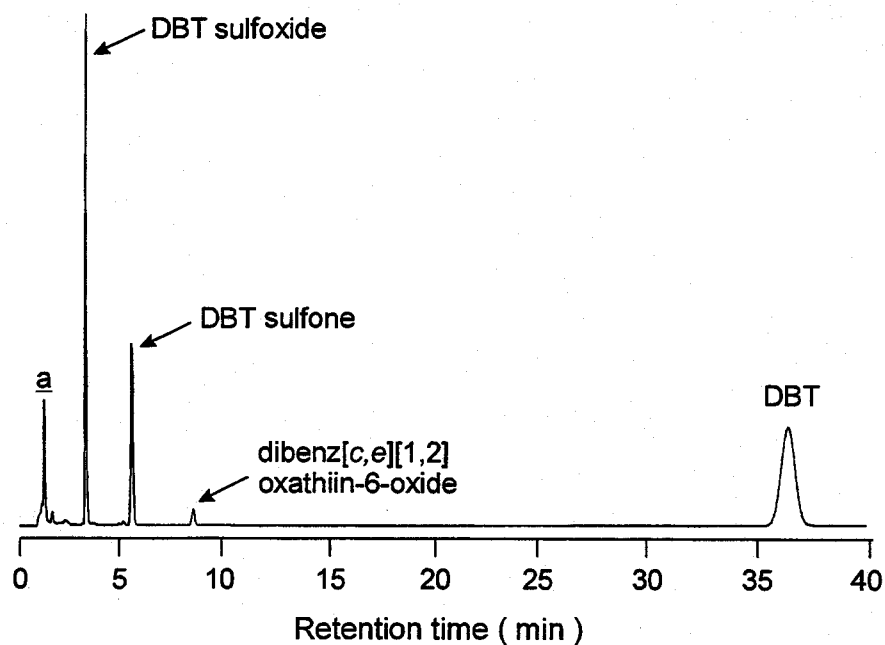

Figure 3-19. Reverse-phase HPLC chromatogram obtained by monitoring at 241 nm, for the samples obtained by 4 h photoirradiation of the DBT/acetonitrile ($[DBT]_{\text{initial}} = 11 \text{ mM}$) solution.

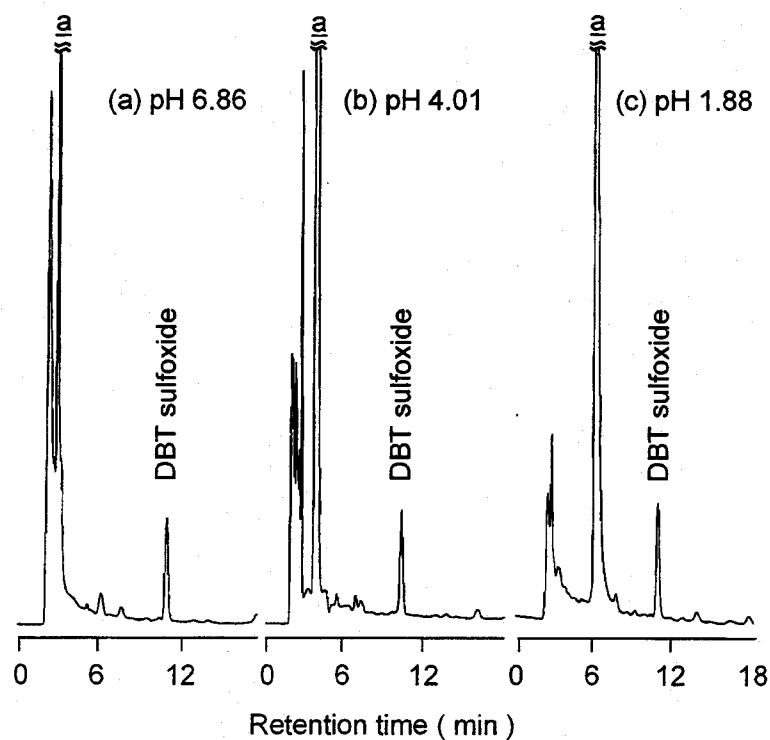

Figure 3-20. Reverse-phase liquid chromatograms for HPLC analysis, obtained by monitoring at 340 nm, for the sample obtained by 4 h photoirradiation of the DBT/acetonitrile ($[DBT]_{\text{initial}} = 27 \text{ mM}$) solution, eluted isocratically by a 30% acetonitrile in water solution. pH: (a) 6.86 (phosphate buffer), (b) 4.01 (phthalate buffer) (c) 1.88 (KH_2PO_4 , 5 mM; HClO_4 , 0.1%).

the eluent, thus indicating that these are acidic compounds. The eluting compounds **a** showed a broad absorption at around 340 nm, and it was confirmed also, by ion chromatography analysis, that SO_4^{2-} and SO_3^{2-} ions were not produced during the photoirradiation. These findings indicate that the peak **a** compounds are likely to consist of mono- or bicyclic aromatic compounds, conjugated with an acidic substituent (e.g. carboxylic acid or sulfonic acid).

Sulfur-specific GC-AED chromatograms for the acetonitrile solution, following 7 and 30 h photoirradiation, are shown in **Figure 3-21a** and **b**. Following 7 h photoirradiation, six peaks including residual DBT **2** appeared. Sulfoxide **20** was also formed, but did not appear on the chromatogram, since this is easily pyrolyzed on GC injection (Olson et al., 1993; Vignier et al., 1983). Several peaks on the gas chromatogram disappeared following further photoirradiation, and following 30 h photoirradiation only three peaks **15** (9.3 min), **16** (12.3 min), and **19** (16.1 min) remained. The mass spectrum of **15** closely resembles that of 2-sulfobenzoic acid anhydride **3**, and the spectrum of **19** also matches very well with the reported spectrum for DBT sulfone (Fields and Meyersson, 1966; Olson et al., 1993). The mass spectrum of the peak **16** is shown in **Figure 3-22a**. The spectrum of peak **16** consisted of a stable molecular ion at m/z 204 and other major ions at m/z 160 and 132. The fragmentations of m/z 204-160 (44) and m/z 160-132 (28) seem to be caused respectively by the loss of CO_2 (44) and CO (28), which are usually found in the mass fragmentation for phthalic acid anhydride (Emery, 1960; McLafferty and Gohlke, 1959).

To identify the compound **16**, the resulting solution obtained in 30 h photoirradiation was methylated by diazomethane. The gas chromatogram obtained is shown in **Figure 3-21c**. It is significant that the peaks **15** and **16** have disappeared, and new peaks **15'** (2-sulfobenzoic acid dimethyl ester) at 11.4 min and **16'** at 14.1 min have appeared, thus indicating that the peak **16'** is the methylated derivative of the peak **16** compound. The mass spectrum for peak **16'** is shown in **Figure 3-22b**, and consists of a molecular ion at m/z 250 and a major fragment ion at m/z 219. This first fragmentation seems to be attributable to the loss of OCH_3 (31). Thus, methylation is likely to occur for the hydrogen atom on hydrolyzed dicarboxylic acid groups, as in the case of 2-sulfobenzoic

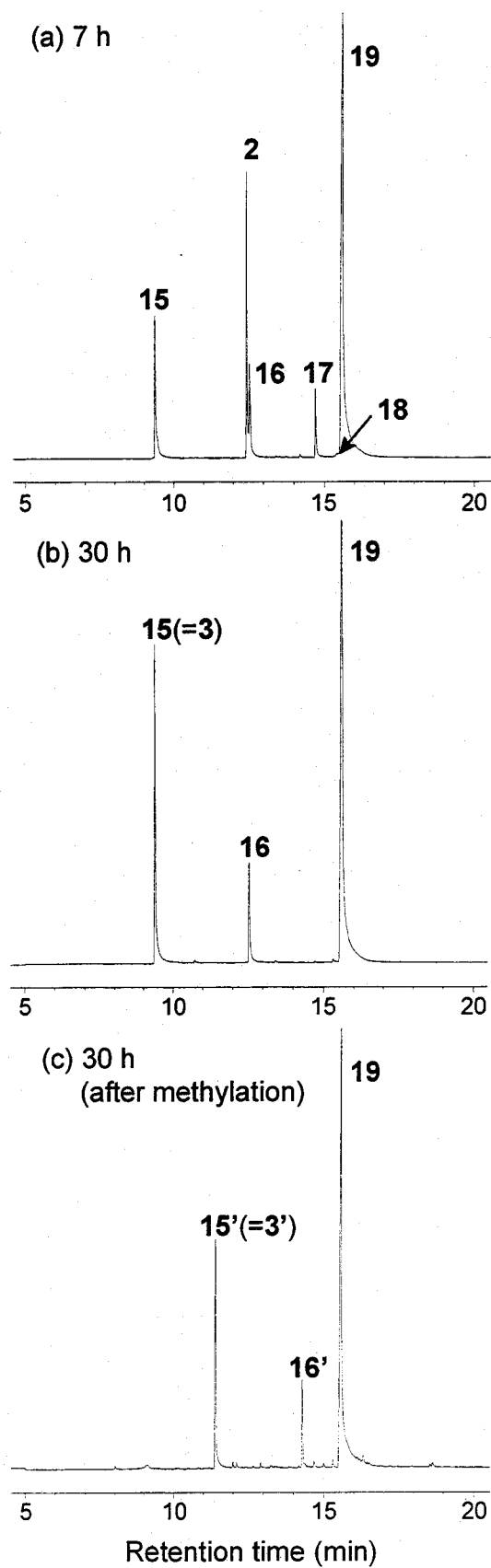

Figure 3-21. GC-AED chromatograms (sulfur, 181 nm) for acetonitrile solution, containing initially 27 mM of DBT, following (a) 7 h and (b) 30 h photoirradiation and (c) 30 h photoirradiation and methylation.

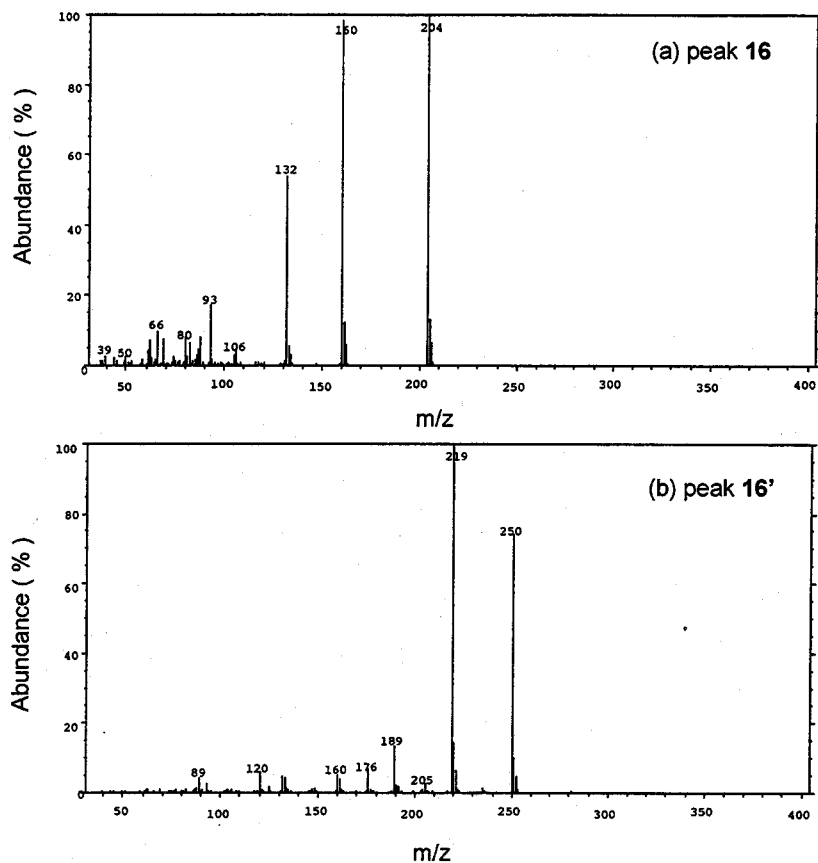

Figure 3-22. EI mass spectra for (a) peak 16 and (b) peak 16', as shown in **Figure 3-21**.

acid. In addition, the frequency of many fragment ions at less than m/z 219 is very small, thus suggesting that stable aromatic rings are conjugated with dicarboxylic acid. Considering the mass spectroscopic data, the fragmentations for the components 16 and 16' can be explained well by the fragmentation patterns, according to **Scheme 3-5**. Compound 16 is therefore identified as benzothiophene-2,3-dicarboxylic acid anhydride. The mass spectrum obtained for 16 agrees well with that of reported standard materials (Reinecke et al., 1981). The mass spectra of the other peaks appearing on the gas chromatogram shown in **Figure 3-21a** show molecular ions of m/z 216 for 17 (closely resembling 19) and m/z 232 for 18, which are consistent with those of reported standard materials (Hanson and Kemp, 1981; Fields and Meyersson, 1966), and are thus identified as dibenz[*c,e*]oxathiin-6-oxide 17 and -6,6-dioxide 18.

Figure 3-23 shows the time course variation in the concentrations of DBT 2 and the identified photoproducts. With increasing photoirradiation time, DBT 2 decreases and

Scheme 3-5. MS Fragmentation Pattern for (a) Benzothiophene-2,3-Dicarboxylic Acid Anhydride 16 and (b) Benzothiophene-2,3-Dicarboxylic Acid Dimethyl Ester 16'

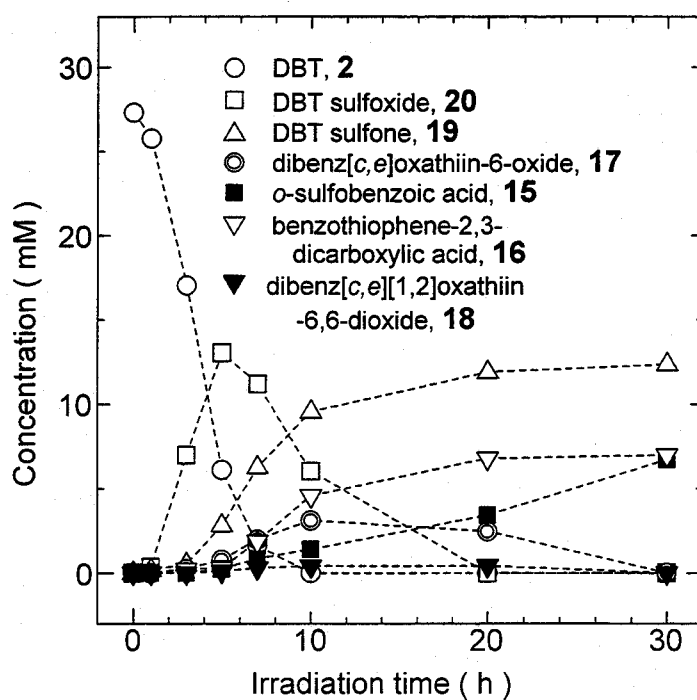
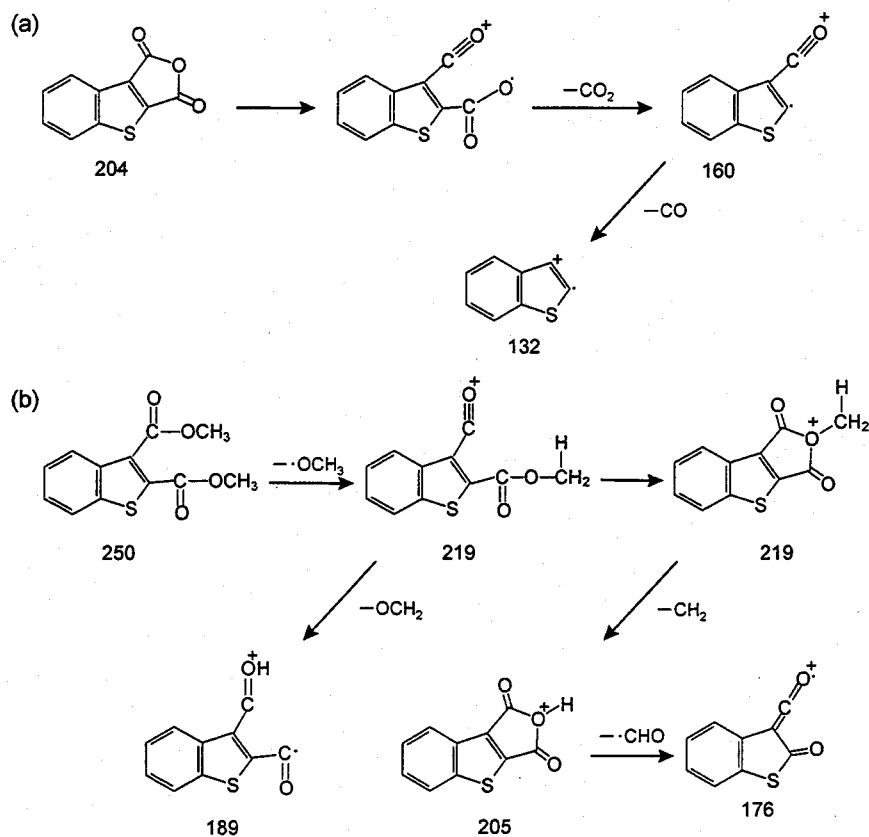
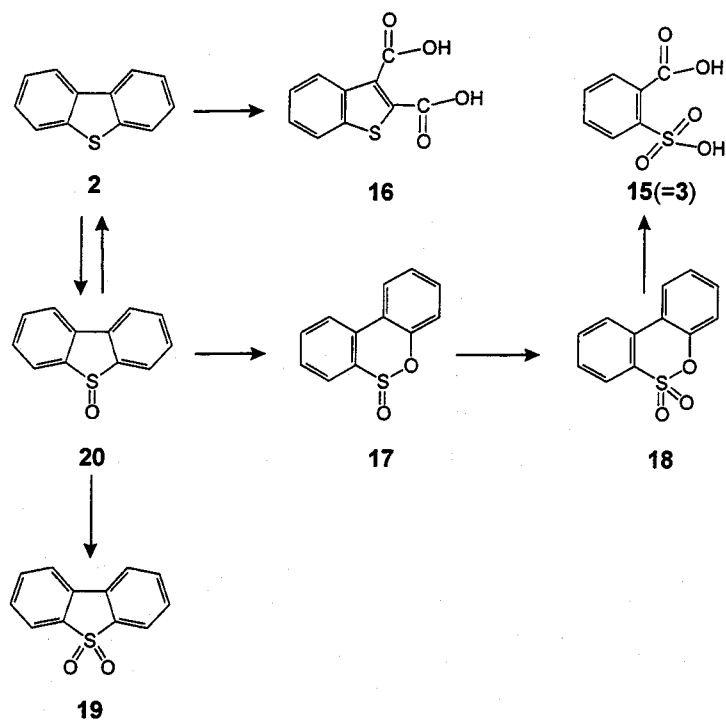

Figure 3-23. The variation in the concentrations of DBT 2 and its photoproducts in acetonitrile with photoirradiation time.

Scheme 3-6. Reaction Pathways for DBT 2 in Acetonitrile by Photoirradiation



the concentration of sulfoxide **20** starts to increase. The concentration of sulfoxide **20** then starts to decrease owing to the formation of other compounds. **15**, **16**, and **19** were finally obtained with yields of 25%, 26%, and 45%, respectively. The overall reaction pathway for the photoreaction of DBT **2** can therefore be described, as shown in **Scheme 3-6**. Only compound **16**, of which the sulfur atom is not oxygenated, is likely to be directly formed from DBT. To confirm this, photoirradiation of the acetonitrile solution, containing DBT sulfoxide **20** (containing sulfone impurity 10%) as the starting material, was carried out. **Figure 3-24** shows the time course variation in the concentrations of DBT sulfoxide **20** and the products. The concentration of **20** decreases with photoirradiation time, and those of **19** and **17** start to increase. Compound **17** then decreases and **18** increases, such that at the end of photoirradiation only **15**, **16**, and **19** remain. During photoirradiation, DBT **2** also appeared, caused by the direct photodeoxygenation of **20** (Jenks et al., 1994a; Wan and Jenks, 1995; Gregory et al., 1997). Thus, the results obtained are consistent with the proposed pathway shown in **Scheme 3-6**. When, however, compound **20** was used as the starting material, the relative yields for the final photoproducts were as follows: **15**, 50%; **16**, 21%; **19**, 24%.

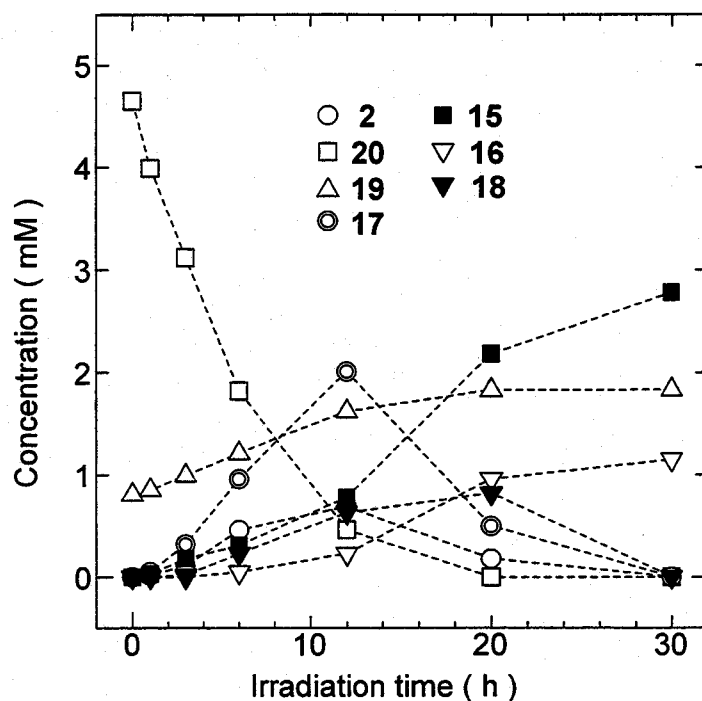

Figure 3-24. The variation in the concentrations of DBT sulfoxide **20** and its photoproducts in acetonitrile with photoirradiation time.

The yield of sulfone **19** was lower than that for the case where DBT **2** was used as starting material.

In the direct photooxidation of sulfides with molecular oxygen, the peroxidic intermediates (sulfide-oxygen charge-transfer intermediates) are formed initially (Akasaka et al., 1987; Tezuka et al., 1978). Since these intermediates are highly reactive oxidizing agents, they can oxidize other sulfides and sulfoxides to the corresponding sulfoxide and sulfone (Liang et al., 1983). Under the present experimental conditions, DBT-oxygen charge-transfer intermediates formed are also likely to be involved in the oxidation from **20** to **19**. In the case where sulfoxide **20** was employed, the formation of intermediates was less than that when DBT was used as the starting material, resulting in a lower yield of sulfone **19**.

The formation process for benzothiophene-2,3-dicarboxylic acid **16** was examined. Usually, singlet oxygen ($^1\text{O}_2$) has several crucial roles in the photooxygenation reaction. Since $^1\text{O}_2$ is a strong oxidizing agent, naphthalene and anthracene are oxygenated to form carbonyl compounds (Foote, 1968; Kearns, 1971). Since the formation of $^1\text{O}_2$ requires the photosensitization of O_2 , several photoproducts must qualify as a photosensitizer for O_2 . To confirm this, the effect of the addition of photoproducts on the formation of **16**

Table 3-3. Effect of the Addition of Photoproducts on the Conversion of DBT 2 and Formation of Benzothiophene-2,3-dicarboxylic Acid 16 and DBT Sulfoxide 20 ($[2]_{\text{initial}}$ and the Addition of Photoproducts = 27 mM, Irradiation Time = 3 h)

addition	conversion of 2 (%)	yield of 16 (%)	yield of 20 (%)
no addition	37.7	0.8	25.5
15	36.1	0.9	24.5
17	37.8	0.9	24.8
18	36.4	1.2	23.1
19	90.0	11.9	51.2
20	34.0	0.6	

Scheme 3-7. Reaction Pathways (a) from DBT 2 to Benzothiophene-2,3-dicarboxylic Acid 16 and (b) from Dibenz[*c,e*][1,2]oxathiin-6,6-dioxide 18 to 2-Sulfobenzoic Acid 15

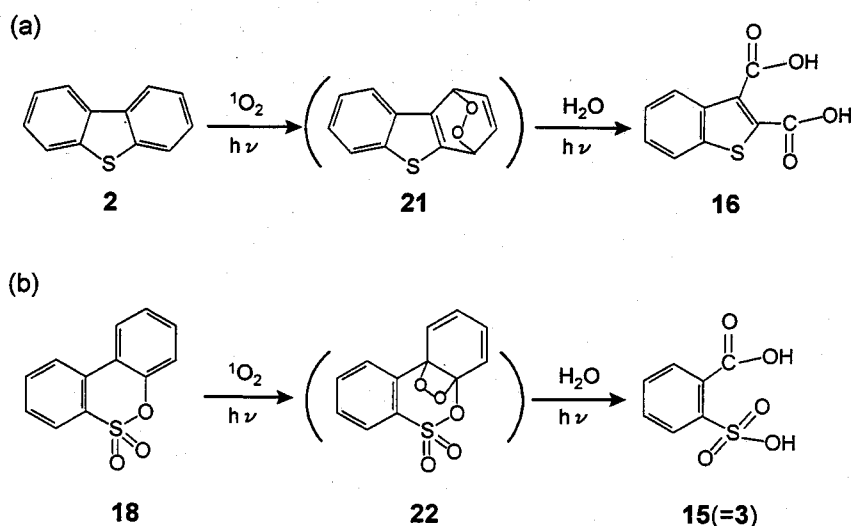

was therefore examined. The results are summarized in **Table 3-3**, and it is significant that both a large conversion of **2** and a high yield of **16** were obtained only in the presence of **19**. The DBT sulfone **19** can be photoexcited by irradiation at $\lambda > 280$ nm, has a high triplet energy of 268 kJ/mol (in EPA glass) (Jenks et al., 1994a), which is a sufficient value for the excitation of O_2 (since the lowest excitation energy of O_2 is 96 kJ/mol), and is photochemically stable in acetonitrile (Jenks et al., 1994b). In addition, 1O_2 is an electrophilic oxidant, and thus the electrophilic addition of 1O_2 on the nucleophilic 4-position may be considered to occur easily. The path from **2** to **16** is thus probably initiated by the adduct of 1O_2 , generated by the photosensitization of **19**, as shown in

Table 3-4. Effect of the Addition of DBT Sulfone 19 on the Conversion of Dibenz[*c,e*][1,2]oxathiin-6,6-dioxide 18 and Yield of 2-Sulfobenzoic Acid 15. ([18]_{initial} = 5 mM, Irradiation Time = 2 h)

addition of 19 (mM)	conversion of 18 (%)	yield of 15 (%)
0	0	0
2.5	12.1	11.7
5	37.2	36.1
10	71.3	68.2

Scheme 3-7a, after which the intermediate **21** is likely to be photolyzed with hydrolysis, and as a result, converted to **16**. The formation of oxygen-adduct intermediates is reported also in the oxidation of anthracene (Foote, 1968; Kearns, 1971). The increase in the concentration of **20** caused by the addition of **19** strongly suggests the generation of $^1\text{O}_2$. The reaction pathway from **18** to **15** appears similarly to involve the $^1\text{O}_2$. The effect of the addition of sulfone **19** on the conversion of **18** and on the yield of **15** is shown in **Table 3-4**. In the case where no **19** was added, the reaction from **18** to **15** hardly progressed, but with increasing concentration of **19**, the increases in both the conversion of **18** and yield of **15** were obtained. The addition of **19** therefore accelerates the reaction from **18** to **15** as well as that from **2** to **16**. Consequently, the reaction from **18** to **15** is likely to involve the unstable intermediate **22**, as shown in **Scheme 3-7b**.

2.4. Photoproducts and Reaction Pathways for 4-Methyl and 4,6-Dimethyl DBT

4-Methyl DBT **23** and 4,6-dimethyl DBT **24** are reported to be the most difficult to desulfurize in the process for hydrodesulfurization (HDS) of light oils (Houalla et al., 1980; Kabe et al., 1992), and therefore their photoproducts and reaction pathways were also studied. The above compounds are photodecomposed more rapidly by the photoirradiation in acetonitrile than nonsubstituted DBT. **Figure 3-25a** shows the gas chromatogram for the acetonitrile solution, initially containing 27 mM 4-methyl DBT **23**, following 10 h photoirradiation. The photoirradiation gave rise to a large number of peaks, but finally four major peaks, **25** (9.3 min), **26** (10.1 min), **27** (13.6 min), and **28** (16.2 min) remained. The mass spectra for these peaks showed molecular ions at m/z 184, 198, 218, and 230 and were thus identified as 2-sulfobenzoic acid **25** (=3), the

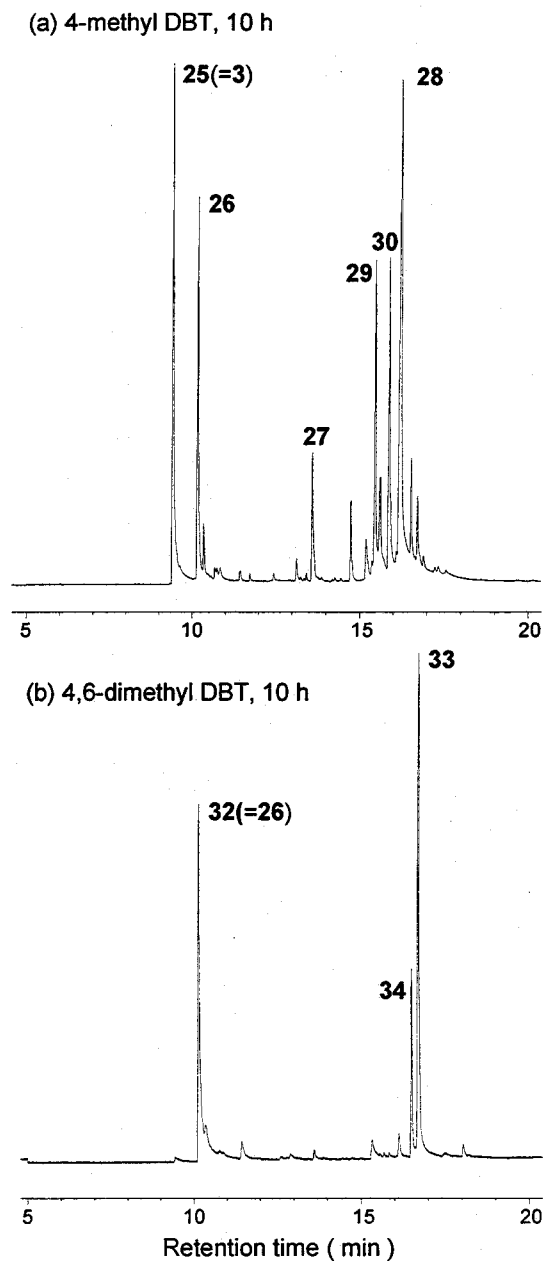
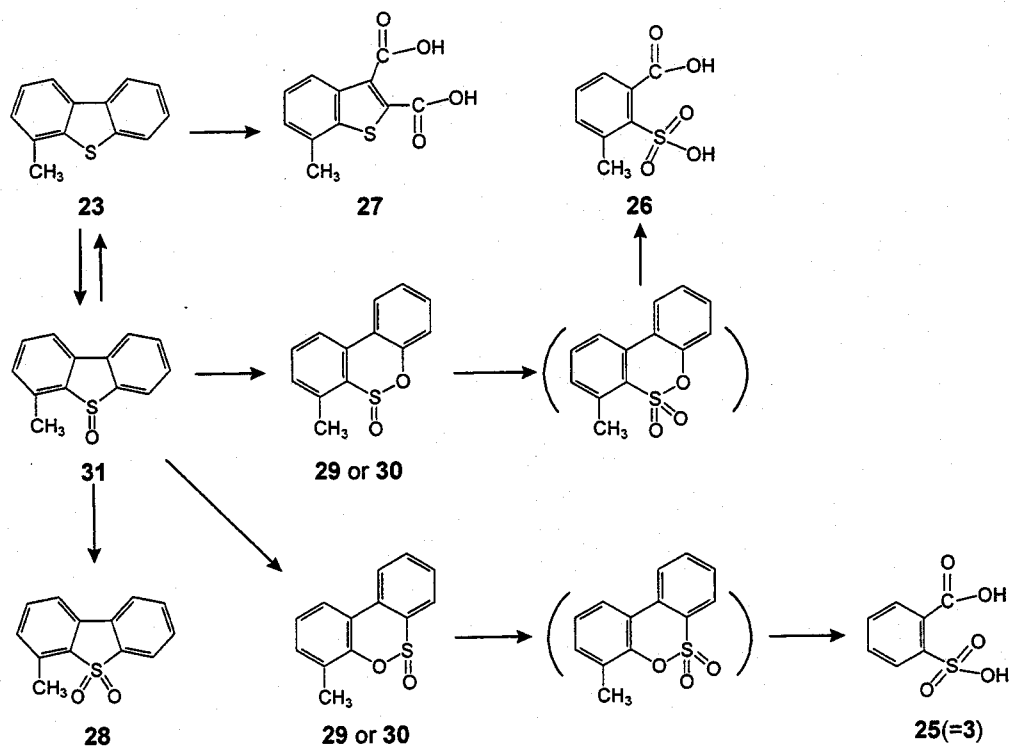

Figure 3-25. GC-AED chromatograms (sulfur, 181 nm) for acetonitrile solution, containing initially 27 mM of (a) 4-methyl DBT **23** and (b) 4,6-dimethyl DBT **24**, following 10 h photoirradiation.

anhydride of 3-methyl-2-sulfobenzoic acid **26**, the anhydride of 7-methylbenzothiophene-2,3-dicarboxylic acid **27**, and 4-methyl DBT sulfone **28**, respectively. After 30 h photoirradiation, the compounds were obtained with the following relative yields: **25**, 26%; **26**, 19%; **27**, 7%, and **28**, 34%. During photoirradiation, peaks for **29** (m/z 230 (M^+)) and **30** (m/z 230 (M^+)) also appeared. These peaks are attributable to either 3-methyldibenz[*c,e*][1,2]oxathiin-6-oxide or 7-methyldibenz[*c,e*][1,2]oxathiin-6-oxide, and therefore two types of sulfobenzoic acid, **25**, and **26** are likely to be formed, according to

Scheme 3-8. Reaction Pathways for 4-Methyl DBT 23 in Acetonitrile by Photoirradiation



the photodecomposition of **29** or **30**. However, the presence of nonsubstituted benzothiophene-2,3-dicarboxylic acid was not observed. The methyl substitution decreases the nucleophilicity on the 4-position of DBT, and thus the 1,4-adduct of $^1\text{O}_2$ is likely to be prevented. The reaction pathway for 4-methyl BT **23** therefore is described, as shown in **Scheme 3-8**. 4-Methyl DBT sulfoxide **31** was detected by HPLC analysis, and therefore, two kinds of sulfobenzoic acid, **25** and **26**, and sulfone **28** seem to form via sulfoxide **31**, as in the case of nonsubstituted DBT.

Photoirradiation of the acetonitrile solution, containing 4,6-dimethyl DBT **24**, gave three main peaks, shown in **Figure 3-25b**, with finally two peaks of **32** (10.1 min) and **33** (16.7 min) remaining, following 30 h photoirradiation. These were identified as 3-methyl-2-sulfobenzoic acid anhydride **32** (=26) and 4,6-dimethyl DBT sulfone **33** from their molecular ions at m/z 198 and 244. The yields were 59% for **32** and 38% for **33**, respectively. Benzothiophene-2,3-dicarboxylic acid was not formed. This seems to be due to methyl substitution on the 4,6-position of DBT. 4,6-Dimethyl DBT sulfoxide **35** and 3,7-dimethyldibenz[*c,e*][1,2]oxathiin-6-oxide **34** were also detected by HPLC

Scheme 3-9. Reaction Pathways for 4,6-Dimethyl DBT 24 in Acetonitrile by Photoirradiation

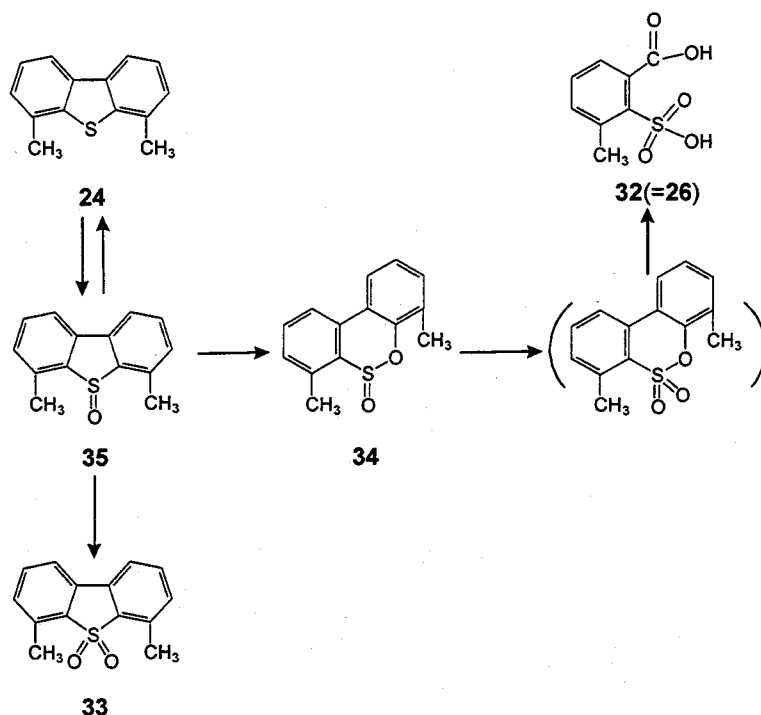

analysis, and therefore the sulfobenzoic acid 32 seems to form via 34 and 35, as shown in Scheme 3-9, as also in the case of DBT and 4-methyl DBT.

Summary

Desulfurization process for light oils, effected by a combination of UV irradiation and liquid-liquid extraction, using an organic two-phase extraction system, has been investigated, and the following results obtained.

1) Photodecomposition of DBT was found to proceed effectively in acetonitrile as compared with the case in nonpolar solvent. Triplet energy transfer from photoexcited DBT to the ground-state bicyclic aromatic hydrocarbons was much suppressed in acetonitrile. The DBT gave rise to six products, sulfoxide, dibenz[*c,e*][1,2]oxathiin-6-oxide, -6,6-dioxide, sulfone, 2-sulfobenzoic acid, and benzothiophene-2,3-dicarboxylic acid, with the latter three compounds finally being obtained. These compounds are highly polarized and therefore not distributed to the light oil. Alkyl-substituted BTs and DBTs were also found to be photodecomposed rather faster as compared with the case in nonpolar solvent, and the photoproducts were also highly polarized compounds.

2) When the light oil was mixed with acetonitrile and photoirradiated, sulfur-containing compounds were distributed from light oil to acetonitrile, and these were photodecomposed there effectively, thus providing the successive removal of sulfur compounds from light oil to acetonitrile. Thus in this way, desulfurization of light oils was much enhanced, in that the sulfur content of commercial light oil was decreased successfully from 0.2 wt% to 0.05 wt% by 2 h photoirradiation and to less than 0.005 wt% by 10 h photoirradiation. Although the desulfurization of aromatic rich light cycle oil was significantly difficult, the sulfur content was decreased successfully to less than 0.05 wt% by increasing acetonitrile/light oil volume ratio.

(3) The coextracted sulfur-free aromatic hydrocarbons into the acetonitrile phase were easily recovered by extraction using light paraffinic hydrocarbons such as *n*-hexane, leaving highly polarized photodecomposed sulfur-containing compounds in the acetonitrile. This separation was performed with greater ease by the addition of 10–20% water into the acetonitrile. The acetonitrile used were recovered by distillation as azeotropic mixture (acetonitrile/water, 84/16 wt%/wt%, 349 K), and were reused for further desulfurization. The overall desulfurization processes for light oils was proposed, in which all the solvents and water can be recirculated.

Chapter IV
Desulfurization of Light Oils
by Visible Light-Induced Electron-Transfer Oxidation
in an Organic Two-Phase Extraction System

Introduction

In the previous Chapter III, a desulfurization process for light oils, based on UV irradiation and liquid-liquid extraction, has been investigated, using an oil/acetonitrile two-phase system. In this process, UV irradiation was, however, essential for direct photodecomposition of the sulfur-containing compounds, and the desulfurization hardly progressed at longer wavelengths region of light. Photodecomposition of aromatic hydrocarbons inevitably occurred simultaneously.

In order to develop more energy-efficient desulfurization process and to suppress the photodecomposition of aromatics, visible wavelength light ($\lambda > 400$ nm) should preferably be used as the light source. Electron-transfer photosensitizers, such as cyano-substituted anthracene, differ from the usual energy-transfer type photosensitizers, which were used in Chapters I and II, and act as the anode by absorbing the wavelength of light equivalent to their lowest excitation energy (Chanon and Ebersson, 1988; Eriksen et al., 1977). Sulfur-containing compounds, having lone electron pairs on the sulfur atom, are expected to be readily one-electron oxidized by this type photosensitizer, and to enable the development of the energy-efficient desulfurization process effected by visible light irradiation.

In this chapter, this new photoprocess has been applied to the indirect photooxidation of BTs and DBTs and to the deep desulfurization of light oils as an extensive study of the previous desulfurization process, as described in Chapter III. The detailed studies on the photooxidation of sulfur compounds, spiked with photosensitizer, are carried out. The photoproducts are compared with those obtained in the direct photodecomposition. Sequential processes, required for the separation and recovery of photosensitizer from the desulfurized light oil and acetonitrile solution, are also studied. Overall desulfurization process is fully organized.

Table 4-1. The Properties and Composition of the Light Oils

		CLO		LGO
		feed	after desulfurization	feed
density (288 K)	(g/mL)	0.8313	0.8056	0.8548
hydrogen	(wt%)	15.8	14.8	12.7
carbon	(wt%)	83.2	86.1	85.2
sulfur	(wt%)	0.179	0.020	1.380
saturated fraction	(vol%)	77.9	84.6	75.4
aromatics ^a	(vol%)			
monocyclic		17.5	14.5	14.9
bicyclic		4.6	0.9	9.7
distillation	(K)			
IBP		447	470	484
10 vol%		486	504	533
20 vol%		509	525	547
30 vol%		527	542	558
50 vol%		554	567	574
70 vol%		580	589	594
80 vol%		595	602	605
90 vol%		614	620	621
FBP		641	645	644

^a Tricyclic and higher polycyclic aromatics were present in trace quantities (<1%)

Experimental Section

1. Materials

In addition to the materials used in previous chapters, 9,10-dicyanoanthracene (DCA) and other photosensitizers were purchased from Tokyo Kasei Co., Ltd. Commercial light oil (CLO) and straight-run light gas oil (LGO) were used as feedstocks. The relevant properties of these light oils are summarized in **Table 4-1**. Silica gel (average diameter: 90 μm), aluminum oxide (171 μm), and zeolite 13 X (74 μm) were used in the studies of the adsorption of DCA from light oil, following activation treatment.

2. Apparatus and Procedure

The CLO or LGO was mixed vigorously with acetonitrile solution, using a magnetic stirrer, at volume ratio varying from 50/350 to 200/200 mL/mL with the total solution

volumes of 400 mL. The required amount of photosensitizer was added to the solutions, and these were then photoirradiated by the immersion of a high-pressure mercury lamp (300 W, Eikohsha Co., Ltd., Osaka), combined with air bubbling (500 mL/min), as shown in **Figure 1-1**. The homogeneous acetonitrile solutions (400 mL), in which the starting sulfur-containing compounds and photosensitizer are dissolved, were also employed for the photoreaction studies. A uranyl glass filter and a 3 wt% NaNO₂ aqueous solution filter were used to give light wavelength rejections of shorter than 320 and 400 nm, respectively (Carbart and Pitts, 1966). The extraction and adsorption experiments were conducted at 298 ± 1 K, and were carried out in a shake flask or a glass column (10 mm i. d. × 500 mm).

3. Analysis

The fluorescence spectra were measured using a fluorescence spectrophotometer (JASCO Corporation FP-777) at 298 K with excitation wavelength at 350 nm and with detection wavelength at 440 nm; this being done after nitrogen had been bubbled through the solutions for 5 min. Fluorescence quenching rate constants were obtained by analysis of a Stern-Volmer plot (Rehm and Weller, 1970). The concentrations of the starting materials, products, and photosensitizer in the polar solvents were analyzed by reverse-phase HPLC (Shimadzu LC-6A, equipped with a spectrophotometric detector SPD-6A) at 241 and 261 nm, respectively. The concentration of photosensitizer in the hydrocarbon solution was analyzed by normal-phase HPLC equipped with fluorescence detector (Shimadzu RF-550), with the excitation wavelength at 350 nm and a detection wavelength at 440 nm. The water content of the solutions was determined by Karl-Fisher titration (Kyoto Electronics MKS-1).

Results and Discussion

1. Photoinduced Electron-Transfer Oxidation of Sulfur Compounds

1.1. Photooxidation of Dibenzothiophene

Electron-transfer photosensitizer, such as 9,10-dicyanoanthracene (DCA), is photoexcited by the light wavelength equivalent to the lowest excitation energy. The fluorescence of the photosensitizer is quenched by certain electron-rich substrates, and the

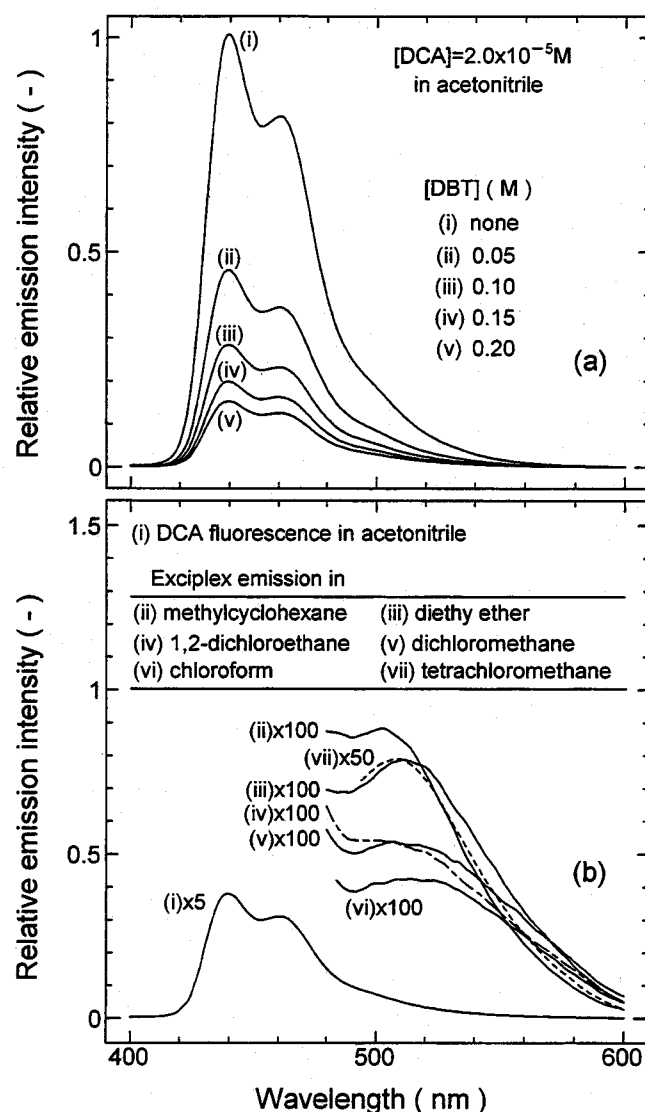

Figure 4-1. Fluorescence Spectra for DCA in the presence of various quantity of DBT in (a) acetonitrile and (b) nonpolar solvents.

electron on the substrates transferred to the photosensitizer. **Figure 4-1a** shows the fluorescence spectra for DCA in acetonitrile in the presence of various quantity of DBT. The blue fluorescence of DCA was quenched by DBT, and yellow fluorescence then exhibited. The fluorescence intensity of DCA was decreased monotonously with increasing quantity of DBT added, with a diffusion controlled rate of $k_{q, DBT} = 1.75 \times 10^{10} L mol^{-1} s^{-1}$. The DCA has a relatively low reduction potential (1.97 eV) (Eriksen and Foote, 1978), which is lower than oxidation potential for DBT (1.20 eV) (Bontempelli et al., 1973). From these data, the free energy changes (ΔG) for the one-electron transfer process from the DBT to the excited singlet DCA ($^1DCA^*$) were estimated by the application of the Rehm–Weller equation (Rehm and Weller, 1970), as below:

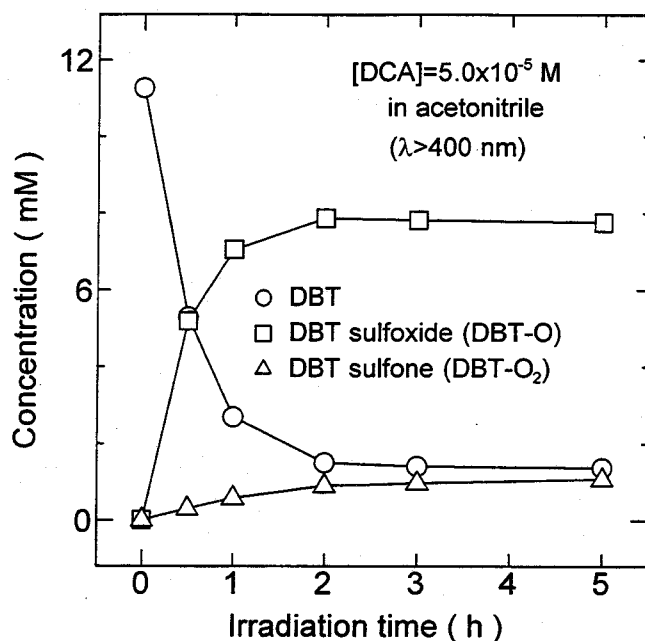

Figure 4-2. Time-course variation in the concentrations of DBT, DBT-O, and DBT-O₂ in acetonitrile in the presence of DCA (5.0×10^{-5} M) during photoirradiation ($\lambda > 400$ nm).

$$\Delta G = 96.4 [E(D/D^+) - E(A^-/A) - e^2/a\epsilon - E_{0,0}] \quad (\text{kJ/mol}) \quad (4-1)$$

where $E(D/D^+)$ and $E(A^-/A)$ are the oxidation potential of DBT and the reduction potential of DCA, respectively, and $e^2/a\epsilon$ and $E_{0,0}$ are the energy of Coulomb force and the excited singlet energy of DCA, respectively. Negative ΔG value (-62.2 kJ/mol) was obtained for DBT, thus suggesting that the electron-transfer from DBT to photoexcited DCA occurs exothermically. As shown in **Figure 4-1b**, exciplex $[\text{DCA} \cdots \text{DBT}]^*$ emission was observed, at longer wavelength region than residual DCA fluorescence in nonpolar solvents and not in polar solvents such as acetonitrile and alcohol, thus suggesting that dissociation of the exciplex into the separated radical ions, $[\text{DCA}]^-$ and $[\text{DBT}]^+$, occurs only in the most polar solvents.

An acetonitrile solution containing both DBT and DCA was irradiated to visible light of wavelength $\lambda > 400$ nm. As shown in **Figure 4-2**, in acetonitrile, the corresponding sulfoxide (DBT-O) and sulfone (DBT-O₂) were photogenerated in high yields. The two photoproducts of DBT (DBT-O and DBT-O₂) are both highly polarized and insoluble to nonpolar light oil, as described in Chapter III. Thus, the present photoprocess has potential for the desulfurization of light oil. No reaction was, however, observed in nonpolar solvents, as shown in **Table 4-2**. This behavior is expected for a

Table 4-2. Solvent Effect on the Photooxidation of DBT (irradiation time: 1 h, [DBT]_{initial}=11 mM, [DCA]=2.0×10⁻⁵ M, λ > 320 nm)

solvent	dielectric constant ε (-)	conversion (%)
acetonitrile	37.5	90.2
<i>t</i> -butyronitrile	20.3	29.0
benzonitrile	25.2	21.4
DMSO	48.9	0
sulfolane	44.0	0
DMF	36.7	6.16
dichloromethane	7.77	0
benzene	2.27	0
methanol	32.63	0
2-propanol	18.3	0
tetradecane		4.05
decalin		0

process proceeding via an intermediate ion pair, since such exciplex will be too poorly solvated in nonpolar solvents, having low dielectric constant, to be separated into the radical ions. As shown in **Table 4-2**, although both DMSO and sulfolane have higher dielectric constants, no conversion of DBT was observed. When DCA was added into these solvents, blue fluorescence diminished and yellow fluorescence was observed in the absence of DBT. These findings suggest that these solvents quench the fluorescence of DCA themselves, such that the fluorescence quenching of DCA by DBT is prevented. These results demonstrate that the acetonitrile was shown to be the most suitable solvent for photooxidation of DBT.

As shown in **Table 4-3**, other photosensitizers such as *p*-benzoquinone and 1-cyanonaphthalene, usually used for photooxidation of organic substrates, are not applicable to this process. This is probably because the oxidation potential of 9-cyanoanthracene is lower than the reduction potential for molecular oxygen, and 1-cyanonaphthalene is required to be photoexcited at shorter wavelength than 320 nm. These findings suggest that DCA is the most suitable photosensitizer for the photooxidation of DBT, which seems to proceed via the three steps shown schematically in **Figure 4-3**. These are (1) photoexcitation of DCA, (2) one-electron oxidation of DBT

Table 4-3. The Electrochemical Properties of Electron-Transfer Photosensitizers and Their Effect on the Conversion of DBT in Acetonitrile (irradiation time: 1h, $\lambda > 320$ nm, $[\text{DBT}]_{\text{initial}} = 11$ mM, $[\text{Sensitizer}] = 2.0 \times 10^{-5}$ M)*

photosensitizer	$\Delta E(^1A^*)$ (eV) ^a	$E_{(D/D^+)}^{\text{ox}}$ (eV)	$E_{(A/A^+)}^{\text{ox}}$ (eV) ^b	$E_{(A/A^-)}^{\text{red}}$ (eV)	conversion (%)
(no addition)					0
9-cyanoanthracene	3.10		-1.70	1.90 ^b	23.0
<i>p</i> -benzoquinone	2.61		-0.51	2.10 ^b	0
1-cyanonaphthalene	3.88		-1.98	1.40 ^b	1.79
9,10-dicyanoanthracene	2.86		-0.89	1.97 ^b	90.2
O ₂				-0.82 ^d	
DBT	3.80	1.20 ^c		-2.432 ^e	

^a Murov et al. (1993); ^b Chanon and Ebersson (1988); ^c Bontempelli et al. (1973); ^d Mattes and Farid (1980); ^e Gerdil and Lucken (1966); *All potentials shown are half-wave potential vs. saturated calomel electrode (SCE).

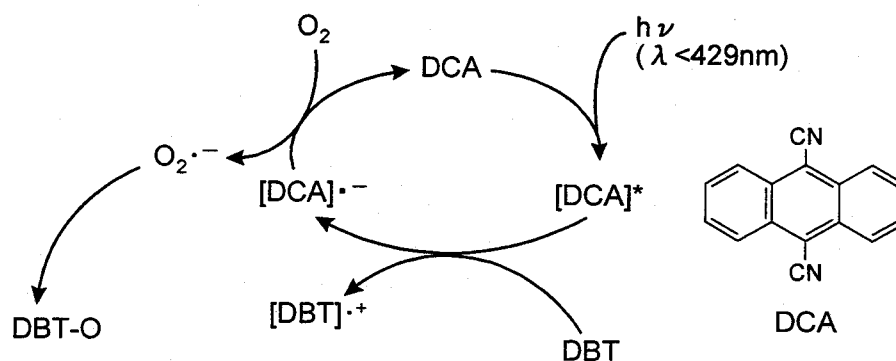

Figure 4-3. Electron-transfer process occurring in acetonitrile between DCA, DBT and molecular oxygen.

and one-electron reduction of O₂ (generation of superoxide ion O₂^{•-}) and (3) combination of radical ion pairs (DBT^{•+} and O₂^{•-}). As shown in **Table 4-2**, the photoconversion yield of DBT in polar alcoholic solvent is significantly lower than that obtained in acetonitrile. This is because the lifetime for O₂^{•-} in alcohol is shorter than that in acetonitrile (Murov et al., 1993). During the photoirradiation of the DCA/acetonitrile solution, no degradation or decrease in the fluorescence intensity of DCA is observed, thus suggesting that the DCA can be recovered and reused for further photooxidation.

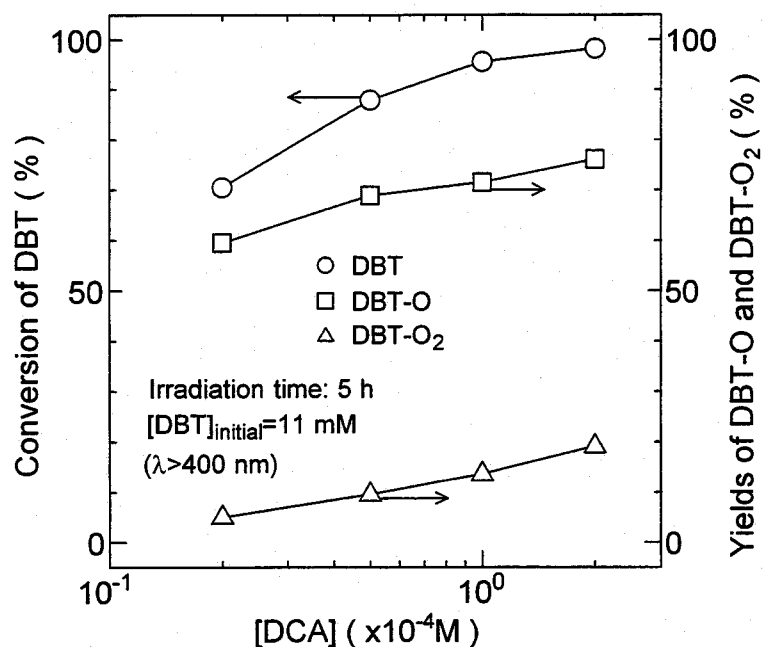

Figure 4-4. Effect of the concentration of DCA on the conversion of DBT and the yields of DBT-O and DBT-O₂ following 5 h photoirradiation ($\lambda > 400 \text{ nm}$).

Table 4-4. Fluorescence Quenching Rate Constants for DCA, k_q , for DBTs, BTs, and Aromatic Hydrocarbons

substrates	k_q ($\times 10^8 \text{ L mol}^{-1} \text{ s}^{-1}$)
DBT	175
DBT-O	73.5
DBT-O ₂	3.43
4-methyl DBT	179
4-methyl DBT-O	>200
4-methyl DBT-O ₂	15.6
4,6-dimethyl DBT	193
4,6-dimethyl DBT-O	>200
4,6-dimethyl DBT-O ₂	37.9
BT	142
3-methyl BT	139
2,3-dimethyl BT	164
tetralin	5.93
naphthalene	160

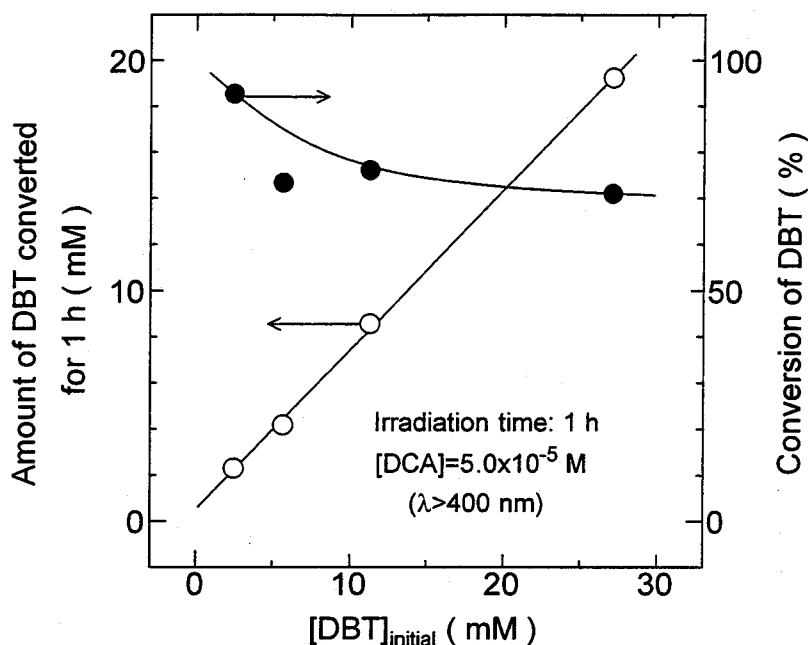

Figure 4-5. Effect of the initial concentration of DBT on the conversion of DBT and the amount of DBT converted during 1 h photoirradiation ($\lambda > 400$ nm). The concentration of DCA is 5.0×10^{-5} M.

As shown in **Figure 4-4**, for low DCA concentration (5×10^{-5} M), the reaction rate for DBT is very large over the time period 0–1 h. But the rate then decreases with the reaction becoming almost saturated for times greater than 2 h. As shown in **Table 4-4**, the fluorescence quenching rate constant, k_q for DBT-O, is relatively large, such that the fluorescence of the DCA is quenched competitively by the DBT-O formed, resulting in a suppression of the photooxidation of the DBT. However, as shown in **Figure 4-4**, increasing the DCA concentration up to 2.0×10^{-4} M results in the DBT being completely oxidized. This is because the larger quantity of DCA enhances the contact with DBT, such that the competitive fluorescence quenching by the DBT-O is reduced.

Figure 4-5 shows the effect of the initial concentration of DBT both on the percentage conversion of DBT and on the amount of DBT converted during 1 h photoirradiation. Although the conversion of DBT decreases slightly with increasing initial concentration of DBT, the amount of DBT converted by 1 h-irradiation increases linearly. These results suggest that the higher the concentration of sulfur-containing compound and the higher the DCA concentration, the greater is the quantity of the sulfur-containing compound oxidized.

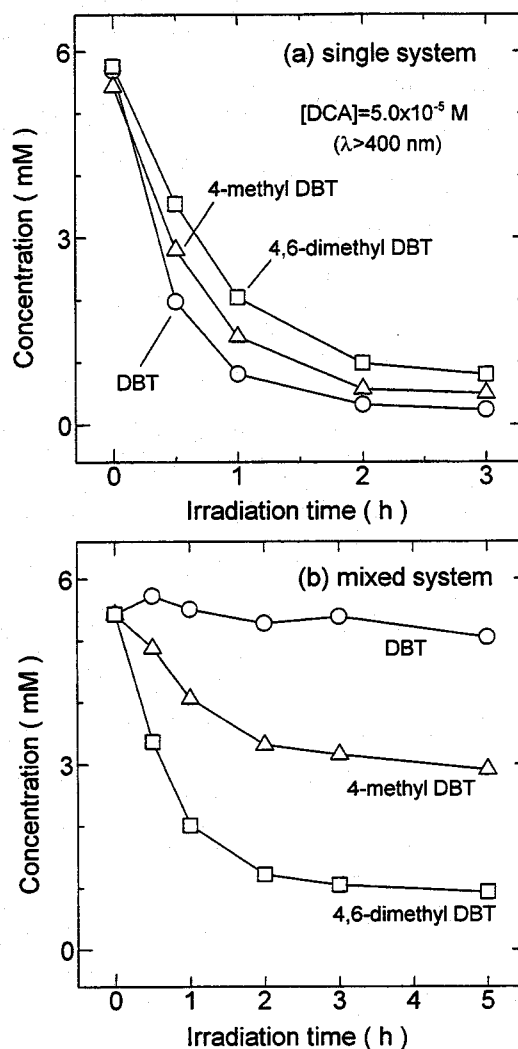

Figure 4-6. Time-course variation in the concentrations of DBT, 4-methyl DBT, and 4,6-dimethyl DBT during photoirradiation ($\lambda > 400$ nm) for a (a) single-component system and (b) mixed component system.

1.2. Photooxidation of Methyl-Substituted DBTs

The photoreactivity of 4-methyl DBT and 4,6-dimethyl DBT was also studied, since these compounds are the most difficult to desulfurize using the hydrodesulfurization (HDS) method (Kabe et al., 1992; Houalla et al., 1980). As shown in **Table 4-4**, the fluorescence quenching rate constants, k_q , for these compounds are slightly larger than that for nonsubstituted DBT, with a ranking order of 4,6-dimethyl DBT > 4-methyl DBT > DBT, thus indicating that electron-transfer from the methyl-substituted DBTs to DCA occurs more easily. Photoirradiation to acetonitrile solutions, containing 4-methyl DBT or 4,6-dimethyl DBT, also produced only the corresponding sulfoxides and sulfones. For the single component system, the reaction rates for the methyl-substituted DBTs were,

however, lower than that for the nonsubstituted DBT, as shown in **Figure 4-6a**, with the rate ranking order being DBT > 4-methyl DBT > 4,6-dimethyl DBT.

To clarify the reason for this observation, the fluorescence quenching rate constants of the corresponding sulfoxide and sulfone compounds were measured. As shown in **Table 4-4**, the k_q values for these compounds increase according to the substituents. The values especially for 4-methyl DBT-O and 4,6-dimethyl DBT-O are much larger than that for nonsubstituted DBT-O. These substituted sulfoxides therefore prevent more strongly the fluorescence quenching of the DCA by DBTs than that by nonsubstituted DBT-O, and as a result, the photooxidation of 4-methyl DBT and 4,6-dimethyl DBT are significantly suppressed. As shown in **Figure 4-6b**, when DBT, 4-methyl DBT and 4,6-dimethyl DBT were mixed in acetonitrile for photoirradiation, the photooxidation of the methyl-substituted DBTs proceeded more rapidly than the reaction of nonsubstituted DBT, in the order 4,6-dimethyl DBT > 4-methyl DBT > DBT. Thus, the refractory methyl-substituted DBTs, as found in the HDS process, are oxidized to a predominantly greater extent than the nonsubstituted DBT, when employing the photosensitized oxidation spiked with DCA. This is the same tendency as those obtained for direct photooxidation using UV light in Chapter I, II, and III.

1.3. Photooxidation of Benzothiophenes

Benzothiophenes (BTs) are main constituents of the sulfur-containing compounds in light oils. The photooxidation of BTs using DCA was, therefore, also studied. **Figure 4-7** shows the time-course variation in the concentrations of BT and photoproducts during photoirradiation. The decrease in BT and the formation of benzothiophene-2,3-dione and 2-sulfobenzoic acid were found to occur quantitatively. The former compound was formed in the larger proportion, whereas UV irradiation produced the latter compound more predominantly, as described in Chapter III. Since the fluorescence quenching rate for BT is less than that for DBT (**Table 4-4**), this causes the decrease in the concentration of BT to be slower. In the electrochemical oxidation of BT in methanol under nitrogen atmosphere, 2,3-dimethoxylated BT was reported to be the major product (Srogl et al., 1978). In the photosensitized oxidation of BT, when spiked with DCA, the electron on the unsaturated 2- and/or 3-position not on the sulfur atom is initially withdrawn by the DCA to produce predominantly benzothiophene-2,3-dione.

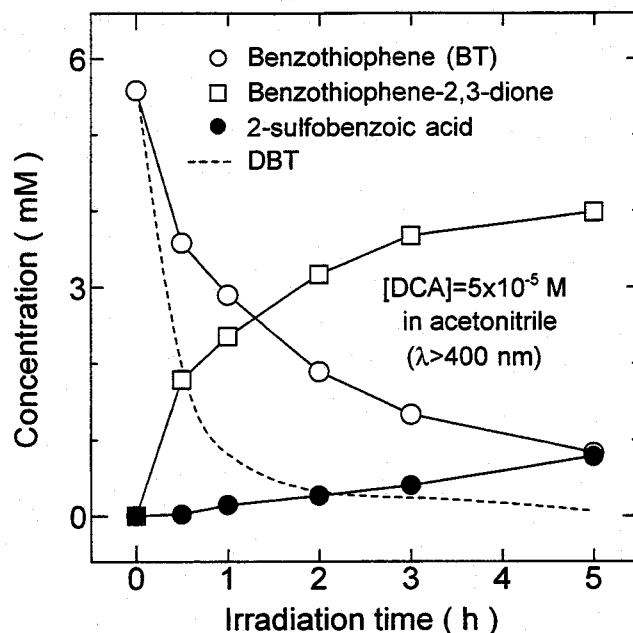

Figure 4-7. Time-course variation in the concentrations of BT and photoproducts during photoirradiation ($\lambda > 400$ nm) in the presence of DCA (5.0×10^{-5} M).

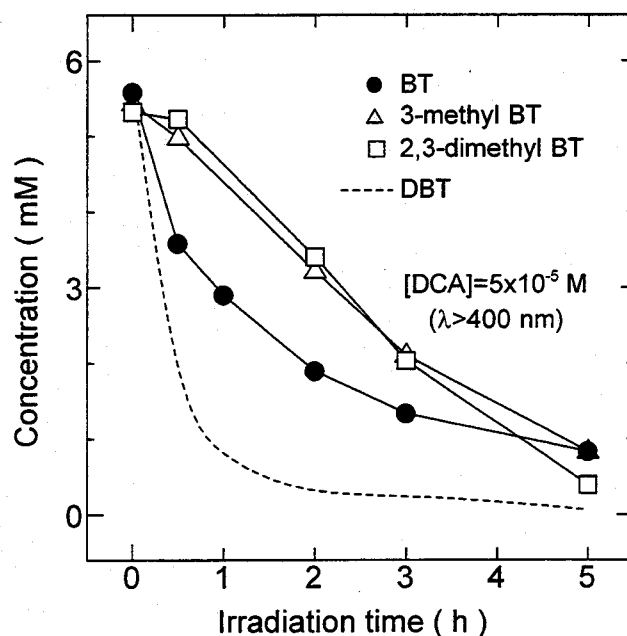

Figure 4-8. Time-course variation in the concentration of BT, 3-methyl BT and 2,3-dimethyl BT in a single-component system, during photoirradiation ($\lambda > 400$ nm) in the presence of DCA (5.0×10^{-5} M).

Figure 4-8 shows the comparison in the reaction rates for methyl-substituted BTs, such as 3-methyl BT and 2,3-dimethyl BT, in acetonitrile. Although as shown in **Table 4-4**, the fluorescence quenching rates for methyl-substituted BTs show nearly the same values as nonsubstituted BT, decrease in the concentration at 0–2 h for methyl-substituted

BTs was slower, thus indicating that the methyl substituents prevent the oxidation in the 2- and 3-positions. Methyl substituents on the 2- and/or 3-positions have been reported to inhibit the electrooxidation of BTs (Srogl et al., 1978). However, following 5 h photoirradiation, almost the same conversion was attained for BT and for the methyl-substituted BTs. Thus in the photosensitized oxidation, when spiked with DCA, the methyl-substituted BTs on the 2- and/or 3-positions can also be oxidized satisfactorily. By GC-MS analyses, it was found that, following 10 h photoirradiation, 3-methyl BT gives benzothiophene-3-carbaldehyde (69%) and benzothiophene-3-carboxylic acid (14%) as main products. 2,3-Dimethyl BT gives 2-methylbenzothiophene-3-carbaldehyde (54%), 3-methylbenzothiophene-2-carbaldehyde (14%), benzothiophene-2,3-dicarbaldehyde (6%) and benzothiophene-2,3-dicarboxylic acid (2%). Most of these photoproducts are the same as those produced by photooxidation using UV light, as described in Chapter III. The compounds were eluted at earlier retention times on reverse-phase HPLC analysis than those for the corresponding BTs, thus suggesting that they are highly polarized compounds, which do not distribute into nonpolar light oil, as found in the case of the DBTs.

1.4. Effect of the Aromatic Hydrocarbons on the Photooxidation of DBT

As shown in Table 4-1, one- and bicyclic aromatic hydrocarbons are main constituents of light oils. When the commercial light oil is contacted with acetonitrile at the volume ratio of 1:1, 17% of the monocyclic and 27% of the bicyclic aromatics are distributed into the acetonitrile phase together with the sulfur-containing compounds. This means that the acetonitrile at equilibrium contains about 140 mM of tetralin and 80 mM of naphthalene. Tetralin and naphthalene were used therefore as models, and were added to the acetonitrile together with the DBT, and then photoirradiated for 1h in the presence of DCA. A 11 mM feed concentration of DBT was employed, corresponding to a sulfur content of 0.05 wt%. The results are summarized in Table 4-5, in which a selectivity for the conversion of DBT, α , is defined as:

$$\alpha = \frac{[\text{conversion of DBT}]}{[\text{conversion of DBT}] + [\text{conversion of naphthalene}] + [\text{conversion of tetralin}]} \quad (4-2)$$

Table 4-5. Effect of the Addition of Aromatic Hydrocarbons on the Conversion of DBT and Selectivity of Conversion of DBT, α (Irradiation Time, 1 h; $[\text{DBT}]_{\text{initial}} = 11 \text{ mM}$; $[\text{DCA}] = 2.0 \times 10^{-5} \text{ M}$; $\lambda > 320 \text{ nm}$)

run	naphthalene (mM)	tetralin (mM)	conversion of naphthalene (%)	conversion of tetralin (%)	conversion of DBT (%)	selectivity α (-)
1	–	–	–	–	58.8	1
2	55	–	6.80	–	51.4	0.883
3	110	–	6.55	–	34.2	0.839
4	–	55	–	6.73	53.3	0.888
5	–	110	–	3.62	49.3	0.932
6	55	55	5.54	4.94	50.0	0.828
7	110	110	4.44	5.79	37.3	0.785
8 ^a	–	–	–	–	59.2	1
9 ^a	40	–	13.2	–	17.9	0.575
10 ^a	80	–	7.23	–	12.8	0.639

^aRuns 8–10 are data obtained by UV irradiation without DCA (Chapter III).

When a 10-fold quantity of naphthalene or tetralin compared to DBT was added (runs 3 and 5), the conversion of DBT was decreased from 58.8 to 34.2 and 49.3% respectively, since these aromatics also quench the fluorescence of DCA, as shown in **Table 4-4**. Naphthalene quenches the fluorescence of DCA more strongly than tetralin, and therefore the photooxidation of DBT is suppressed more strongly by the naphthalene. The values for the α , the selectivity for the conversion of DBT, however, still remain greater than 0.78 even in the presence of 10-fold quantities of naphthalene and tetralin (run 7). This is because the electron on the sulfur-atom of DBT is localized (Bonchio et al., 1995), and thus the electron on the DBT is predominantly withdrawn by DCA.

Runs 8–10 show the results obtained for experiments in which UV light was irradiated without DCA being present. Without naphthalene or tetralin present (run 8), the conversion of DBT was almost the same as that obtained in run 1. However, with naphthalene present, the conversion decreased significantly to less than 18%, and the selectivity for the conversion of DBT also decreased to less than 0.64. This is because the triplet-energy transfer from the photoexcited DBT to the ground-state

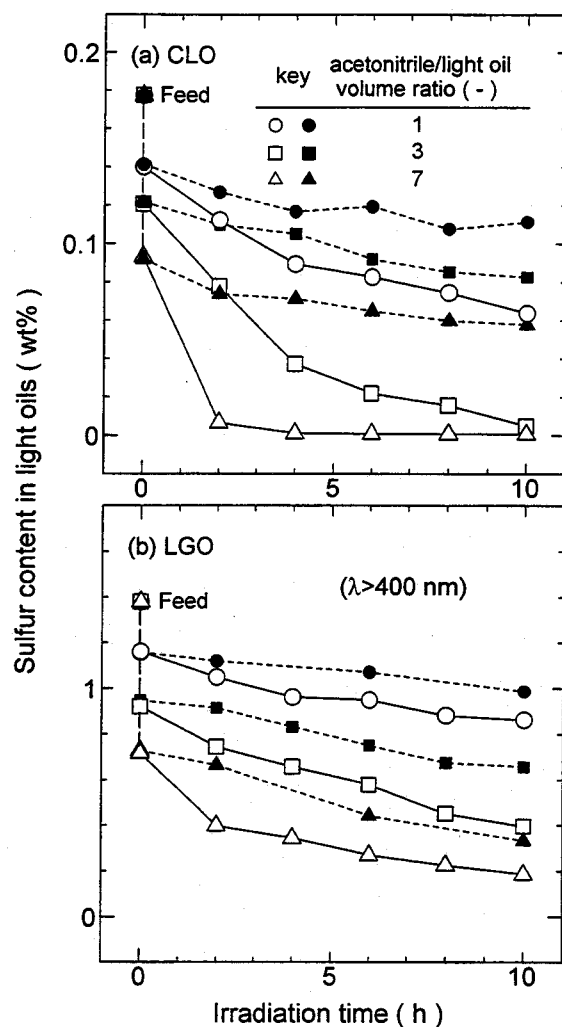

Figure 4-9. Time-course variation in the sulfur contents in (a) commercial light oil (CLO) and (b) straight-run light gas oil (LGO), using the light oil/acetonitrile two-phase system, when combined with photoirradiation ($\lambda > 400$ nm) both in the presence and absence of DCA. Closed key, without DCA; open key, with DCA.

naphthalene occurs, resulting in the photodecomposition of the naphthalene, as described in Chapter III. The photooxidation of DBT using DCA, therefore, proceeds effectively even in the presence of aromatic hydrocarbons.

2. Desulfurization of Light Oils by Electron-Transfer Photooxidation

2.1. Effect of DCA on the Desulfurization of Light Oils

The effect of the DCA on the desulfurization of actual light oils, such as commercial light oil (CLO) and straight-run light gas oil (LGO), was studied using acetonitrile as solvent. A saturated quantity of DCA was dissolved in the light oils ($[DCA]_{CLO} =$

Table 4-6. Quantities of BTs and DBTs, Having Different Carbon Number Substituent, in Commercial Light Oil (CLO) and Straight-Run Light Gas Oil (LGO) Following the Extraction (Acetonitrile and Light oil Volume Ratio = 3) and 10 h Photoirradiation with DCA ^a

species	CLO			LGO		
	(i) (wt%)	(ii) (wt%)	(iii) (wt%)	(i) (wt%)	(ii) (wt%)	(iii) (wt%)
<C1-BT ^b	0.00721	0.00338	0	0.02424	0.01226	0
C2-BT	0.00464	0.00207	0	0.03230	0.01427	0.00385
C3-BT	0.00965	0.00567	0	0.11545	0.05758	0.01294
C4-BT	0.01022	0.00731	0	0.13036	0.07291	0.01725
C5-BT	0.00405	0.00202	0	0.08182	0.05030	0.01317
C6-BT	0.00895	0.00742	0.00013	0.12463	0.08193	0.02027
C7-BT	0.00126	0.00100	0.00014	0.01637	0.01120	0.00352
C8-BT	0.00298	0.00272	0.00024	0.03838	0.02818	0.00805
BTs (total)	0.04896	0.03159	0.00051	0.56355	0.32863	0.07905
DBT	0.00301	0.00154	0.00009	0.03258	0.01889	0.00070
C1-DBT	0.01475	0.00637	0.00014	0.09325	0.05582	0.02245
C2-DBT	0.01840	0.01241	0.00024	0.14333	0.09261	0.04242
C3-DBT	0.01777	0.01446	0.00031	0.14400	0.10345	0.04748
C4-DBT	0.01223	0.00916	0.00021	0.09050	0.06757	0.03147
C5-DBT	0.00361	0.00283	0.00009	0.02664	0.02068	0.01000
C6-DBT	0.06058	0.04076	0.00339	0.28614	0.23265	0.15544
DBTs (total)	0.13035	0.08753	0.00447	0.81644	0.59167	0.30996
Total sulfur	0.17931	0.11912	0.00498	1.37999	0.92030	0.38901

^a (i) Feed; (ii) after contact with acetonitrile (simple extraction); (iii) after 10 h photoirradiation.

^b < C1-BT contains also nonsubstituted BT and alkyl and arylsulfides.

1.8×10^{-4} M, $[DCA]_{LGO} = 1.9 \times 10^{-4}$ M), with acetonitrile ($[DCA]_{acetonitrile} = 3.9 \times 10^{-4}$ M), being mixed and photoirradiated at various solution volume ratios. The time-course variation in the sulfur content of the CLO is shown in **Figure 4-9a**. The data points for an irradiation time of zero are those obtained simply by mixing the two phases and indicate the equilibrium distribution concentrations for the sulfur contents of the two phases. The distribution in the sulfur-containing compounds was found not to be affected by the presence of DCA. Without DCA, the decrease in the sulfur content was

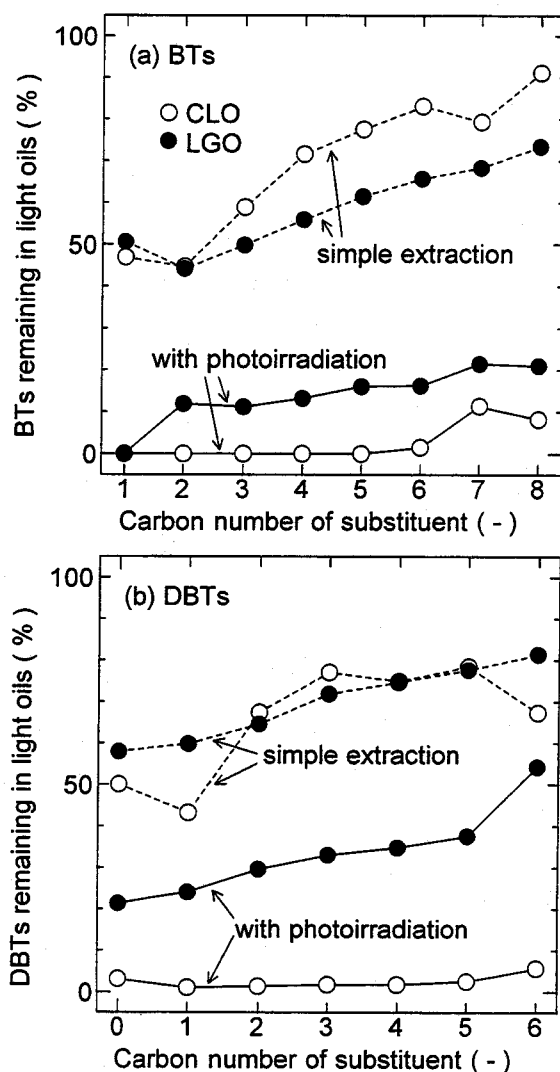

Figure 4-10. Remaining percentage of (a) benzothiophenes (BTs) and (b) dibenzothiophenes (DBTs) in CLO and LGO after simple extraction and 10 h photoirradiation in the presence of DCA, with respect to the carbon number of the alkyl substituents. Acetonitrile and light oils volume ratio = 3. The initial amount of each alkyl-substituted BTs and DBTs in light oils is set as 100%.

very small, as expected. With DCA, the sulfur content was decreased considerably with irradiation time. For example, at a volume ratio of 3, the sulfur content was decreased from 0.18 to 0.04 wt% by 4 h photoirradiation and to less than 0.005 wt% by 10 h photoirradiation. This sulfur content of 0.005 wt% accords with the value, now strictly regulated by Sweden and Switzerland, thus therefore indicates that the present photoprocess is effective for the deep desulfurization of light oils. As shown in **Figure 4-9b**, the desulfurization of LGO was also enhanced by the addition of DCA. At the volume ratio of 7, the sulfur content in LGO was decreased, for example, from 1.38 wt%

to 0.2 wt%, following 10 h photoirradiation. At this volume ratio, the quantities of sulfur removed from CLO and LGO following 10 h photoirradiation were about 0.09 wt% and 0.5 wt%, respectively, thus representing a 5-fold reduction in the quantity of sulfur in LGO as compared to that of CLO. The relatively long irradiation time required in these studies may be expected to be reduced considerably for industrial purpose via the development of a photoreactor of appropriate advanced design.

Variations in the composition of the sulfur-containing compounds in CLO and LGO following extraction and 10 h photoirradiation (acetonitrile and light oils volume ratio = 3/1) are shown in **Table 4-6**, and the data are plotted in **Figure 4-10** as a function of the carbon number of the alkyl substituent. In both CLO and LGO, the remaining portion for BTs and DBTs has a tendency to increase with an increase in the carbon number of the alkyl substituents. This occurs since the distribution into the acetonitrile phase is reduced with the carbon number of alkyl substituents. With photoirradiation, 99% of the BTs and 97% of the DBTs in CLO, and 86% of the BTs and 62% of the DBTs in LGO were removed, and a higher removal for the BTs was attained than for the DBTs. This is because that the BTs have a higher tendency to distribute to acetonitrile owing to their greater polarity.

Values for the sulfur distribution ratio, D_s , defined as the ratio of the total sulfur content in the acetonitrile and in the light oils, following 2 h photoirradiation, are shown in **Figure 4-11**. For CLO, the value of D_s is increased with increasing the acetonitrile volume ratio. At a volume ratio of 7, a value of D_s up to 1.4 is obtained, which is comparable to that obtained in the previous Chapter III following UV irradiation without DCA. The increase in acetonitrile volume probably decreases the photoscattering and light exclusion by the light oil phase, and thus causes an effective photoexcitation of the DCA. For LGO, however, the value of D_s was hardly changed for visible-light excitation by increase in the acetonitrile volume, and the value obtained was considerably lower than those obtained in CLO and also for the value for LGO using UV irradiation. LGO contains a 2-fold quantity of bicyclic aromatics greater than CLO, as shown in **Table 4-1**, and thus the photooxidation of BTs and DBTs is more likely to be suppressed by competitive fluorescence quenching of the DCA by the distributed aromatic

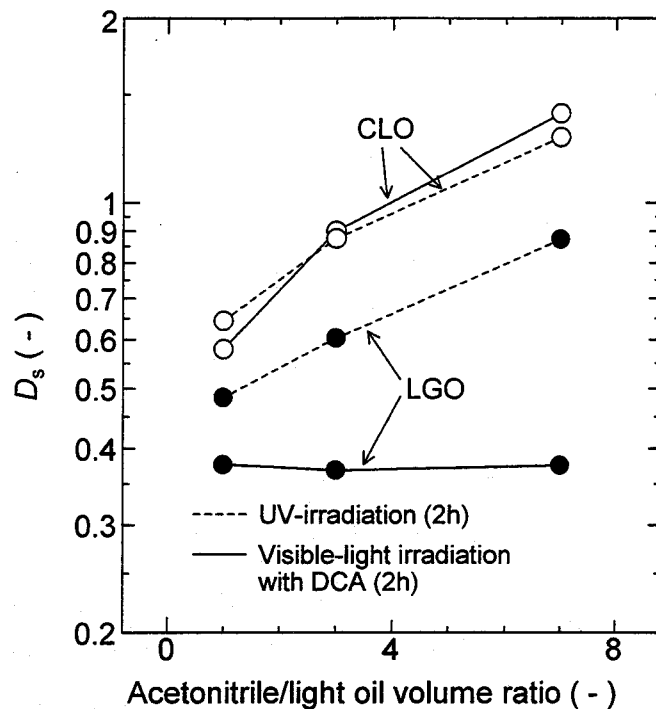

Figure 4-11. Effect of photooxidation reaction using DCA on the sulfur distribution ratio, D_s , in CLO/acetonitrile and LGO/acetonitrile systems. Acetonitrile and light oil volume ratio = 3. D_s is the ratio of the total sulfur content in acetonitrile and in light oils.

hydrocarbons. The present process is therefore not so effective for light oils of high aromatic content.

2.2. Effect of Water on the Desulfurization of Light Oil

When contacting the two phases, a quantity of acetonitrile is dissolved into the light oil. This can be recovered by washing with water, and is regenerated by distillation as an azeotropic mixture (acetonitrile/water, 84/16 v/v (bp. 350 K)), as described in the previous Chapter III. The effect of water on the photooxidation of DBT in acetonitrile and desulfurization of light oil was therefore investigated. The fluorescence quenching rate constant, k_q for DBT is slightly decreased from $1.81 \times 10^{10} \text{ Lmol}^{-1}\text{s}^{-1}$ at 0% water content to $1.70 \times 10^{10} \text{ Lmol}^{-1}\text{s}^{-1}$ at 20% water content, and therefore the conversion of DBT is also decreased by the presence of water. The effect of the addition of water on the decrease in the sulfur content in CLO obtained is shown in **Figure 4-12**. For water concentrations in the region 10–20%, however, the sulfur content was still found to be decreased effectively to less than 0.05 wt%, following 10 h photoirradiation.

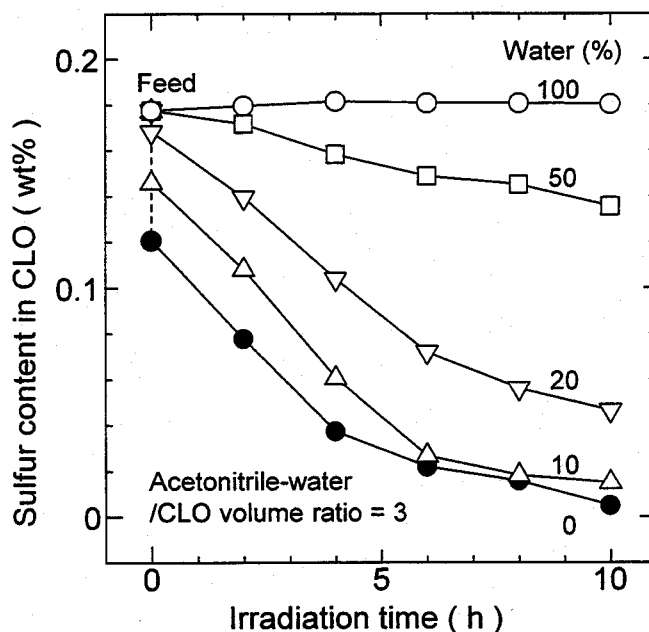

Figure 4-12. Effect of the addition of water on the time-course variation in the sulfur content in commercial light oil (CLO). $\lambda > 400$ nm.

The quantity of light oil recovered following 10 h photoirradiation was increased by adding water to the acetonitrile phase from 89% at 0% water content, to 94% at 20% water content, since the dissolution of hydrocarbons is suppressed owing to the increase in the polarity of acetonitrile phase. For the latter case, when the aromatics distributed into the acetonitrile phase were extracted by *n*-hexane and recovered, the total recovery of light oil obtained was up to 97%. In the case where UV light was irradiated, 87% of the light oil was totally recovered. Thus, the photodecomposition of aromatic hydrocarbons is actually suppressed by employing the indirect photooxidation using DCA, and thus a higher recovery of light oil is attained. The visible-light induced desulfurization of light oil with 10–20% of water/acetonitrile solution thus seems to be practicable and suggests that a recovered acetonitrile azeotropic mixture (containing 16% water) can be reused for the photooxidation.

3. Recovery of Aromatics and DCA, and Organization of the Process

3.1. Recovery of Aromatics and DCA from Acetonitrile

In the previous Chapter III, sulfur-free aromatic hydrocarbons were recovered easily by liquid–liquid extraction using nonpolar light paraffinic solvents, leaving the photooxidized sulfur-containing compounds in acetonitrile. DCA has a high boiling

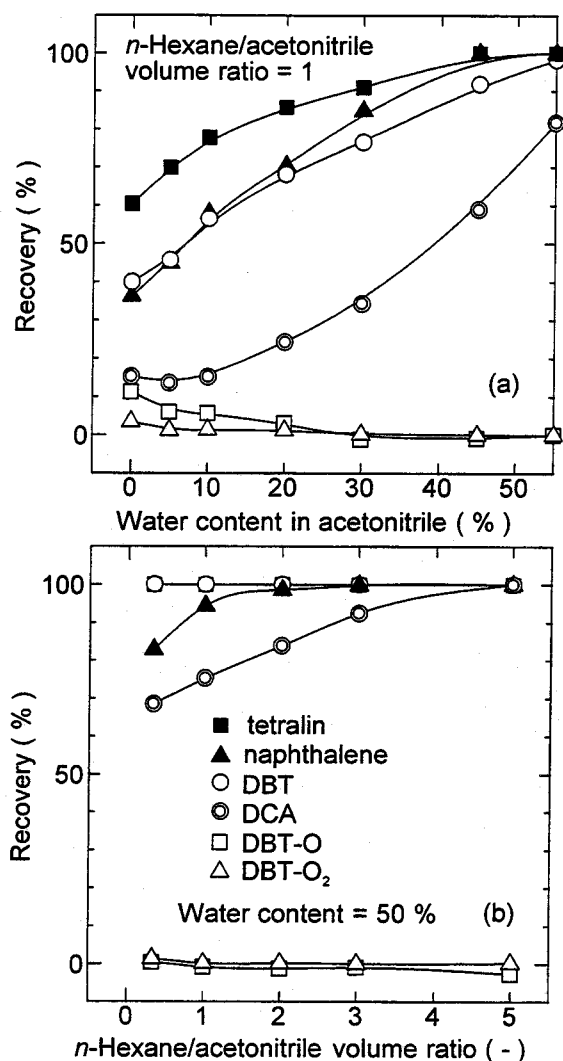

Figure 4-13. Comparison of the extractability of aromatic hydrocarbons, DCA, DBT, and its oxidized derivatives into the *n*-hexane phase from the acetonitrile phase, as a function of (a) water content in acetonitrile at the *n*-hexane/acetonitrile volume ratio = 1 and (b) *n*-hexane/acetonitrile phase volume ratio at the water content in acetonitrile = 50%.

point at 550 K, which is similar to those of the oxidized sulfur compounds, and thus is not able to be separated by simple distillation from acetonitrile solution. The DCA must therefore be recovered from acetonitrile solution by solvent extraction.

Tetralin (70 mM), naphthalene (35 mM), DCA (1×10^{-4} M), DBT (1 mM), DBT-O and DBT-O₂ (2 mM) were dissolved in acetonitrile, and were extracted with 20-fold volume of *n*-hexane. Ninety percent of the aromatics and the DBT were extracted, as expected, but only 50% of the DCA was recovered. The solubility of neutral aromatics is usually decreased by the addition of water. Thus, the effect of water content on the recovery of

DCA was examined experimentally, using a volume ratio of 1. The results are shown in **Figure 4-13a**. With increasing water content, the recovery of DCA increased, and 80% of DCA can be recovered by the addition of 55% water, whereas DBT-O and DBT-O₂ are not extracted at all into the *n*-hexane phase. **Figure 4-13b** shows the effect of the *n*-hexane volume ratio on the recovery of DCA at 50% water content. The recovery of DCA is increased with increasing volume ratio, and nearly 100% of DCA can be recovered at the volume ratio of 5. DCA and sulfur-free aromatic components therefore can be almost completely recovered by adding water to acetonitrile, followed by the extraction with *n*-hexane.

3.2. Recovery of DCA from Light Oil by Solid Adsorbents

When contacting the two phases, DCA is also distributed into the light oil. Since DCA has a relatively large polarity due to its cyano substituent groups, an adsorption procedure using solid adsorbent may be considered for its recovery purpose. DCA was dissolved in light oil, and adsorbents such as silica-gel, aluminum oxide and zeolite-13X were then added. The adsorption capacity for DCA by the three adsorbents was obtained as 0.931 g/kg, 0.287 g/kg and 0.372 g/kg, respectively. A highest adsorption of DCA was obtained using silica-gel. However, a significant quantity of silica-gel (70 g/L-oil) is required to recover 90% of the DCA from light oil when employing batch operation. As shown in **Table 4-1**, light oil contains a large quantity of aromatic components, which are also adsorbed onto the silica-gel. To achieve a high recovery of DCA, a column adsorption method was employed. The light oil (300 mL), containing saturated amount of DCA, was introduced to the top of the column, which was packed with 5 g of silica-gel. **Figure 4-14** shows the DCA content in the eluted fractions, and the amount of DCA adsorbed on the silica-gel. No elution of DCA was observed up to #30 fraction, and the adsorption capacity in this run was estimated as 2.4 g/kg-silica-gel. Therefore, by employing the column adsorption method, only 17 g/L of silica-gel was required for the complete adsorption of the DCA from the light oil.

An aqueous acetonitrile solution was employed for the desorption of DCA. The acetonitrile/water azeotropic mixture was fed to the top of the silica-gel column, on which the DCA was loaded. The DCA concentration in the eluent is plotted against the fraction number, as shown in **Figure 4-14**. Here the DCA was found to be almost completely

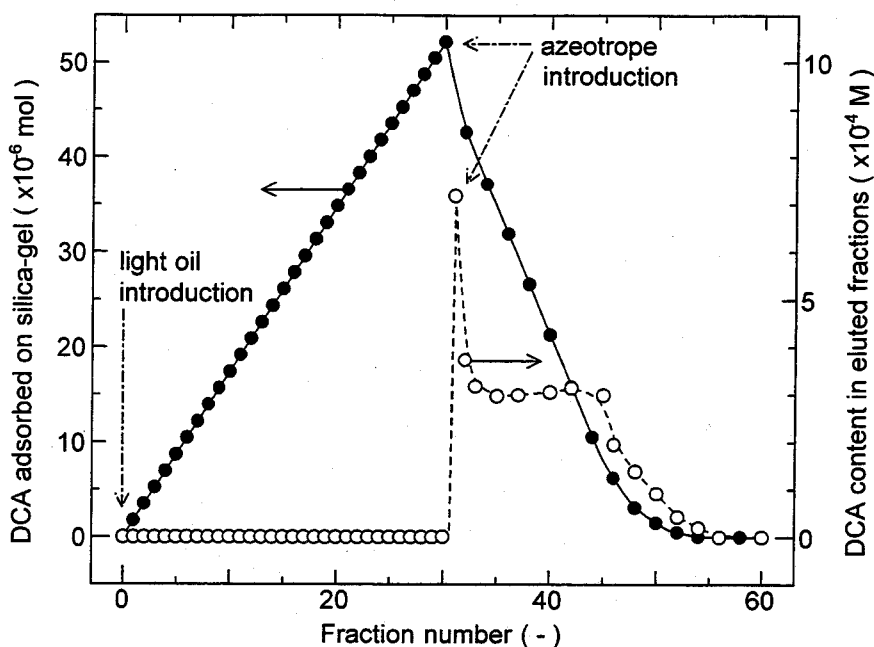

Figure 4-14. DCA content in eluted fractions (dotted line) and amount of DCA adsorbed on silica gel (solid line), when the light oil (300 mL), containing the saturated amount of DCA (5.2×10^{-5} mol), was fed for adsorption and the acetonitrile–water azeotropic mixture (300 mL) was fed for desorption to the top of the column (10 mL/fraction, [silicagel] = 5 g).

desorbed by 300 mL of azeotropic mixture solution. From these results, the DCA in light oil can be recovered into acetonitrile solution, thus allowing the resulting acetonitrile solution, containing DCA, to be reused for desulfurization without any additional treatment being required.

3.3. Organization of the Process

On the basis of the above results, a basic flow scheme for an overall process, involving the desulfurization and the recovery of aromatics, DCA and solvents, is conceived as shown in **Figure 4-15**. As compared with the process proposed previously for the use of UV light (Chapter III), two stages (section 4, adsorption of DCA) and (section 8, desorption of DCA) are newly added. This new process was examined to confirm its feasibility. The procedure and data obtained are shown in **Figure 4-16**.

(1) Commercial light oil (CLO) (100 mL, 81.9 g) and acetonitrile/water (14.7 wt%) azeotropic mixture (300 mL, 240 g) were introduced to the photoreactor with 10.4 mg of DCA, and photoirradiated ($\lambda > 400$ nm) for 10 h. (2) The acetonitrile solution obtained was mixed with 29.6 g of water, and extracted with 976 g of *n*-hexane. Ninety-nine

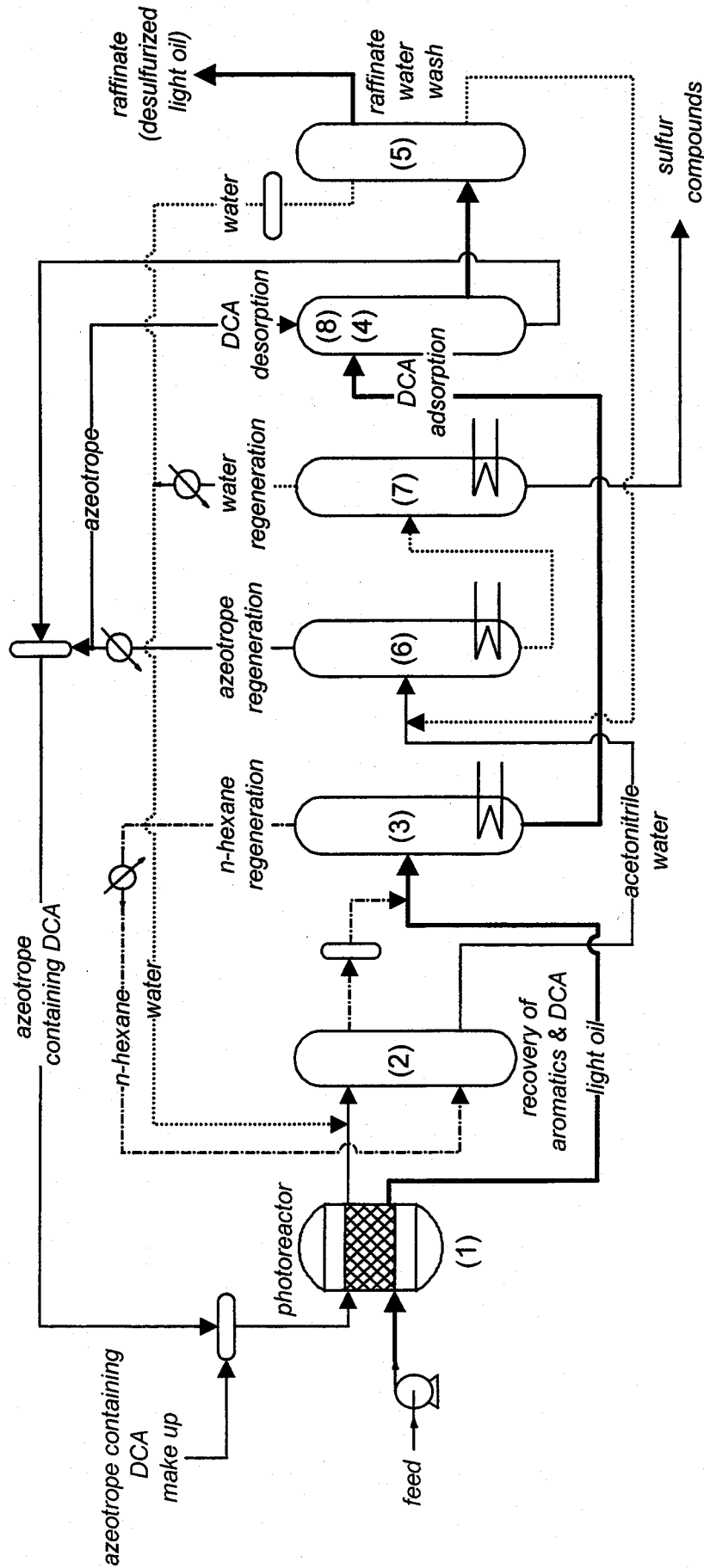

Figure 4-15. A basic flow scheme of the proposed desulfurization process. The individual sections are (1) desulfurization, (2) aromatics extraction, (3) distillation (*n*-hexane regeneration), (4) DCA adsorption, (5) water washing for light oil (recovery of acetone in light oil), (6) distillation (acetone-water azeotropic mixture regeneration), (7) distillation (water regeneration and condensation of sulfur), and (8) DCA desorption.

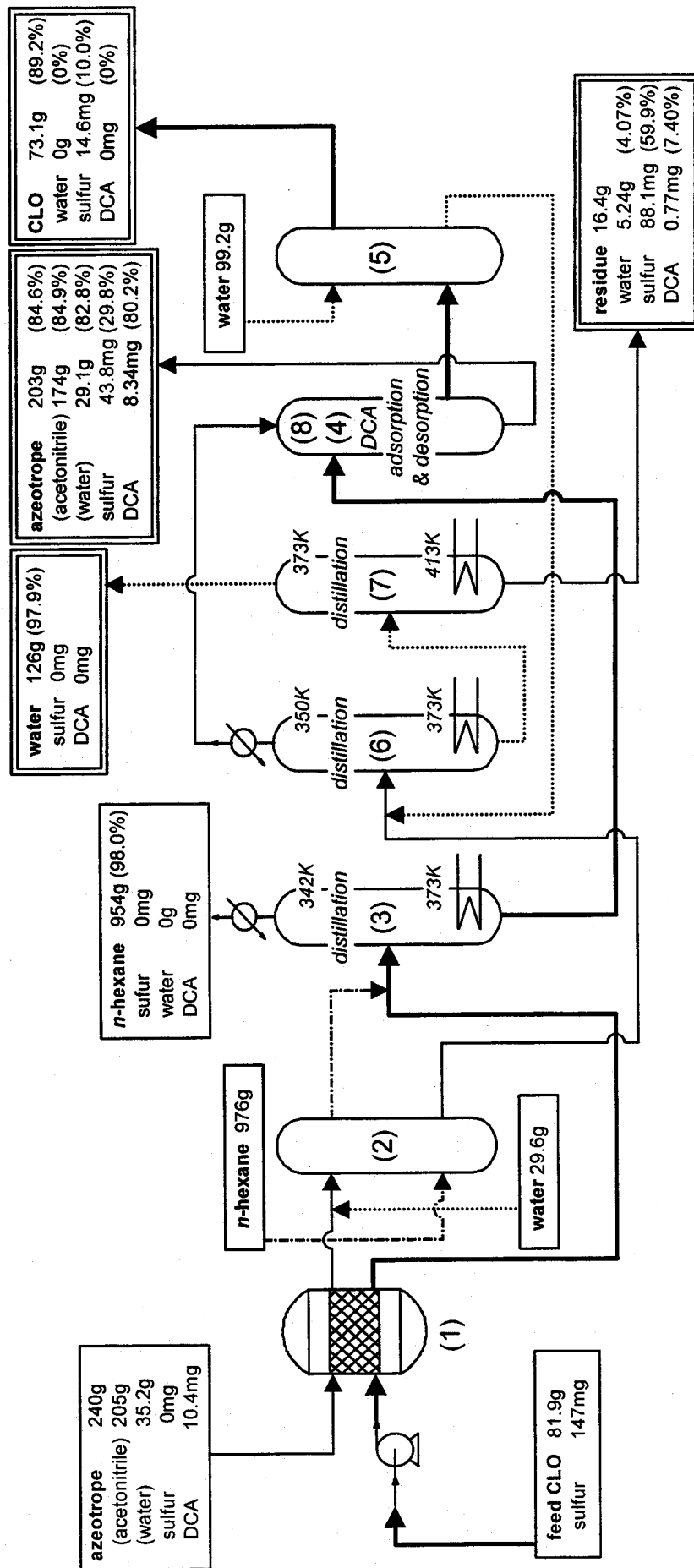

Figure 4-16. Material flow chart for CLO, sulfur, DCA, water, and acetonitrile-water azeotropic mixture as formulated from the results of the laboratory bench batch experiment representation of the process.

percent of the DCA was recovered to the *n*-hexane phase. (3) The *n*-hexane phase was mixed with CLO recovered from section 1, and was distilled without fractionation at 373 K. Pure DCA-free *n*-hexane product (bp. 342 K) was obtained with a yield of 98%. (4) The bottom product CLO from the distillation was introduced to the top of silica-gel (10 g) column. The DCA was totally adsorbed onto the silica-gel, and a DCA-free CLO product was eluted from the column. (5) The eluted CLO (73.6 g) was washed with water (99 g), and as a result, neither acetonitrile nor DCA was contained in CLO obtained. (6) The water phase recovered from section 5 was mixed with the acetonitrile/water mixture solution recovered from section 2, and was distilled under 373 K. A pure azeotropic mixture (bp. 350 K; water 14.7%) was obtained with a yield of 84%. (7) The resulting water phase from section 6 was then distilled at 413 K (section 7), and water (b.p. 373 K), containing no sulfur and DCA, was obtained with yield of 98%. Sixty percent of the sulfur fed was concentrated in the residue remaining at the bottom of the still. (8) The recovered azeotropic mixture was introduced to the top of the silica-gel column, on which the DCA (8.8 mg) had been adsorbed. The DCA was completely eluted and recovered into the azeotropic mixture.

The above operations were carried out on the laboratory bench scale and using individual batch processing stages. The fractional recoveries of the materials therefore are not so good as would be attainable in commercial operation. Using multistage operations, the fractional recoveries would be substantially improved. In the eluted azeotrope solution obtained in section 8, 30% of the sulfur fed was found to be contained. This is because the sulfur-containing compounds in the light oil are also adsorbed onto the silica-gel, owing to their large polarity, and are thus eluted by the azeotrope solution. The desulfurized CLO obtained from the process exhibits nearly the same distillation data as the feed CLO, as shown in **Table 4-1**. The proposed process consists of 8 stages of processing, of which 3 involve distillation separations. These however can be operated under conditions of atmospheric pressures and temperatures as low as 413 K, thus suggesting that the present process is both energy-saving and safe in operation, and is applicable to the satisfactory deep desulfurization of light oils.

Summary

Desulfurization process for light oil, based on a visible light-induced electron-transfer oxidation, spiked with electron-transfer photosensitizer, and liquid–liquid extraction, using an organic two-phase system, has been investigated, and the following results obtained.

(1) Sulfur-containing compounds, when dissolved in acetonitrile, were photooxidized most effectively in the presence of 9,10-dicyanoanthracene (DCA) with irradiation at wavelength of $\lambda > 400$ nm to form highly polarized compounds, which do not distribute into the nonpolar light oil phase. The photooxidation of sulfur-containing compounds proceeded with good selectivity even in the presence of large amount of aromatic hydrocarbons.

(2) When visible light irradiation in the presence of DCA was employed using oil/acetonitrile two-phase system, the deep desulfurization of commercial light oil was achieved, in which the sulfur content is reduced from 0.18 wt% to less than 0.005 wt% by 10 h photoirradiation. The 97% of light oil was recovered following photoirradiation by the present process, whereas only 87% of recovery was obtained in the process using UV irradiation. Since the straight-run light gas oil contains a larger quantity of aromatics, desulfurization was not so effective, although the quantity of sulfur removed is 5-fold greater than that for commercial light oil.

(3) The DCA dissolved in the acetonitrile is recovered by liquid–liquid extraction, together with sulfur-free aromatic hydrocarbons, leaving the photooxidized sulfur-containing compounds in acetonitrile phase. This is achieved by the addition of water to the acetonitrile, followed by contacting with a large quantity of light paraffinic hydrocarbons (*n*-hexane) as the stripping agent.

(4) DCA dissolved in light oil is strongly adsorbed onto silica gel. Although the adsorption of DCA is hindered by the aromatic hydrocarbons in the light oil, effective adsorption can be achieved employing a column adsorption method. The DCA adsorbed onto the silica gel adsorbent is totally desorbed by elution with an acetonitrile/water azeotropic mixture, which can be reused for further desulfurization.

(5) The desulfurization process, consisting of desulfurization and the recovery of

aromatics, DCA, and solvents, is formulated and was checked experimentally on the laboratory desk. The desulfurized light oils by the present process showed good distillation property as that of the feed light oil, thus demonstrating that the present process is applicable to the deep desulfurization of light oils.

Chapter V
Desulfurization of Catalytic-Cracked Gasoline
by Visible Light-Induced Electron-Transfer Oxidation
in an Organic Two-Phase Extraction System

Introduction

Catalytic-cracked gasoline (CCG) is produced by fluid catalytic-cracking units from vacuum gas oils or atmospheric residues in refineries, as shown in **Figure 1**. Since the CCG contains a high concentration of olefins, this is usually mixed with straight-run light naphtha (gasoline) to improve the octane number of the commercial gasoline. The CCG contains a high level of sulfur, such that the desulfurization is of great importance from the environmental point of view. The sulfur content of gasoline is limited presently to 100 ppm in Japan and 200 ppm in Europe, and these specifications will certainly be tightened on average to 30 ppm soon (Upson and Schnaith, 1997). A catalytic hydrodesulfurization (HDS) method is presently employed industrially for reducing the sulfur content of CCG. The HDS method can easily desulfurize sulfur-containing compounds such as thiols, disulfides, and thiophenes, but causes a simultaneous hydrogenation of the olefins. Thus, this method must inevitably lead to a substantial octane loss for the CCG (Hatanaka et al., 1997a and b). A novel, more selective, desulfurization process for CCG is therefore strongly required.

A desulfurization process for light oils, based on visible light-induced photooxidation using 9,10-dicyanoanthracene (DCA) and organic two-phase liquid-liquid extraction, was described in Chapter IV. In this chapter, this has been applied to the desulfurization of CCG by expecting the sulfur-containing compounds to be photooxidized selectively by DCA even in the presence of olefins. The photoreactivity of typical sulfur-containing compounds contained in CCG and their photoproducts in the photooxidation, when spiked with DCA in acetonitrile solution, are studied in detail. The effect of the presence of olefins on the photooxidation of the sulfur-containing compounds and on their selectivity is also studied. Finally, the properties of CCG produced by the present process are measured and the applicability to the refining process for CCG is examined.

Table 5-1. Properties and Composition of Catalytic-Cracked Gasoline (CCG)

		feed	following desulfurization
density @ 288 K	(g/mL)	0.7318	0.7383
total sulfur	(ppm)	99.4	28.3
composition ^a	(vol%)		
saturates		32.7	34.6
naphthenes		7.9	9.7
aromatics		16.4	15.6
olefins		43.0	40.1
distillation temperature ^a	(K)		
IBP		314.5	328.0
10 vol%		331.0	338.5
30 vol%		352.0	357.0
50 vol%		368.0	377.0
70 vol%		393.0	404.5
90 vol%		438.5	445.5
95 vol%		454.5	458.0
FBP		469.5	469.5
research octane number		90.6	88.1

^a By the JIS K 2536 gas-chromatographic method.

Experimental Section

1. Materials

9,10-Dicyanoanthracene (DCA) was purchased from Tokyo Kasei Co., Ltd. Sulfur-containing compounds and other chemicals used in this study were supplied by Wako Pure Chemical Industries, Ltd. These materials were used without further purification. CCG, produced from vacuum gas oil, was supplied by Cosmo Petroleum Institute. The properties of CCG are summarized in **Table 5-1**.

2. Apparatus and Procedure

CCG was mixed vigorously with acetonitrile solution using a magnetic stirrer at volume ratios varying from 3/9 to 9/3 mL, using total solution volumes of 12 mL within a Pyrex glass test tube (25 mL). The required quantity of DCA was added to each solution and each tube stoppered using a rubber septum cap. Oxygen was then bubbled through the solution for 5 min and each solution photoirradiated by a high-pressure mercury lamp (300 W, Eikohsha Co., Ltd., Osaka), filtered through a 3 wt% aqueous NaNO₂ filter

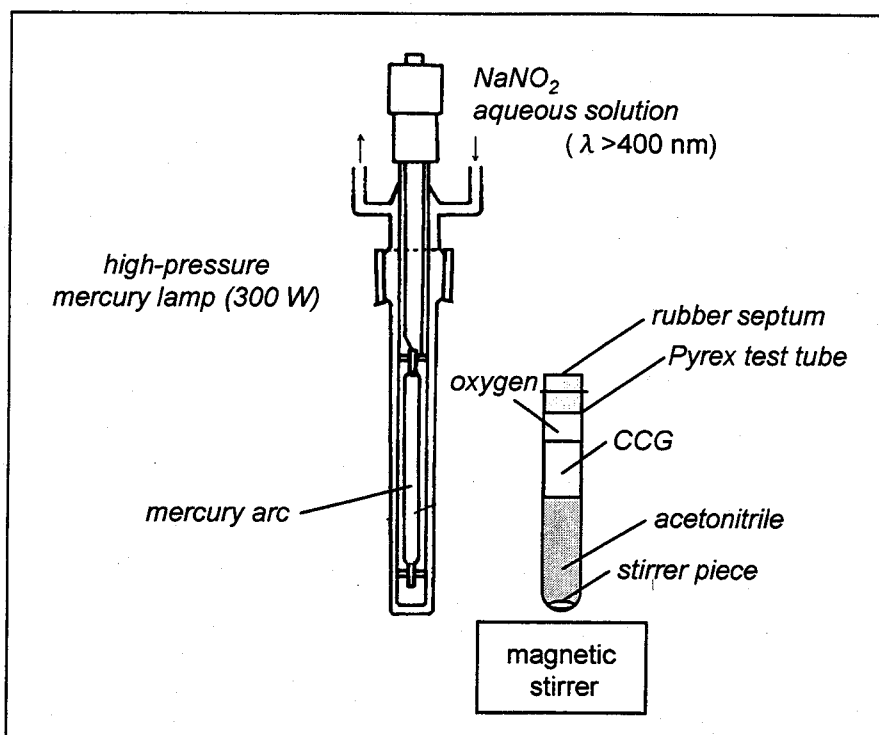

Figure 5-1. Schematic representation of photoirradiation instrument.

solution, to give light wavelength rejection of less than 400 nm, as in Chapter IV. The schematic representation of photoirradiation instrument is shown in **Figure 5-1**. The test tubes were placed at a distance of 5 cm from mercury lamp. Homogeneous acetonitrile solutions (12 mL), containing the starting sulfur compounds and DCA, were also employed for the photoreaction studies.

3. Analysis

The full procedure has been described in Chapter IV, concerning the desulfurization of light oils, and only a brief description of the method is presented here. The total sulfur content in the CCG was analyzed using an inductively coupled argon plasma atomic emission spectrophotometer (Nippon Jarrell-Ash ICAP-575 Mark II). The concentrations of the individual sulfur-containing compounds in CCG were quantitatively analyzed by a gas chromatograph–atomic emission detector (GC-AED, Hewlett-Packard 6890, equipped with AED G2350A), and in accordance with the procedure of Albro et al. (1993). An identification of the sulfur-containing compounds was carried out using GC-MS, as described in Chapter III. The concentrations of the sulfate anion were analyzed by ion chromatography (Shimadzu LC-6A, equipped with conductivity detector CDD-6A), and with an IC-AI column.

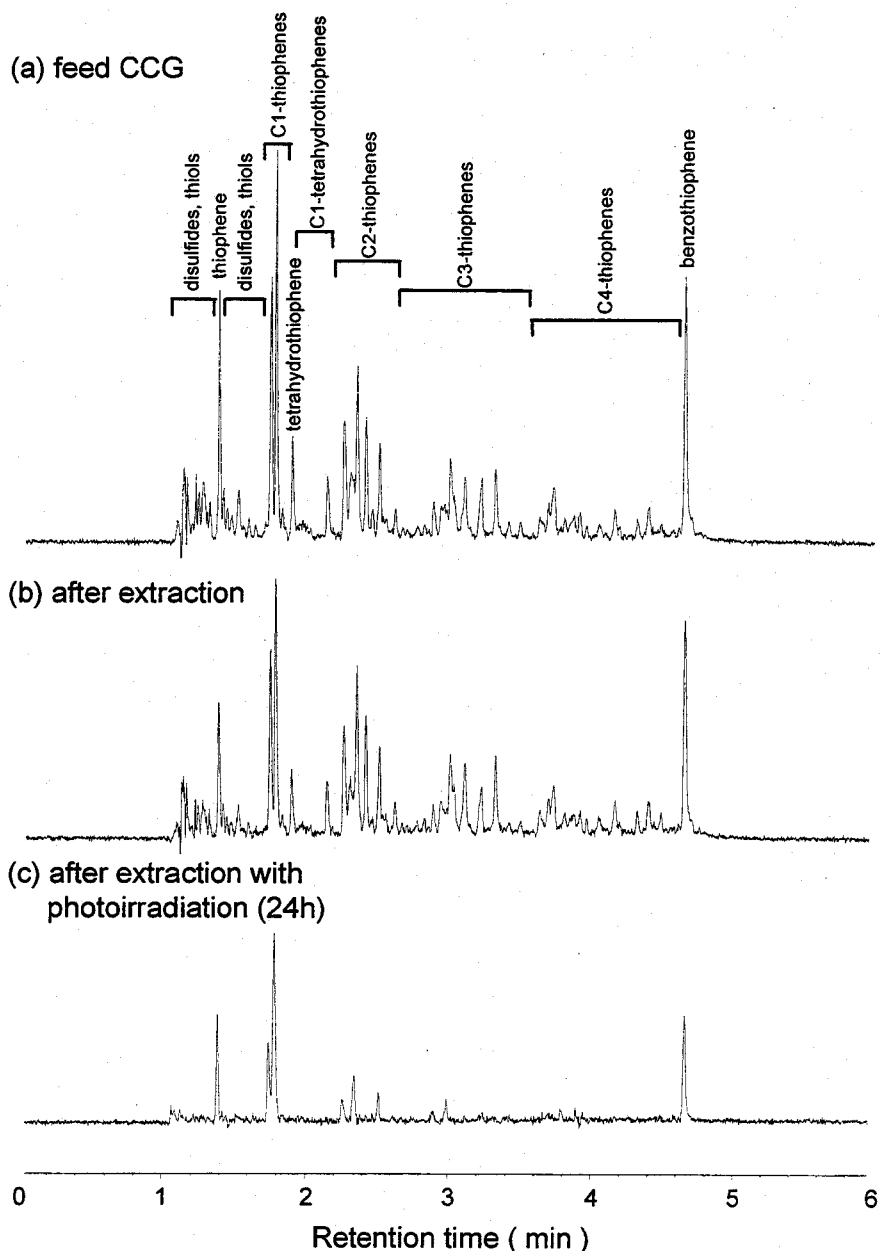

Figure 5-2. GC-AED (sulfur, 181 nm) chromatograms for CCG: (a) feed, (b) after simple extraction (acetonitrile/CCG volume ratio = 3), and (c) after extraction for 24 h photoirradiation ($\lambda > 400$ nm).

Results and Discussion

1. Electron-Transfer Photooxidation of Sulfur-Containing Compounds Using DCA in Acetonitrile

1.1. Photooxidation of Sulfur-Containing Compounds

GC-AED analyses were carried out to acquire detailed information on the sulfur-containing compounds contained in CCG. The sulfur-specific GC-AED gas chromatogram obtained is shown in **Figure 5-2a**, and the quantity of each compound, as

Table 5-2. Quantities of Sulfur-Containing Compounds in (i) Feed Catalytic-Cracked Gasoline (CCG) and the Oils (ii) Following Simple Extraction (Acetonitrile/CCG Volume Ratio = 3) and (iii) Following Extraction Combined with 24 h Photoirradiation ($\lambda > 400$ nm) in the Presence of DCA (The Remaining Percentage of Each Component for Feed is Set as 100%)

sulfur compounds	(i) feed CCG	(ii) after extraction		(iii) after extraction with photoirradiation	
	sulfur(ppm)	sulfur(ppm)	remaining(%)	sulfur (ppm)	remaining(%)
thiophene	5.3	2.9	54.7	2.3	43.4
disulfides, thiols	5.7	3.1	54.4	0.8	14.0
C1-thiophenes	15.1	11.2	74.2	7.4	49.0
tetrahydrothiophene	2.8	1.8	64.3	0.2	7.14
C1-tetrahydrothiophenes	4.1	3.1	75.6	0.6	14.6
C2-thiophenes	21.1	18.9	89.6	3.7	17.5
C3-thiophenes	19.6	19.2	98.0	3.0	15.3
C4-thiophenes	16.1	16.0	99.4	2.2	13.7
benzothiophene	9.6	7.8	81.3	2.5	26.0
total sulfur	99.4	84.0	—	22.7	—

determined by GC-MS, is summarized in **Table 5-2**. The CCG, with a total sulfur content of approximately 100 ppm, contained mainly alkyl-substituted thiophenes (72%). Disulfides, thiols, tetrahydrothiophenes, and benzothiophene are also contained in small amounts. The sulfur-containing compounds listed in **Table 5-3** were therefore used as model compounds. In this procedure, an acetonitrile solution, containing each pure sulfur compound with DCA, was photoirradiated with visible light of wavelength $\lambda > 400$ nm, and the photoproduct and photoreactivity of each compound was then examined.

The electron-transfer photooxidation process for sulfur-containing compounds spiked with DCA is described in Chapter IV and schematically shown in **Figure 4-3**, and only a brief description is made here. The photooxidation is initiated by the fluorescence quenching of DCA by the sulfur compound. In polar solvents, the formed exciplex [DCA...sulfur compound]^{*} is dissociated into the separated radical ions, DCA^{•-} and [sulfur compound]^{•+}. The molecular oxygen is then reduced by electron transfer from DCA^{•-} to form a superoxide anion (O₂^{•-}). Finally, the radical ion pairs,

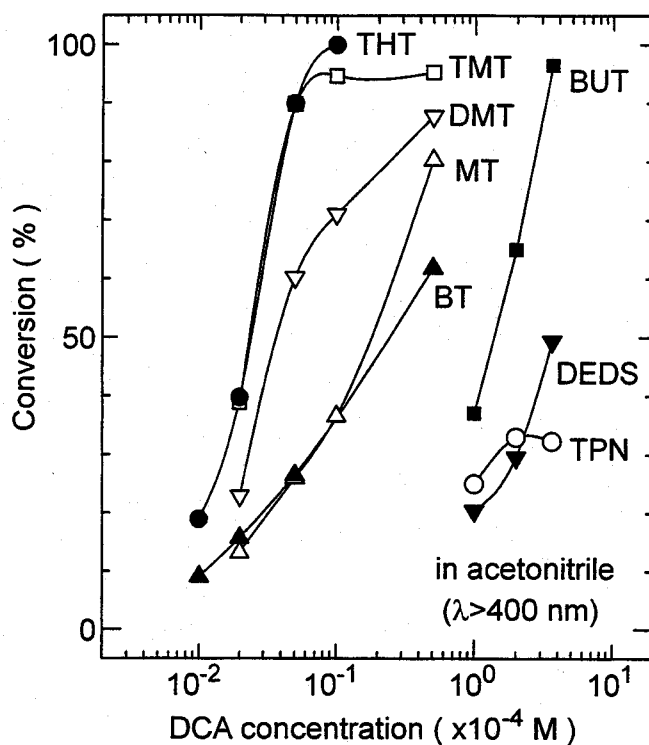

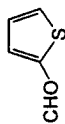
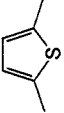
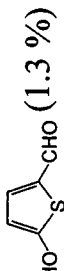
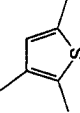
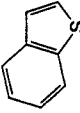
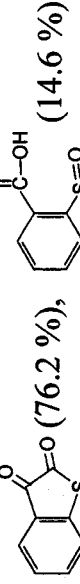
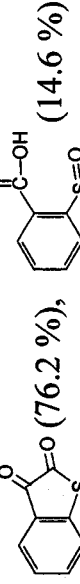



Figure 5-3. Effect of DCA concentration on the conversion for the various sulfur-containing compounds in acetonitrile, following 12 h photoirradiation ($\lambda > 400$ nm). THT, tetrahydrothiophene; TMT, 2,3,5-trimethylthiophene; DMT, 2,5-dimethylthiophene; MT, 2-methylthiophene; BT, benzothiophene; BUT, 1-butanthiol; DEDS, diethyl disulfide; TPN, thiophene.

[sulfur compound] \cdot^+ and $O_2\cdot^-$, are combined to form oxidized products. **Figure 5-3** shows the effect of DCA concentration following 12 h photoirradiation on the resulting conversion for the various sulfur-containing compounds, and the conversion of compounds was found to increase with increasing DCA concentration. However, only 30% of thiophene (TPN) was converted, even in the presence of DCA (5×10^{-4} M), showing that thiophene was the most difficult compound to be photooxidized. Other alkyl-substituted thiophenes, such as 2,3,5-trimethylthiophene (TMT), 2,5-dimethylthiophene (DMT), and 2-methylthiophene (MT), were photooxidized more easily than the unsubstituted thiophene. The conversions of these compounds increased with increasing number of the methyl substituents, with a ranking order of TMT > DMT > MT > TPN. **Table 5-3** shows the fluorescence quenching rate constants, k_q , for the various sulfur-containing compounds in acetonitrile with DCA. The values of k_q for the thiophenes were found to increase with increasing number of methyl substituents.

Table 5-3. Fluorescence Quenching Rate Constants for Various Sulfur-Containing Compounds and Their Photoproducts, Following 12 h of Photoirradiation ($\lambda > 400$ nm) in Acetonitrile in the Presence of DCA (1×10^{-4} M)

sulfur compounds	structure	k_q ($\times 10^{10}$ Lmol $^{-1}$ s $^{-1}$)	conversion (%)	products (yields, %)
thiophene (TPN)		0.025	25.0	SO $_4^{2-}$ (60.6 %)
2-methylthiophene (MT)		1.169	90.7	SO $_4^{2-}$ (26.8 %),  (2.5 %)
2,5-dimethylthiophene (DMT)		1.433	91.2	SO $_4^{2-}$ (45.2 %),  (1.3 %)
2,3,5-trimethylthiophene (TMT)		1.704	93.9	SO $_4^{2-}$ (55.0 %)
benzothiophene (BT)		1.419	60.5	 (76.2 %),  (14.6 %)
tetrahydrothiophene (THT)		1.697	100	SO $_4^{2-}$ (10.2 %),  (38.9 %)
1-butanethiol (BUT)	<i>n</i> -C $_4$ H $_9$ -SH	0.202	37.1	SO $_4^{2-}$ (10.5 %), Bu-SO $_2$ -S-Bu (23.2 %)
diethyl disulfide (DEDS)	C $_2$ H $_5$ -S-S-C $_2$ H $_5$	1.575	20.4	SO $_4^{2-}$ (21.3 %), Et-SO $_2$ -S-Et (72.7 %) Et-SO-SO-Et (4.1 %), Et-SO $_2$ -SO $_2$ -Et (2.6 %)

This indicates that the formation rate of [sulfur compound]⁺ is accelerated by the methyl substituents. Therefore, the order of conversion for the thiophenes is attributable to their fluorescence quenching rates.

Tetrahydrothiophene (THT) was photooxidized rather faster than 2,3,5-trimethylthiophenes, and almost 100% conversion was attained in the presence of DCA (1×10^{-5} M), although the former has smaller k_q values than the latter. The photoproducts for the various sulfur-containing compounds are listed in Table 5-3. GC-AED analyses for all of the resulting thiophene samples hardly showed a peak containing the sulfur atom, except for a small amount of thiophene-2-carbaldehyde and -2,5-dicarbaldehyde. The main photoproducts for all the thiophenes were found to be sulfate anions. Thiophene sulfoxides and sulfones were not found in the present experiments. Tetrahydrothiophene (THT) produced a large amount of the corresponding sulfone during photoirradiation, but this then decreased with increasing irradiation time with an according sulfate anion formation. Tetrahydrothiophene sulfoxide and sulfone are known to be unstable under photoirradiation (Still, 1988), and therefore the sulfoxide and sulfone produced are possibly further photodecomposed to finally form the sulfate anion. From these results, photooxidation for thiophenes and THT proceeds via different mechanisms. Thiophenes can act as *n*-type donors by the lone pair electron of the sulfur atom or as π -type donors by the delocalized electron of the aromatic rings. Because a charge density of the sulfur atom on the thiophenes is very small, the electron withdrawal occurs on the thiophene ring, and the oxidation occurs on the thiophene ring or methyl substituent, whereas the electron withdrawal of the THT occurs on the sulfur atom. The methyl substituent is more difficult to be oxidized than the sulfur atom, and the oxidation of 2,3,5-trimethylthiophene thus occurs more slowly than that of the THT, although the k_q value for the former is larger than that for the latter.

Photoproducts of other sulfur compounds were also identified. 1-Butanthiol (BUT) produced mainly dibutylthiosulfonate (Bu-SO₂-S-Bu) and the sulfate anion. As reported in the direct photooxidation of BUT by UV irradiation, unoxidized dibutyl disulfide (Bu-S-S-Bu) was detected as an intermediate during photoirradiation (Banchereau et al., 1997). These two photoproducts therefore seem to be produced by

further photooxidation of dibutyldisulfide. Diethyldisulfide (DEDS) produced two main photoproducts, diethylthiosulfonate (Et-SO₂-S-Et) and the sulfate anion, and two minor products, diethyl-*vic*-disulfoxide (Et-SO-SO-Et) and *vic*-disulfone (Et-SO₂-SO₂-Et). Banchereau et al. (1997) have reported that the photoirradiation of DEDS in aqueous acetonitrile solution leads to the formation of sulfuric acid, consequent to the photolysis of thiosulfonate. In the present experiment, the thiosulfonate formed also is likely to be photodecomposed directly to finally form the sulfate anion. Because most of the photoproducts identified are highly polarized compounds, this suggests that they will be insoluble in the nonpolar gasoline. During photoirradiation of the DCA/acetonitrile solution, no degradation or decrease in the fluorescence intensity of DCA was observed, thus suggesting that the DCA can be recovered and reused for photooxidation.

1.2. Photooxidation of Sulfur-Containing Compounds in the Presence of Olefins

As shown in Table 5-1, olefins form the main constituents of CCG, and these are very soluble in acetonitrile owing to their high polarity. Because the olefins are attributed to the octane number of CCG, the photooxidation of the sulfur-containing compounds in the presence of the olefins was also investigated. 1-Octene and 1,7-octadiene were employed as models for the mono- and di-olefins, respectively (Hatanaka et al., 1997). In this procedure, 100 mM of each olefin was added to the acetonitrile together with 10 mM of pure sulfur-containing compound and then the mixture was photoirradiated for 12 h in the presence of DCA. The results are summarized in Table 5-4, where the selectivity for the conversion of each sulfur compound is defined as,

$$selectivity = \frac{[\text{conversion of sulfur compound}]}{[\text{conversion of sulfur compound}] + [\text{conversion of olefin}]} \quad (5-1)$$

In the presence of 1-octene and 1,7-octadiene, the conversions obtained for TPN, MT, BT, and THT were found to be decreased slightly. This is because the fluorescence of DCA is quenched competitively by these olefins, with rate constants of $k_{q,1\text{-octene}} = 0.003 \text{ L mol}^{-1} \text{ s}^{-1}$ and $k_{q,1,7\text{-octadiene}} = 0.019 \text{ L mol}^{-1} \text{ s}^{-1}$, as follows:

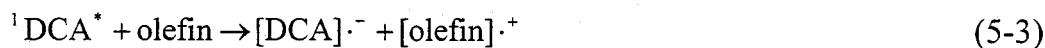
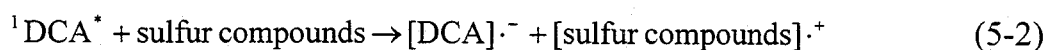

The conversions for DMT, TMT, BUT, and DEDS, on the contrary, increased in the presence of olefins. Because the oxidation potentials for the olefins are lower than those

Table 5-4. Conversion and Conversion Selectivity for the Various Sulfur-Containing Compounds in the Presence of Olefins (1-Octene and 1,7-Octadiene), Following 12 h Photoirradiation ($\lambda > 400$ nm) with DCA ([Sulfur Compound]_{initial} = 10 mM, [Olefin] = 100 mM, and [DCA] = 1.0×10^{-4} M)

sulfur compounds	no addition	with 1-octene		with 1,7-octadiene	
	conversion (%)	conversion (%)	selectivity	conversion (%)	selectivity
TPN	25.0	21.6	0.937	25.6	0.868
MT	90.7	77.4	0.878	90.7	0.897
DMT	91.2	99.6	0.929	99.5	0.990
TMT	93.9	100	1	100	0.986
BT	60.5	48.4	0.934	36.8	0.912
THT	100	99.6	1	99.4	1
BUT	37.1	96.4	0.947	98.4	1
DEDS	20.4	21.4	0.977	20.5	1

for the sulfur compounds, the electron transfer from sulfur compound to olefin cation radical occurs exothermically (Mattes et al., 1982), as follows:

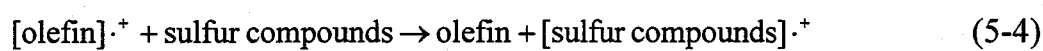

As a result, electron withdrawal from the sulfur-containing compounds is accelerated, and thus a high conversion for these sulfur compounds is likely to be obtained in the presence of olefins. Mizuno et al. (1985) have reported that the photooxidation of diphenyl cyclopropan, spiked with DCA, is accelerated by the presence of aromatic hydrocarbons according to a similar mechanism. However, it is difficult to explain what it is about the structure of a particular compound that results in an increase or decrease in the conversion for that compound. The selectivity values for all the sulfur compounds still remain greater than 0.85, even in the presence of a 10-fold increase in the olefin quantities. The proposed photochemical process should therefore allow selective photooxidation for sulfur-containing compounds in CCG.

2. Photochemical Desulfurization of CCG Using DCA

2.1. Effect of DCA on the Desulfurization of CCG

The effect of DCA on the desulfurization of CCG was studied with acetonitrile as the extraction solvent. CCG contains a high proportion of both aromatics and olefins, as

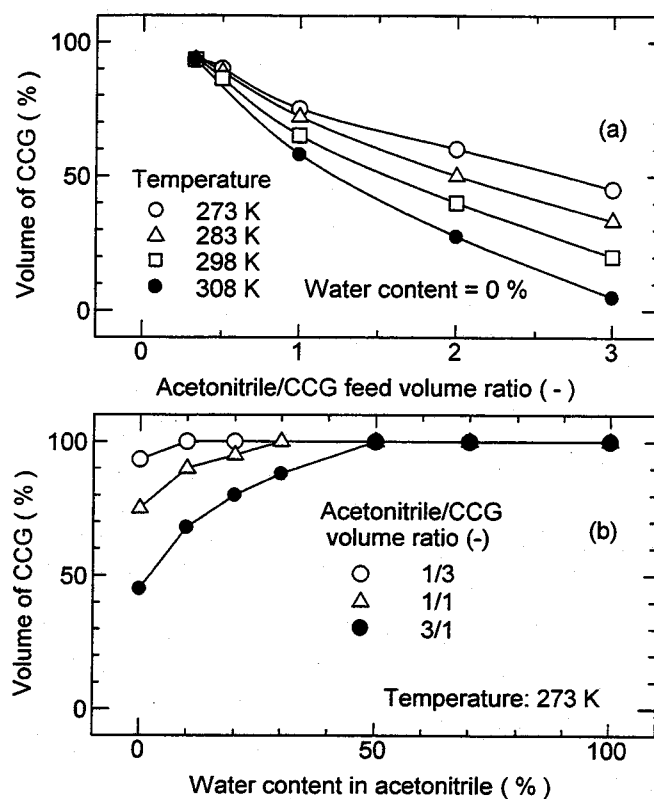

Figure 5-4. Effects of the (a) acetonitrile/CCG feed volume ratio and temperature and (b) water content in the acetonitrile phase on the resulting volume of CCG.

shown in **Table 5-1**. When CCG contacts acetonitrile, most of these compounds are distributed into the acetonitrile phase. **Figure 5-4a** shows the effects of the acetonitrile/CCG feed volume ratio and temperature on the resulting volume of CCG. The CCG volume is seen to decrease with increasing acetonitrile/CCG feed volume ratio. Although the CCG volume increased slightly with reduced temperature, only a residual 45% CCG volume remained under the conditions of a feed volume ratio of 3 and 273 K. In the case of a light oil/acetonitrile two-phase system, the light oil recovery and the phase separation were actually improved by the addition of some water (Chapter IV). As shown in **Figure 5-4b**, when water was thus added to the CCG/acetonitrile two-phase system, the CCG recovery was increased markedly, and almost 100% CCG was recovered for a water content of 50% and 273 K. In the following photoirradiation experiments for CCG, therefore, the CCG after desulfurization was recovered by the addition of an equal volume of water as that of the feed acetonitrile to the two-phase system and at a temperature of 273 K.

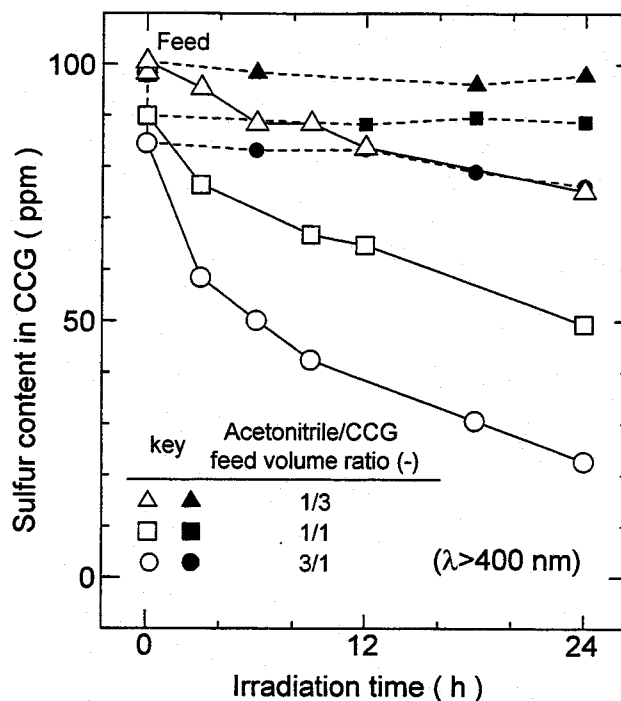

Figure 5-5. Time-course variation in the sulfur content of CCG, using the CCG/acetonitrile two-phase system, when combined with photoirradiation ($\lambda > 400$ nm) both in the presence and absence of DCA. Closed key, without DCA; open key, with DCA.

Both the CCG and the acetonitrile were saturated with DCA ($[DCA]_{CCG} = 1.6 \times 10^{-4}$ M and $[DCA]_{acetonitrile} = 3.9 \times 10^{-4}$ M) and the resulting solutions mixed and then photoirradiated. The time-course variation in the sulfur content of the CCG is shown in **Figure 5-5**. The data points, shown for an irradiation time of zero, are those obtained simply by mixing the two phases without photoirradiation and indicate the equilibrium sulfur concentrations for the two phases. In the absence of DCA, the decrease in sulfur content obtained was very small. In the presence of DCA, the sulfur content, however, decreased considerably with irradiation time, and at a volume ratio of 3/1, the sulfur content was decreased from 100 ppm to less than 30 ppm following 24 h photoirradiation. The sulfur content of 30 ppm is in accordance with the value of prospective regulation, thus indicating that the present photoprocess is effective both for the desulfurization of CCG as well as for light oils, as described in Chapter IV. Following desulfurization, the CCG obtained was found by GC-AED analysis to contain only unreacted sulfur-containing compounds, as indicated by **Figure 5-2c**. Thus, the photooxidized sulfur-containing compounds are essentially removed into acetonitrile solution.

The variation in the composition of the sulfur-containing compounds in CCG, following simple extraction and 24 h photoirradiation (acetonitrile/CCG volume ratio = 3), is shown in **Table 5-2**. With simple extraction, thiophene, disulfides, thiols, and tetrahydrothiophene are readily extracted into the acetonitrile phase. The remaining proportion for tetrahydrothiophenes and thiophenes has a tendency to increase with an increase in the carbon number of the alkyl substituents, because the alkyl substituents tend to decrease the polarity of sulfur compounds (Chapter III). Following photoirradiation, both tetrahydrothiophene and C1-tetrahydrothiophenes were readily desulfurized and reduced in concentration to 7.1% and 15%, respectively. Although the C2-, C3-, and C4-thiophenes were difficult to remove to the acetonitrile phase by simple extraction, both of these compounds were reduced to less than 20% concentration following photoirradiation. Thiophene and C1-thiophenes however were hardly desulfurized, and as much as 43% and 49% remained following photoirradiation. This is because these compounds are difficult to photooxidize by DCA.

2.2. Effect of Water on the Desulfurization of CCG and the Recovery of DCA

Following the desulfurization of CCG by the present process, 50% water was added to the mixture to enhance the phase separation. The effect of water on the desulfurization of CCG was therefore investigated. A saturated amount of DCA was added in both CCG and acetonitrile/water solution and the solutions were photoirradiated. As shown in **Figure 5-6**, the desulfurization yield for CCG decreased with increasing water content. The addition of the water lowers the solubility of the sulfur compounds into the acetonitrile phase and the DCA, as shown in **Figure 5-7**. The conversion of the sulfur-containing compounds decreased by decreasing both the initial concentration of the sulfur compounds and DCA, thus resulting in the low desulfurization yield for CCG. In addition, the fluorescence quenching rate constants, k_q , for the sulfur compounds are decreased by increasing the water content of the acetonitrile (Chapter IV). This also seems to contribute to the low desulfurization yield. For water contents in the region of 10–20%, however, the sulfur content could still be decreased effectively to less than 30 ppm, following 48 h photoirradiation. Acetonitrile can be recovered by distillation as an azeotropic mixture (acetonitrile/water, 84/16 v/v (bp 350 K)), as described in Chapter IV.

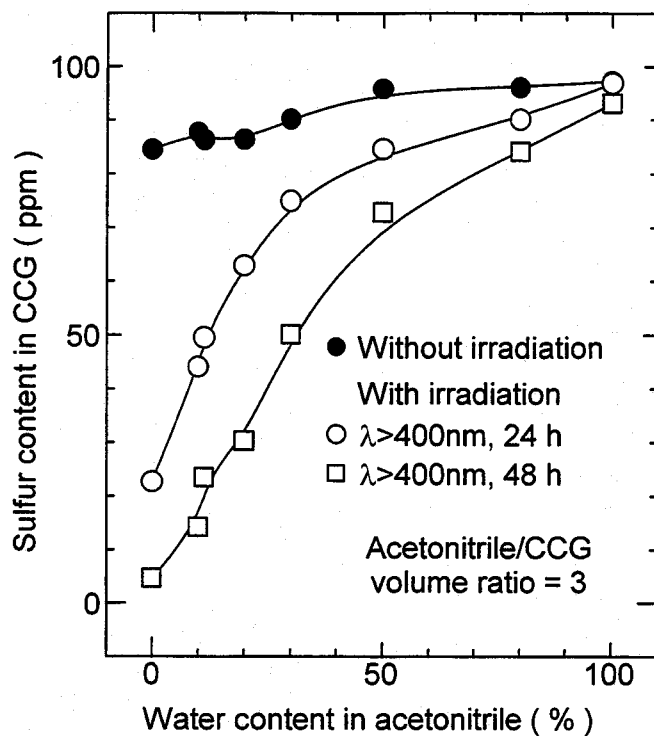

Figure 5-6. Effect of the addition of water to acetonitrile on the sulfur content in a CCG, following simple extraction, extraction with 24 h photoirradiation, and 48 h photoirradiation. $\lambda > 400 \text{ nm}$.

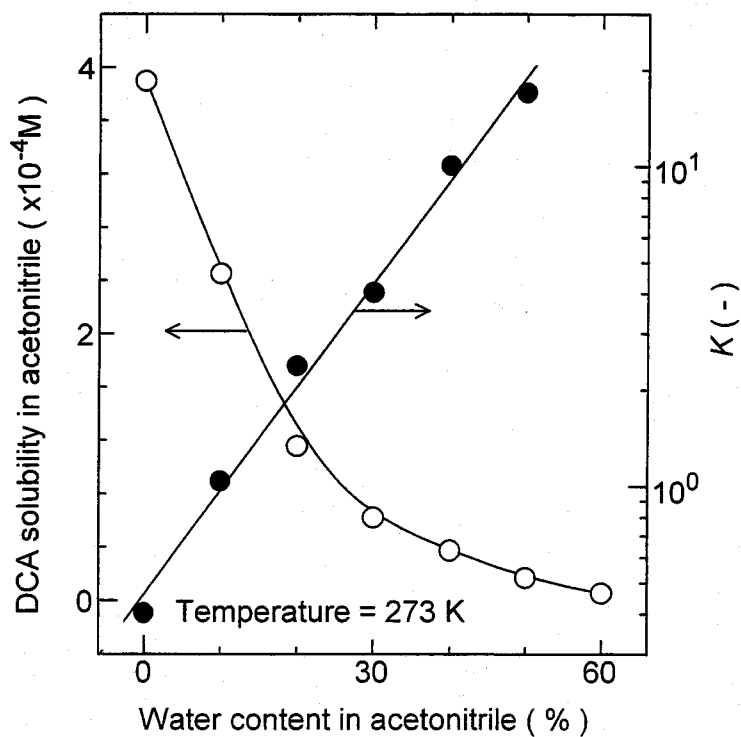

Figure 5-7. Effects of the addition of water to acetonitrile on the maximum solubility of DCA and the distribution coefficient, K , for DCA in a CCG/acetonitrile–water two-phase mixture.

Table 5-5. Variation in the DCA Concentration in Both the CCG and Acetonitrile Phase on the Recovery of DCA (273 K) (The Initial Volume of CCG and Acetonitrile is 3 and 9 mL, Respectively)

		(i) after photoirradiation	(ii) after the addition of water	(iii) after contact with new CCG
DCA content in CCG	($\times 10^{-4}$ M)	1.557	1.649	1.022
	(μg)	106.6	112.9	70.0
DCA content in acetonitrile	($\times 10^{-4}$ M)	3.868	0.235	0.065
	(μg)	794.5	96.6	26.6
solid DCA precipitated	(μg)		691.6	

Thus, the azeotropic mixture regenerated by distillation is directly reusable for further desulfurization.

The photoproducts of the sulfur-containing compounds in acetonitrile have high boiling points ranging from 540 to 600 K, which overlap the sublimation point of DCA (553 K). A recovery procedure for the DCA dissolved in acetonitrile was therefore investigated. As shown in **Figure 5-7**, the solubility of DCA in acetonitrile decreases with an increasing water content. CCG was contacted with acetonitrile/water mixtures, and a distribution coefficient, K , defined as the ratio of the DCA concentration in CCG to that of the DCA in the acetonitrile/water mixture was determined. The value of K was found to increase with increasing water content from a value of 0.4 at 0% water to 17.0 at 50% water. Therefore, in principle, following desulfurization, the DCA dissolved in acetonitrile may be recovered by the addition of water, followed by contact with CCG. This procedure was then carried out experimentally to examine its feasibility, and the results are summarized in **Table 5-5** according to the following procedure. (i) The CCG and acetonitrile mixture, containing a saturated amount of DCA, was photoirradiated for 48 h at the volume ratio of 1/3. (ii) An equal volume of water relative to the acetonitrile was added to the two-phase system. Because the solubility of DCA was decreased, solid DCA (0.69 mg) appeared on the interface of the two phases. This solid could be recovered simply by filtration. (iii) New CCG was then contacted with the resulting acetonitrile solution, showing that most of the remaining DCA in the acetonitrile solution

can be recovered to the CCG phase. The 97% of DCA initially dissolved in acetonitrile phase was finally recovered, demonstrating that these procedures can be used for the recovery of DCA.

2.3. Organization of the Process

On the basis of the above results, a basic flow scheme for an overall process, involving desulfurization and the recovery of both DCA and solvents, was formulated and this is shown in **Figure 5-8**. (1) Feed CCG is first used for the extraction and recovery of DCA from the acetonitrile/water mixture, after which the CCG is sent to the photoreactor. (2) The CCG is mixed with an azeotropic mixture containing DCA and then the mixture photoirradiated under conditions of air-bubbling. (3) Water is added to the two-phase system following desulfurization to enhance phase separation and to precipitate DCA at a temperature of 273 K. The DCA precipitate is recovered by filtration, and the residual acetonitrile/water and DCA mixture recovered is sent to the DCA extractor (1). (4) The desulfurized CCG containing DCA is separated from the contained DCA by evaporation, leaving DCA as the bottom product. (5) The resulting acetonitrile–water mixture, leaving the DCA extraction at (1), is distilled and recovered as the azeotropic mixture, which is then used for further desulfurization in (2). (6) Pure water can be separated from the sulfur compounds by sequential distillation, leaving the oxidized sulfur-containing compounds at the bottom of the still. As compared with the process proposed previously for the desulfurization of light oils in Chapter IV, the present process comprises relatively very simple stages. The boiling point of CCG (328–469.5 K) is different from the sublimation point of DCA (553 K), thus making possible the recovery of DCA by evaporation.

Experiments were carried out in which the CCG was mixed with the azeotropic mixture at the volume ratio of 1/3 and saturated with DCA. This was then photoirradiated for 48 h. Water was added to the resulting two-phase system and the CCG recovered by evaporation at 503 K. The CCG obtained from the top of the still (98%) contained no DCA and exhibited almost the same distillation temperature range as that for the feed CCG, as shown in **Table 5-1**. The research octane number for the CCG hardly decreased, following the desulfurization by the present process, as compared with

the feed CCG, whereas the decrease of 7–10 units was observed in hydrodesulfurization (Upson and Schnaith, 1997). These results therefore suggest that the present process is applicable for the selective desulfurization of CCG.

Summary

Desulfurization process, based on a visible light-induced electron-transfer oxidation using DCA and an organic two-phase extraction, has been applied to the desulfurization of catalytic-cracked gasoline (CCG), and the following results obtained.

(1) Sulfur-containing compounds (thiophenes, tetrahydrothiophene, thiol, and disulfide) dissolved in acetonitrile were photooxidized in the presence of DCA with irradiation at $\lambda > 400$ nm to form highly polarized compounds, which do not distribute into the nonpolar gasoline.

(2) When photooxidation was employed using DCA, desulfurization of the CCG was achieved, such that the sulfur content was reduced from 100 ppm to less than 30 ppm, with thiophene and C1-thiophenes being the most difficult compounds to be removed.

(3) The photooxidation of the sulfur-containing compounds proceeded with a good selectivity even in the presence of olefins. The research octane number for the CCG hardly decreased by desulfurization, suggesting that the present process is applicable for the selective desulfurization of CCG.

(4) DCA dissolved in the acetonitrile could be recovered by the addition of water, followed by further contact with CCG. The recovered DCA could be reused for further desulfurization. The overall desulfurization process, consisting of desulfurization and the recovery of DCA and solvents, was thus fully organized.

Chapter VI

Denitrogenation of Light Oils

by UV Irradiation and Liquid-Liquid Extraction

Introduction

In the previous chapters, desulfurization processes for light oils and catalytic-cracked gasoline have been studied, based on photochemical reaction and liquid-liquid extraction. These middle feedstocks contain a high proportion of nitrogen compounds as well as sulfur impurities. The nitrogen-containing compounds in light oils are known to be converted by combustion to nitrogen-oxides (NO_x), and hence to one of the main sources of acid rain and air pollution (Lee, 1991). The removal of nitrogen from light oils is reported to be rather more difficult than hydrodesulfurization (HDS) (Katzer and Sivasubramanian, 1979; Gutberlet and Bertolacini, 1984; Girgis and Gates, 1991). Thus the production of light oil, of both very low nitrogen and sulfur, requires inevitably rather severe operating conditions and the use of specially active catalysts.

The photodecomposition of the nitrogen-containing compounds is reported to proceed faster than that of the sulfur-containing compounds by sunlight irradiation in water (Mill et al., 1981). The denitrogenation of light oils may therefore be carried out simultaneously by the proposed desulfurization processes. In this chapter, aiming at development of the refining processes, which can remove both sulfur and nitrogen simultaneously, the photochemical denitrogenation of light oils has been investigated utilizing entire wavelength region of light. Two differing extraction systems, oil/water (Chapters I and II) and oil/acetonitrile (Chapter III, IV, and V), are employed for the denitrogenation studies. In order to clarify the photoreactivities and denitrogenation pathways for the nitrogen-containing compounds, a xylene solution containing pure nitrogen compounds is used as a model solution to represent the actual light oil, such that the proposed photochemical processes may then be applied to the denitrogenation of actual light oils. The denitrogenation efficiencies obtained by the present processes are compared with those for desulfurization, and the applicability of the processes as potential upgrading methods for light oils also studied.

Table 6-1. The Properties and Compositions of the Light Oils

		CLO	LGO	LCO
density @ 288 K	(g/mL)	0.8313	0.8548	0.8830
total sulfur	(wt%)	0.179	1.434	0.132
total nitrogen	(ppm)	80.4	160.0	243.1
basic nitrogen		0	0	54.7
neutral nitrogen		80.4	160.0	188.4
saturated hydrocarbon	(vol%)	76.2	75.4	33.7
aromatic hydrocarbon ^a	(vol%)			
monocyclic		19.5	14.9	36.4
bicyclic		4.3	9.7	29.9

^a Quantities of tricyclic aromatics and more than tricyclic aromatics are trace (< 1%).

Experimental Section

1. Materials

Aniline, indole, and carbazole were used to model the actual nitrogen-containing compounds in light oil. These compounds and other reagents, such as acetonitrile, xylene (*o*-, *p*-mixture), and hydrogen peroxide (30% aqueous solution), were supplied by Wako Pure Chemical Industries, Ltd. and were used as received. Three kind of light oils, commercial light oil (CLO; nitrogen content, 80 ppm), straight-run light gas oil (LGO; 160 ppm), and light cycle oil (LCO; 243 ppm) produced by fluid catalytic-cracking from vacuum gas oil, were used as feedstocks. The relevant properties of these materials, which have also been used for the previous desulfurization studies, are summarized in **Table 6-1**.

2. Apparatus and Procedure

The full procedure, concerning the desulfurization of light oils, has been described in the previous chapters and only a brief description is presented here. The light oils were mixed vigorously with distilled water or H₂O₂ aqueous solution at a volume ratio of 100/300 mL/mL, using a magnetic stirrer, and were photoirradiated by the immersion of a high-pressure mercury lamp (300 W, Eikohsha Co., Ltd., Osaka), combined with air bubbling at atmospheric pressure (**Figure 1-1**). The entire wavelength region of the light

was utilized. The model nitrogen-containing compounds (aniline, indole, or carbazole) were dissolved in xylene for the photoirradiation experiments. The extent of photoreaction obtained for the model nitrogen compounds was found to be little affected by the rate of air bubbling over the range 100–500 mL/min, and therefore a bubbling rate of 500 mL/min was adopted as standard in all runs. The light oil/acetonitrile two-phase mixtures were also photoirradiated, with vigorous mixing and air bubbling at differing volume ratios varying from 25/375 to 200/200 mL/mL and total solution volume of 400 mL. Homogeneous acetonitrile solutions (400 mL) containing the model nitrogen compounds, were also employed for the photoreaction studies.

3. Analysis

The concentrations of the nitrogen compounds in xylene were determined by gas chromatography (Shimadzu GC-14B, equipped with FID). The total nitrogen concentration in organic or aqueous solution was measured by a Total Nitrogen Analyzer (Mitsubishi Chemical Industry, TN-05). The individual nitrogen-containing compounds in the light oils were identified by the use of a GC-MS (JEOL JMS-DX303HF), employing an electron impact (EI) ionization (70 eV) method. Each of the identified compounds was analyzed quantitatively by a gas chromatography–atomic emission detector (GC-AED, Hewlett Packard 6890, equipped with AED G2350A), using an HP-1 column (i.d., 0.32 mm; film thickness, 0.17 μm ; length, 25 m), in accordance with the procedure of Quimby et al. (1998). The analytical conditions consisted of: sample volume, 2 μL ; split ratio, 1/10; oven temperature, 313–573 K (heating rate, 10 K/min); injection and detection temperatures, 553 K; transfer line, 583 K; carrier gas, He (makeup gas flow rate, 230 mL/min); inlet pressure, 11.8 psi; detection wavelength for nitrogen, 388 nm (cyanogen emission band); reagent gases, H_2 (40 psi), O_2 (80 psi), and CH_4 (50 psi). The NO_3^- anion concentration was analyzed by ion chromatography (Shimadzu LC-6A, equipped with conductivity detector CDD-6A), and IC-A1 column.

4. Fractionation of Basic and Neutral Nitrogen Compounds from Light Oils

The basic and neutral nitrogen compounds in the light oils were separated and concentrated according to the procedures of Dorbon et al. (1989) and Mao et al. (1995) with slight modification. The separation sequence was as follows: light oil (50 mL) was

dissolved in *n*-hexane (100 mL), and the solution contacted with 10% H₂SO₄ aqueous solution (50 mL × 3). The aqueous solution recovered was washed with dichloromethane (30 mL × 3), and the pH of the resulting solution adjusted to 12–13 by the addition of NaOH pellets. The basic nitrogen compounds regenerated were then recovered by extraction with dichloromethane (30 mL × 3). The light oil–hexane mixture recovered was fed to a column packed with a neutral aluminum oxide (20 g). The saturated and aromatic hydrocarbons were first eluted by dichloromethane/*n*-hexane (40/60, 100 mL), and the neutral nitrogen compounds then eluted by dichloromethane (150 mL). The polar compounds were finally eluted by methanol (100 mL). The basic and neutral nitrogen fractions obtained were concentrated by evaporation and analyzed by GC-AED and GC-MS, following their solution in dichloromethane.

Results and Discussion

1. Composition and Distribution of Nitrogen-Containing Compounds

The GC-AED and GC-MS analyses were carried out to acquire detailed information on the nitrogen-containing compounds in light oils. When the light oils were analyzed by GC-AED without any form of pretreatment, complicated chromatograms were obtained for all the oils, and thus the direct analysis of the nitrogen compounds was quite unsuccessful. This is because the nitrogen emission spectrum (388 nm) is interfered strongly by the C–H band emission (390 nm) of the aromatic hydrocarbons (Quimby et al., 1998). The nitrogen-containing compounds in the light oils were therefore concentrated and fractionated into their basic and neutral fractions, prior to the gas chromatographic analyses, by extraction and a following chromatographic separation. Only nitrogen compounds, at 98% recovery, were found to be contained in each fraction.

Figure 6-1 shows the nitrogen-specific GC-AED chromatograms for the neutral nitrogen fractions obtained from the light oils. The structures of the chromatograms for CLO and LGO closely resemble each other and each part of the peaks showed molecular ions at 181, 195, 209, and 213 (*m/z*), obtained by GC-MS analyses. These are thus attributable to C₁–C₄ alkyl-substituted carbazoles. In the chromatogram obtained for LCO, new peaks were seen to appear at lower retention times than for the alkyl

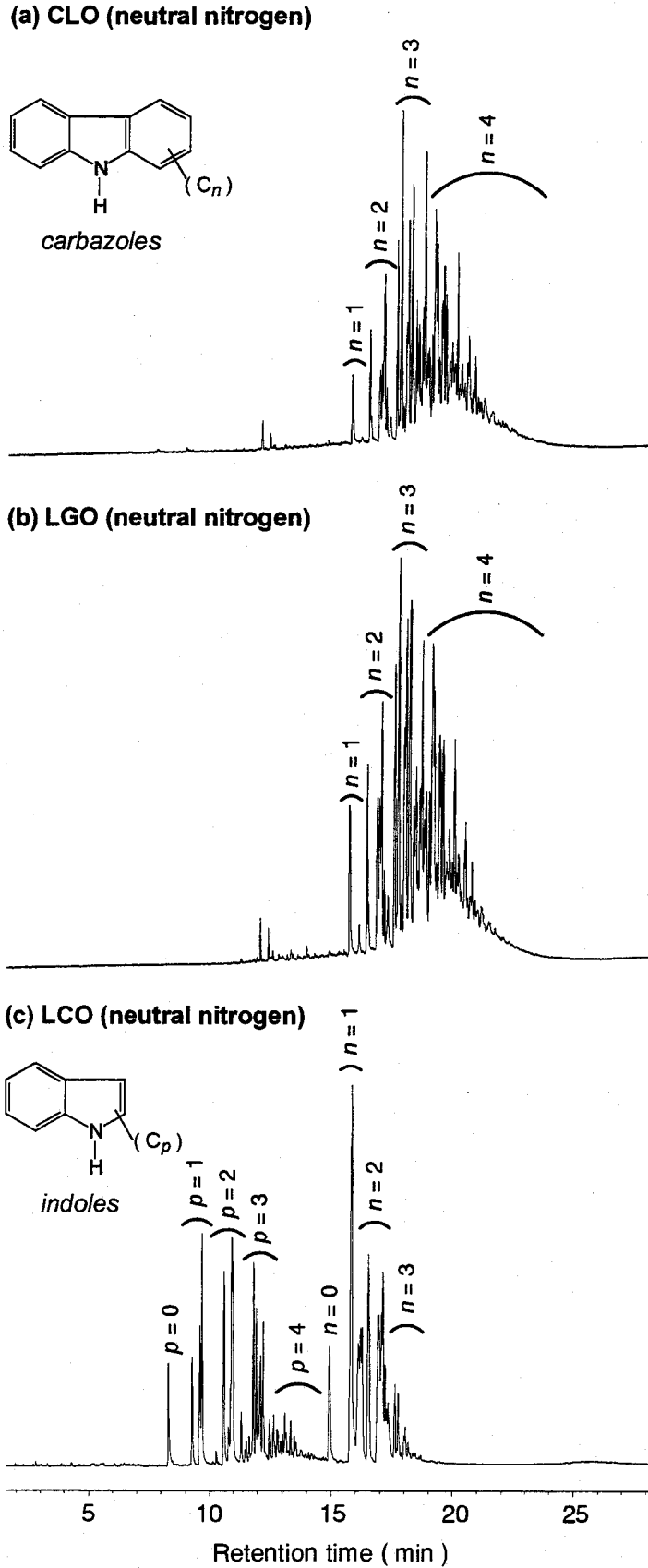

Figure 6-1. GC-AED chromatograms (nitrogen, 388 nm) for neutral nitrogen compounds fractionated from (a) CLO, (b) LGO, and (c) LCO.

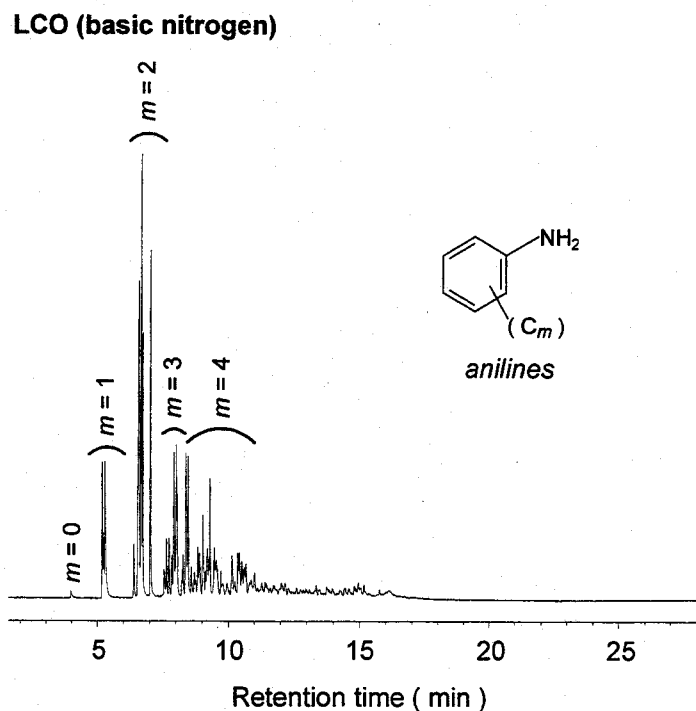

Figure 6-2. GC-AED chromatogram (nitrogen, 388 nm) for basic nitrogen compounds fractionated from LCO.

-substituted carbazoles. These peaks showed molecular ions at 117, 131, 145, 159, and 173 (m/z), and were therefore identified as indole and its C1–C4 alkyl-substituted derivatives.

Both the CLO and LGO contain scarcely any basic nitrogen compounds. **Figure 6-2** shows the nitrogen-specific GC-AED chromatogram for the basic nitrogen fraction obtained from LCO. These peaks showed molecular ions at 93, 107, 121, and 135 (m/z) according to GC-MS analysis. When the LCO sample was acetylated by acetic acid anhydride, all the peaks were seen to appear at higher retention times, as reported by Disanzo (1981). These results indicate that an amino function is involved in the molecular structure, thus revealing that these compounds are attributable to aniline and its C1–C4 alkyl-substituted derivatives. These results obtained for LCO accord well with those obtained by GC-NPD analysis, as reported by Dorbon et al. (1989).

The relative quantities of the individual nitrogen-containing compounds that were identified are summarized in **Tables 6-2, 6-3, and 6-4, column (a)**. Aniline, indole, and carbazoles were therefore used as the model representative nitrogen-containing compounds in light oils.

Table 6-2. Quantities of Carbazoles in (a) Feed Light Oils and in the Treated Oils, Following 36 h Photoirradiation to the Oil/Aqueous H₂O₂ Solution Two-Phase System, with: ([H₂O₂]_{initial} = (b) 0%, (c) 3%, and (d) 30%)

species	CLO (ppm)				LGO (ppm)				LCO (ppm)			
	(a)	(b)	(c)	(d)	(a)	(b)	(c)	(d)	(a)	(b)	(c)	(d)
carbazole									7.1	4.5	1.4	0
C1	1.2	0.2	0	0	5.2	1.8	0.3	0	40.2	37.1	28.1	10.1
C2	7.2	1.8	0.9	0	19.3	6.6	2.4	0	40.9	39.1	32.6	18.0
C3	29.6	7.7	4.1	1.1	58.1	30.9	18.3	4.1	11.6	11.2	10.1	8.1
C4	42.4	14.5	9.2	4.4	77.4	45.5	26.4	7.8				
total	80.4	24.2	14.2	5.5	160.0	84.8	48.8	11.9	99.8	91.9	72.2	36.2

Table 6-3. Quantities of Indoles in (a) Feed LCO and in the Treated Oils, Following 36 h Photoirradiation to the Oil/Hydrogen Peroxide Aqueous Solution Two-Phase System, with: ([H₂O₂]_{initial} = (b) 0%, (c) 3%, and (d) 30%)

species	LCO (ppm)			
	(a)	(b)	(c)	(d)
indole	3.2	0.2	0	0
C1	14.8	6.1	2.2	0
C2	28.1	20.0	11.0	2.2
C3	27.5	23.2	14.6	3.6
C4	15.0	14.6	10.1	6.7
total	88.6	64.1	37.7	12.5

Table 6-4. Quantities of Anilines in (a) Feed LCO and in the Treated Oils, Following 36 h Photoirradiation to the Oil/Hydrogen Peroxide Aqueous Solution Two-Phase System, with: ([H₂O₂]_{initial} = (b) 0%, (c) 3%, and (d) 30%)

species	LCO (ppm)			
	(a)	(b)	(c)	(d)
aniline	0.9	0	0	0
C1	8.1	4.8	0	0
C2	19.6	5.1	0.9	0
C3	7.5	5.2	2.1	0.2
C4	18.6	13.1	5.2	1.1
total	54.7	28.2	8.2	1.3

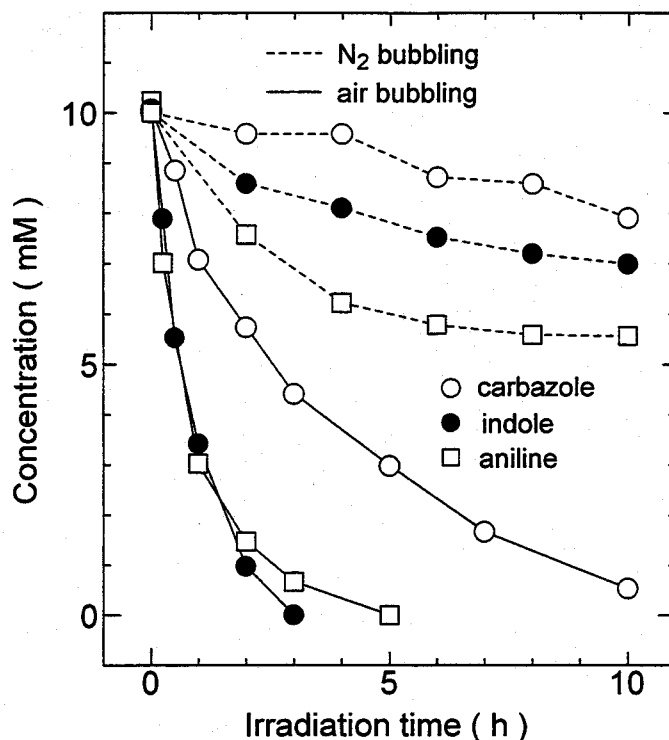

Figure 6-3. Time-course variation in the concentrations of the model nitrogen-containing compounds during photoirradiation of the xylene/water two-phase system under conditions of either air or nitrogen bubbling.

2. Denitrogenation Using an Oil/Water Two-Phase System

2.1. Model Nitrogen-Containing Compounds

Photochemical denitrogenation, based on an oil/water two-phase system, was first studied using a model light oil. The solubility of carbazole in saturated hydrocarbon solvents is very small (ca. 0.5 mM), and xylene was therefore used as diluting solvent. An initial concentration of 10 mM was adopted in all runs, corresponding to a nitrogen content of 120 ppm. **Figure 6-3** shows the time-course variation in the concentrations of carbazole, indole, and aniline in the xylene phase for the photoirradiation of the xylene/water two-phase system under conditions of both air and nitrogen bubbling. The photodecomposition of nitrogen-containing compounds was observed to be significantly slow, when nitrogen bubbled into the solution. The rate of photodecomposition was, however, much enhanced by air bubbling, thus indicating a significant effect of oxygen on the photodecomposition of the nitrogen compounds in xylene. Aniline and indole were seen to be photodecomposed rather faster than carbazole, thus demonstrating that carbazole is the most difficult compound to be denitrogenized.

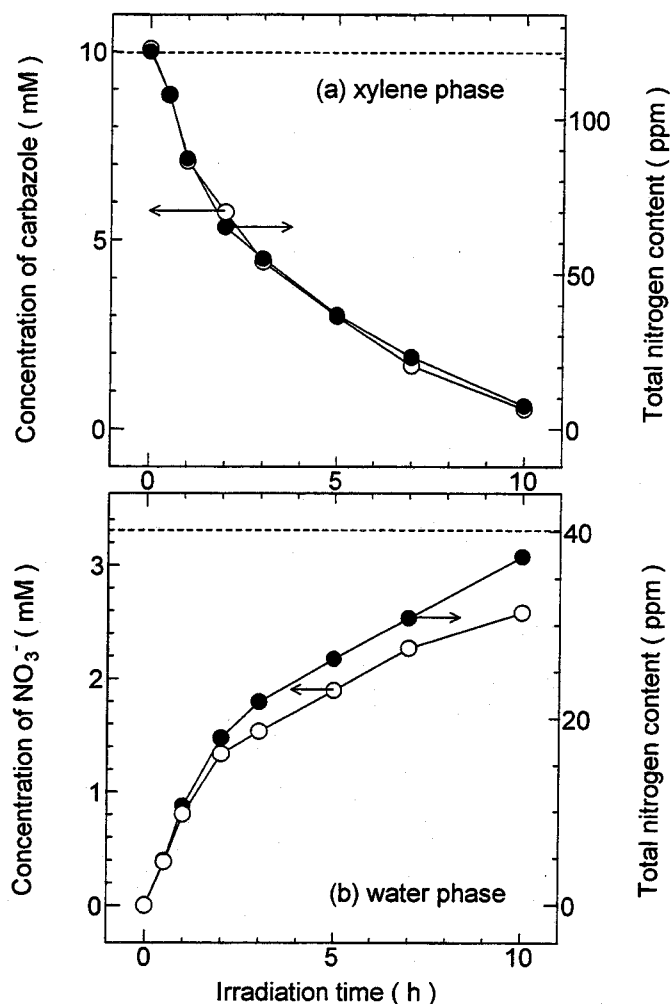

Figure 6-4. Time-course variation in (a) the concentrations of carbazole and total nitrogen in the xylene phase and (b) the concentrations of total nitrogen and NO₃⁻ ion in the water phase, during photoirradiation of the xylene([carbazole]_{initial} = 10 mM)/water two-phase system.

During photoirradiation of all the nitrogen compounds for the xylene/water two-phase system, no peaks containing a nitrogen atom were shown on the GC-AED chromatogram for the xylene phase, thus revealing that the removal of the photodecomposed nitrogen compounds into the water phase proceeds very fast. As shown in **Figure 6-4a**, the total nitrogen content, for carbazole, in the xylene phase decreases with increasing irradiation time, and at a reduction rate which accords almost exactly to that of the carbazole concentration. The total nitrogen content in the water phase increased accordingly, and the most of the nitrogen in the xylene was removed essentially into the water phase. Using ion chromatography analysis, all the nitrogen compounds removed into the water phase were found to appear as NO₃⁻ ion, and the corresponding increase in the NO₃⁻ concentration, as shown in **Figure 6-4b**, was seen to agree reasonably well with that of the

total nitrogen content in the water phase. The other nitrogen compounds, aniline and indole, were also found to be removed quantitatively into the water phase as NO_3^- ion.

2.2. Denitrogenation of Light Oils

Figure 6-5 shows the time-course variation in the total nitrogen content of the light oils, for the photoirradiation to the light oil/water two-phase system. The nitrogen content of all the light oils was seen to decrease rapidly at first, but then for the denitrogenation rates to become slower. The denitrogenation yields obtained following 36 h photoirradiation for the light oils were 70% for CLO, 48% for LGO, and 23% for LCO, respectively, thus revealing that LCO is the most difficult feedstock to be denitrogenized with the present process. As shown by **Tables 6-2, 6-3, and 6-4, column (b)**, following 36 h photoirradiation, the remaining quantities of the total anilines and indoles in the LCO decreased to 52% and 72% respectively, whereas as much as 92% of the carbazoles was found to remain. The low denitrogenation yield obtained for the LCO is therefore attributable to difficulty in the denitrogenation of the carbazoles.

Further study was therefore needed to clarify the cause for this low denitrogenation yield for the carbazoles from LCO. As shown in **Table 6-1**, LCO contains larger amount of the mono- and bicyclic aromatic hydrocarbons than CLO or LGO. The effect of the presence of aromatic hydrocarbons on the photodecomposition of the nitrogen-containing compounds was therefore studied. Tetralin and naphthalene were used as model compounds for the mono- and bicyclic aromatics. Various quantities of the model aromatics were added to the xylene solution, together with the nitrogen compounds, and then photoirradiated in the presence of water. **Figure 6-6** shows the variation in the denitrogenation yields, obtained for each nitrogen compound in the xylene phase, following 10 h photoirradiation. The photodecomposition for aniline and indole proceeded effectively even in the presence of both tetralin and naphthalene. The photodecomposition for carbazole, however, was suppressed significantly by the presence of naphthalene, and the denitrogenation yield decreased linearly with increasing naphthalene concentration. The results therefore strongly suggest that the presence of bicyclic aromatics is the cause of the low denitrogenation yield obtained for the carbazoles.

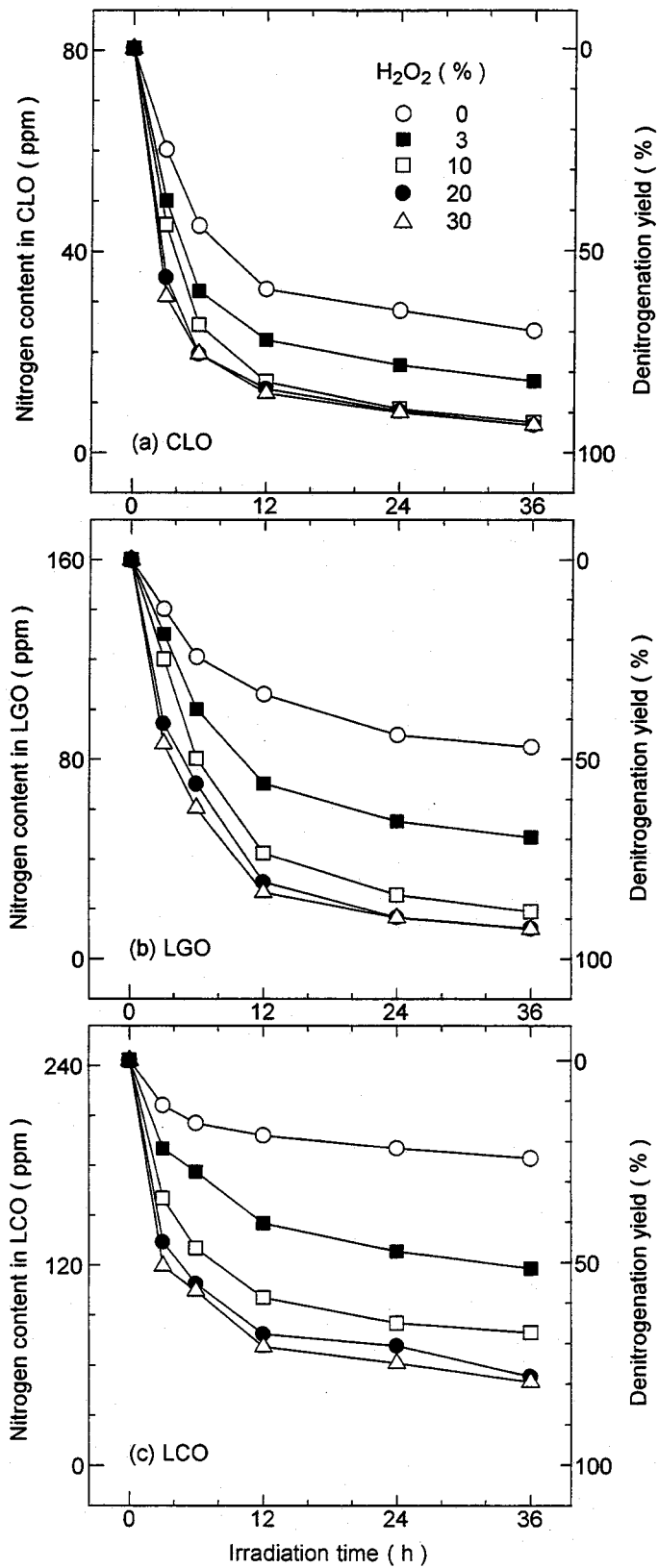

Figure 6-5. Time-course variation in the total nitrogen content of (a) CLO, (b) LGO, and (c) LCO, during photoirradiation of the light oil/water two-phase system, as a function of the H₂O₂ concentration in the water phase.

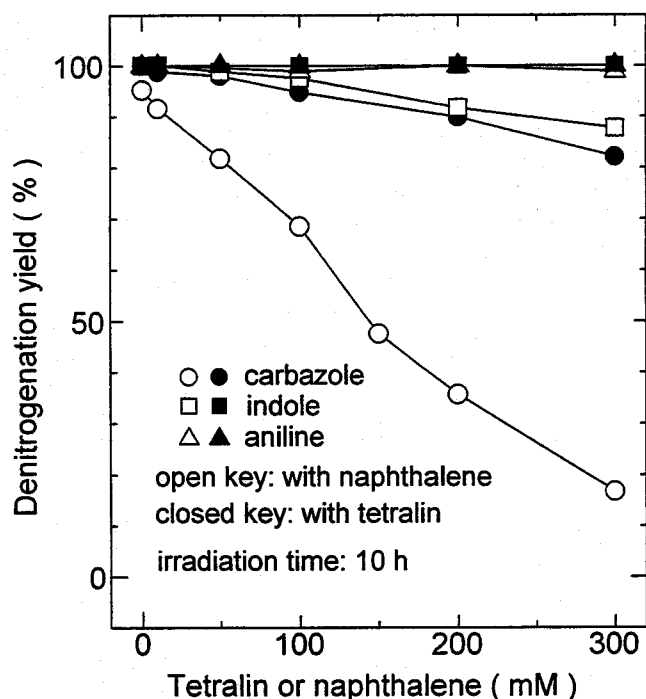
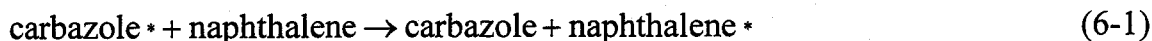

Figure 6-6. Effect of the addition of tetralin or naphthalene on the denitrogenation yields obtained for aniline, indole, and carbazole from a liquid xylene phase, following 10 h photoirradiation to the xylene([nitrogen compounds]_{initial} = 10 mM)/water two-phase system.

The photodecomposition of carbazole with molecular oxygen is reported to occur via its long-lived triplet excitation state (Picel et al., 1987). The triplet energy for naphthalene is estimated as 253 kJ/mol, which is lower than that for carbazole (294 kJ/mol) (Murov et al., 1993). The energy transfer from photoexcited carbazole to ground-state naphthalene, during the photoirradiation, thus occurs exothermically as:



This triplet energy transfer process may therefore result in the low photodecomposition yield for carbazoles, as reported by Picel et al. (1987) and Turro (1965). As shown in **Figure 6-5**, the denitrogenation yields for actual light oils is seen to decrease with a ranking order of CLO > LGO > LCO, which is also in accordance with the order of concentration of the bicyclic aromatics in the light oils shown in **Table 6-1**. Thus, in order to increase the denitrogenation yield for light oils, the photodecomposition rate for the carbazoles must therefore be enhanced. The adverse effect of naphthalene, noted in these studies, was also observed in previous desulfurization studies for dibenzothiophenes, as described in Chapters I and II.

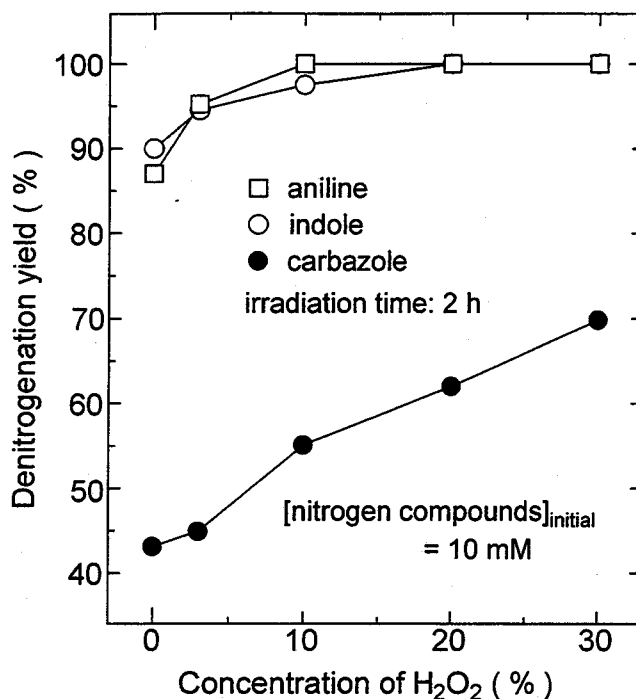

Figure 6-7. Effect of the addition of hydrogen peroxide, to the water phase, on the denitrogenation yield for the model nitrogen-containing compounds from the xylene phase, following photoirradiation (2 h) of the xylene/water two-phase system.

2.3. Effect of Hydrogen Peroxide on Denitrogenation

Hydrogen peroxide, as an oxidizing agent, has been added to the water phase, in previous desulfurization study for dibenzothiophenes from light oils (Chapter II) in order to accelerate the oxidation of the photoexcited dibenzothiophenes. The effect of H₂O₂ on the photodecomposition of nitrogen-containing compounds was therefore investigated. In this procedure, a xylene solution, containing each of the model nitrogen compounds, was photoirradiated, in the presence of aqueous H₂O₂ solution. The variation in denitrogenation yield, with respect to H₂O₂ concentration, is shown for each nitrogen compound in **Figure 6-7**. The denitrogenation rate was found to be accelerated by the addition of H₂O₂ for all the model nitrogen compounds with the rates increasing with increasing H₂O₂ concentration.

The addition of H₂O₂ may have two effects on the photodecomposition of the nitrogen-containing compounds. One is the effect of the hydroxyl radical produced by the direct photodecomposition of H₂O₂. The other is its effect as a weak oxidizing agent, which acts to oxidize the photoexcited nitrogen compounds before deactivation, as was

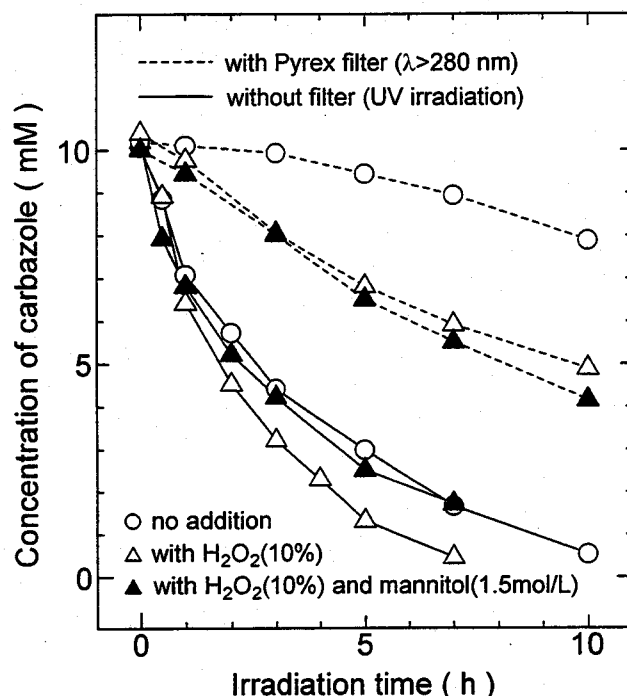
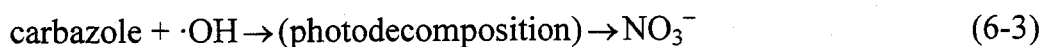

Figure 6-8. Effect of the addition of mannitol (1.5 mol/L) on the time-course variation in the concentration of carbazole in xylene, during photoirradiation of the xylene/water two-phase system, with and without the use of a Pyrex filter ($\lambda > 280$ nm).

found in the photooxidation of dibenzothiophene (Chapter II). In order to clarify the effect of H₂O₂, 1.5 mol/L mannitol, which is known as a hydroxyl radical scavenger (Murov et al., 1993), was added to the water phase together with H₂O₂ (10%, 1.3 mol/L), and this was photoirradiated with xylene solution containing carbazole. **Figure 6-8** shows the resulting time-course variation in the concentration of carbazole in the xylene phase. When irradiated with UV light (without Pyrex filter), the denitrogenation rate for carbazole with the addition of mannitol was decreased, and became comparable to that obtained for a zero addition of H₂O₂. This result indicates that dominant effect of H₂O₂ in the present system is as shown below.



The photodecomposition of the carbazoles and indoles has also been reported to proceed via a similar mechanism (Beer et al., 1954). When irradiated at wavelengths of $\lambda > 280$ nm (with Pyrex filter), at which the hydroxyl radical is not produced at all, the addition of H₂O₂ acts to accelerate the photodecomposition of carbazole. Under this condition, the

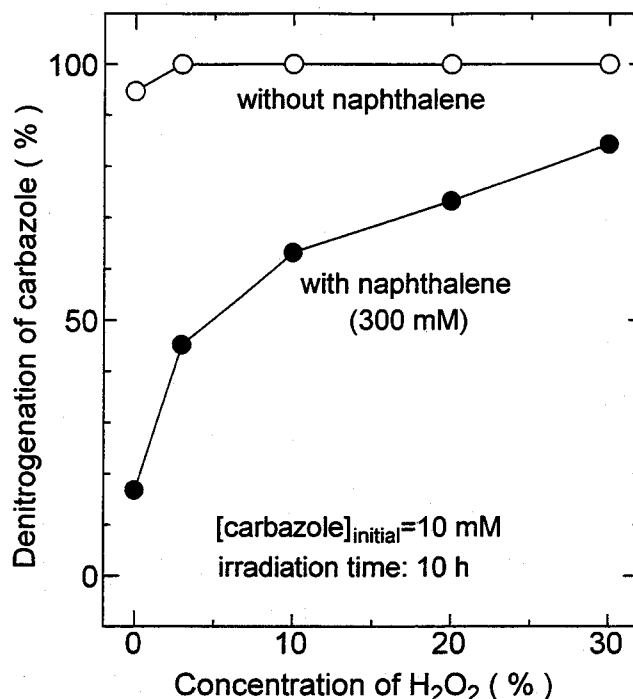

Figure 6-9. Effect of the addition of hydrogen peroxide on the percentage remaining carbazole, obtained both with and without the addition of naphthalene (300 mM), following 10 h photoirradiation of the xylene/water two-phase system.

addition of mannitol, of course, causes no decrease in the denitrogenation rate. These findings strongly suggest that H₂O₂ itself oxidizes the photoexcited carbazole, thus affecting the acceleration in the rate of photodecomposition, via:



These results show that the photodecomposition of carbazole is accelerated by both effects of H₂O₂, whereas the photodecomposition of dibenzothiophene is accelerated predominantly by the latter effect as weak oxidizing agent (Chapter II). The addition of H₂O₂ enhances the removal of carbazole from the xylene phase, even in the presence of naphthalene, as shown in **Figure 6-9**. The present process, when spiked with H₂O₂, is therefore effective for the denitrogenation of carbazole, even in the presence of double-ring aromatic hydrocarbons.

The denitrogenation for the actual light oils is also enhanced by the addition of H₂O₂, as shown in **Figure 6-5**. Denitrogenation is accelerated by an increase of up to 10% in the H₂O₂ concentration, but becomes almost saturated at higher concentration. The results show that in the present process, the total nitrogen concentration is decreased

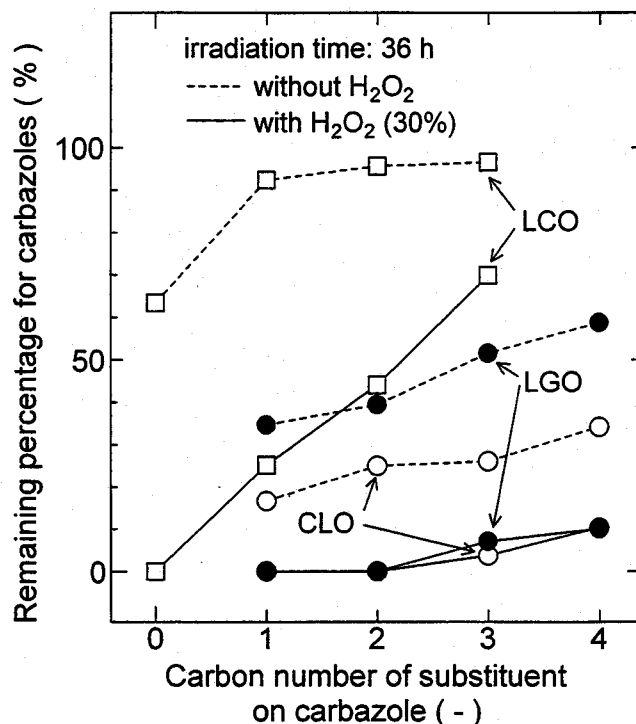

Figure 6-10. The remaining percentage for the carbazoles in the light oils, as a function of the carbon number of substituents on the carbazole, following 36 h photoirradiation, both with and without the addition of H₂O₂ (30%). The relative initial amount of each alkyl-substituted carbazole was set as 100%.

drastically from 80 to 5 ppm for CLO, from 160 to 12 ppm for LGO, and from 243 to 50 ppm for LCO, respectively, for conditions of 30% H₂O₂ concentration and 36 h photoirradiation. LCO was still found to be the most difficult feedstock to be denitrogenized in the present process. As shown in Tables 6-2, 6-3, and 6-4, column (d), although 98% anilines and 86% indoles were denitrogenized effectively, only 64% carbazoles denitrogenation was obtained. Figure 6-10 shows the remaining percentage for carbazoles in each of the three light oils, as a function of the carbon number of the substituent group on carbazole, following 36 h photoirradiation, both in the absence and in the presence of H₂O₂. The remaining percentage of carbazoles for all three light oils has a tendency to increase with increasing carbon number of the substituents. Thus, the highly-substituted carbazoles are the most difficult compounds to be denitrogenized in the present process.

2.4. Comparison with Desulfurization and Denitrogenation Abilities of the Process

The results, obtained both by the present and previous studies (Chapter II) show that

the present process, when using H_2O_2 as oxidizing agent, enables the simultaneous desulfurization and denitrogenation of light oils. The desulfurization and denitrogenation yields obtained for light oils, at 30% H_2O_2 concentration and 36 h photoirradiation, were 89 and 93% for CLO, 78 and 92% for LGO, and 70 and 80% for LCO, respectively (Chapter II), thus demonstrating that the present process is more effective for denitrogenation than for desulfurization. It has been established that the desulfurization of light oils, containing a high proportion of bicyclic aromatic hydrocarbons, is difficult and that highly-substituted dibenzothiophenes constitute the most difficult compounds (Chapter II). Thus, it is very important in the development of a more effective process to accelerate the removal of the highly-substituted dibenzothiophenes and carbazoles from aromatic rich light oil feedstocks.

3. Denitrogenation Using an Oil/Acetonitrile Two-Phase System

3.1. Extraction of Nitrogen-Containing Compounds from Light Oils

The distribution of the nitrogen-containing compounds from light oils to the acetonitrile was studied. It was found in a previous desulfurization study (Chapter III) that when LCO is contacted with acetonitrile, the resulting volume for the LCO is significantly smaller than that obtained for both CLO and LGO, because of the distribution of a high proportion of aromatic hydrocarbons from LCO to acetonitrile phase owing to their high polarity. The resulting volume of LCO, however, is increased by the addition of water to the acetonitrile phase. The LCO, after contact with acetonitrile, was therefore recovered completely, in the following experiments, by the addition of an equal volume of water as that of the feed acetonitrile to the two phases at a temperature of 303 K. This also accords with the procedure used in previous study concerning LCO desulfurization (Chapter III). The recovered light oils were, in principle, washed once with an equal volume of water, and the dissolution of acetonitrile into the resulting light oils was thereby suppressed completely.

Table 6-5 shows the variation obtained in the total nitrogen content of light oils following extraction into the acetonitrile, as a function of the feed acetonitrile/oil volume ratio. The quantity of the nitrogen compounds that were extracted was seen to increase, as expected, with an increase in the volume of acetonitrile. The extraction yield obtained

Table 6-5. Nitrogen, Sulfur, and Aromatic Contents of the Light Oils before and after Contact with Acetonitrile as a Function of Acetonitrile/Light Oil Volume Ratio

	CLO (ppm)			LGO (ppm)			LCO ^a (ppm)					
	acetonitrile/oil volume ratio			acetonitrile/oil volume ratio			acetonitrile/oil volume ratio					
	feed	1	3	7	feed	1	3	7	feed	1	10	15
saturated hydrocarbon (vol %)	76.2	79.2	82.0	85.4	75.4	79.6	81.9	85.8	33.7	35.2	37.4	39.5
monocyclic aromatics (vol %)	19.5	17.6	15.5	12.9	14.9	12.3	11.2	9.1	36.4	35.7	34.4	33.1
bicyclic aromatics (vol %)	4.3	3.2	2.5	1.7	9.7	8.1	6.9	5.1	29.9	29.1	28.2	27.4
total sulfur content (wt %)	0.179	0.164	0.132	0.105	1.434	1.182	0.932	0.735	0.132	0.131	0.127	0.102
total nitrogen content (ppm)	80.4	50.3	34.1	15.8	160.0	87.7	52.6	34.1	243.1	222.1	162.5	122.1

^aThe LCO, following extraction, was recovered by the addition of an equal volume of water as that of the feed acetonitrile.

Table 6-6. Quantities of Carbazoles in (a) Feed Light Oils and in the Treated Oils, (b) Following Simple Extraction (Light Oil/Acetonitrile volume ratio = 1/3) and (c) Following 10 h Photoirradiation

species	CLO (ppm)			LGO (ppm)			LCO (ppm)		
	(a)	(b)	(c)	(a)	(b)	(c)	(a)	(b)	(c)
carbazole							7.1	3.4	1.2
C1	1.2	0.2	0	5.2	0.9	0	40.2	35.1	29.2
C2	7.2	1.7	0.3	19.3	4.1	0.1	40.9	37.2	32.5
C3	29.6	12.2	3.1	58.1	19.6	3.0	11.6	10.5	8.4
C4	42.4	20.0	6.7	77.4	28.0	7.1			
total	80.4	34.1	10.1	160.0	52.6	10.2	99.8	86.2	71.6

Table 6-7. Quantities of Indoles in (a) Feed LCO and in the Treated Oils, (b) Following Simple Extraction (LCO/Acetonitrile volume ratio = 1/3) and (c) Following 10 h Photoirradiation

species	LCO (ppm)		
	(a)	(b)	(c)
indole	3.2	1.3	0.2
C1	14.8	7.1	3.8
C2	28.1	15.1	9.1
C3	27.5	20.1	14.2
C4	15.0	12.5	10.8
total	88.6	56.1	38.1

Table 6-8. Quantities of Anilines in (a) Feed LCO and in the Treated Oils, (b) Following Simple Extraction (LCO/Acetonitrile Volume Ratio = 1/3) and (c) Following 10 h Photoirradiation

species	LCO (ppm)		
	(a)	(b)	(c)
aniline	0.9	0.1	0
C1	8.1	1.2	0.4
C2	19.6	5.9	2.5
C3	7.5	3.5	1.8
C4	18.6	9.5	7.7
total	54.7	20.2	12.4

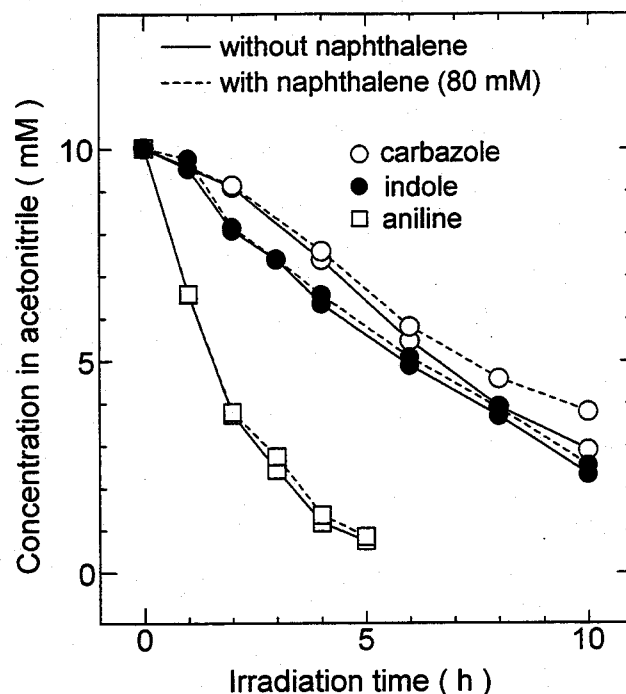

Figure 6-11. Time-course variation in the concentration of the nitrogen-containing compounds in acetonitrile, during photoirradiation, both with and without the addition of naphthalene (80 mM).

for the nitrogen-containing compound was greater than that for the sulfur-containing compounds, owing to the higher polarity (Dorbon et al., 1989). Thus, in the present process, the distribution of the nitrogen compounds from the light oil to acetonitrile proceeds just as effectively as for the sulfur compounds. The variations found in the composition of carbazoles, indoles, and anilines in the light oils, following extraction, are summarized in **Tables 6-6, 6-7, and 6-8, column (b)**, respectively. With LCO, the extraction yields for the anilines and indoles were larger than that obtained for carbazole, with a ranking order of anilines > indoles > carbazoles.

3.2. Photoreaction of Nitrogen-Containing Compounds in Acetonitrile

The three model nitrogen compounds were each dissolved in acetonitrile and then photoirradiated. **Figure 6-11** shows the time-course variation in the concentrations of the nitrogen-containing compounds in the acetonitrile. The concentrations of all the nitrogen compounds decreased with photoirradiation time, with carbazole being the most difficult compound to be photodecomposed, as was found also in the xylene/water two-phase system. The photodecomposition rate of indole obtained in acetonitrile is observed to be rather slower than that observed for indole in xylene solution and as shown

in **Figure 6-3**. This is because the indoles are stabilized in the polar solvent by the formation of an indole-solvent excited state complex (Hershberger et al., 1981). The photodecomposed products for all the model nitrogen compounds in acetonitrile were identified, by ion chromatography analysis, as NO_3^- ion, as was the case also for the xylene/water two-phase system, thus suggesting that these are highly polarized compounds, which do not distribute into the nonpolar light oil.

In the previous desulfurization studies (Chapter III), it was found that a large quantity of the aromatic hydrocarbons also distribute into the acetonitrile phase. Thus, the photoreactivities of the nitrogen compounds, in the presence of naphthalene, were also studied. These results are shown in **Figure 6-11** and show that no decrease in the photodecomposition rate for carbazole in acetonitrile was observed, even though the photodecomposition of carbazole in xylene was suppressed significantly by naphthalene, owing to the transfer of triplet energy from the excited-state carbazole to the ground-state naphthalene. This probably does not occur in acetonitrile because the highly polarized intermediates produced during the photodecomposition of carbazole are stabilized in the polar acetonitrile. Photodecomposition of the other nitrogen compounds, aniline and indole, in acetonitrile was also found to proceed in the presence of naphthalene. Thus, the nitrogen compounds, when distributed into the acetonitrile, may be photodecomposed effectively as well as sulfur compounds.

3.3. Denitrogenation of Light Oils

Mixtures of each light oil and acetonitrile were also photoirradiated. The time-course variation in the total nitrogen content for the light oils during photoirradiation is shown in **Figure 6-12**, as a function of feed acetonitrile/oil volume ratio. The data points corresponding to an irradiation time of zero are those obtained by mixing the two-phases and indicate the resulting equilibrium distribution concentration for the nitrogen compounds in the light oil phase. The nitrogen concentrations for all the light oils decreased slowly with respect to irradiation time. For example, taking a volume ratio of 7 following 10 h photoirradiation, the nitrogen contents for CLO were decreased from 80 to 2 ppm and for LGO from 160 to 1 ppm. The denitrogenation rate for LCO, under the above conditions, was rather slower than those for CLO and LGO. This effect was caused in this instance, since the addition of water, following the end of the

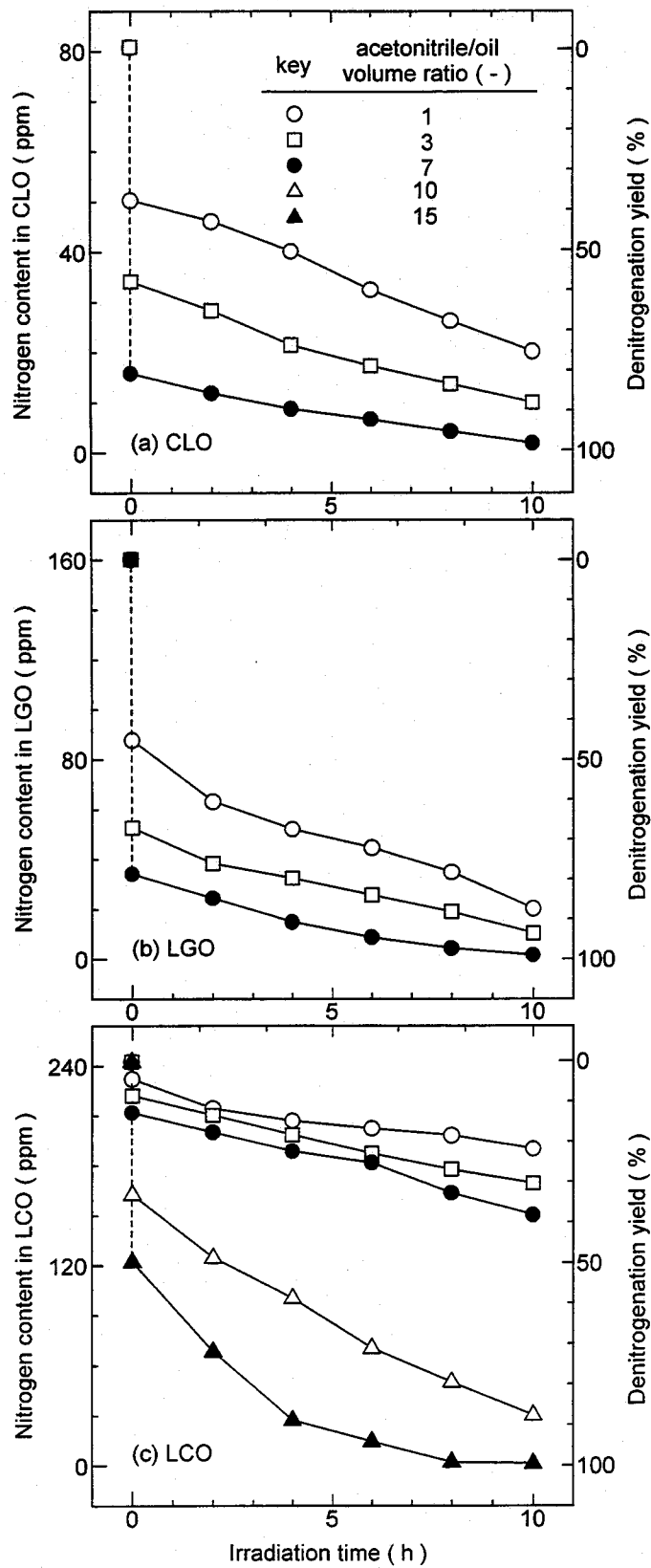

Figure 6-12. Time-course variation in the total nitrogen content for (a) CLO, (b) LGO, and (c) LCO, during photoirradiation of the oil/acetonitrile two-phase system, as a function of acetonitrile/oil volume ratio.

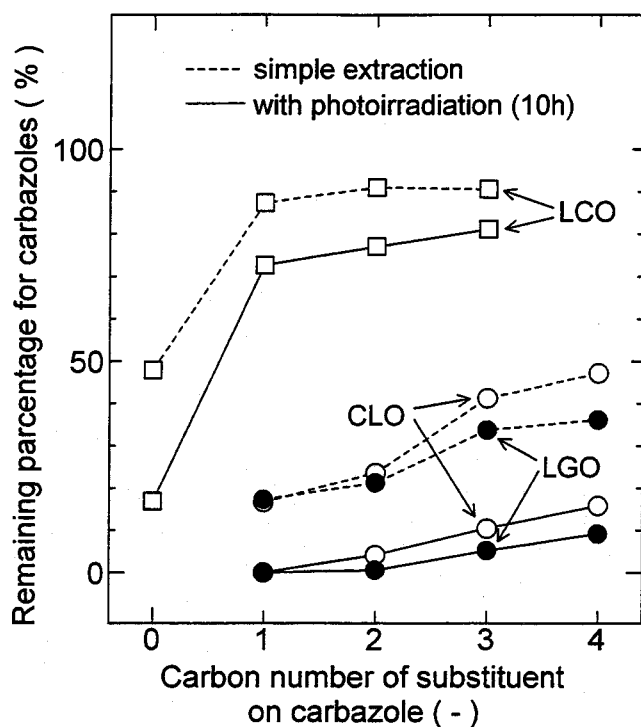

Figure 6-13. The remaining percentage for the carbazoles in light oils, following simple extraction and 10 h photoirradiation, as a function of the carbon number of substituents on the carbazole. The feed acetonitrile/light oils volume ratio was 7 for CLO and LGO, and 15 for LCO. The relative initial amount for each alkyl-substituted carbazole was set as 100%.

photoirradiation, decreased the distribution of the nitrogen compounds into the acetonitrile. The denitrogenation of the LCO was, however, substantially enhanced by further increase in the acetonitrile volume ratio. Thus, at a volume ratio of 15, the nitrogen content for LCO was decreased successfully from 243 to less than 2 ppm by 10 h photoirradiation. These results indicate that the nitrogen compounds, when distributed effectively into the acetonitrile, are photodecomposed efficiently, thus providing a successful removal of the nitrogen compounds from light oil to acetonitrile.

The variations obtained in the composition of the nitrogen-containing compounds in the light oils, following extraction and 10 h photoirradiation (acetonitrile/light oil volume ratio = 3), are shown in **Tables 6-6, 6-7, and 6-8**. For LCO, although the aniline and indole contents were decreased to 37% and 63% respectively by simple contact with acetonitrile, 87% of the carbazoles was found to remain. Following 10 h photoirradiation, the remaining percentage for the anilines and indoles decreased to 27% and 43% respectively, but as much as 71% of the carbazoles still remained in the resulting

LCO. Thus, carbazoles are still found to be the most difficult compounds to be denitrogenized in the present denitrogenation process, as was the case in the oil/water two-phase system.

In order to demonstrate the denitrogenation behavior of each alkyl-substituted carbazole, the remaining percentage of the carbazoles, following simple extraction (acetonitrile/oil volume ratio = 7 for CLO and LGO, and 15 for LCO) and 10 h photoirradiation, are shown in **Figure 6-13**, as a function of the carbon number of the substituent on the carbazole. The remaining percentage carbazoles for all these feedstocks, following simple extraction, tend to increase with increase in the carbon number of the alkyl substituents. This occurs since the polarity of the carbazoles is reduced by the substitution of the hydrophobic alkyl substituents. Under photoirradiation, this tendency is still observed for all feedstocks. These results therefore indicate that, in the present process, the highly substituted alkyl-carbazoles are the most difficult compounds to be denitrogenized, as was also the case in the oil/water two-phase system (Chapter III).

3.4. Comparison with Desulfurization and Denitrogenation Abilities of the Process

In comparison to the previous desulfurization studies (Chapter III), the present process is shown to carry out successfully the simultaneous removal of nitrogen and sulfur from light oils. It has been clearly demonstrated that the desulfurization of light oils, containing a high proportion of bicyclic aromatic hydrocarbons, becomes more difficult, and that highly-substituted dibenzothiophenes are the most difficult compounds to be desulfurized. For the further upgrading of light oils and a reduction in photoirradiation time, it is still important to accelerate the removal of highly-substituted dibenzothiophenes and carbazoles from light oils, as also in the studies of the oil/water two-phase system.

To clarify the denitrogenation and desulfurization ability of the present process, values for the nitrogen compound distribution, D_N , the ratio of the nitrogen concentration in acetonitrile phase and in light oil phase, were compared with the sulfur distribution ratio, D_S , where the data for D_S are cited from Chapter III. The D_N is defined as follows:

$$D_N = \frac{[\text{nitrogen}]_{\text{in acetonitrile}}}{[\text{nitrogen}]_{\text{in light oil}}} \quad (6-5)$$

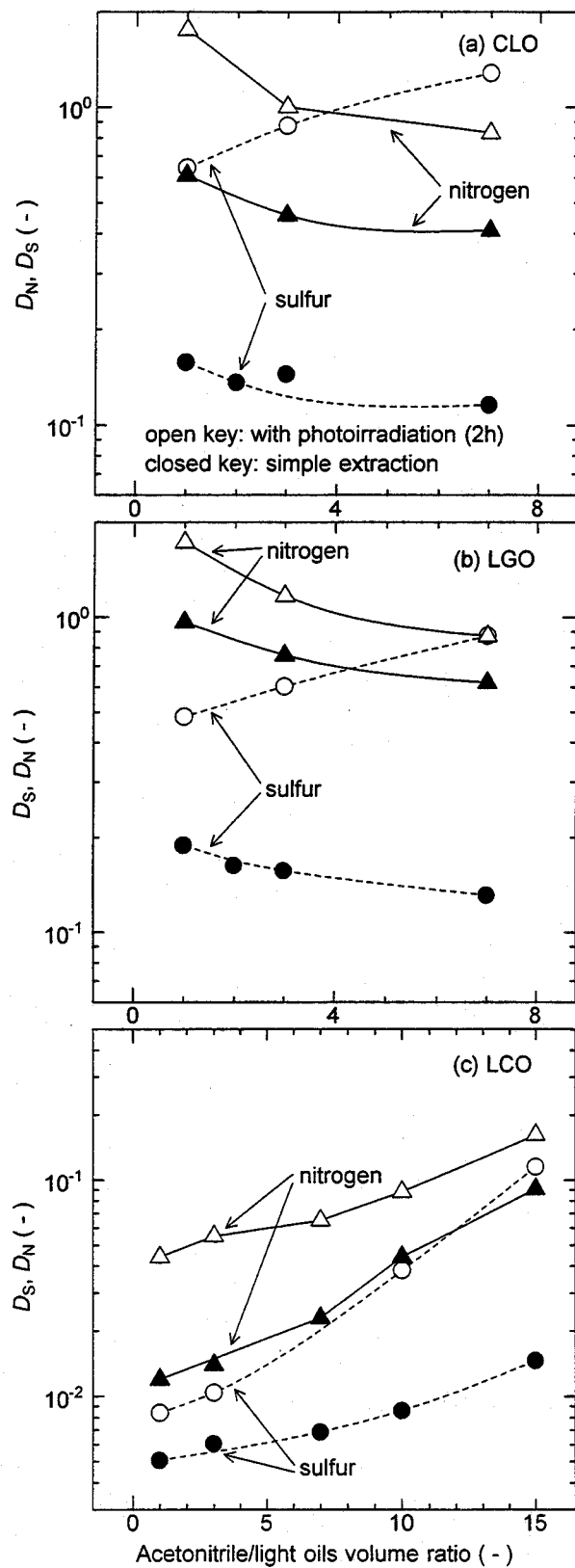

Figure 6-14. Effect of UV irradiation and extraction on the sulfur and nitrogen distribution ratio, D_S and D_N , in (a) CLO/acetonitrile, (b) LGO/acetonitrile, and (c) LCO/acetonitrile two-phase systems. D_S and D_N are the ratios of the concentration of sulfur and nitrogen compounds respectively in acetonitrile and in light oils.

The nitrogen content in the acetonitrile phase was determined from the nitrogen quantity removed from the light oil phase, since the direct analysis of the nitrogen content of acetonitrile phase includes both the nitrogen of the transferred nitrogen species from the light oil and of the acetonitrile itself. The results obtained are shown in **Figure 6-14**. For all light oils, the values for D_N , obtained by simple extraction, are rather larger than those for D_S , as would be expected. The values for D_S for all light oils are increased by 2 h photoirradiation. Also the difference between the values for D_S , both with and without photoirradiation, is increased by increasing acetonitrile/oil volume ratio.

Although the values for D_N are also increased by photoirradiation, the increase is less than that for D_S , and the difference of the values for D_N , with and without photoirradiation, decreases by increasing acetonitrile/oil volume ratio. Since the concentration of nitrogen compounds in the acetonitrile is decreased with increasing acetonitrile/oil volume ratio, the quantity of the nitrogen compounds photodecomposed is shown to be decreased accordingly. This may, therefore, result in the low increase in the values for D_N obtained under photoirradiation. The nitrogen compounds are extracted more easily than sulfur compounds into the acetonitrile phase from the light oils, but the photodecomposition efficiency for the nitrogen compounds in acetonitrile is slightly less than that for the sulfur compounds. The values for D_N and D_S for LCO are rather lower than those for CLO and LGO, as shown in **Figure 6-14**, since in the denitrogenation and desulfurization for LCO, water addition is required to enhance the recovery of LCO after the photoreaction. The present process may thus be most effective for light oils having high nitrogen but low aromatic content.

The overall desulfurization process involving the recovery of acetonitrile has been fully developed in a previous desulfurization study (Chapter III). In this process, the acetonitrile dissolved into the light oil was recovered by washing with water and then regenerated by distillation as an azeotropic mixture (acetonitrile/water, 84/16 v/v (bp 350 K)), which can be reused for further desulfurization. The effect of water on the denitrogenation of light oils was therefore investigated, with the results obtained, shown in **Figure 6-15**. Although the denitrogenation yields for all light oils, following 10 h photoirradiation, are decreased by an increase in the water concentration in acetonitrile, the yields are found to be reduced successfully to less than 5% of the feed concentration,

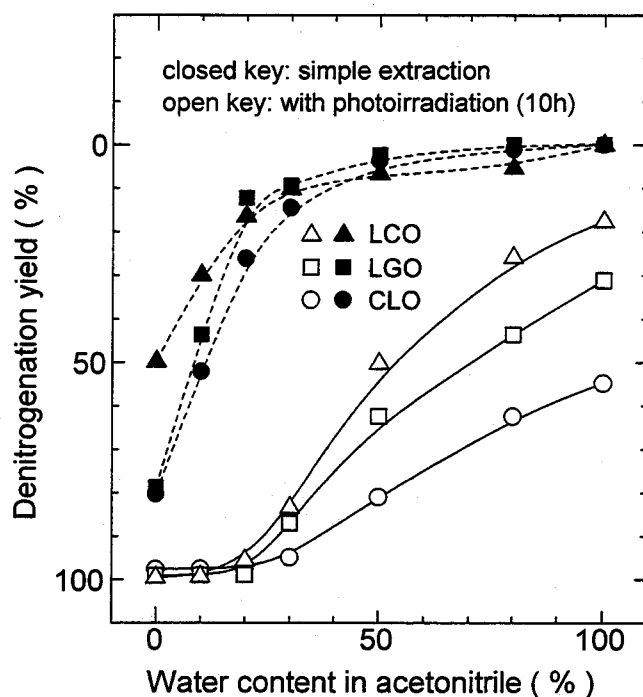

Figure 6-15. Effect of the addition of water on the denitrogenation yield for the light oils following simple extraction and 10 h photoirradiation. The acetonitrile/light oils volume ratio was 7 for CLO and LGO, and 15 for LCO.

for water concentrations in the range 0–20%. The present process, thus, seems to be practicable for the denitrogenation of light oils in the presence of 0–20% of water/acetonitrile solution and the results suggest that a recovered acetonitrile azeotrope mixture (containing 16% water) can be reused for further denitrogenation and desulfurization, as proposed in Chapter III, for the case of desulfurization.

Summary

Photochemical denitrogenation process for light oils, effected by a combination of UV irradiation and liquid–liquid extraction, has been investigated, and the following results obtained.

1) Photochemical denitrogenation using an oil/water two-phase system was first studied. Aniline, indole, and carbazole, when dissolved in xylene, were photodecomposed by UV irradiation, and the resulting NO_3^- ion was removed successively into the water phase. The photodecomposition of carbazoles in light oils

was, however, strongly suppressed by triplet energy transfer from photoexcited carbazole to ground-state bicyclic aromatic hydrocarbons.

2) The photodecomposition of carbazole, under the above conditions, was enhanced by the addition of hydrogen peroxide to the water phase. The denitrogenation of the light oil was thereby much enhanced, and the nitrogen content for all light oils was decreased to less than 20% of the feed concentration. A simultaneous removal of both sulfur and nitrogen was therefore effected by the present process, in which the denitrogenation proceeded more effectively than desulfurization.

3) A photochemical denitrogenation process, based on an oil/acetonitrile two-phase system, was then studied. In this case, the nitrogen-containing compounds in the light oils were extracted into the acetonitrile phase, and were there photodecomposed to form NO_3^- ion. The successful removal of the nitrogen-containing compounds from light oils to acetonitrile was thereby carried out, and the nitrogen contents for all the light oils were decreased successfully to less than 3% of the feed concentration.

4) The present process, using an oil/acetonitrile system, enabled the simultaneous removal of both sulfur and nitrogen from light oils. Nitrogen compounds were extracted more easily into the acetonitrile phase than the sulfur compounds, but the photodecomposition efficiency for the nitrogen compounds in acetonitrile was slightly less than that for sulfur. The closed process proposed for the desulfurization of light oils in Chapter III is applicable also to the denitrogenation of light oils, and the acetonitrile used in the present process can be reused for further desulfurization and denitrogenation.

Chapter VII

Demetalation of Petroleum Residues

by UV Irradiation and Liquid–Liquid Extraction

Introduction

In the previous chapters, photochemical desulfurization and denitrogenation processes for light oil feedstocks, using liquid–liquid extraction techniques, have been investigated. Owing to the continuous depletion of petroleum resources and the consequent increase in oil prices, the use of heavy residual feedstocks, containing heavier components than light oils, is becoming increasingly more attractive as a precursor for catalytic-cracked gasoline and light oil. Petroleum residue, produced during the atmospheric and vacuum distillation of crude oil, contains a high content of sulfur, nitrogen, and the heavy metals. Vanadium and nickel are most concentrated in residue oils and are known to occur naturally as vanadyl(IV) and nickel(II)porphyrins (Yen et al., 1969). The demetalation of metalloporphyrins is rather difficult than desulfurization and denitrogenation by the current hydrotreating processes, and leaves a metal sulfide deposit on the catalyst during the reaction. This causes a corresponding loss in catalyst activity (Tsai et al., 1991; Chen and Massoth, 1988; Chen and Hsu, 1997), and the catalyst regeneration and/or replacement must therefore be carried out. The demand for light fractions as motor fuels is expected to increase steadily, and the upgrading of heavy residual feedstocks will certainly be increased very significantly in the near future.

The photochemical and photophysical properties of metalloporphyrins have been studied extensively owing to the importance of the porphyrin ring system in photosynthetic processes and in biological systems. Magnesium(II)protoporphyrin, when dissolved in benzene, is reported to be oxidized by photoirradiation in the presence of molecular oxygen to form a demetalized protobiliviolin, via hydrogenation followed by oxidation of the porphyrin ring (Barrett, 1967). Zinc(II)tetraphenylporphyrin, dissolved in benzene, is reported to be photodecomposed by sunlight irradiation in the presence of benzoin as a reducing agent to form a free-base tetraphenylporphyrin (Seely, 1955). Also Jones et al. (1994) reported recently that vanadyl(IV)tetraphenylporphyrin is

photodecomposed in the gas phase by the irradiation of 266 nm ionizing laser to cause the loss of the central vanadyl ion. Considering these photochemical behaviors of the metalloporphyrins, photochemical technique may be applicable to the demetalation of vanadium and nickel from residue oils.

In this chapter, photochemical demetalation process for vanadyl and nickelporphyrins from residue oils is studied as an extension to the desulfurization and denitrogenation studies. A simultaneous photoreaction and extraction process is first studied using an oil/water two-phase system, as in Chapter I, II, and VI. In order to know the chemistry of metalloporphyrins, tetralin solutions containing the pure metalloporphyrins are used as model solutions representing the residue oils. The proposed process is then applied to the demetalation of actual residue oils, and the feasibility of the process studied in detail by further experiments. The nature of the process is clarified by ESR studies showing that the metalloporphyrins in the residue oils are associated strongly with the asphaltenic molecules to form "bound" type metalloporphyrins. In order to weaken this association and to convert "bound" type metalloporphyrins to the "free" type, a novel photoreaction with succeeding extraction process is employed, and the applicability of this new process for residue oil of high molecular weight and high metal concentration is studied. The overall process, involving also the recovery of solvents, is then formulated as an energy-saving and safety demetalation process for heavy residual feedstocks.

Experimental Section

1. Materials

Vanadyl(IV)tetraphenylporphyrin (VOTPP) and nickel(II)tetraphenylporphyrin (NiTPP) purchased from Aldrich Chemical Company were used as model compounds for the metalloporphyrins contained in residue oil (Chen and Massoth, 1988; Kameyama et al., 1981). These metalloporphyrins purchased are reported to contain some metallochlorin impurities, having the structure that pyrrole ring on the parent metalloporphyrins is dihydrogenated. These impurities exhibit absorption band at 632 nm (vanadyl(IV)tetraphenylchlorin) and 618 nm (nickel(II)tetraphenylchlorin), respectively (Hung and Wei, 1980). Vanadyl(IV)octaethylporphyrin (VOOEP) and nickel(II)-

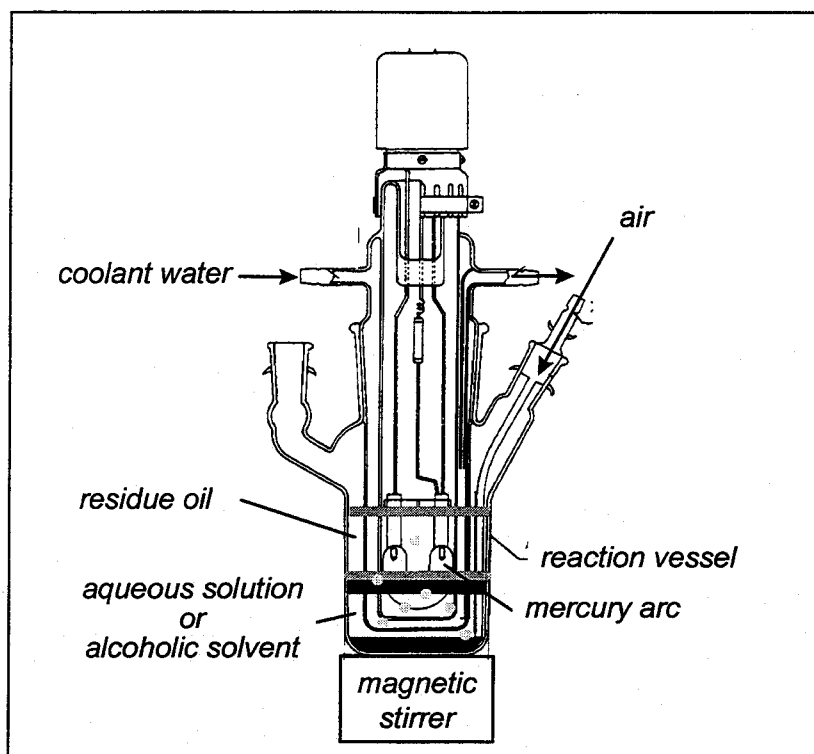

Figure 7-1. Schematic representation of the experimental photoreactor (high-pressure mercury lamp, 100 W). Capacity, 400 mL.

octaethylporphyrin (NiOEP) were prepared by refluxing vanadyl sulfate dihydrate or nickel dichloride (Wako) with free-base OEP (Aldrich) in accordance with the procedure of Bonnet et al. (1978). Vanadyl(IV)etioporphyrin (VOETIO) and nickel(II)etioporphyrin (NiETIO) were synthesized from free-base ETIO (Aldrich) according to the method of Erdman et al. (1956). These materials, following the purification by flash chromatography using silicagel packing and dichloromethane/methanol (80/20 v/v) as eluent, were also used as model compounds. Tetralin (tetrahydronaphthalene), decalin (decahydronaphthalene, *cis*-, *trans*-mixture), and other chemicals (Wako) were used without further purification. Atmospheric residue (AR) and vacuum residue (VR) supplied from Cosmo Petroleum Institute were used as feedstocks for this study. The properties of these residue oils are summarized in **Table 7-1**.

2. Apparatus and Procedure

The tetralin solution containing VOTPP or NiTPP was mixed vigorously with either aqueous solution or alcoholic solvent by magnetic stirrer at volume ratios of 50/100 or 100/50 mL/mL, respectively. These solutions were photoirradiated by the immersion of a high-pressure mercury lamp (100 W, Eikohsha Co., Ltd., Osaka), as shown in **Figure 7-**

Table 7-1. Properties of Atmospheric Residue (AR) and Vacuum Residue (VR), and Their Maltenic and Asphaltenic Fractions Obtained by Solvent Deasphalting Using *n*-Hexane

	atmospheric residue (AR)		vacuum residue (VR)	
	feed	following demetalation ^a	feed	following demetalation ^a
density @ 288 K (g/mL)	0.9929	0.9902	1.0306	1.0189
viscosity @ 323 K ($\times 10^5$ mm ² /s)	0.82	0.80	1.60	1.57
vanadium (ppm)	118.0	2.4	162.0	44.4
nickel (ppm)	39.0	0.4	49.1	6.1
sulfur (wt%)	4.19	4.03	4.69	4.30
nitrogen (wt%)	1.35	0.88	1.80	1.20
.....				
maltenic fraction (hexane soluble)				
yield (%)	86.3	—	85.9	—
vanadium (ppm)	60.0	<0.1	76.4	<0.1
nickel (ppm)	15.1	<0.1	25.6	<0.1
sulfur (wt%)	2.90	2.34	3.12	2.46
nitrogen (wt%)	0.78	0.51	0.89	0.56
.....				
asphaltenic fraction (hexane insoluble)				
yield (%)	13.7	—	14.1	—
vanadium (ppm)	472	110.9	688	295.8
nickel (ppm)	144	31.5	192	31.4
sulfur (wt%)	12.32	11.89	14.30	13.70
nitrogen (wt%)	4.94	4.67	7.34	6.96

^a Irradiation time: 36 h.

1, and combined with air bubbling at atmospheric pressure. The AR and VR were each dissolved in tetralin/decalin (1/1 v/v) mixture to ensure fluidity for the photoreaction studies. The extent of photoreaction for the VOTPP was found to be little affected by the air bubbling in the range 100–1000 mL/min, and therefore a bubbling rate of 500 mL/min was adopted as standard. The temperature of the solutions, during photoirradiation, was about 303 K. An emulsion formed, when contacting residue oil with aqueous solution, was demulsified electrically, following photoirradiation and according to the procedure of Taylor (1988). Solvent deasphalting for the AR and VR was carried out according to the following procedure (Ono, 1971). In this, a fivefold volume of *n*-hexane was added to the residue oil, and were shaken for 8 h and left for 24 h. The asphaltenic fraction (hexane-insoluble) and maltenic fraction (hexane-soluble) were recovered by filtration and dried under vacuum. The properties of the respective fractions are summarized in Table 7-1.

3. Analysis

Absorption spectra were measured by a UV-visible spectrophotometer (Hewlett Packard HP8452A). IR spectra were measured using a FT/IR-610 infrared spectrophotometer (Jusco Corporation) on KBr disks. The ESR spectra were recorded at X-band using a Bruker ESP 300 spectrometer with 100 kHz magnetic field modulation at room temperature, and were calibrated using a 1,1'-diphenyl-2-picrylhydrazyl (DPPH) as standard. The concentration of tetravalent(IV) vanadium both in tetralin and in aqueous solution was measured by ESR and according to the procedure of Saraceno et al. (1961). The concentration of vanadyl and nickelporphyrins in tetralin was analyzed by reverse-phase HPLC (Shimadzu LC-6A, equipped with a spectrophotometric detector SPD-6A). The separations were performed in a 150 × 4.6 mm² i.d. Shim-pack column (Shimadzu HRC-ODS), using acetonitrile/water (80/20 v/v) isocratic elution with a flow rate of 1.5 mL/min. The corresponding peaks were detected at wavelengths of maximum absorption of the solet bands for each metalloporphyrin in tetralin (VOTPP, 424 nm; VOOEP, 410 nm; VOETIO, 409 nm; NiTPP, 416 nm; NiOEP, 396 nm; NiETIO, 394 nm). Gel permeation chromatograms for the molecular weight distribution of the oils were obtained using a LC-08 instrument (Japan Analytical Industry) and were calibrated by the

use of a polystyrene. The total vanadium and nickel concentrations in organic or aqueous solution were measured by an inductively coupled argon plasma atomic emission spectrophotometer (Nippon Jarrell-Ash ICAP-575 Mark II), using tetralin or water as carrier solvent. The concentrations of the VO_3^- anion were analyzed by ion chromatography (Shimadzu LC-6A, equipped with conductivity detector CDD-6A, and with IC-AI column).

Results and Discussion

1. Demetalation Process Consisting of Simultaneous Photoreaction and Liquid-Liquid Extraction

1.1 Demetalation of Vanadylporphyrin from Tetralin

In order to examine the photoreactivity of vanadyl(IV)tetraphenylporphyrin (VOTPP), the tetralin solution containing VOTPP was photoirradiated under air bubbling in the absence of aqueous phase. Practically no decrease in the VOTPP concentration was observed for irradiation at wavelengths for $\lambda > 400$ nm. Although Jeoung et al. (1998) have reported that VOTPP in solution is photoexcited by the irradiation at wavelengths for $\lambda > 427$ nm, this is insufficient to cause photodecomposition of the VOTPP in tetralin. For irradiation at wavelengths for $\lambda < 400$ nm, however, the VOTPP concentration was observed to decrease gradually with increasing irradiation time, but the photodecomposition rate was enhanced remarkably for wavelength of $\lambda < 300$ nm. Photoirradiation by short-wavelength UV light is therefore effective for the photodecomposition of VOTPP. When the tetralin solution photoirradiated was left for just 2 days, a black precipitate of water-soluble vanadium compounds was formed.

The tetralin solution containing VOTPP was mixed with distilled water, and was photoirradiated with vigorous stirring. The initial VOTPP concentration (2 mM) used corresponds to a vanadium content of 110 ppm. **Figure 7-2** shows the time-course variations in the concentration of VOTPP and also in the total vanadium contents of the tetralin and water phases under conditions of bubbling with different gases. With air or O_2 bubbling, the VOTPP concentration and the total vanadium content in tetralin decreased successfully by irradiation time. The total vanadium concentration in the

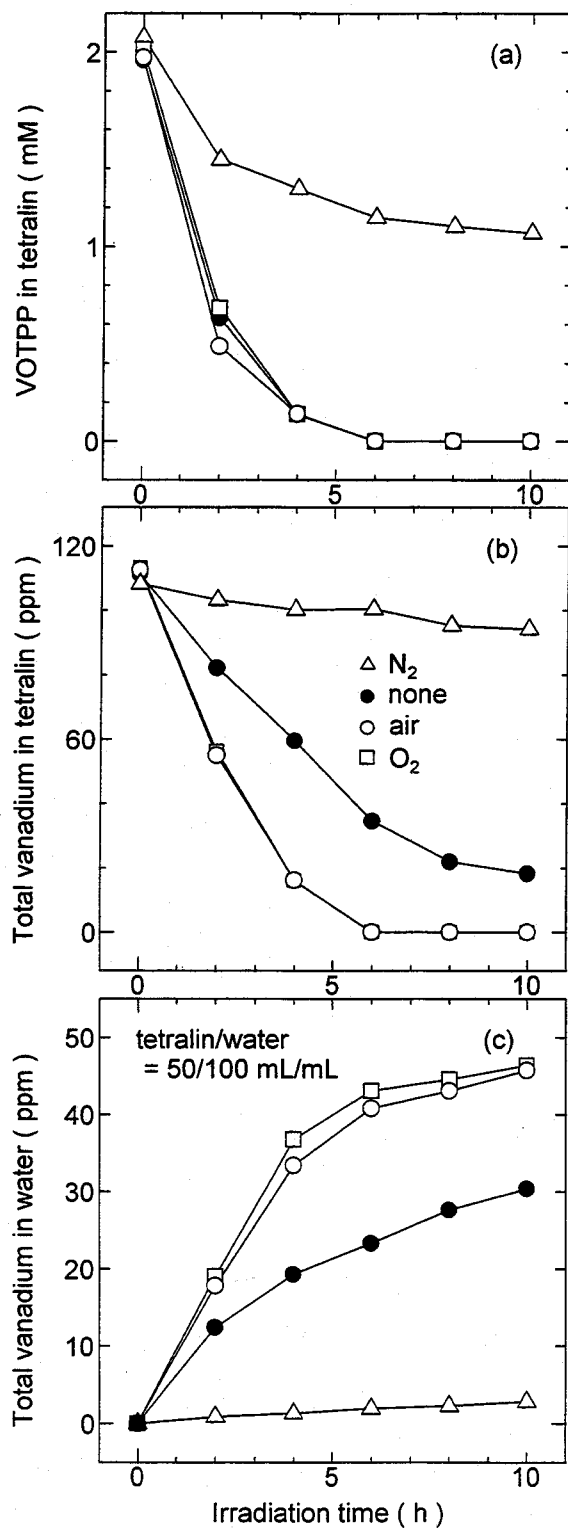

Figure 7-2. Time-course variation in the concentrations of (a) VOTPP, (b) total vanadium in the tetralin phase, and (c) total vanadium in the water phase, during photoirradiation to the tetralin ($[VOTPP]_{\text{initial}} = 2$ mM)/water two-phase system, under bubbling by different gases.

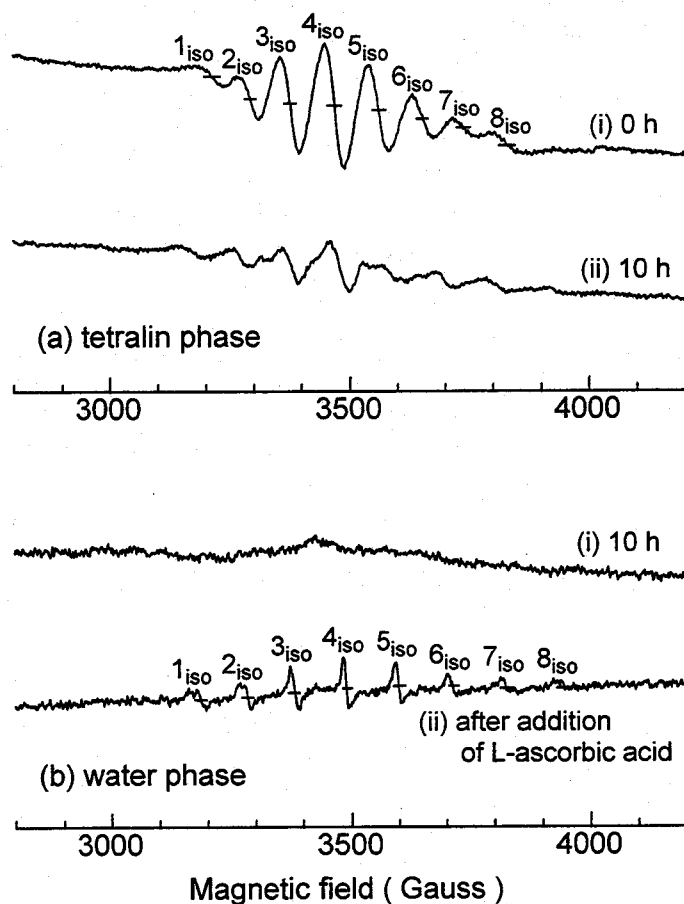

Figure 7-3. ESR spectra for the tetralin phase obtained by (a-i) 0 h and (a-ii) 10 h photoirradiation to the tetralin ($[VOTPP]_{\text{initial}} = 2 \text{ mM}$)/water two-phase system, and spectra for the water phase (b-i) following 10 h photoirradiation and (b-ii) following the addition of aqueous 1 mol/L L-ascorbic acid solution to the sample (b-i).

water phase increased correspondingly, and essentially most of the vanadium was removed into the water phase. However, for bubbling of nitrogen gas, the resulting photodecomposition of the VOTPP was significantly suppressed. Thus, oxygen appears to have a significant effect on the photodecomposition of VOTPP.

1.2 Demetalation Mechanism of Vanadylporphyrin

Since the divalent(II) or tetravalent(IV) vanadium has a single electron in its d -orbital, the 8 line isotropic hyperfine splitting may be determined by ESR measurement (Selbin, 1965). **Figure 7-3a** shows ESR spectra for tetralin solution, following 0 and 10 h photoirradiation of the tetralin (containing VOTPP(IV))/water two-phase system. The isotropic 8 line signals, which were well observed in tetralin for zero photoirradiation time decreased with increasing irradiation time, such that they disappeared after 10 h, as shown

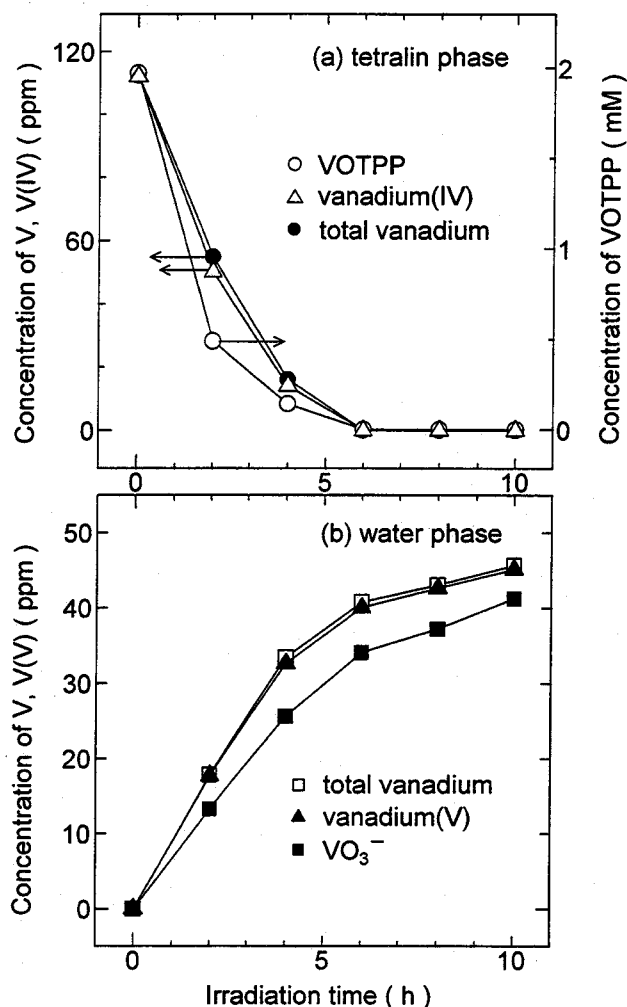

Figure 7-4. Time-course variation in (a) the concentrations of VOTPP, tetravalent(IV) vanadium, and total vanadium in the tetralin phase, and (b) the concentrations of pentavalent(V) vanadium, total vanadium, and VO_3^- ion in the water phase, during photoirradiation to the tetralin ($[\text{VOTPP}]_{\text{initial}} = 2 \text{ mM}$)/water two-phase system.

in **Figure 7-2a(ii)**. In the spectrum of the water phase after 10 h, as shown in **Figure 7-2b(i)**, any signals were scarcely to be observed. These results suggest that the resulting vanadium in water phase has a different oxidation state to that of VOTPP(IV). In order to identify this, an aqueous solution of 1 mol/L L-ascorbic acid, as strong reducing agent, was added to the resulting water phase (pH 2.5), and analyzed by ESR. The spectrum obtained, as shown in **Figure 7-2b(ii)**, indicated the formation of new isotropic 8 line signals. Vanadium(II) is usually unstable in solution (Selbin, 1965), and the new signals detected are therefore attributable to vanadium(IV), thus suggesting that the vanadium is removed into the water phase as the pentavalent(V) state.

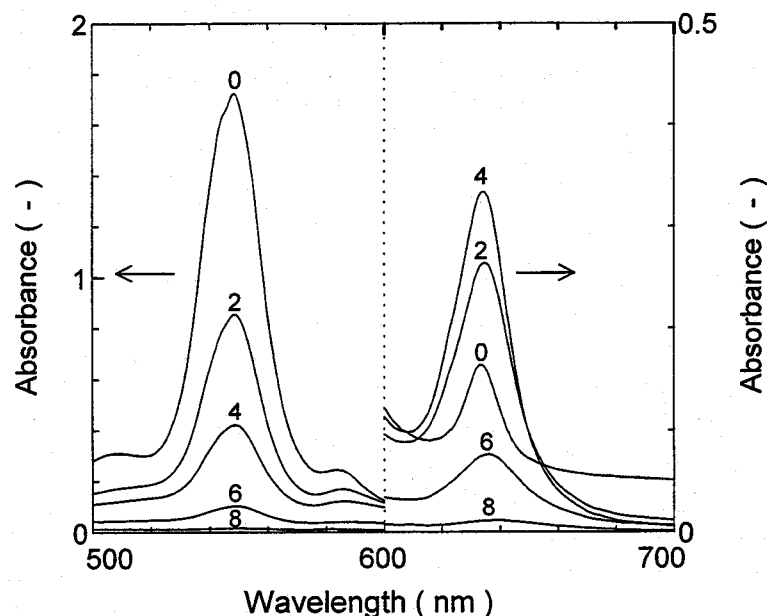

Figure 7-5. Time-course variation in the absorption spectra of the tetralin phase, during photoirradiation to the tetralin ($[\text{VOTPP}]_{\text{initial}} = 2 \text{ mM}$)/water two-phase system under conditions of air bubbling. The numbers in the figure denote the photoirradiation time (h).

Figure 7-4 shows the time-course variation in the concentrations of tetravalent(IV) and pentavalent(V) vanadium in both the tetralin and water phases. In tetralin, the change in the vanadium(IV) concentration is slower than that of the VOTPP and nearly the same as that of the total vanadium, thus indicating that tetravalent(IV) intermediates are produced by the photodecomposition of the VOTPP in tetralin. The change in the pentavalent(V) vanadium in the water phase is also nearly the same as that for the total vanadium, thus suggesting that the vanadium is removed from the tetralin phase, following oxidation from the tetravalent(IV) to the pentavalent(V) state. The variation in the concentration of the VO_3^- ion is seen almost to agree with that of the total vanadium in the water phase. These results suggest therefore that VOTPP(IV) in tetralin is photodecomposed to form tetravalent(IV) intermediates, and that these are further photodecomposed and removed into the water phase as the VO_3^- ion.

The intermediates(IV) formed in tetralin were then identified. **Figure 7-5** shows the time-course variation in the absorption spectra for the tetralin phase during photoirradiation to the tetralin/water two-phase system. The intense absorption band at 543 nm decreased with irradiation time, and a new absorption band at 632–634 nm

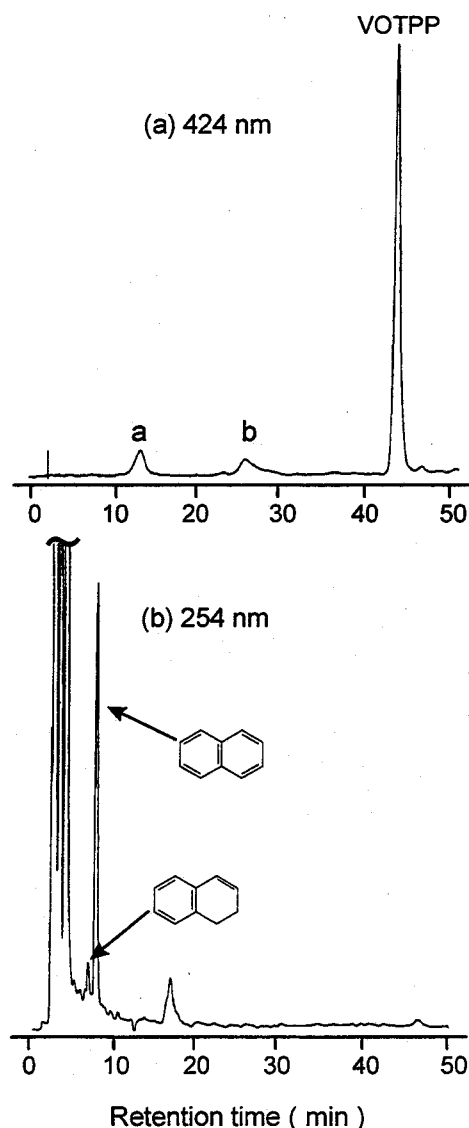

Figure 7-6. LC-chromatograms for tetralin solution, obtained by monitoring at (a) 424 nm and (b) 254 nm, for the samples obtained following 4 h photoirradiation to the tetralin ($[\text{VOTPP}]_{\text{initial}} = 2 \text{ mM}$)/water two-phase system.

increased for irradiation times of up to 4 h. This then decreased, and disappeared following 8 h irradiation. The appearance of this new absorption band thus appears to be attributable to the formation of intermediate compounds. As shown in **Figure 7-6a**, referring to the LC-chromatogram for the tetralin solution obtained following 4 h photoirradiation, two new peaks, “a” and “b”, were detected at the retention times of 13 and 26 min, respectively. Following fractionation and analysis of each peak compound, the “a” compound was found not to involve vanadium atom. On the contrary, the “b” compound, which was a greenish viscous oil, contained vanadium, and therefore the “b”

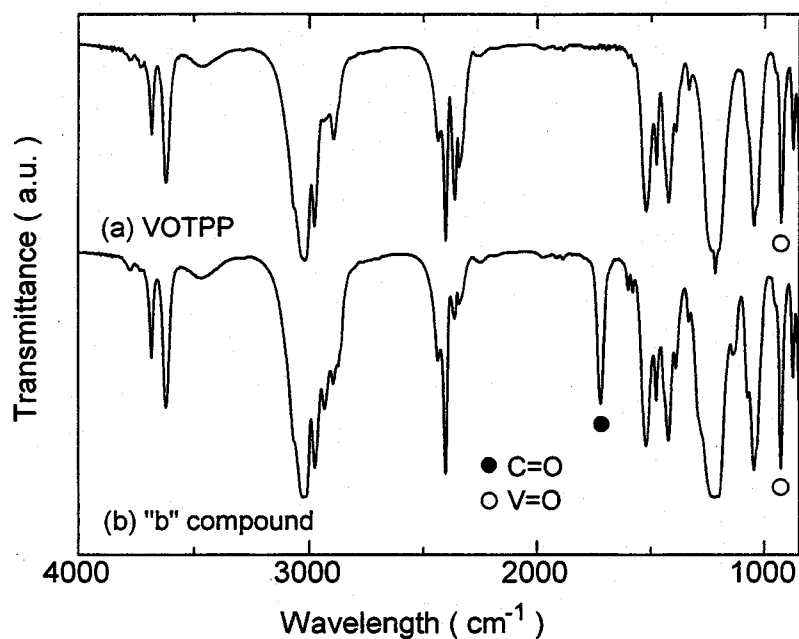

Figure 7-7. IR spectra for (a) VOTPP and (b) the fractionated peak "b" compound.

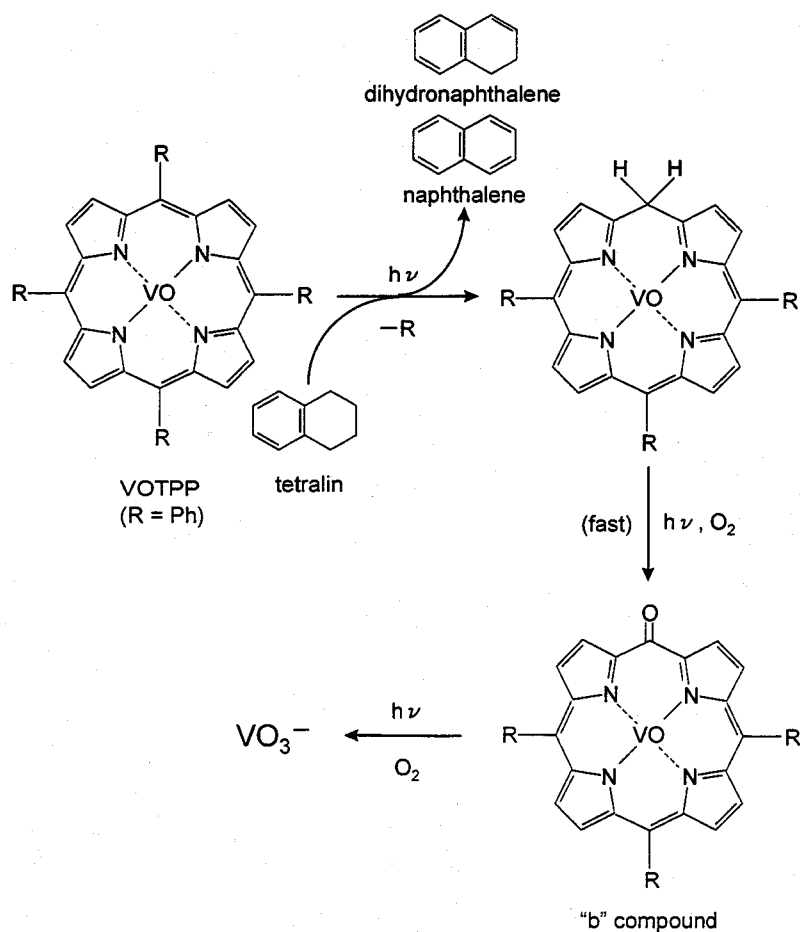

Figure 7-8. The proposed photodecomposition pathway for VOTPP by photoirradiation to the tetralin (containing VOTPP)/water two-phase system.

compound is likely to be the intermediate, which is formed during the photodecomposition of the VOTPP.

Figure 7-7 shows the IR spectra for the VOTPP and the fractionated “b” compound. A carbonyl function (1719 cm^{-1}) appears in the spectra for the “b” compound, but any other apparent change in the spectra was not found. Barrett (1967) has reported that magnesium(II)protoporphyrin is photodecomposed to form biliviolin, which has the meso-position of the porphyrin ring oxygenated, and that this reaction occurs, following the hydrogenation of the *meso*-position. As shown in **Figure 7-6b**, dihydronaphthalene and naphthalene, which are the dehydrogenated products of tetralin, were detected in the LC-chromatograms of the samples obtained by photoirradiation. The results therefore indicate that the “b” compound has a biliviolin like structure, as shown in **Figure 7-8**. The increase in the absorption band at 632–634 nm, as shown in **Figure 7-5**, is thus attributable to the presence of a carbonyl function. Jones et al. (1998) have reported that the photolysis of VOTPP results in the loss of phenyl substituent as well as the loss of a central vanadyl ion. The hydrogenated magnesium(II)protoporphyrin is reported to be oxidized easily to biliviolin in the presence of molecular oxygen (Barrett, 1967). From these results, the phenyl substituent of VOTPP is therefore most likely to be first photodissociated, and then hydrogenated by the withdrawal of the hydrogen from the tetralin. This is then photooxidized, and further photodecomposed to form finally the VO_3^- ion, as shown in **Figure 7-8**.

As shown in **Figure 7-2**, with nitrogen being bubbled into the solution, although the VOTPP concentration decreased, the removal of vanadium from tetralin was suppressed significantly. This is because the hydrogenated VOTPP is not decomposed in the absence of molecular oxygen. In this case, these reactions cause accumulation of the hydrogenated VOTPP in tetralin, thus probably resulting in the decrease in the decomposition rate of the VOTPP. Without gas bubbling, although the VOTPP concentration decreased faster than for nitrogen bubbling, the removal rate of the vanadium from tetralin was more slowly than for both air and oxygen bubbling. This is because the concentration of the molecular oxygen in the solution is smaller than that of the cases for both air and oxygen bubbling. These findings strongly support the proposed photodecomposition mechanism for the VOTPP.

1.3 Demetalation of Nickelporphyrin from Tetralin

The demetalation of nickel(II)tetraphenylporphyrin (NiTPP) from tetralin was then studied. The solubility of NiTPP in tetralin is only about 0.75 mM owing to its low polarity (Freeman et al., 1990). An initial NiTPP concentration of 0.7 mM was therefore employed. **Figure 7-9** shows the rate of demetalation for NiTPP from the tetralin phase. Data for VOTPP are also shown for comparison. These show that the photodecomposition rate for NiTPP is much slower than that for VOTPP and only 7% of the nickel being removed into the water phase, following 10 h photoirradiation. This is probably because the excitation lifetime for NiTPP in solution is very short, and thus internal conversion thus occurs rapidly, as reported (Harriman, 1980; Drain et al., 1998).

Although nickel compounds having an oxidation state of I, III, and V can be determined by ESR measurement, the relevant signals were not detected in the spectra of the tetralin and water phases during photoirradiation. Thus a change in the oxidation state of nickel in the present photochemical process appears not to occur. When hypochlorous acid was added to the resulting water phase, a small black precipitate of NiO was formed, thus indicating that the resulting nickel in the water phase is likely to occur as Ni(OH)₂. **Figure 7-10** shows the variation in the absorption spectra for the tetralin phase during photoirradiation. The absorption band at 618–620 nm was seen to increase with irradiation time, thus indicating that hydrogenation followed by oxidation of the *meso*-position of NiTPP is likely also to occur as for VOTPP. In order to enhance the demetalation of the NiTPP, a new photochemical process, which is capable of accelerating the hydrogenation of the *meso*-position of the NiTPP and the decomposition of the biliviolin like intermediates, appears therefore likely to be required.

1.4 Demetalation of Atmospheric Residue

The present process was applied to the demetalation of atmospheric residue (AR). Since, as shown in **Table 7-1**, the AR is a highly viscous liquid at room temperature, the AR must be diluted to make the mixing and phase separation possible. When the AR was diluted in tetralin alone, the phase disengagement of the resulting emulsion was rather difficult, as the density of the solution is very close to that of water. A mixture of tetralin/decalin (1/1 v/v) was therefore employed as a diluting solution, and 10 wt% AR concentration was adopted as the concentration of the diluted feed mixture. **Figure 7-11**

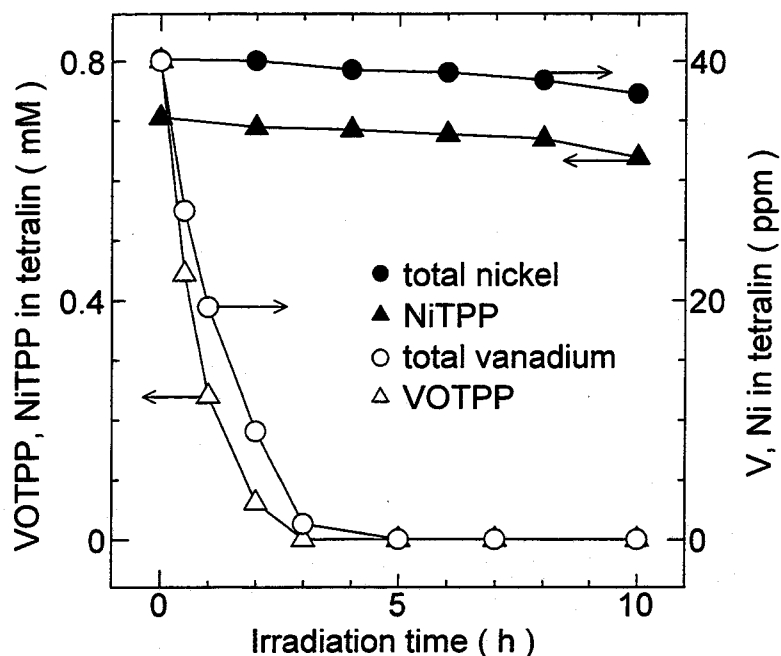

Figure 7-9. Time-course variation in the concentrations of NiTPP, VOTPP, total nickel, and total vanadium in the tetralin phase, during photoirradiation to the tetralin ($[\text{NiTPP}]_{\text{initial}} = 0.7 \text{ mM}$ or $[\text{VOTPP}]_{\text{initial}} = 0.8 \text{ mM}$)/water two-phase system.

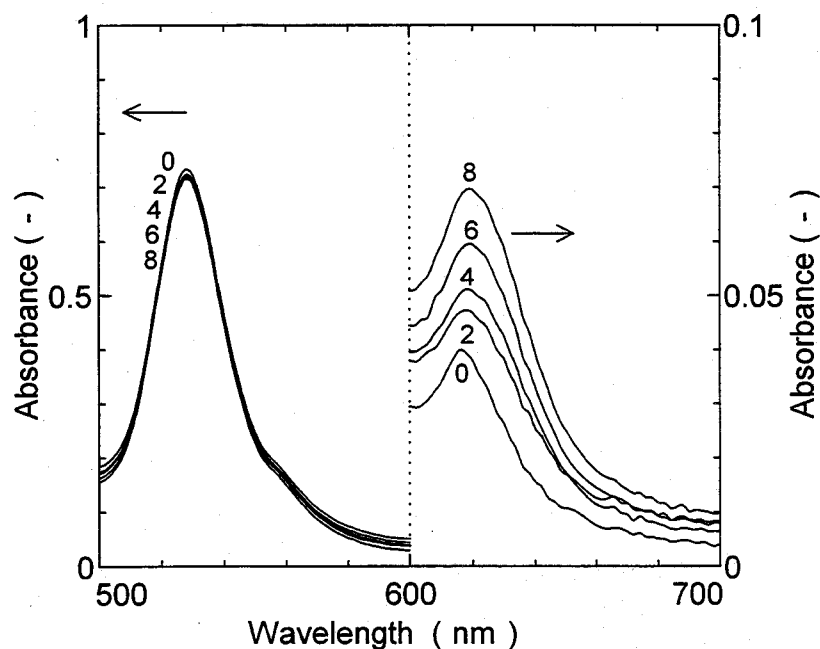

Figure 7-10. Time-course variation in the absorption spectra for the tetralin phase, obtained by photoirradiation to the tetralin ($[\text{NiTPP}]_{\text{initial}} = 0.7 \text{ mM}$)/water two-phase system. The numbers in the figure denote the photoirradiation time (h).

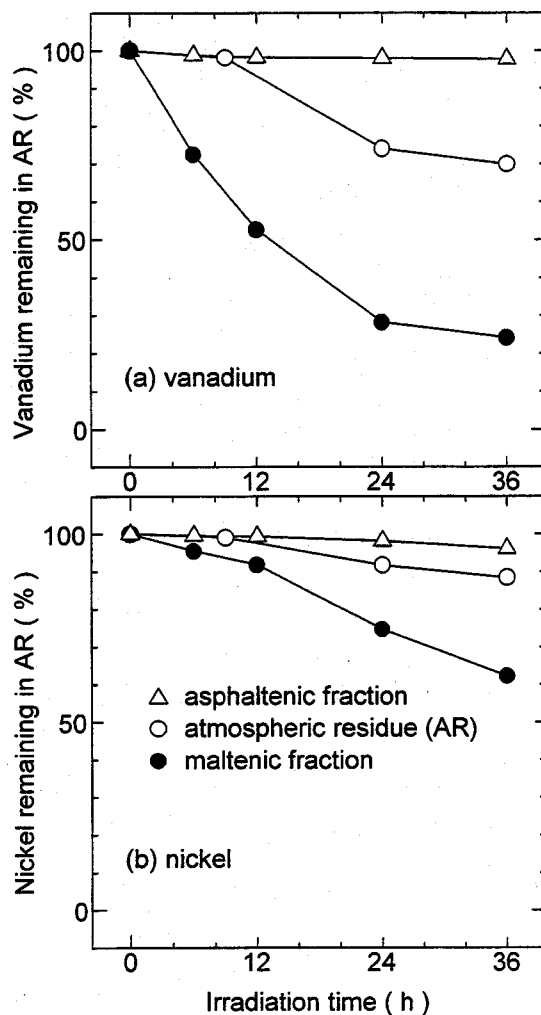

Figure 7-11. Time-course variation in the percentage remaining of (a) vanadium and (b) nickel in AR, and also in its maltenic and asphaltenic fractions, during photoirradiation to the oil/water two-phase system. The residue oil fractions (10 wt%) are dissolved in tetralin/decalin (1/1 v/v) mixture.

shows the time-course variation in the vanadium and nickel percentage remaining in the AR. Although the concentrations for each metal were seen to decrease with irradiation time, 36 h photoirradiation achieved only 30% of the vanadium and 10% of the nickel removal.

Further study was therefore necessary to overcome this limitation. It is known that the AR is fractionated by the solvent deasphalting procedure into two fractions, a “hexane-soluble maltenic fraction” and the other “hexane-insoluble asphaltenic fraction.” The former fraction contains relatively low molecular weight aromatics, whilst the latter contains heavy aromatics, as shown in **Figure 7-12**. The 10 wt% concentration for each

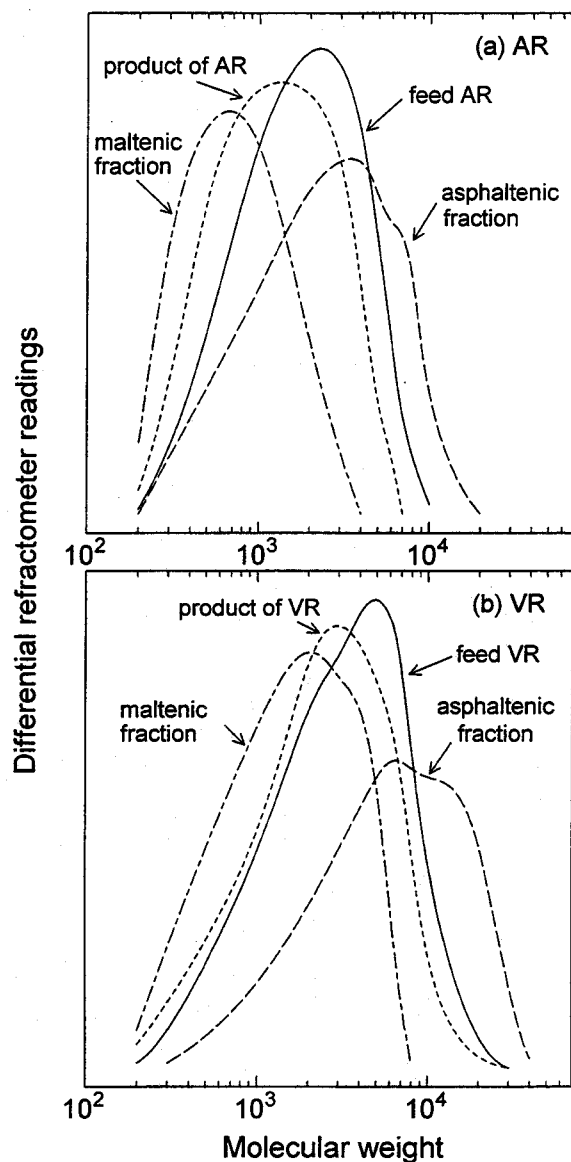

Figure 7-12. Molecular weight distribution for the (a) AR and (b) VR feeds and their maltenic and asphaltenic fractions, and also for the product (a) AR and (b) VR obtained by the present process.

fraction of the AR, dissolved in tetralin/decalin mixture, was therefore photoirradiated as in the case for the total AR. As shown in **Figure 7-11**, the demetalation of the maltenic fraction was seen to proceed rather faster than that for the total AR, and as much as 86% vanadium and 38% nickel were removed, following 36 h photoirradiation. The demetalation of the asphaltenic fraction was, however, significantly more difficult, in that only 1% vanadium and 2% nickel were removed. These results indicate that the low demetallation yield for AR is attributable to the difficulty in the demetalation of the metalloporphyrins, contained in the high molecular weight asphaltenic fraction.

“bound” type metalloporphyrin

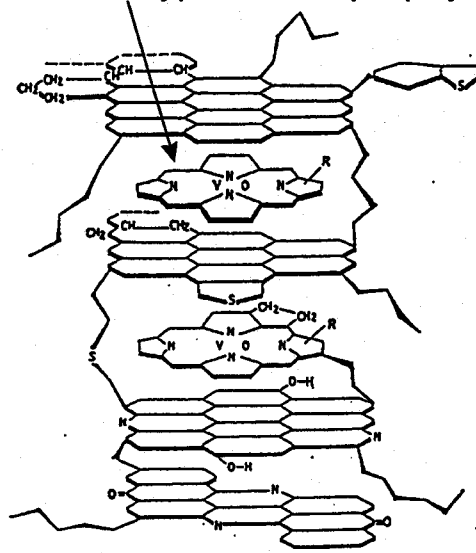

Figure 7-13. Macrostructure of asphaltenic molecule (Tynan and Yen, 1969).

The macrostructure of asphaltene has been studied in detail by several researchers (Dickie and Yen, 1967; Tynan and Yen, 1969; Yamada et al., 1989). It is established that the unit large aromatic sheets having high molecular weights are piled up on each other to form a unit cell and larger associated asphaltenic molecules. The metalloporphyrins are associated with the asphaltenic molecules via π , π -stacking interactions to form “bound” type metalloporphyrins, as schematically shown in **Figure 7-13**. The behavior of the metalloporphyrins during the present demetalation process was therefore studied by ESR measurement. As shown in **Figure 7-14a**, the AR dissolved in the tetralin/decalin mixture showed a 16 feature anisotropic hyperfine structure, thus indicating that most of the metalloporphyrins in AR occur as the “bound” type. The ESR spectrum for the asphaltenic fraction was seen to be identical to that of AR. When the maltenic fraction was analyzed by ESR, new isotropic signals, No. 2 at 3270 and No. 5 at 3560 G, appeared, as shown in **Figure 7-14b**. These are attributable to “free” type vanadylporphyrins, as were found in the spectrum for VOTPP dissolved in tetralin in **Figure 7-2a(i)**. Thus, the maltenic fraction contains “free” type vanadylporphyrins, which do not associate with asphaltenic molecules, in addition to “bound” type vanadylporphyrins. When the maltenic fraction was photoirradiated for 36 h together with distilled water, these isotropic signals

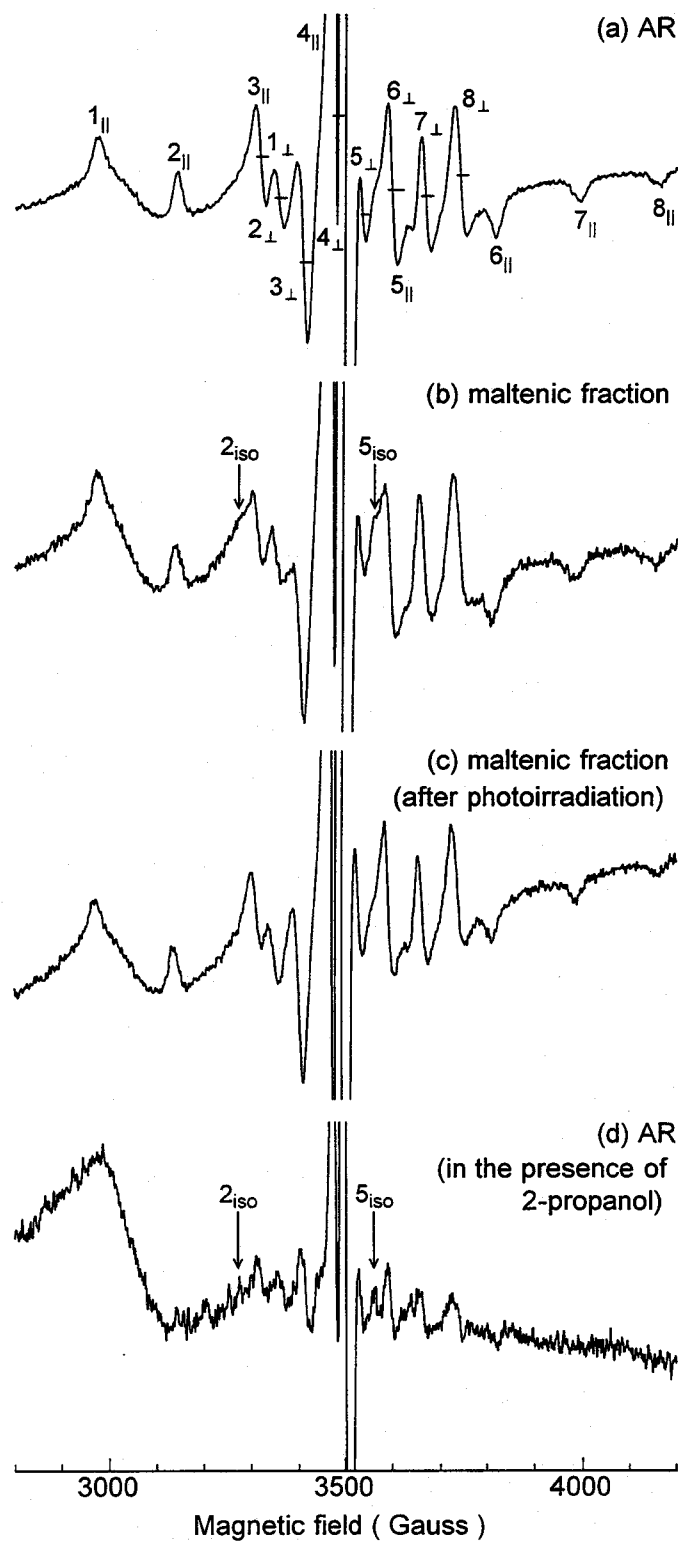

Figure 7-14. ESR spectra for (a) AR (10 wt%) and (b) maltenic fraction (10 wt%) in tetralin/decalin (1/1 v/v) mixture, and spectra for (c) the maltenic fraction obtained following 36 h photoirradiation of oil/water two-phase system and (d) the AR obtained following the addition of 2-propanol.

disappeared, and only the anisotropic signals remained in the spectrum, as shown in **Figure 7-14c**. These results therefore indicate that photoirradiation of the maltenic fraction acts preferentially to photodecompose the “free” type vanadylporphyrins, but is hardly able to demetalize the “bound” type vanadylporphyrins, as shown in **Figure 7-13**. In order to enhance the demetallation of these refractory metalloporphyrins, the interaction between the metalloporphyrins and asphaltenic molecules must therefore be weakened.

2. Demetalation Process Consisting of Photoreaction in the Presence of Alcohol Followed by Liquid–Liquid Extraction

2.1 Photodecomposition of Vanadyl and Nickelporphyrins

The photodecomposition of VOTPP and NiTPP in tetralin is initiated by hydrogenation at the *meso*-position of their porphyrin rings, in which the tetralin solution acts as the hydrogen source. Thus if protic solvents such as alcohols are added to the solution, the photodecomposition of the metalloporphyrins may then be accelerated. The photoreactivity of the metalloporphyrins in the presence of alcohol was therefore examined. Several alcoholic solvents (50 mL) were added to the tetralin solution (100 mL), and the resulting homogeneous solutions photoirradiated with air bubbling. **Figure 7-15** shows the time-course variation for the concentrations of VOTPP and NiTPP in tetralin/alcohol mixture. As expected, the photodecomposition of these metalloporphyrins is accelerated by the addition of the alcohols, with the greatest rate enhancement being obtained in the case of 2-propanol, when employed for both VOTPP and NiTPP. The photodecomposition rate for both VOTPP and NiTPP is also enhanced by increasing the added volume of 2-propanol.

Figure 7-16 shows the time-course variation in the absorption spectra for VOTPP and NiTPP in tetralin/2-propanol mixture during photoirradiation. The absorption band at 632–634 nm for VOTPP and 618–620 nm for NiTPP first increases, and then decreases with irradiation time, thus indicating that photodecomposition proceeds via the same mechanisms, as previously found for the tetralin/water two-phase system. During photoirradiation, a small amount of acetone, as the dehydrogenated product of 2-propanol, was detected by GC analyses for both VOTPP and NiTPP. These results therefore

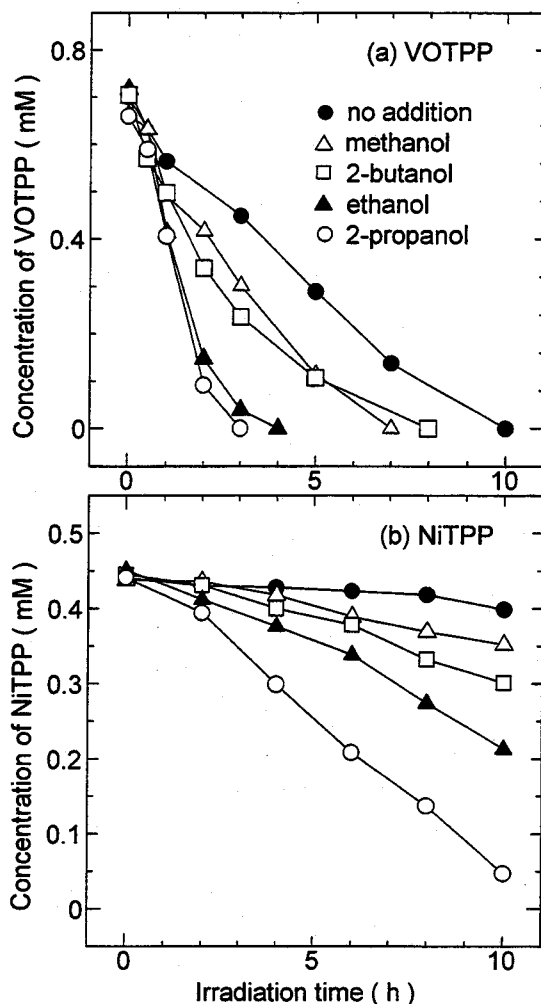

Figure 7-15. Effect of the addition of alcoholic solvents on the time-course variation in the concentrations of (a) VOTPP and (b) NiTPP in tetralin at a volume ratio for alcohol/tetralin of 50/100 mL/mL.

suggest strongly that the photodecomposition of both VOTPP and NiTPP is accelerated by hydrogen withdrawal from the 2-propanol.

The extraction of the photodecomposed vanadium and nickel compounds from the resulting tetralin solution was then carried out. Following 10 h photoirradiation of the tetralin/2-propanol mixture, both acetone product and 2-propanol were removed completely by evaporation, and the resulting tetralin solution then contacted with an equal volume of various acidic and basic aqueous solutions for 10 min at room temperature. The extraction yields for vanadium and nickel, summarized in **Table 7-2**, showed that a 1 mol/L HCl aqueous solution is the most suitable solvent for the extraction, with 99.6% of the photodecomposed vanadium and 99.7% of the nickel being extracted successfully. A

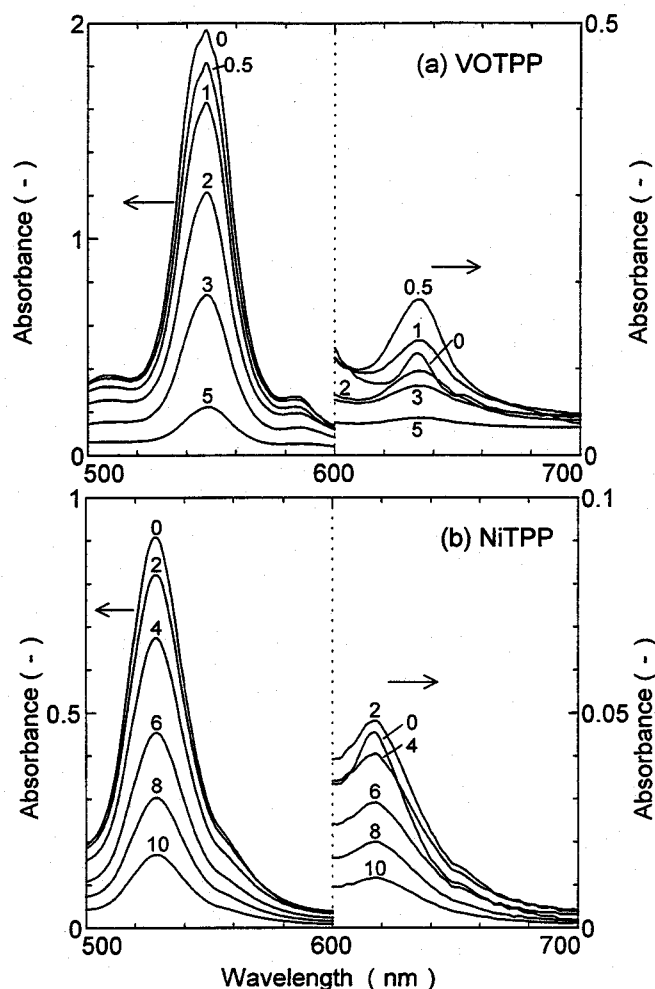

Figure 7-16. Time-course variation in the absorption spectra for (a) VOTPP and (b) NiTPP, during photoirradiation to the tetralin/2-propanol (100/50 mL/mL) mixture. The numbers in the figure denote the photoirradiation time (h).

1 mol/L HCl aqueous solution was therefore employed throughout the succeeding experiments.

Most of the vanadyl and nickelporphyrins in residue oils are known to occur naturally as octaethyl (OEP) and etioporphyrins (ETIO) (Reynolds et al., 1987; Verne-Minster et al., 1990; Didik et al., 1975), as shown in **Figure 7-17**. The photoreactivity of these metalloporphyrins, which lack alkyl substituents on their *meso*-position, was also studied. These particular vanadyl and nickelporphyrins were synthesized, and photoirradiated in tetralin/2-propanol (100/50 mL/mL) mixture. **Figure 7-18** shows the time-course variation in the concentrations of the vanadyl and nickelporphyrins. The concentration of each metalloporphyrin decreased with photoirradiation time at a rate which was much

Table 7-2. Effect of Differing Aqueous Solutions on the Extraction of Photodecomposed Vanadium and Nickel Compounds from Tetralin, Following 10 h Photoirradiation to the Tetralin/2-Propanol (100/50 mL/mL) Mixture ([VOTPP]_{initial} = 0.7 mM; [NiTPP]_{initial} = 0.44 mM)^a

aqueous solutions	extraction	
	vanadium (%)	nickel (%)
distilled water (pH 6.2)	76.7	77.1
NaOH (1 mol/L)	90.2	79.6
HCl (1 mol/l)	99.6	89.0
H ₂ SO ₄ (1 mol/L)	93.3	83.9
HNO ₃ (1 mol/L)	93.1	82.5

^a Photodecomposition yields for VOTPP and NiTPP are 100% and 89.3%, following 10 h photoirradiation.

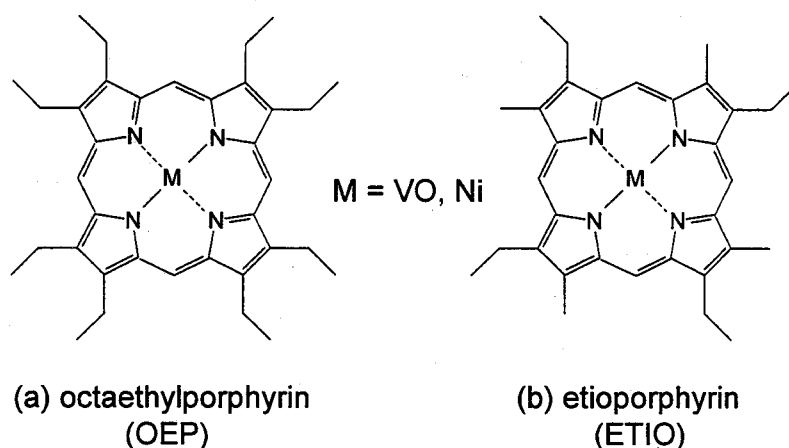

Figure 7-17. Structure of (a) metalloctaethylporphyrins (OEP) and (b) metalloetioporphyrins (ETIO).

faster for both cases of the vanadyl and nickelporphyrins than for the tetraphenylporphyrin (TPP) derivatives. These metalloporphyrins do not have phenyl substituents on the *meso*-position of the porphyrin ring, and thus a higher conversion for OEP and ETIO is likely to be attained. On contacting the resulting tetralin solution with 1 mol/L HCl aqueous solution, nearly 100% of both the photodecomposed vanadium and nickel was successfully extracted. From these results, these metalloporphyrins in residue oil, having no alkyl substituents on their *meso*-position, were thus found to be demetalized satisfactorily by the present process.

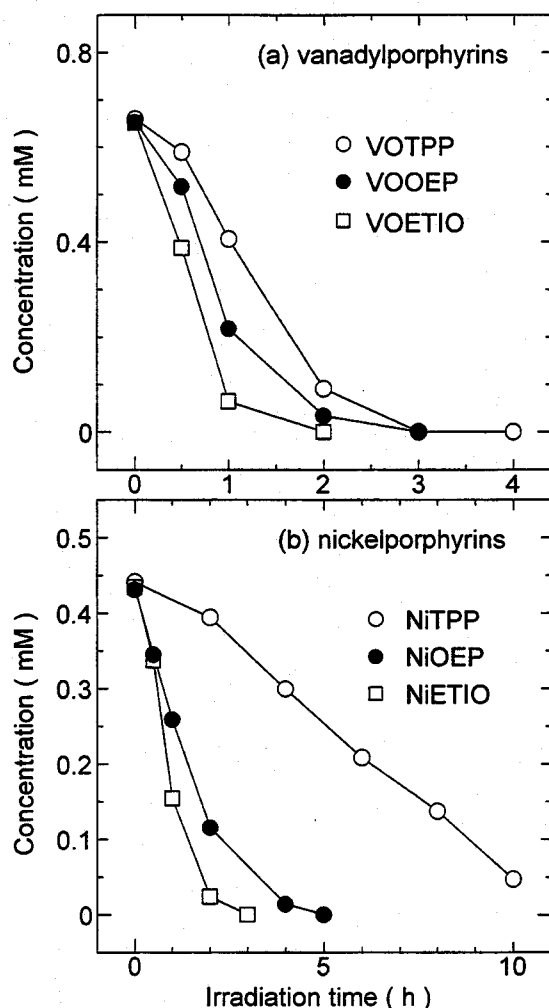

Figure 7-18. Time-course variation in the concentration of (a) VOOEP, VOETIO, and VOTPP, and (b) NiOEP, NiETIO, and NiTPP in the tetralin/2-propanol (100/50 mL/mL) mixture, during photoirradiation.

2.2 Demetalation of Residue Oils

The new demetalation process, which consists of the photodecomposition of metalloporphyrins in the presence of 2-propanol followed by liquid-liquid extraction, was applied to the demetalation of residue oils. 2-Propanol (50 mL) was added to 10 wt% atmospheric residue (AR) dissolved in tetralin/decalin (1/1 v/v) mixture (100 mL) and photoirradiated. The 2-propanol was then removed completely by evaporation, and the resulting solution was contacted with an equal volume of 1 mol/L HCl aqueous solution. **Figure 7-19** shows the time-course variation in the percentage vanadium and nickel remaining in AR solution. The remaining percentage for both vanadium and nickel is seen to decrease drastically, in that 93% vanadium and 98% nickel were removed following 36 h photoirradiation. Demetalation for the asphaltenic fraction of AR was

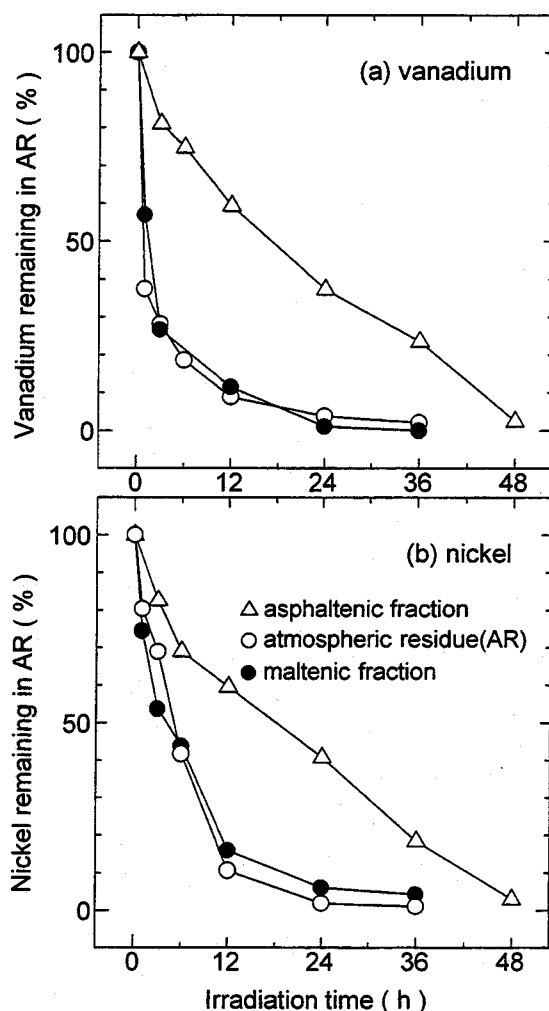

Figure 7-19. Time-course variation in the percentage remaining of (a) vanadium and (b) nickel in AR, and in its maltenic and asphaltenic fraction samples obtained by demetalation. The oils (10 wt %) were dissolved in tetralin/decalin (1/1 v/v) mixture.

also improved with the present process. Seventy-six percent vanadium and 80% nickel were removed following 36 h photoirradiation, although only 1% vanadium and 2% nickel were removed, when employing the previous oil/water two-phase system. On irradiating the asphaltenic fraction for 48 h, the remaining percentage for both metals was decreased to less than 2%.

The behavior of the metalloporphyrins in residue oil, according to the present process was examined by ESR measurements. As shown in **Figure 7-14d**, the 16 feature anisotropic signals, originally observed in the spectrum for AR (10 wt%) in tetralin/decalin mixture (**Figure 7-14a**), disappeared by the addition of the 2-propanol, and the new isotropic signals, No. 2 and No. 5, apparently appeared, thus indicating the

presence of the "free" type vanadylporphyrins. Tynan and Yen (1967) have reported that similar changes in the ESR spectra for the asphaltenic fraction also occur consequent to the addition of polar THF and pyridine. Dunning et al. (1953) have reported that considerable amounts of metalloporphyrins are extracted from the asphaltenic fraction on contacting with 2-propanol. These results therefore suggest that, in the present process, the "bound" type metalloporphyrins, which are associated with the asphaltenic molecules, are dissociated by the addition of polar 2-propanol and thus converted to "free" type metalloporphyrins. These are then photodecomposed successively by UV irradiation in the presence of 2-propanol, thus resulting in the high demetalation yields for AR and for the asphaltenic fraction. During demetalation of residue oils, the demetalation yield for nickel was slightly higher than that for vanadium, even though the photodecomposition rate for NiTPP in tetralin is slower than that for VOTPP, as shown in **Figure 7-15**. This is because the association of the nickelporphyrins with asphaltenic molecules is rather weaker than that of the vanadylporphyrins due to their low polarity, such that their dissociation from the asphaltenic molecules may occur more easily in the presence of 2-propanol.

The present process was also applied to the demetalation of vacuum residue (VR), which, as shown in **Figure 7-12**, contains higher molecular weight aromatic compounds than AR. **Figure 7-20** shows the time-course variation in the remaining percentage of vanadium and nickel in VR. The percentage remaining for the both metals decreased with irradiation time, in that 73% vanadium and 85% nickel were removed following 36 h photoirradiation. For the asphaltenic fraction, 55% vanadium and 83% nickel were removed successfully by the present process. The demetalation rate for VR is seen to be slightly slower than that for AR. This is because the association of the metalloporphyrins with the asphaltenic molecules increases with increasing molecular weight of the asphaltenic molecules (Yamada et al., 1989). In current petroleum refineries, most of the VR, produced during the vacuum distillation of the atmospheric residue, is used as road-asphalt or petroleum coke, since the VR contains large quantities of vanadium and nickel, which are not demetalized sufficiently by the present hydrodemetalation (HDM) process. By use of the present process, the demetalation of such heavy residual feedstocks may now be carried out satisfactorily under moderate operating conditions with only air

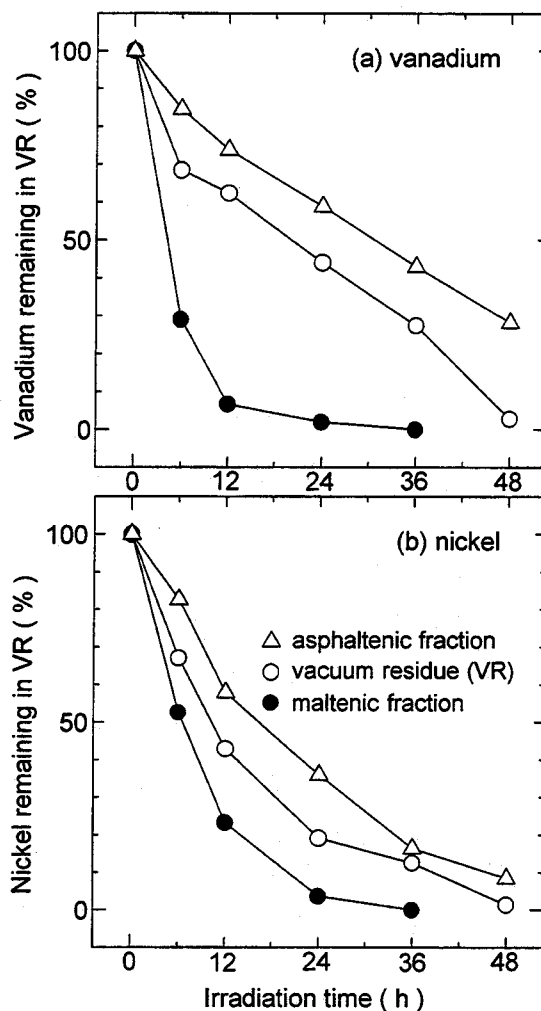

Figure 7-20. Time-course variation in the percentage remaining of (a) vanadium and (b) nickel in VR, and in its maltenic and asphaltenic fraction samples obtained by the demetalation. The oils (10 wt%) were dissolved in tetralin/decalin (1/1 v/v) mixture.

bubbling, such that the product may now be used not only for road-asphalt or petroleum coke but also for fuel oils. The relatively long photoirradiation time required in the present study may be expected to be reduced considerably for industrial application via the development of a more efficient photoreactor of appropriate advanced design.

2.3 Properties of Residue Oil Products and Organization of the Process

The properties of the demetalized residue oil products were studied. Following demetalation of the residue oils and their maltenic and asphaltenic fractions, the tetralin and decalin solvents were removed by evaporation, and the resulting products then analyzed. The results obtained are summarized in **Table 7-1**. Consequent to this procedure, the concentrations for vanadium and nickel in AR were decreased from 118 to

2.4 and from 39 to 0.4 ppm. Those for VR were also decreased from 162 to 44.4 and from 49.1 to 6.1 ppm, respectively. The density and the viscosity for the product AR and VR were seen to decrease slightly compared with those of the original feeds. According to GPC analysis, the molecular weight distribution for these products becomes lower than for the feeds, as shown in **Figure 7-12**. In the IR spectra for the products, a strong absorption band appeared at 1600–1800 cm^{-1} (carbonyl function), and the aromaticity of the samples, determined according to the method of Boukir et al. (1998), decreased slightly. These results suggest that the asphaltenic molecules are partially photooxidized by UV irradiation (Boukir et al., 1998; Fujishiro et al., 1979) and are further photodecomposed to form smaller molecules. The sulfur and nitrogen contents of the feeds were, however, hardly decreased during the present process. This is because these elements are distributed widely within the asphaltenic molecules. A sequential process for the removal of sulfur and nitrogen is therefore required for the use of the products as fuel oils.

Based on the above results, a basic flow scheme for an overall demetalation process, involving the recovery of 2-propanol, was formulated and is shown in **Figure 7-21**. Commercial heavy oil is prepared by mixing residue oil with light cycle oil, produced during the fluid catalytic-cracking of vacuum gas oil. The light cycle oil contains large quantities of monocyclic aromatics (tetralin derivatives), as described in Chapter I and III, and thus no significant difference exists between the present tetralin/decalin mixture and the light cycle oil used as diluent. The process sequence is as follows. (1) The residue oil is mixed with light cycle oil from the catalytic cracking units. (2) 2-Propanol is added to the residue oil solution, and the resulting solution sent to the photoreactor. (3) The solution is then photoirradiated under moderate conditions with air bubbling. (4) The 2-propanol is recovered from the solution by distillation and is reused for further demetalation. (5) The solution is then mixed with aqueous HCl solution for extraction of the photodecomposed metal-containing compounds. (6) The resulting mixture is demulsified in an electric field. The residue oil solution is then separated, and sent for further refining (e.g. desulfurization or cracking). Vanadium and nickel in aqueous HCl solution are sent on to further hydrometallurgical processes for the recovery of these rare metals. The proposed process comprises very simple stages, and is carried out under

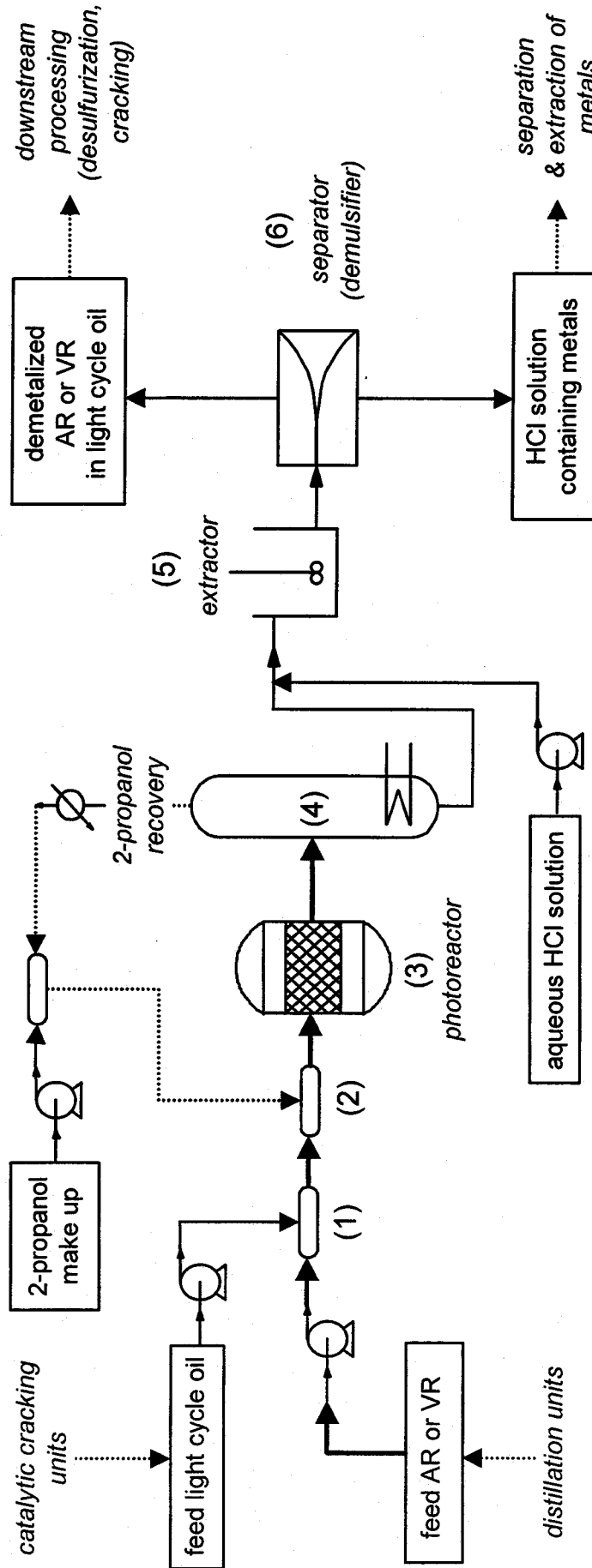

Figure 7-21. A basic flow scheme for the proposed demetallation process for residue oils. The individual sections are (1) mixing of the residue oil with light cycle oil, (2) mixing of the residue oil solution with 2-propanol. (3) demetallation, (4) evaporation (2-propanol regeneration), (5) extraction of photodecomposed metals, and (6) demulsification and separation of residue oil solution/water emulsion.

moderate conditions with only air bubbling. Therefore, the present process will be applicable as a safe and energy-efficient upgrading process for petroleum residue feedstocks.

Summary

Demetalation process for vanadyl and nickel porphyrins from residue oils, effected by a combination of photochemical reaction and liquid-liquid extraction, has been investigated, and the following results were obtained.

1) A simultaneous photoreaction and extraction process using an oil/water two-phase system was first studied. Vanadyl(IV)tetraphenylporphyrin dissolved in tetralin is photodecomposed by UV irradiation, and the resulting VO_3^- is removed into the water phase under moderate conditions. The demetalation of nickel(II)tetraphenylporphyrin from tetralin, however, hardly occurs according to the present process, since the excited lifetime for nickelporphyrin is very short.

2) The demetalation of vanadium and nickel from atmospheric residue is significantly difficult, in that only 30% vanadium and 10% nickel are removed, even following 36 h photoirradiation. ESR measurements showed that the present process is able to demetalize "free" type metalloporphyrins, but has difficulty in the demetalation of "bound" type metalloporphyrins, which strongly associated with the asphaltenic molecules.

3) To cope with the limitation of the above process, a new process, which consists of the photodecomposition of metalloporphyrins in the presence of 2-propanol with following extraction, was studied. The association of the metalloporphyrins with the asphaltenic molecules in residue oils is weakened by the addition of 2-propanol to produce "free" type metalloporphyrins. The photodecomposition of the metalloporphyrins is thus much enhanced, and the resulting metals are extracted quantitatively by contact with aqueous HCl solution.

4) Employing the present process enabled nearly 100% vanadium and nickel to be removed from the atmospheric residue following 36 h photoirradiation. The 78% vanadium and 85% nickel were also recovered successfully from vacuum residue, which

contains high molecular weight aromatics. An overall process involving the recovery of the 2-propanol was also formulated, with the present process being applicable as an energy-saving process for the upgrading of residue oils.

General Conclusions

This work described “*photochemical refining*” processes for petroleum derived middle or heavy feedstocks, based on photochemical reaction and liquid–liquid extraction. The photochemical reaction was spiked with functional materials, such as triplet photosensitizer and electron-transfer photosensitizer, in addition to the direct photoexcitation of objectionable compounds. The desulfurization, denitrogenation, and demetalation processes for light oils, catalytic-cracked gasoline, and residue oil were developed using three extraction and photoreaction systems, such as oil/water, oil/acetonitrile, and oil/2-propanol. These processes were applied to the processing for feedstocks, having different sulfur, nitrogen, and metal content and hydrocarbon composition. The desulfurization studies were presented in Chapter I–V, and denitrogenation and demetalation studies presented in Chapters VI and VII, respectively.

In Chapter I, photoreactivities and desulfurization behavior of sulfur-containing compounds in light oils (dibenzothiophenes (DBTs), benzothiophenes, and alkylsulfides) were studied as a first step, using an oil/water two-phase system, under irradiation of entire wavelength region of light from high-pressure mercury lamp. Photodecomposition of DBTs and its alkyl-substituted derivatives in light oils was found to be suppressed significantly by the presence of large amount of bicyclic aromatics (naphthalene derivatives), whereas alkylsulfides and benzothiophenes were desulfurized effectively. The addition of benzophenone (BZP), a triplet photosensitizer, enhanced the removal of DBT from tetradecane. This photosensitizing reaction was, however, suppressed significantly by the presence of naphthalene and no acceleration in the desulfurization of DBT was observed, because of the triplet energy transfer from photoexcited DBT or BZP to ground-state naphthalene.

In Chapter II, effect of the addition of hydrogen peroxide into the water phase was studied using an oil/water two-phase system. The addition of H_2O_2 enhanced the desulfurization of DBTs, even in the presence of naphthalene, since the H_2O_2 oxidizes the photoexcited DBTs before deactivation. The sulfur content of light oils was decreased successfully, under the irradiation of entire wavelength region of light, to less than 0.05 wt% at 30% H_2O_2 concentration and 24 h photoirradiation, although the

photodecomposition of H_2O_2 was actually seen. The addition of both triplet photosensitizer (benzophenone: BZP) and H_2O_2 enhanced the removal of DBT under the irradiation of relatively long-wavelength light ($\lambda > 280 \text{ nm}$), suppressing the photodecomposition of H_2O_2 . The desulfurization of light oils was also enhanced by the present method, in that the sulfur content was reduced effectively to less than 0.05 wt% by 48 h photoirradiation and at 30% H_2O_2 and 100 mM BZP concentrations. The resulting sulfur compounds removed into the water phase could be separated from aqueous H_2O_2 solution, without decomposition of H_2O_2 , by a solid phase adsorption process using aluminum oxide adsorbent. The recovered H_2O_2 solution thereby could be recycled for further desulfurization.

In Chapter III, desulfurization of light oils was investigated using an organic two-phase extraction system, under irradiation of entire wavelength region of light. When the light oil and acetonitrile was contacted and photoirradiated, the sulfur-containing compounds were extracted into the acetonitrile phase and photodecomposed there effectively. The adverse effect of naphthalene on the photodecomposition of DBTs was suppressed significantly in the acetonitrile. The photoproducts are highly polarized compounds, which do not distribute into the nonpolar light oil phase, thus providing successive distribution of sulfur-containing compounds from light oil to acetonitrile. By the present process, sulfur content of light oils was decreased successfully to less than 0.005 wt% by 10 h photoirradiation and at a higher acetonitrile/light oil volume ratio. Aromatic hydrocarbons, distributed together with sulfur-containing compounds into the acetonitrile phase, were recovered successfully by extraction using light paraffinic hydrocarbons, leaving photodecomposed sulfur-containing compounds in acetonitrile. The overall desulfurization process for light oils was proposed, in which all the solvents and water can be recirculated.

In Chapter IV, desulfurization of light oils, based on visible light-induced ($\lambda > 400 \text{ nm}$) electron-transfer oxidation and organic two-phase extraction, was investigated, using 9,10-dicyanoanthracene (DCA) as an electron-transfer photosensitizer. Sulfur-containing compounds, when dissolved in acetonitrile, were indirectly photooxidized via the photoexcitation of DCA to form highly polarized compounds, which do not distribute into the nonpolar light oil phase. The sulfur-containing compounds were photooxidized

selectively, even in the presence of large amount of aromatic hydrocarbons. When light oil and acetonitrile were mixed and photoirradiated in the presence of DCA, the deep desulfurization of light oil was achieved successfully. The DCA dissolved in acetonitrile was recovered by extraction with *n*-hexane, together with aromatic hydrocarbons. The DCA dissolved in light oil was recovered by the adsorption method using silica gel, and was totally desorbed by elution with an acetonitrile/water azeotropic mixture, which can be reused for further desulfurization. The overall desulfurization process, consisting of desulfurization and the recovery of aromatics, DCA, and solvents, was formulated, and the results obtained showed that the present process is applicable for the deep desulfurization of light oils.

In Chapter V, the desulfurization process for light oils, using visible light irradiation ($\lambda > 400$ nm) and organic two-phase extraction, was applied to the desulfurization of catalytic-cracked gasoline (CCG). Individual sulfur-containing compounds (thiophenes, tetrahydrothiophene, thiol, and disulfide), when dissolved in acetonitrile, were photooxidized in the presence of DCA, to form highly polarized compounds, which do not distribute into the nonpolar gasoline. The desulfurization of CCG was achieved, in that the sulfur content was reduced successfully from 100 to less than 30 ppm. The sulfur-containing compounds were photooxidized selectively, even in the presence of olefins. The research octane number for CCG hardly decreased by desulfurization, suggesting that the present process is applicable for selective desulfurization of CCG. DCA dissolved in the acetonitrile could be recovered by the addition of water, followed by further contact with CCG, thus enabling the recovered DCA to be recycled for further desulfurization. The overall desulfurization process, consisting of desulfurization and the recovery of DCA and solvents, was thus fully organized.

In Chapter VI, the denitrogenation of light oils, using oil/water and organic two-phase systems, was investigated. The entire wavelength region of light was utilized for both systems. In the oil/water system, although anilines and indoles were photodecomposed effectively, photodecomposition of carbazoles was strongly suppressed by triplet energy transfer from photoexcited carbazole to ground-state bicyclic aromatic hydrocarbons. The photodecomposition of carbazole was enhanced by the addition of H_2O_2 into the water phase. The denitrogenation of light oils was thereby much enhanced, and the

nitrogen contents of light oils were decreased to less than 20% of the feed value (240 ppm) by 10 h photoirradiation and at a 30% H₂O₂ concentration. In the organic two-phase system, the nitrogen-containing compounds in light oils were extracted into the acetonitrile phase, and were photodecomposed there to form NO₃⁻ ion. The successive removal of the nitrogen-containing compounds from light oils to acetonitrile was thereby carried out, and the nitrogen contents of light oils were decreased successfully to less than 3% of the feed concentration by 10 h photoirradiation at a higher acetonitrile/oil volume ratio. Both the proposed processes enabled the simultaneous removal of sulfur and nitrogen from light oils.

In Chapter VII, demetalation process for residue oils was studied by the irradiation of entire wavelength region of light. An oil/water two-phase system was first studied. Vanadyl(IV) and nickel(II)tetraphenylporphyrins, when dissolved in tetralin, were photodecomposed, and resulting metal ions were removed successfully into the water phase. The demetalation of vanadium and nickel from atmospheric residue was, however, significantly difficult. ESR measurements showed that the present process is able to demetalize "free" type metalloporphyrins, but has difficulty in the demetalation of "bound" type metalloporphyrins, which strongly associate with asphaltenic molecules. To cope with this limitation, a new process, consisting of the photodecomposition of metalloporphyrins in the presence of 2-propanol and succeeding extraction, was then studied. The association of the metalloporphyrins with asphaltenic molecules in residue oils was weakened by the addition of 2-propanol to produce "free" type metalloporphyrins. The photodecomposition of the metalloporphyrins was thus much enhanced, and the resulting metal ions were extracted quantitatively by contact with aqueous HCl solution. Employing the process enabled nearly 100% vanadium and nickel to be removed from the atmospheric residue following 36 h photoirradiation. The 78% vanadium and 85% nickel were also recovered successfully from vacuum residue, which contains high molecular weight aromatics. An overall process, involving the recovery of the 2-propanol, was formulated.

The results obtained by this dissertation work are summarized in **Figure 8-1**. The light oil and catalytic-cracked gasoline are purified through the proposed photochemical desulfurization and denitrogenation processes. The photochemical demetalation for

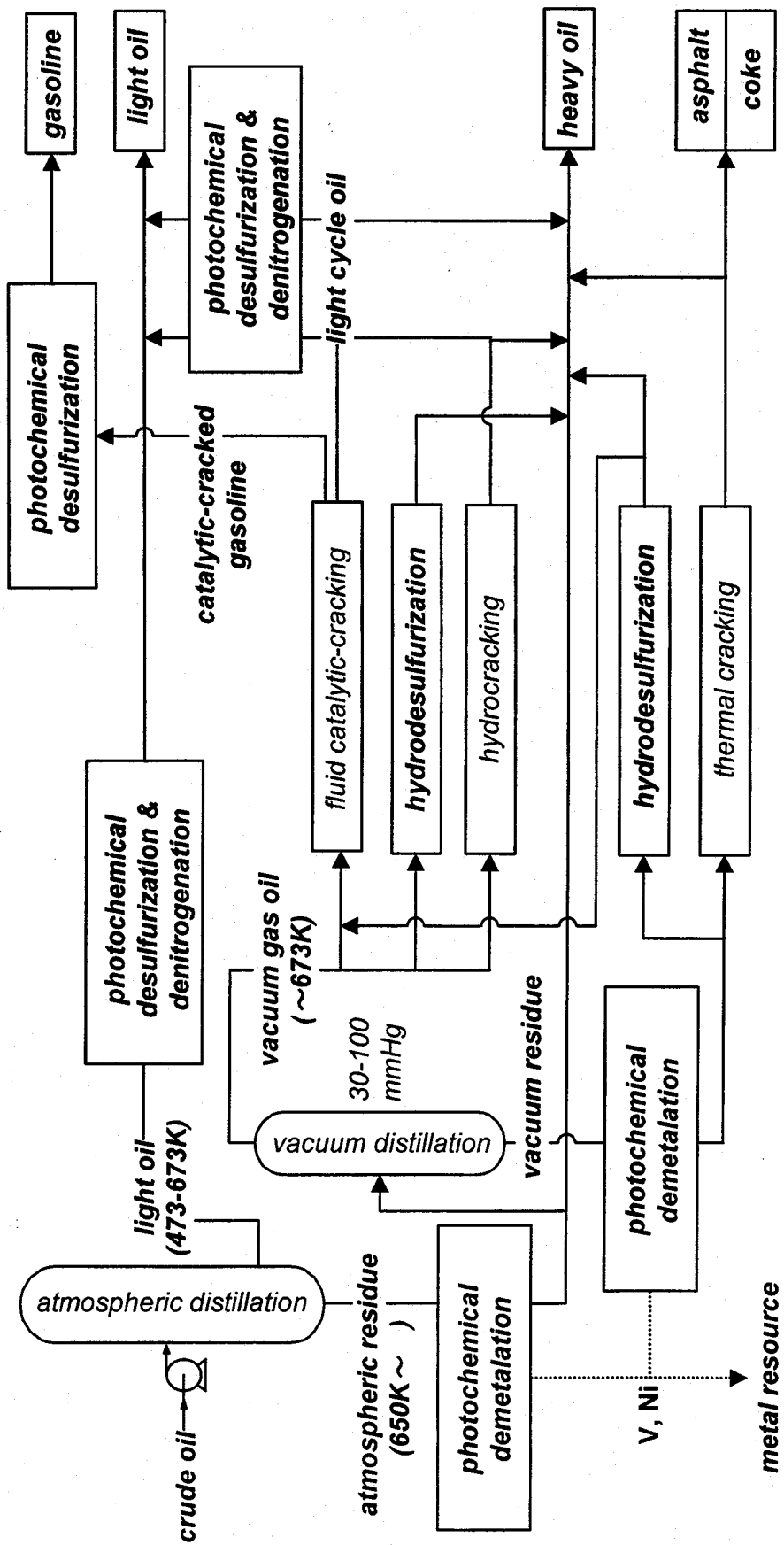

Figure 8-1. A combination scheme of the current petroleum refining processes and the proposed photochemical refining processes.

residue oils are carried out, prior to the hydrotreating processes. The vanadium and nickels are thereby removed in these sections, and the poisoning of the catalysts, occurring in the succeeding hydrotreating processes, may thus be much reduced. The vanadium and nickel recovered are used as metal resources. All the proposed processes have any subjects such as the reduction of the reaction time and realization of a mass treatment. However, the significance of the concepts proposed in these studies will certainly be increased in the near future.

Suggestions for Future Work

This dissertation work described novel refining processes, which can be called “*photodecomposition and extraction*” method. During this dissertation work, a completely different desulfurization method has been found, which can be called “*alkylation and precipitation*,” method. This is described as a related work.

Acheson and Harrison (1969; 1970) have reported that BT and DBT are methylated by methyl iodide (CH_3I), alkylating agent, in the presence of silver tetrafluoroborate (AgBF_4), to give rise at room temperature to crystalline powders of the corresponding S-methylthiophenium tetrafluoroborate. These thiophenium salts are highly polarized (water-soluble) and are insoluble to nonpolar solvents. Thus such a synthetic method, if applied to the desulfurization of nonpolar light oil, might thus be able to remove the BTs and DBTs specifically from the light oil as a precipitate and under moderate conditions. Based on this new concept, the investigation concerning this “*alkylation and precipitation*” method was initiated. The results obtained are summarized as follows:

The $\text{S}_{\text{N}}2$ displacement reaction (**Figure 9-1**) occurring between sulfur-containing compounds and $\text{CH}_3\text{I}-\text{AgBF}_4$ complex was very slow in nonpolar light oils. The addition of organic-soluble polar solvent, such as dichloromethane (CH_2Cl_2), was however found to accelerate the reaction, and enable the deep desulfurization at atmospheric pressure and room temperature. The sequential procedure is as follows: AgBF_4 (1.76 mmol) and CH_3I (15.7 mmol) were added to the homogeneous solution of light oil (15 mL; sulfur content, 0.18 wt% (0.78 mmol)) and CH_2Cl_2 (15 mL) under a nitrogen atmosphere and at 303 K. The resulting AgI precipitate was filtered off and washed with CH_2Cl_2 . The CH_2Cl_2 and CH_3I were then removed by evaporation. Upon cooling the resulting light oil, a dark green viscous liquid (0.1076 g) was found to adhere to the bottom of the flask, such that the light oil could therefore be recovered easily by decantation (recovery: 99.6%).

By employing this procedure, the sulfur content of the light oil was thereby decreased from 0.18 wt% to 0.04 wt% for only 0.5 h reaction time, and the 92% of sulfur removed from the light oil was contained in the precipitate. The rate of the present $\text{S}_{\text{N}}2$ displacement reaction depends on the concentrations of both the sulfur compounds and of

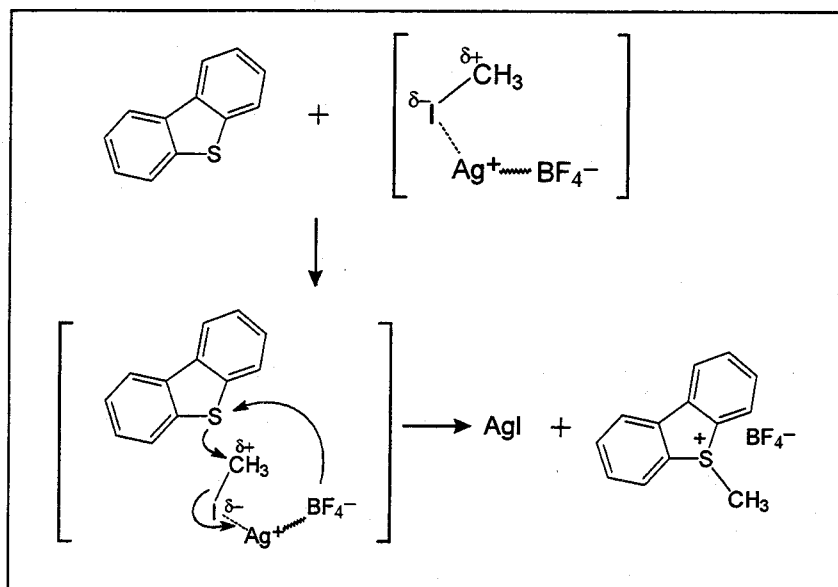

Figure 9-1. Schematic representation of the methylation reaction for DBT with MeI and AgBF₄.

the CH₃I–AgBF₄ complex. Thus when a larger amount of AgBF₄ was added, the sulfur content of the light oil was decreased drastically to less than 0.002 wt%.

The following studies are recommended to extend the results in this work.

(1) Development of the Closed Process for Desulfurization Using Alkylation and Precipitation Techniques

One of the disadvantages in this method, excess quantities of AgBF₄, CH₃I, and CH₂Cl₂ are required for deep desulfurization of light oils. One solution is to recover these materials following desulfurization to be reused for further reaction. Although CH₃I and CH₂Cl₂ remaining in desulfurized light oil can be recovered by evaporation, recovery of AgBF₄ is significantly difficult because the AgBF₄ is dissolved into the CH₂Cl₂ and is thermally unstable. Further study is therefore needed for the development of the closed process. Another solution is to use other methylating agents for desulfurization. Miyatake et al. (1998) have reported that DBT and some alkylsulfides are methylated by the reaction with a strong acid (trifluoromethanesulfonic acid) and esters (methyl formate), to give rise to corresponding sulfonium salts in high yield at room temperature. This approach is probably effective for the development of the closed process.

(2) Utilization of the Thiophenium Salts as Initiators for Cationic Polymerization

Various kind of thiophenium salts have been reported to serve as thermal and photo latent initiators for cationic polymerization (Shimomura et al., 1998a; Saeva et al., 1989). Sulfonium salts derived from less nucleophilic sulfides such as DBT are relatively unstable, thus revealing high initiation activity to the cationic polymerization. Thus, it may be interesting to use the recovered thiophenium salts from light oils by the present desulfurization process, as novel materials for organic syntheses.

(3) Synthesis of the Novel Polymers Having Thiophenium Salt Moieties

The thiophenium salts have been reported to be useful as alkylating agents for transalkylation of olefins (Julia and McDonald, 1991) and cyclization of lactones (Nakamura et al., 1992). In order to utilize the thiophenium salts recovered from the light oils for alkylation, these should to be utilized as polymerized solid materials. Shimomura et al. (1998a; b) have prepared a 2-vinyldibenzothiophene by Ni-catalyzed cross-coupling reaction of vinyl bromide with the Grignard reagent of 2-bromodibenzothiophene, and this was polymerized by the copolymerization with styrene using AIBN to give rise to poly[2-vinyl(dibenzothiophene)]. This was alkylated by the reaction with CH_3I and AgBF_4 to produce a polymer having dibenzothiophenium salt moieties [poly(sulfonium salt)]. If these polymerization techniques are applied to the polymerization of the thiophenium salts recovered from the light oil, useful and functional materials are certainly synthesized.

Literature Cited

- Abu Bakr, S. H. S.; Hamid, H. S.** Removal of Sulfur Compounds from Naphtha Solutions Using Solid Adsorbent. *Chem. Eng. Technol.* **1997**, *20*, 342.
- Acheson, R. M.; Harrison, D. R.** S-Alkylthiophenium Salts. *J. Chem. Soc. D.* **1969**, 724.
- Acheson, R. M.; Harrison, D. R.** The Synthesis, Spectra, and Reactions of Some Alkylthiophenium Salts. *J. Chem. Soc. C.* **1970**, 1764.
- Akasaka, T.; Yabe, A.; Ando, W.** Charge-Transfer Photooxygenation of Sulfides in a Cryogenic Oxygen Matrix: IR Spectroscopic Observation of Persulfoxides. *J. Am. Chem. Soc.* **1987**, *109*, 8085.
- Albro, T. G.; Dreifuss, P. A.; Wormsbecher, R. F.** Quantitative Determination of Sulfur Compounds in FCC Gasolines by AED. A Study of the Effect of Catalyst Type and Catalytic Conditions on Sulfur Distribution. *J. High Resolut. Chromatogr.* **1993**, *16*, 13.
- Amorelli, A.; Amos, Y. D.; Halsig, C. P.; Kosman, J. J.; Jonker, R. J.; De Wind, M.; Vrieling, J.** Estimate Feedstock Processability. Characterize Sulfur Compounds in Middle Distillates and Deeply Hydrogenated Products. *Hydrocarb. Process.*, **1992**, *June*, 93.
- Andersson, J. T.; Bobinger, S.** Polycyclic Aromatic Sulfur Heterocycles. II. Photochemical Oxidation of Benzo[*b*]thiophene in Aqueous Solution. *Chemosphere* **1992**, *24*, 383.
- Andersson, J. T.; Bobinger, S.** Photochemical Degradation of Crude Oil Components: 2-Methyl-, 3-Methyl- and 2,3-Dimethylbenzothiophene. *Polycyclic Aromat. Compd.* **1996**, *11*, 145.
- Attar, A.; Corcoran, W. H.** Desulfurization of Organic Sulfur Compounds by Selective Oxidation. 1. Regenerable and Nonregenerable Oxygen Carriers. *Ind. Eng. Chem. Proc. Des. Dev.* **1978**, *17*, 102.
- Bails, P. J.** "Aromatics-Aliphatics Separation", Chapter. 18·2, *Handbook of Solvent Extraction*, ed. Lo, T. C.; Baird, M. H. I.; Hanson, C.; John Wiley & Sons, New York, 1983.
- Banchereau, E.; Lacombe, S.; Ollivier, J.** Unsensitized Photooxidation of Sulfur Compounds with Molecular Oxygen. *Tetrahedron* **1997**, *53*, 2087.
- Banfield, J. E.; Davis, W.; Gamble, N. W.; Middleton, S. J.** Derivatives of Thianaphthene. Part II. Thianaphthene Derivatives Formed by Cyclization of Acetonyl Aryl Sulfides and Aryl Phenacyl Sulfides. *J. Chem. Soc.* **1956**, 4971.
- Barrett, J.** Photo-Oxidation of Magnesium Porphyrins and Formation of Protobiliviolin. *Nature* **1967**, *215*, 733.

- Beer, R. J. S.; Donavanik, T.; Robertson, A.** Peroxide of Tetrahydrocarbazole and Related Compounds. Part VI. Some Indoleninyl Hydroperoxide. *J. Chem. Soc.* **1954**, 4139.
- Berthou, F.; Vignier, V.** Analysis and Fate of Dibenzothiophene Derivatives in the Marine Environment. *Int. J. Environ. Chem.* **1986**, *27*, 81.
- Bonchio, M.; Campestrini, S.; Conte, V.; Furia, F. D.; Moro, S.** A Theoretical and Experimental Investigation of the Electrophilic Oxidation of Thioethers and Sulfoxides. *Tetrahedron* **1995**, *51*, 12363.
- Bonnet, R.; Brewer, P.; Noro, K.; Noro, T.** Chemistry of Vanadyl Porphyrins. *Tetrahedron* **1978**, *34*, 379.
- Bontempelli, G.; Magno, F.; Mazzocchin, G. A.; Zecchin, S.** Cyclic and A.C. Volumetric Study on Dibenzothiophene in Acetonitrile Medium. *Electroanal. Chem. Interfac. Electrochem.* **1973**, *43*, 337.
- Boukir, A.; Guilliano, M.; Asia, L.; Hallaoui, A. El.; Mille, G.** A Fraction to Fraction Study of Photo-oxidation of BAL 150 Crude Oil Asphaltenes. *Analisis*, **1998**, *26*, 358.
- Calvert, J. G.; Pitts, J. N., Jr.** Photochemistry; Wiley, New York, 1966; 737.
- Chanon, M.; Ebersson, L.** *Photoinduced Electron Transfer*; Fox, M. A. Chanon, M., Eds.; Elsevier: Amsterdam, 1988; Part A, Chapter 1.11.
- Chen, H. -J.; Massoth, F. E.** Hydrodemetalation of Vanadium and Nickel Porphyrins over Sulfided Co/Mo Catalyst. *Ind. Eng. Chem. Res.* **1988**, *27*, 1629.
- Chen, Y.-W.; Hsu, W. C.** Hydrodemetalation of Residue Oil over CoMo/Alumina-Aluminum Phosphate Catalysts in a Trickle Bed Reactor. *Ind. Eng. Chem. Res.* **1997**, *36*, 2526.
- Christensen, H.; Sehested, K.; Corfitzen, H.** Reactions of Hydroxy Radicals with Hydrogen Peroxide at Ambient and Elevated Temperatures. *J. Phys. Chem.* **1982**, *86*, 1588.
- Dexter, D. L.** A Theory of Sensitized Luminescence in Solid. *J. Chem. Phys.* **1953**, *21*, 836.
- Dickie, J. P.; Yen, T. F.** Macrostructure of the Asphaltic Fractions by Various Instrumental Methods. *Anal. Chem.* **1967**, *39*, 1847.
- Didik, B. M.; Alturki, Y. I. A.; Pillinger, C. T.; Eglinton, G.** Petroporphyrins as Indicators of Geochemical Maturation. *Nature* **1975**, *256*, 563.
- Disanzo, F. P.** Characterization of Basic Nitrogen Compounds in Gasolines by Gas Chromatography–Mass Spectrometry. *J. High Resolut. Chromatogr. Chromatogr. Commun.* **1981**, *4*, 649.

- Dong, D.; Jeong, S.; Massoth, F. E.** Effect of Nitrogen Compounds on Deactivation of Hydrotreating Catalysts by Coke. *Catal. Today* **1997**, *37*, 267.
- Dorbon, M.; Bernasconi, C.** Nitrogen Compounds in Light Cycle Oils: Identification and Consequences of Ageing. *Fuel* **1989**, *68*, 1067.
- Drain, C. M.; Gentemann, S.; Roberts, J. A.; Nelson, N. Y.; Medforth, C. J.; Jia, S.; Simpson, M. C.; Smith, K. M.; Fajer, J.; Shelnut, J. A.; Holten, D.** Picosecond to Microsecond Photodynamics of a Nonplanar Nickel Porphyrin: Solvent Dielectric and Temperature Effects. *J. Am. Chem. Soc.* **1998**, *120*, 3781.
- Dunning, H. N.; Moore, J. W.; Denekas, M. O.** Interfacial Activities and Porphyrin Contents of Petroleum Extracts. *Ind. Eng. Chem.* **1953**, *45*, 1759.
- Emery, E. M.** Mass Spectra of Aromatic Esters. *Anal. Chem.* **1960**, *32*, 1495.
- Erdman, J. G.; Ramsey, V. G.; Kalenda, N. W.; Hanson, W. E.** Synthesis and Properties of Porphyrin Vanadium Complex. *J. Am. Chem. Soc.* **1956**, *78*, 5844.
- Eriksen, J.; Foote, C. S.** Electron-Transfer Fluorescence Quenching and Exciplexes of Cyano-Substituted Anthracene. *J. Phys Chem.* **1978**, *82*, 2959.
- Eriksen, J.; Foote, C. S.; Parker, T. L.** Photosensitized Oxygenation of Alkenes and Sulfide via a Non-Singlet-Oxygen Mechanism. *J. Am. Chem. Soc.* **1977**, *99*, 6455.
- Fields, E. K.; Meyersson, S.** Pyrolysis and Mass Spectrum of Dibenzothiophene-5,5-Dioxide. *J. Am. Chem. Soc.* **1966**, *88*, 2836.
- Foote, C. S.** Mechanisms of Photosensitized Oxidation. *Science* **1968**, *162*, 3857.
- Freeman, D. H.; Swahn, I. D.; Hambright, P.** Spectrophotometry and Solubility Properties of Nickel and Vanadyl Porphyrin Complexes. *Energy & Fuels* **1990**, *4*, 699.
- Fujishiro, M.; Ohta, K.; Iwai, S.** Influence of Light Irradiation on Asphalt Components. *J. Jpn. Petrol. Inst.* **1979**, *22*, 319.
- Gallagher, J. R.; Olson, E. S.; Stanley, D. C.** Microbial Desulfurization of Dibenzothiophene: A Sulfur Specific Pathway. *FEMS Microbiol. Lett.* **1993**, *107*, 31.
- Gary, J. H.; Handwerk, G. E.** *Petroleum Refining. Technology and Economics*, 2nd ed.: Marcel Dekker: New York, 1984.
- Gerdil, R.; Lucken, E. A. C.** The Electron Spin Resonance Spectra of the Dibenzothiophene Radical Anion and Its Isologs and the Electronic Structure of Conjugated Sulfur-Containing Heterocycles. *J. Am. Chem. Soc.* **1965**, *87*, 213.
- Gerdil, R.; Lucken, E. A. C.** Polarographic and Spectroscopic Study of Dibenzothiophene and Some of Its Isologs. *J. Am. Chem. Soc.* **1966**, *88*, 733.
- Gessner, F.; Scaiano, J. C.** Importance of Entropy Terms in Triplet Energy Transfer Equilibria. *J. Am. Chem. Soc.* **1985**, *107*, 7206.

- Gilman, H.; Esmay, D. L.** The Oxidation of Dibenzothiophene and Phenoxathiin with Hydrogen Peroxide. *J. Am. Chem. Soc.* **1952**, *74*, 2021.
- Girgis, M. J.; Gates, B. C.** Reactivities, Reaction Networks, and Kinetics in High-Pressure Catalytic Hydroprocessing. *Ind. Eng. Chem. Res.* **1991**, *30*, 2021.
- Gregory, D. D.; Wan, Z.; Jenks, W. S.** Photodeoxygenation of Dibenzothiophene Sulfoxide: Evidence for a Unimolecular S-O Cleavage Mechanism. *J. Am. Chem. Soc.* **1997**, *119*, 94.
- Gutberlet, L. C.; Bertolacini, R. J.** Inhibition of Hydrodesulfurization by Nitrogen Compounds. *Ind. Eng. Chem. Process Des. Dev.* **1984**, *23*, 179.
- Hannoun, M.; Blazevic, N.; Kolbah, D.; Mihalic, M.; Kajfez, F.** α -Phenylpropionic Acid Derivatives. Synthesis and Dethiation of 5-Benzoylbenzo[*b*]thiophene-3-Carboxylic Acid. *J. Heterocycl. Chem.* **1982**, *19*, 1131.
- Hanson, G.; Kemp, D. S.** Convenient Routes to 4,4''-Functionalized *o*-Terphenyls and 2,2'-Functionalized Biphenyls. *J. Org. Chem.* **1981**, *46*, 5441.
- Harriman, A.** Luminescence of Porphyrins and Metallo Porphyrins. Part 1. -Zinc(II), Nickel(II) and Manganese(II) Porphyrins. *J. Chem. Soc. Faraday Trans. 1.* **1980**, *76*, 1978.
- Hatanaka, S.; Yamada, M.; Sadakane, O.** Hydrodesulfurization of Catalytic Cracked Gasoline. 1. Inhibiting Effects of Olefins on HDS of Alkyl(benzo)thiophenes Contained in Catalytic Cracked Gasoline. *Ind. Eng. Chem. Res.* **1997a**, *36*, 1519.
- Hatanaka, S.; Yamada, M.; Sadakane, O.** Hydrodesulfurization of Catalytic Cracked Gasoline. 2. The Difference between HDS Active Site and Olefin Hydrogenation Active Site. *Ind. Eng. Chem. Res.* **1997b**, *36*, 5110.
- Heimlich, B. N.; Wallace, T. J.** Kinetics and Mechanism of the Oxidation of Dibenzothiophene in Hydrocarbon Solution. Oxidation by Aqueous Hydrogen Peroxide-Acetic Acid Mixtures. *Tetrahedron* **1966**, *22*, 3571.
- Hendry, D. G.; Gould, C. W.; Schuetzle, D.; Syz, M. G.; Mayo, F. R.** Autoxidations of Cyclohexane and Its Autoxidation Products. *J. Org. Chem.* **1976**, *41*, 1.
- Hershberger, M. V.; Lumry, R. W.; Verrall, R.** The 3-Methylindole/*n*-Butanol Exciplexes: Evidence for Two Exciplex Sites in Indole Compounds. *Photochem. Photobiol.* **1981**, *34*, 609.
- Hirai, T.; Ogawa, K.; Komasa, I.** Desulfurization Process for Dibenzothiophenes from Light Oil by Photochemical Reaction and Liquid-Liquid Extraction. *Ind. Eng. Chem. Res.* **1996**, *35*, 586.
- Houalla, M.; Broderick, D. H.; Sapre, A. V.; Nag, N. K.; J. De Beer, V. H.; Gates, B. C.; Kwart, H.** Hydrodesulfurization of Methyl-Substituted Dibenzothiophenes Catalyzed by Sulfided Co-Mo/ γ -Al₂O₃. *J. Catal.* **1980**, *61*, 523.

- Hung, C. -W.; Wei, J.** The Kinetics of Porphyrin Hydrodemetalation. 2. Vanadyl Compounds. *Ind. Eng. Chem. Process Des. Dev.* **1980**, *19*, 257.
- Ingram, D. J. E.; Hodgson, W. G.; Parker, C. A.; Rees, W. T.** Detection of Labile Photochemical Free Radicals by Paramagnetic Resonance. *Nature*, **1955**, *176*, 1227.
- Jacquot, F.; Guiliano, M.; Doumenq, P.; Munoz, D.; Mille, G.** In Vitro Photooxidation of Crude Oil Maltenic Fractions: Evolution of Fossil Biomarkers and Polycyclic Aromatic Hydrocarbons. *Chemosphere* **1996**, *33*, 671.
- Jenks, W. S.; Lee, W.; Shutters, D.** Photochemistry of Aromatic Sulfoxides. 1. Characterization of the Triplets at Cryogenic Temperatures. *J. Phys. Chem.* **1994a**, *98*, 2282.
- Jenks, W. S.; Taylor, L. M.; Guo, Y.; Wan, Z.** Photochemistry of Dibenzothiophene-S,S-dioxide: Reactions of a Highly Constrained Biradical. *Tetrahedron Lett.* **1994b**, *35*, 7155.
- Jeoung, S. C.; Kim, D.; Hahn, S. J.; Ryu, S. Y.; Yoon, M.** Lowest Excited State of Oxovanadyl(IV)Tetraphenylporphyrin. *J. Phys. Chem. A* **1998**, *102*, 315.
- Jones, A. C.; Dale, M. J.; Keenan, G. A.; Langridge-Smith, P. R. R.** Photoionization and Photodissociation of Laser-Vaporised Metallotetraphenylporphyrins. *Chem. Phys. Lett.* **1994**, *219*, 174.
- Julia, M.; McDonald, B.** Biomimetic Transalkylation of Olefins via Sulfonium Salts. *Tetrahedron* **1991**, *47*, 6939.
- Kabe, T.; Ishihara, A.; Tajima, H.** Hydrodesulfurization of Sulfur-Containing Polyaromatic Compounds in Light Oil. *Ind. Eng. Chem. Res.* **1992**, *31*, 1577.
- Kameyama, H.; Sugishima, M.; Yamada, M.; Amano, A.** Hydrodevanadization of Vanadyl Porphyrin by Tetrarin. *J. Jpn. Petrol. Inst.* (in Japanese) **1981**, *24*, 317.
- Katzer, J. R.; Sivasubramanian, R.** Process and Catalyst Need for Hydrodenitrogenation. *Catal. Rev. -Sci. Eng.* **1979**, *20*, 155.
- Kearns, D. R.** Physical and Chemical Properties of Singlet Molecular Oxygen. *Chem. Rev.* **1971**, *71*, 395.
- Kira, A.; Thomas, J. K.** Equilibria between Triplet States of Aromatic Hydrocarbons. *J. Phys. Chem.* **1974**, *78*, 196.
- Kirkland, J. J.** Analysis of Sulfonic Acids and Salts by Gas Chromatography of Volatile Derivatives. *Anal. Chem.* **1960**, *32*, 1388.
- Kuehm-Caubère, C.; Adach-Becker, S.; Fort, Y.; Caubère, P.** Expedient and Efficient Syntheses of Pure 4-Methyl and 4,6-Disubstituted Dibenzothiophenes. *Tetrahedron* **1996**, *52*, 9087.
- Larson, R. A.; Bott, T. L.; Hunt, L. L.; Rogenmuser, K.** Photooxidation Products of a Fuel Oil and Their Antimicrobial Activity. *Environ. Sci. Technol.* **1979**, *13*, 965.

- Lee, B.** Highlights of the Clean Air Act Amendments of 1990. *J. Air Waste Manage. Assoc.* **1991**, *41*, 16.
- Liang, J. J.; Gu, C. -L.; Kacher, M. L.; Foote, C. S.** Chemistry of Singlet Oxygen. 45. Mechanism of the Photooxidation of Sulfides. *J. Am. Chem. Soc.* **1983**, *105*, 4717.
- Lin, S. H.; Chen, Y. W.** Liquid Adsorption of 1,1-Dichloro-1-fluoroethane by Various Adsorbents. *Ind. Eng. Chem. Res.* **1997**, *36*, 4347.
- Linguist, L.; Pacheco, M.** Enzyme-Based Diesel Desulfurization Process Offers Energy, CO₂ Advantages. *Oil Gas J.* **1999**, *Feb*, 45.
- Mao, J.; Pacheco, C. R.; Traficante, D. D.; Rosen, W.** Identification and Characterization of Nitrogen Compounds in Brazilian Diesel Oil by Particle Beam LC-MS. *Fuel* **1995**, *74*, 880.
- Mattes, S. L.; Farid, S.** Photochemical Cycloadditions via Exciplexes, Excited Complexes, and Radical Ions. *Acc. Chem. Res.* **1982**, *15*, 80.
- Mclafferty, F. W.; Gohlke, R. S.** Mass Spectrometric Analysis. Aromatic Acids and Esters. *Anal. Chem.* **1959**, *31*, 2076.
- Mill, T.; Mabey, W. R.; Lan, B. Y.; Baraze, A.** Photolysis of Polycyclic Aromatic Hydrocarbons in Water. *Chemosphere* **1981**, *10*, 1281.
- Miyatake, K.; Yamamoto, K.; Endo, K.; Tsuchida, E.** Superacidified Reaction of Sulfides and Esters for the Direct Synthesis of Sulfonium Derivatives. *J. Org. Chem.* **1998**, *63*, 7522.
- Mizuno, K.; Kamiyama, N.; Ichinose, N.; Otsuji, Y.** Photo-oxygenation of 1,2-Diarylcyclopropanes via Electron Transfer. *Tetrahedron* **1985**, *41*, 2207.
- Monticello, D. J.** Biocatalytic Desulfurization. The Refining of Petroleum Fractions. *Hydrocarbon Process.*, **1994**, *Feb*, 39.
- Moza, P. N.; Hustert, K.; Loeff, S.** Photochemical Transformations of Selected Organic Chemicals in Two Phase System. *Toxicol. Environ. Chem.* **1991**, *31-32*, 103.
- Murov, S. L.; Carmichael, I.; Hug, G. L.** *Handbook of Photochemistry, Second Edition*; Marcel Dekker: New York, 1993.
- Nakamura, T.; Matsuyama, H.; Kamigata, N.; Iyoda, M.** Synthesis of Macrocyclic Dilactones by Cyclization of Sulfonium Salts. *J. Org. Chem.* **1992**, *57*, 3783.
- Natusch, D. F. S.; Tomkins, B. A.** Isolation of Polycyclic Organic Compounds by the Solvent Extraction with Dimethyl Sulfoxide. *Anal. Chem.* **1978**, *50*, 1429.
- Ogawa, K.** Desulfurization Process of Light Oil by Photochemical Reaction and Liquid-Liquid Extraction. MSc Thesis, Osaka Univ. **1996**.
- Olson, E. S.; Stanley, D. C.; Gallagher, J. R.** Characterization of Intermediates in the Microbial Desulfurization of Dibenzothiophene. *Energy & Fuels* **1993**, *7*, 159.

- Omura, K.; Matsuura, T.** Photoinduced Reactions-IX. The Hydroxylation of Phenols by the Photodecomposition of Hydrogen Peroxide in Aqueous Media. *Tetrahedron* **1968**, *24*, 3475.
- Omura, K.; Matsuura, T.** Photoinduced Reactions-XXXV. The Hydroxylation of Phenols by the Photodecomposition of Hydrogen Peroxide in Acetonitrile. *Tetrahedron* **1970**, *26*, 255.
- Ono, T.** Rapid Method for Determination of Asphaltene Content in Residual Fuel Oils. *J. Jpn. Petrol. Inst.* (in Japanese) **1971**, *14*, 504.
- Papa, D.; Schenk, E.; Ginsberg, H.** Reductions with Nickel-Aluminum Alloy and Aqueous Alkali. Part VII. Hydrogenolysis of Sulfur Compounds. *J. Org. Chem.* **1949**, *14*, 727.
- Picel, K. C.; Simmons, M. S.; Stamoudis, V.** Sunlight Photolysis of Selected Indoles and Carbazole in Aqueous Coal-Oil Systems. *ACS Symp. Ser.* **1987**, *327*, 45.
- Quimby, B. D.; Grudoski, D. A.; Giarrocco, V.** Improved Measurement of Sulfur and Nitrogen Compounds in Refinery Liquids Using Gas Chromatography-Atomic Emission Detection. *J. Chromatogr. Sci.* **1998**, *36*, 435.
- Reinecke, M. G.; Newsom, J. G.; Chen, L. -J.** Thermolysis of Thiophenedicarboxylic Acid Anhydrides as a Route to Five Membered Hetarynes. *J. Am. Chem. Soc.* **1981**, *103*, 2760.
- Rehm, D.; Weller, A.** Kinetics of Fluorescence Quenching by Electron and H-Atom Transfer. *Isr. J. Chem.* **1970**, *8*, 259.
- Reynolds, J. G.; Gallegos, E. J.; Fish, R. H.; Komlenic, J. J.** Characterization of the Binding Sites of Vanadium Compounds in Heavy Crude Petroleum Extracts by Electron Paramagnetic Spectroscopy. *Energy & Fuels* **1987**, *1*, 36.
- Rhodes, A. K.** Enzyme Desulfurizing Diesel Fuel in Pilot Plant Tests. *Oil Gas J.* **1995**, *May*, 39.
- Saeva, F. D.; Breslin, D. T.; Martic, P. A.** The Effect of the Nature of the Lowest Unoccupied Molecular Orbital (LUMO) of Some Arylmethylsulfonium Salt Derivatives on Photochemical and Redox behavior. *J. Am. Chem. Soc.* **1989**, *111*, 1328.
- Saraceno, A. J.; Fanale, D. T.; Coggeshell, N. D.** An Electron Paramagnetic Resonance Investigation of Vanadium in Petroleum Oils. *Anal. Chem.* **1961**, *33*, 500.
- Seely, G. R.; Calvin, M.** Photochemical Studies of the Porphyrins. III. Photoreduction of a Porphyrin by Benzoin. *J. Chem. Phys.* **1955**, *23*, 1068.
- Selbin, J.** The Chemistry of Oxovanadium(IV). *Chem. Rev.* **1965**, *65*, 2.
- Shimomura, O.; Sato, T.; Tomita, I.; Endo, T.** S-Alkyldibenzothiophenium Salts as New Thermal Latent Cationic Initiators. *Macromolecules* **1998a**, *31*, 2013a.

- Shimomura, O.; Sato, T.; Tomita, I.; Suzuki, M.; Endo, T.** Synthesis and Properties of Novel Polymers Having Methyldibenzothiophenium Salt Moieties. *J. Polym. Sci., Part A: Polym. Chem.* **1998b**, *36*, 1779.
- Shimomura, O.; Sato, T.; Tomita, I.; Suzuki, M.; Endo, T.** Synthesis and Radical Polymerization of 2-Vinyldibenzothiophene. **1997**, *35*, 2813.
- Srogl, J.; Janda, M.; Stibor, I.; Kos, J.; Vyskocil, V.** Electrochemical Oxidation of Benzothiophenes. *Collect. Czech. Chem. Commun.* **1978**, *43*, 2015.
- Still, I. W. J.** Photochemistry of Sulfoxides and Sulfones. In *The Chemistry of Sulphones and Sulphoxides*; Paul, S., Rappoport, Z., Stirling, C., Eds.; John Wiley & Sons: New York, 1988; Chapter 18.
- Tajima, H.; Kabe, T.; Ishihara, A.** Separation and Analysis of Sulfur-Containing Polyaromatic Hydrocarbons in Light Oil (in Japanese). *Bunseki Kagaku* **1993**, *42*, 67.
- Taylor, S. E.** Investigations into the Electrical and Coalescence Behaviour of Water-in-Crude Oil Emulsions in High Voltage Gradients. *Colloid Surf.* **1988**, *29*, 29.
- Terenin, A.; Ermolaev, V.** Sensitized Phosphorescence in Organic Solutions at Low Temperature. *Trans. Faraday Soc.* **1956**, *52*, 1042.
- Tezuka, T.; Miyazaki, H.; Suzuki, H.** On the Photo-Oxidation of Sulfides in the Presence of Oxygen. *Tetrahedron Lett.* **1978**, *22*, 1959.
- Tsai, M. -C.; Chen, Y. -W.; Kang, B. -C.; Wu, J. C.; Leu, L. J.** Hydrodesulfurization and Hydrodemetalation Reactions of Residual Oils over CoMo/Alumina Borate Catalysts in a Trickle Bed Reactor. *Ind. Eng. Chem. Res.* **1991**, *30*, 1801.
- Turro, N. J.** Molecular photochemistry: Benjamin: New York, 1965.
- Tynan, E. C.; Yen, T. F.** Association of Vanadium Chelates in Petroleum Asphaltenes as Studied by ESR. *Fuel* **1969**, *43*, 191.
- Upton, L. L.; Schnaith, M. W.** Low-Sulfur Specifications Cause Refiners to Look at Hydrotreating Options. *Oil Gas J.* **1997**, *Dec*, 47.
- Verne-Mismer, R.; Ocampo, R.; Bauder, C.; Callot, H. J.; Albrecht, P.** Structural Comparison of Nickel, Vanadyl, Copper, and Free Base Porphyrins from Oulad Abdoum Oil Shale (Maastrichtian, Morocco). *Energy & Fuels* **1990**, *4*, 639.
- Vignier, V.; Berthou, F.; Picart, D.** Influence of Injection Systems on the Gas Chromatographic Analysis of Oxygenated Dibenzothiophenes. *J. High. Resolut. Chromatogr. Chromatogr. Commun.* **1983**, *6*, 661.
- Volman, D. H.; Chen, J. C.** The Photochemical Decomposition of Hydrogen Peroxide in Aqueous Solutions of Allyl Alcohol at 2537 Å. *J. Am. Chem. Soc.* **1959**, *81*, 4141.
- Wan, Z.; Jenks, W. S.** Oxenoid Reactivity Observed on the Photolysis of Certain Aromatic Sulfoxide. *J. Am. Chem. Soc.* **1995**, *117*, 2667.
- Werner, E. G. G.** Synthesis of Benzothiophenes. *Recl. Trav. Chim.* **1949**, *68*, 509.

- Yamada, Y.; Koinuma, Y.** Behavior of Vanadyl Chelate Complexes in GPC Fractionated Asphaltenes. *J. Jpn. Petrol. Inst.* (in Japanese) **1989**, *32*, 7.
- Yamaji, M.; Okada, K.; Marcinak, B.; Shizuka, H.** Laser Photolysis Studies on Triplet-Equilibrium Formation in a Small Triplet-Energy Gap System. *Chem. Phys. Lett.* **1997**, *277*, 375.
- Yen, T. F.; Bougher, L. J.; Dickie, J. P.; Tynan, E. C.; Vaughan, G. B.** Vanadium Complexes and Porphyrins in Asphaltenes. *J. Inst. Petrol.* **1969**, *55*, 87.
- Zannikos, F.; Lois, E.; Stournas, S.** Desulfurization of Petroleum Fractions by Oxidation and Solvent Extraction. *Fuel Process. Technol.* **1995**, *42*, 35.

List of Publication

Papers:

- (1) Hirai, T.; Shiraishi, Y.; Komasaawa, I. Desulfurization Process for Light Oil by Photochemical Reaction and Liquid-Liquid Extraction: Removal of Benzothiophenes and Alkyl Sulfides. *J. Chem. Eng. Jpn.* **1997**, *30*, 171-173.
- (2) Hirai, T.; Shiraishi, Y.; Ogawa, K.; Komasaawa, I. Effect of Photosensitizer and Hydrogen Peroxide on Desulfurization of Light Oil by Photochemical Reaction and Liquid-Liquid Extraction. *Ind. Eng. Chem. Res.* **1997**, *36*, 530-533.
- (3) Shiraishi, Y.; Hirai, T.; Komasaawa, I. A Deep Desulfurization Process for Light Oil by Photochemical Reaction in an Organic Two-Phase Liquid-Liquid Extraction System. *Ind. Eng. Chem. Res.* **1998**, *37*, 203-211.
- (4) Shiraishi, Y.; Taki, Y.; Hirai, T.; Komasaawa, I. Visible Light-Induced Desulfurization Technique for Light Oil. *Chem. Commun.* **1998**, 2601-2602.
- (5) Shiraishi, Y.; Hirai, T.; Komasaawa, I. Photochemical Desulfurization of Light Oils Using Oil/Hydrogen Peroxide Aqueous Solution Extraction System: Application for High Sulfur Content Straight-Run Light Gas Oil and Aromatic Rich Light Cycle Oil. *J. Chem. Eng. Jpn.* **1999**, *32*, 158-161.
- (6) Shiraishi, Y.; Hirai, T.; Komasaawa, I. Photochemical Desulfurization of Methyl-Substituted Organic Sulfur Compounds From Light Oil Using an Oil/Hydrogen Peroxide Aqueous Solution System. *Solv. Extr. Res. Dev. Jpn.* **1999**, *6*, 137-143.
- (7) Shiraishi, Y.; Hara, H.; Hirai, T.; Komasaawa, I. A Deep Desulfurization Process for Light Oil by Photosensitized Oxidation Using a Triplet Photosensitizer and Hydrogen Peroxide in an Oil/Water Two-Phase Liquid-Liquid Extraction System. *Ind. Eng. Chem. Res.* **1999**, *38*, 1589-1595.
- (8) Shiraishi, Y.; Hirai, T.; Komasaawa, I. Identification of Desulfurization Products in the Photochemical Desulfurization Process for Benzothiophenes and Dibenzothiophenes from Light Oil Using an Organic Two-Phase Extraction System. *Ind. Eng. Chem. Res.* **1999**, *38*, 3300-3309.
- (9) Shiraishi, Y.; Taki, Y.; Hirai, T.; Komasaawa, I. Visible Light-Induced Deep Desulfurization Process for Light Oils by Electron-Transfer Oxidation in an Organic Two-Phase Extraction System. *Ind. Eng. Chem. Res.* **1999**, *38*, 3310-3318.

- (10) **Shiraishi, Y.; Taki, Y.; Hirai, T.; Komasaawa, I.** Visible Light-Induced Desulfurization Process for Catalytic-Cracked Gasoline by Photochemical Electron-Transfer Oxidation in an Organic Two-Phase Extraction System. *Ind. Eng. Chem. Res.* **1999**, *38*, 4538–4544.
- (11) **Shiraishi, Y.; Hirai, T.; Komasaawa, I.** Photochemical Desulfurization for Light Cycle Oil Using an Organic Two-Phase Extraction System. *Solv. Ext. Res. Dev. Jpn.* **2000**, *7*, in press.
- (12) **Shiraishi, Y.; Hirai, T.; Komasaawa, I.** Novel Deep Desulfurization Processes for Fuel Oils by Photochemical Reaction and Liquid–Liquid Extraction (in Japanese). *Kagaku Kogaku Ronbunshu*, **2000**, *26*, in press.
- (13) **Shiraishi, Y.; Hirai, T.; Komasaawa, I.** A Novel Demetalation Process for Vanadyl and Nickelporphyrins from Petroleum Residue by Photochemical Reaction and Liquid–Liquid Extraction. *Ind. Eng. Chem. Res.* **2000**, *39*, in press.
- (14) **Shiraishi, Y.; Hirai, T.; Komasaawa, I.** Photochemical Denitrogenation Process for Light Oils Effected by Combination of UV Irradiation and Liquid–Liquid Extraction. *Ind. Eng. Chem. Res.* submitted.
- (15) **Shiraishi, Y.; Taki, Y.; Hirai, T.; Komasaawa, I.** A Novel Methodology Towards Deep Desulfurization of Light Oil Effected by Sulfonium Salts Formation. *Chem. Commun.* submitted.

Proceedings:

- (1) **Shiraishi, Y.; Hirai, T.; Komasaawa, I.** Novel Deep Desulfurization Processes for Light Oils by Photochemical Reaction and Liquid–Liquid Extraction. (in Japanese) *Chem. Eng. Symp. Ser.* **1998**, *63*, 98–107.
- (2) **Shiraishi, Y.; Hirai, T.; Komasaawa, I.** New Desulfurization Process for Light Oil by Photochemical Reaction and Liquid–Liquid Extraction (in Japanese). *Chemical Engineering* **1998**, *43*, 610–615.
- (3) **Shiraishi, Y.; Hirai, T.; Komasaawa, I.** A Deep Desulfurization Process for Light Oil by Photochemical Reaction in an Organic Two-Phase Liquid–Liquid Extraction System. *Proc. Int. Solv. Extr. Conf. (ISEC '99)* **1999**, in press.

Acknowledgment

The author is greatly indebted to Professor Dr. Isao Komasaawa and Associate Professor Dr. Takayuki Hirai (Department of Chemical Science and Engineering, Graduate School of Engineering Science, Osaka University) for their constant guidance and helpful advice throughout this work. The author is sincerely grateful to Professor Dr. Shun-ichi Murahashi, Professor Dr. Yoshito Tobe, and Professor Dr. Yushi Hirata (Graduate School of Engineering Science, Osaka University) for a number of valuable comments and criticisms during the completion of this thesis.

The author is also grateful to Professor Dr. Kiyotomi Kaneda and Dr. Tomoo Mizugaki (Graduate School of Engineering Science, Osaka University) for synthesis of 4-methyl and 4,6-dimethyl dibenzothiophenes, Dr. Akio Furuta and Yoshio Harada (JGC Corporation) for analysis of nitrogen content of light oils and GC-AED analysis of sulfur-containing compounds, and Mr. Masayuki Yanagisawa (Shimadzu Co. Ltd.) for analysis of sulfate anion and maintenance of HPLC. The author is grateful to Dr. Hiroshi Sato for his helpful advises and discussions.

The author acknowledges Drs. Akira Hino, Susumu Shiojiri, Makoto Yoshimoto, and Mr. Ken Ogawa for their kind encouragement and advice and also other members at the same laboratory for their friendship. Special thanks are given to the following colleagues for their experimental cooperation: Messrs. Yasuto Taki, Kenya Tachibana, and Hiroyuki Hara. The author also wishes to thank his parents Tetsuya Shiraishi and Miwako Shiraishi, and his younger sister Tomoko Shiraishi for their continuous encouragement and supports, and Chiaki Nakamori for her hearty encouragement. The author gratefully acknowledges the Morishita Jintan Scholarship foundation.

This study was supported financially by the Research Fellowship of the Japan Society for the Promotion and Science for Young Scientists and by Showa Schell Sekiyu Foundation for Promotion of Environmental Research.