

Title	Evaluation Technique of the Director Alignment in Liquid-Crystal Cell by Elastic Waves
Author(s)	Inoue, Masaru; Yoshino, Katsumi; Moritake, Hiroshi et al.
Citation	電気材料技術雑誌. 2001, 10(2), p. 95-98
Version Type	VoR
URL	<a href="https://hdl.handle.net/11094/81668">https://hdl.handle.net/11094/81668</a>
rights	
Note	

*Osaka University Knowledge Archive : OUKA*

<https://ir.library.osaka-u.ac.jp/>

Osaka University

## Evaluation Technique of the Director Alignment in Liquid-Crystal Cell by Elastic Waves

Masaru Inoue and Katsumi Yoshino

*Department of Electronic Engineering, Graduate School of Engineering  
Osaka University, 2-1 Yamadaoka, Suita, Osaka 565-0871, Japan*

Hiroshi Moritake and Kohji Toda

*Department of Electrical and Electronic Engineering, National Defense Academy,  
1-10-20 Hashirimizu, Yokosuka, Kanagawa 239-8686, Japan*

The behaviors of liquid-crystal directors at an interface between a liquid-crystal layer and a glass plate are of practical importance from the viewpoints of fabrication of a liquid-crystal device such as liquid-crystal display (LCD) and physical interest. Alignment of the liquid crystal is a key factor for LCD, and many methods have been employed to study the liquid-crystal alignment [1-3]. Measurements of attenuated total internal reflection and pretransitional optical birefringence are effective for investigating the director orientation near the solid/liquid-crystal interface. Optical second harmonic generation (SHG) [4], total reflection ellipsometry (TRE) [5] and scanning tunneling microscope (STM) [6] have been increasingly examined for detecting the behavior of liquid-crystal director in the vicinity of the solid/liquid-crystal interface. These methods have been used for investigating liquid-crystal director alignment in the liquid-crystal cell, however, convenient methods without complicated experimental setup have been desired.

In this study, the method for evaluating the director-orientation in the liquid crystal cell using two different types of elastic wave propagation. The acoustic phase-delays of the shear horizontal (SH) wave and the Lamb wave in the liquid-crystal cell are measured. The propagation characteristics of the both waves in the liquid-crystal cell are numerically analyzed. The director orientations in the liquid-crystal cell are evaluated by the both elastic waves having different vibration-displacement profiles.

Figure 1 shows a schematic construction of the elastic wave device prepared for the experimental study. Two interdigital transducers (IDTs) are mounted on a piezoelectric ceramic plate cemented on a glass plate. Each of the IDTs has an interdigital periodicity of 400  $\mu\text{m}$  and seven electrode-finger pairs. A liquid-crystal layer, located at the central position of the elastic wave device, is sandwiched between two 400- $\mu\text{m}$ -thick glass plates (Corning, 7059) coated with In-Sn oxide (ITO). The thickness of the liquid-crystal layer is 25  $\mu\text{m}$ , adjusted by a PET film as the spacer.

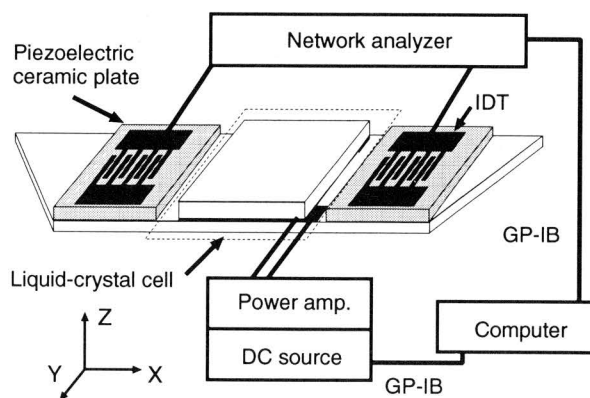
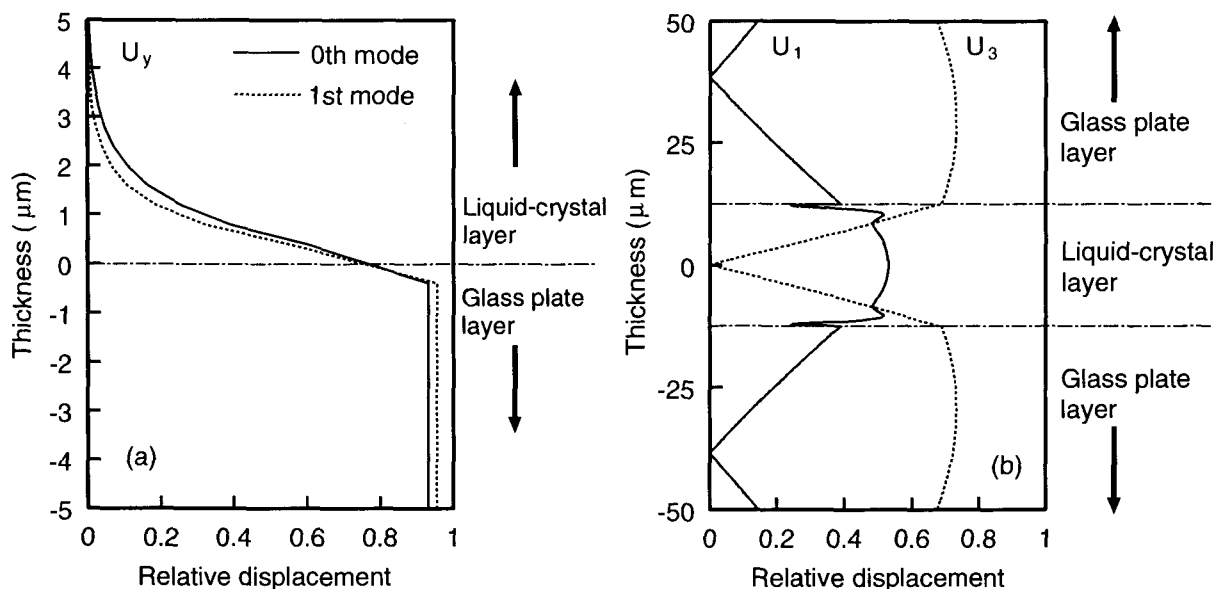

Fig.1 Schematic construction of the device.

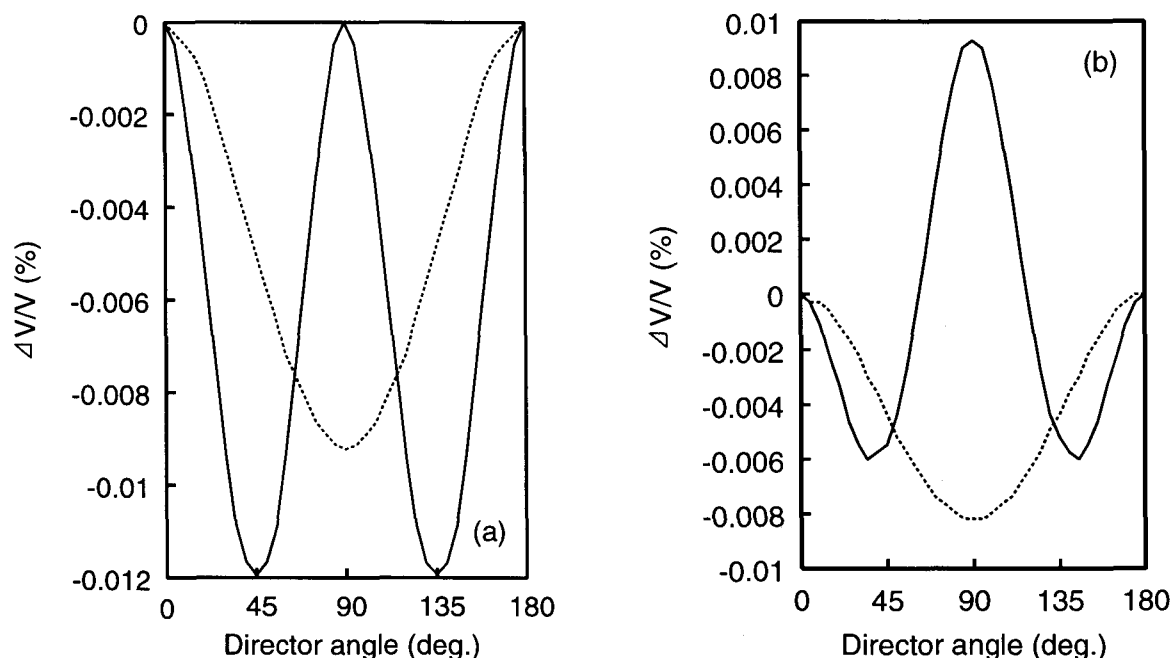

**Fig.2** Mechanical displacement distributions of (a) SH wave and (b) Lamb wave.

The tested liquid-crystal sample is 5CB with positive dielectric anisotropy. In the above construction, a dc electric field is applied to the liquid-crystal layer between two glass plates. The SH wave and the Lamb wave generated at one of the two IDTs propagate into a liquid-crystal cell sandwiched by the two glass plates. The inner surfaces of the two glass plates are coated with a polyimide (JSR, AL1254) film and rubbed along the  $X$ -axis or the  $Y$ -axis. The propagation direction and the vibration-displacement direction of the SH wave are along the  $X$ - and  $Y$ -axes, respectively. The vibration-displacement direction of the Lamb wave is in the  $X$ - $Z$  plane and the propagation direction is along the  $X$ -axis. The acoustic phase-delay of the SH wave and the Lamb wave propagating between the two IDTs are measured by a network analyzer (HP, 4195A).

The propagation characteristics of the SH wave and the Lamb wave in the liquid-crystal cell layer are numerically analyzed. Figures 2 (a) and (b) show the calculated mechanical displacement distributions of the SH wave and the Lamb wave, respectively. The mechanical displacements of the SH wave completely decay in the liquid-crystal layer at about  $3 \mu\text{m}$  from the interface. It is supported by the fact that the shear wave decays exponentially in the viscous liquid environment [7]. On the other hand, the compressional component  $U_x$  of the mechanical displacement of the Lamb wave exists in the entire region of the liquid-crystal cell although the shear vertical component  $U_z$  decays in the liquid-crystal cell. The result means that the longitudinal wave can propagate in the liquid environment. The phase velocities of the SH and Lamb waves are considered to be affected by the entire region of the liquid-crystal director.

Figure 3 (a) shows the calculated director angle dependences of the fractional velocity change of the SH wave. The real and dotted lines correspond to the rotation of the director in the  $Z$ - $Y$  and  $Z$ - $X$  planes, respectively. The fractional velocity change of the director angle of the real line takes the minimum value at 45 degrees. On the contrary, the curve indicated by the dotted line takes the minimum value at 90 degrees.



**Fig.3** Director angle dependence of  $\Delta V/V$  of (a) SH wave and (b) Lamb wave.

Figure 3 (b) shows the calculated director angle dependences of the fractional velocity change of the 6th mode Lamb wave. The period of  $\Delta V/V$  of the director angle in the case of real line is three times shorter than that in the case of dotted line. This result is considered to be affected by the compressional component of the Lamb wave propagation. The director angle dependences of the fractional velocity change of the SH wave and the Lamb wave indicate that the phase velocities of these waves are much affected by the director orientation of the nematic liquid crystal.

An applied voltage dependence of the acoustic phase-delay is measured by the system shown in Fig. 1. The director angle is related to the measured acoustic phase-delay, which leads to the evaluation of the director angle. Figures 4 (a) and (b) show the applied voltage dependences of the director angle in the liquid-crystal cell using the SH wave and the Lamb wave, respectively. Evaluated applied electric field dependences 0th and 1st modes of the SH wave in Fig. 4 (a). The liquid-crystal director angle increases abruptly by the application of low electric field. The penetration depth is understandable from the mechanical displacement distribution of the SH wave, as shown in Fig. 2 (a) In this experiment, the evaluated director angle is regarded as the average angle of the directors existing in the region from the interface to the depth of the order of a few micrometers. Evaluated applied electric field dependences by 6th mode Lamb wave propagation in Fig. 4 (b). The liquid-crystal director angle increases abruptly by the application of low electric field as well as the result under the SH wave propagation, however, the evaluated director angles are different from those of the SH wave. The difference of the evaluated director angle between the SH wave and the Lamb wave propagation is caused by the mechanical displacement distributions of two kinds of elastic waves.

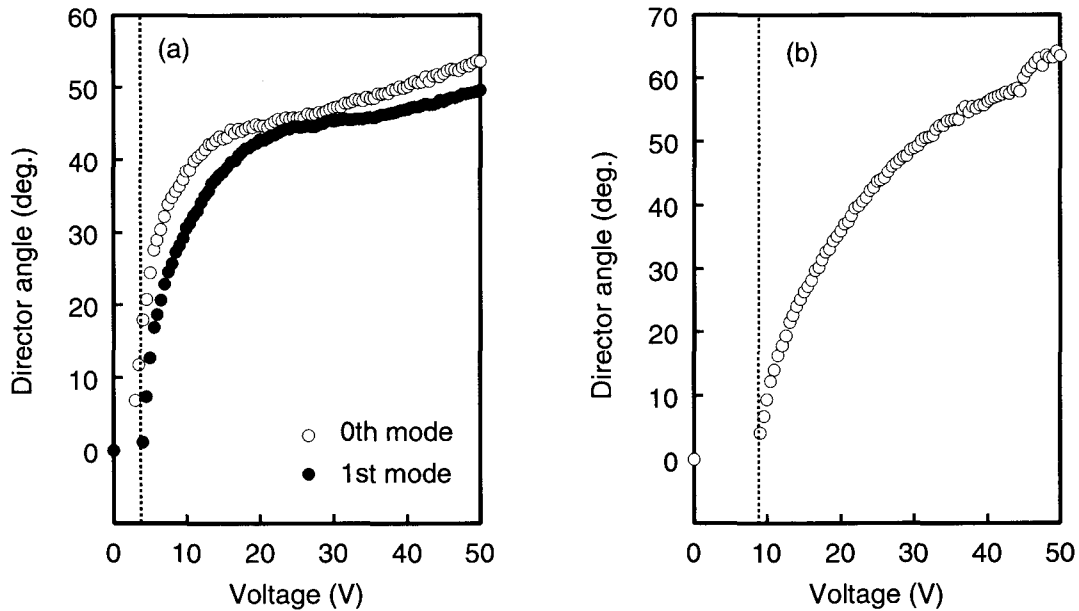

Fig.4 Applied voltage dependences of director angle of (a) SH wave and (b) Lamb wave.

The applied voltage dependences of the director orientation in the liquid-crystal cell are evaluated under different two types of elastic wave propagation. The variable penetration depth of the SH wave would be realized by using a SH wave device with its higher operation frequency. The use of the two kinds of wave, Lamb and SH waves, would be useful for clarifying the profile of the director orientation in the liquid-crystal cell. The present technique has the advantage of evaluating the liquid-crystal director angle without using a complicated experimental setup.

## References

- [1] H. Mada, J. Chem. Phys. **75** (1981) 372.
- [2] H. Yokoyama, Mol. Cryst. Liq. Cryst. **165** (1988) 265.
- [3] J. C. Dubois, M. Gazard and A. Zann, J. Appl. Phys. **47** (1976) 1270.
- [4] M. B. Feller, W. Chen and Y. R. Shen, Phys. Rev. A. **43** (1991) 6778.
- [5] S. Okutani, M. Kimura and T. Akahane, Jpn. J. Appl. Phys. **37** (1998) L600.
- [6] J. S. Foster and J. E. Frommer, Nature, **333** (1988) 542.
- [7] L. D. Landau and E. M. Lifshitz, *Fluid mechanics* (Pergamon, London), (1959).