



Title	Comparative Studies on Trypomastigotes of Trypanosoma cruzi from Infected Mouse Blood and Infected Fibroblast Cell (L-Cell) Culture
Author(s)	Kanbara, Hiroji; Nakabayashi, Toshio
Citation	Biken journal : journal of Research Institute for Microbial Diseases. 1983, 26(1), p. 57-62
Version Type	VoR
URL	https://doi.org/10.18910/82471
rights	
Note	

The University of Osaka Institutional Knowledge Archive : OUKA

<https://ir.library.osaka-u.ac.jp/>

The University of Osaka

COMPARATIVE STUDIES ON TRYPOMASTIGOTES OF *TRYPANOSOMA CRUZI* FROM INFECTED MOUSE BLOOD AND INFECTED FIBROBLAST CELL (L-CELL) CULTURE

HIROJI KANBARA and TOSHIO NAKABAYASHI

Department of Protozoology, Research Institute for Microbial Diseases, Osaka University,
Yamadaoka 3-1, Suita, Osaka 565, Japan

(Received November 6, 1982)

SUMMARY The resistance to phagocytosis by macrophages and the penetration into fibroblast cells of blood form trypomastigotes of *Trypanosoma cruzi* were compared with those of trypomastigotes grown in fibroblast cell culture. On incubation for 24 h, blood form trypomastigotes were almost completely resistant to phagocytosis, but about 40% of the trypomastigotes from cell culture were phagocytized. On longer incubation, the resistance of both forms of trypomastigotes decreased gradually. The penetrating ability of blood form trypomastigotes was much lower than that of trypomastigotes from cell culture. Infection of mice with blood form trypomastigotes resulted in less proliferation of parasites in the liver and spleen than that with trypomastigotes from cell culture. From these results, the existence of two functionally different forms of trypomastigotes in infected mice and in infected fibroblast cell culture, respectively, is discussed.

INTRODUCTION

Trypanosoma cruzi develops functionally by changing form according to the surrounding conditions. Recently, Nogueira et al. (1980) pointed out that blood form trypomastigotes can resist ingestion by mouse macrophages, while metacyclic trypomastigotes in culture are readily ingested by resident mouse macrophages. This observation led him to find that blood form trypomastigotes possess a specific surface glycoprotein that was readily removed by trypsin treatment (Nogueira et al. 1981). These results suggest that trypomastigote forms of *T. cruzi* have different characters in different conditions. *Trypanosoma brucei* has

two blood form trypomastigotes, stumpy and slender forms, the stumpy ones having well developed mitochondria that may enable them to adapt to growth in insects (Brown et al. 1973). This fact suggested that there may be two functional types of trypomastigotes of *T. cruzi* in infected animals: one that can rapidly penetrate into a neighboring cell after leaving a destroyed cell, and the other that can resist ingestion by leukocytes including macrophages but which may have low penetrative ability, and so remain in the blood stream. To test this idea, we compared the resistance to macrophages and the ability to penetrate fibroblast

cells (L-cells) of blood form trypomastigotes and trypomastigotes grown in fibroblast cell culture, which on heavy infection were considered to consist of both types.

MATERIALS AND METHODS

1. Parasite

The Tulahuen strain of *T. cruzi*, obtained in 1971 from the National Institute of Health, USA, through Keio University, Japan, and subsequently maintained in mice, was used.

1) Blood form trypomastigotes

Blood was collected from mice (C3H) on day 10 of infection in 5 volumes of MEM containing 10 U/ml of heparin. The sample was centrifuged at 250 *g* for 5 min and the supernate was recentrifuged at 250 *g* for 5 min. This procedure was repeated to remove as many red cells as possible. The final supernate was centrifuged at 1,300 *g* for 10 min, and the precipitate was dispersed in MEM medium.

2) Trypomastigotes in fibroblast cell culture

Blood form trypomastigotes were inoculated into a fibroblast cell (L-cell) culture and maintained in MEM medium with 10% calf serum at 37 C in a 5% -CO₂ incubator. When more than 80% of the fibroblast cells had been infected, the overlay medium containing trypomastigotes, amastigotes and fibroblast cell debris was collected. Trypomastigotes were separated on a CM-cellulose column (Kanbara and Nakabayashi 1983). The trypomastigotes used in the present work were obtained from fibroblast cell cultures established within 3 months previously from infected mice.

2. Phagocytosis by peritoneal macrophages

1) Macrophage culture

C3H mice of 2-4 months old were used. Three days after intraperitoneal injection of 2.0 ml of 3% thioglycolate medium in distilled water, the mice were killed by cervical dislocation. Their peritoneum was exposed and rinsed twice with 5 ml of Hanks' solution containing penicillin (100 U/ml), streptomycin (100 µg/ml) and heparin (10 U/ml). The pooled fluid was centrifuged at 4 C and the precipitate was suspended in cold MEM with 10% calf serum supplemented with 10% conditioned medium from L-cell culture, which was used to keep macrophages active throughout the experiment

(Nozawa et al. 1980). Macrophages were separated from other cells by their adhesion to culture plates on incubation in a 5% -CO₂ incubator at 37 C for 2 h.

2) Numbers of infected macrophages and of remaining trypomastigotes after incubation for 24 h.

Inocula of 8×10^5 macrophages were cultivated in wells (about 2.0 cm²) of a tissue culture multi-well plate (Flow Laboratories Inc.) with a cover slip at the bottom. About the same number (7×10^5) of trypomastigotes from different sources were inoculated into each well and the plates were incubated in a 5% -CO₂ incubator at 37 C. After 24 h, the cover slip was taken out, washed with saline, dried, fixed in methanol, stained with Giemsa and examined under a light microscope. The number of remaining trypomastigotes in the overlay medium was also counted. This experiment showed that the number of infected macrophages was inversely proportional to the number of remaining trypomastigotes. Therefore, in subsequent experiments, 5×10^5 to 5×10^7 trypomastigotes from different sources were inoculated into macrophage cell cultures in tissue culture dishes (100 × 20 mm style, Falcon 3003), and only the numbers of trypomastigotes remaining after incubation for 24 h were counted.

3) Maintenance of resistance to macrophages

Samples of 2×10^7 trypomastigotes from mouse blood and fibroblast cell culture, respectively, were inoculated into macrophage cultures and after incubation for 24 h, the remaining trypomastigotes were collected by centrifugation at 1,300 *g* for 10 min. The cell number was counted and then the harvested cells were again inoculated into new macrophage cultures. This procedure was repeated every 24 h or 48 h for 6 days.

3. Penetration of fibroblast cells (L-cells)

1) Numbers of infected fibroblasts and of remaining trypomastigotes after 24 h.

Fibroblast cells were cultured in MEM medium with 10% calf serum and then transferred to wells of a tissue culture multi-well plate and to tissue culture dishes (100 × 20 mm). The subsequent procedure was the same as in the experiment on macrophage phagocytosis.

4. Infection to mice

Inocula of 5×10^6 trypomastigotes from mouse blood and fibroblast cell culture were injected intraperitoneally into mice (C3H, 2-4 months), and 3

days later the mice were killed by bleeding. Their liver, spleen, heart, parts of the intestine, lungs and abdominal muscles were taken out, washed in Hanks' solution with 10 U/ml of heparin and minced with scissors. The respective minced tissues were dispersed in Hanks' solution with 10 U/ml of heparin, homogenized with a Teflon homogenizer and centrifuged at 80 g for 5 min to remove large debris. The upper layer (supernate) was collected, layered on a Ficoll-Conray column (specific gravity 1.095) and centrifuged at 1,300 g for 60 min. The interface layer on the Ficoll-Conray column was collected, dispersed in saline and centrifuged at 1,300 g for 10 min. The precipitate was suspended in a suitable volume of saline to make a total volume of 1 ml. One drop of the suspension was spread as a square (25 × 50 mm) on a slide glass, dried, fixed in methanol and stained with Giemsa, and the number of parasites in a suitable sized field was counted. Numbers were calculated as percentages of the maximum number counted in a sample of liver from mice infected with trypomastigotes from fibroblast cell culture.

RESULTS

After incubation for 24 h, most blood form trypomastigotes ($96.4 \pm 2.79\%$) remained in the overlay medium without being phagocytized, and so only 1.0% of the macrophages were infected. In contrast, only about half the trypomastigotes from the fibroblast cell culture ($56.8 \pm 10.5\%$) remained in the medium and about 30% of the macrophages were infected (Fig. 1). The subsequent developments of trypomastigotes from the two sources in macrophages were similar. The number of remaining trypomastigotes decreased gradually during further incubation: After 7 days about 60% of the blood form trypomastigotes remained in the medium (Fig. 2), while after 6 days 25% of those from fibroblast cell cultures still remained. When trypomastigotes from the two sources were inoculated into fibroblast cell cultures, the differences in the percentages of remaining trypomastigotes and of infected fibroblasts were not so marked as in macrophage cultures (Fig. 3), but nevertheless, results showed clearly that trypomastigotes from

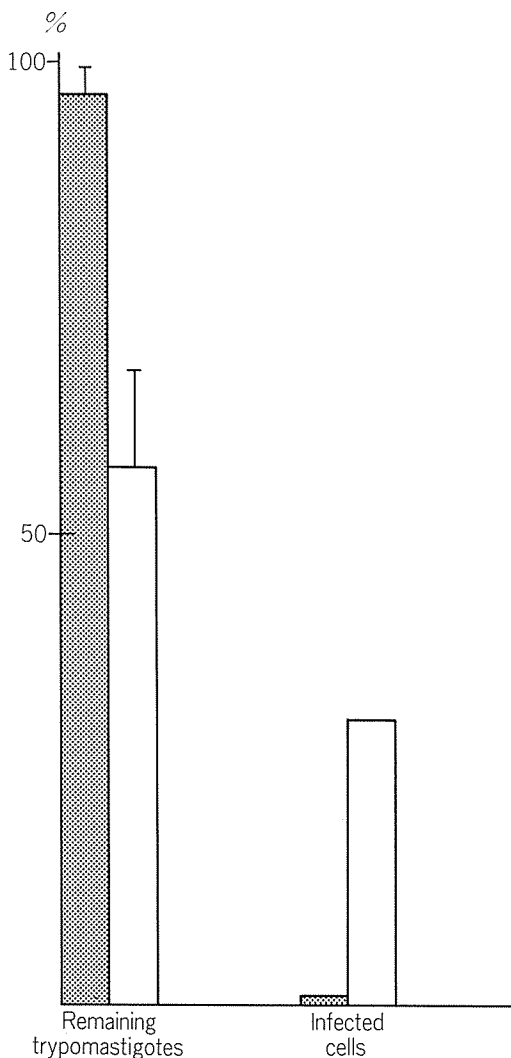

FIGURE 1. Percentages of remaining trypomastigotes and of infected macrophages 24 h after inoculation of blood form trypomastigotes (■) and trypomastigotes from fibroblast cell cultures (□) into macrophage cell cultures.

fibroblast cell culture had much stronger penetrating ability than blood form trypomastigotes. On infection of mice, trypomastigotes from both sources tended to migrate to the reticuloendothelial system (Fig. 4), because most of the parasites, which were transformed and

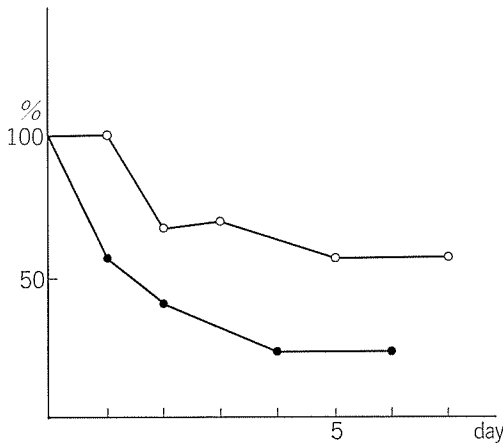

FIGURE 2. Changes with time in the percentage of remaining trypomastigotes. Trypomastigotes from mouse blood (○—○) and fibroblast cell cultures (●—●) were inoculated into macrophage cultures. Remaining trypomastigotes were collected from the overlay medium, counted and transferred to new macrophage cultures every 24 h or 48 h.

proliferated as amastigotes, were found in the liver and spleen. About four times more parasites were found in the liver and spleen of mice infected with trypomastigotes from fibroblast cell culture than in those infected with blood form trypomastigotes. This result indicated that trypomastigotes from cell culture penetrated cells more rapidly than blood form trypomastigotes and had as much virulence as the latter.

DISCUSSION

In trypanosomes of the brucei group, two functionally and morphologically different blood forms are found (Brown et al. 1973). Blood form trypomastigotes of *T. cruzi* have been used for studies on the interaction between trypomastigotes and macrophages (Alcantara and Brener 1980, Kipnis et al. 1979, Milder and Kloetzel 1980, Zenian and Kierszenbaum 1982). Recently, however, Nogueira et al. (1980) pointed out that blood form trypomastigotes are resistant to phagocytosis by

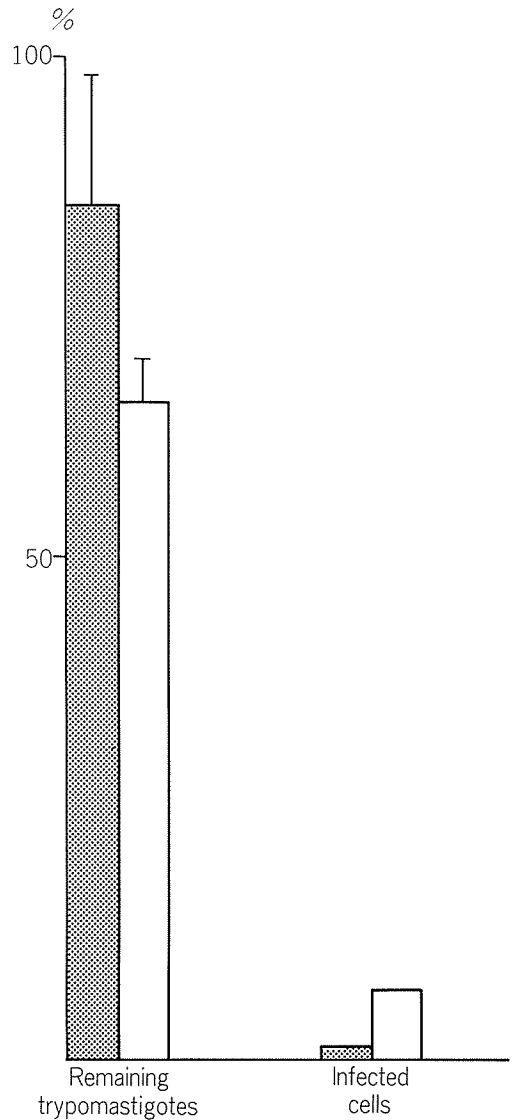

FIGURE 3. Percentages of remaining trypomastigotes and of infected fibroblast cells 24 h after inoculation of trypomastigotes from mouse blood (■) and fibroblast cell cultures (□) into fibroblast cell cultures.

mouse macrophages, whereas metacyclic trypomastigotes in culture were readily ingested. Blood form trypomastigotes of the Tulahuen strain maintained in our laboratory also showed

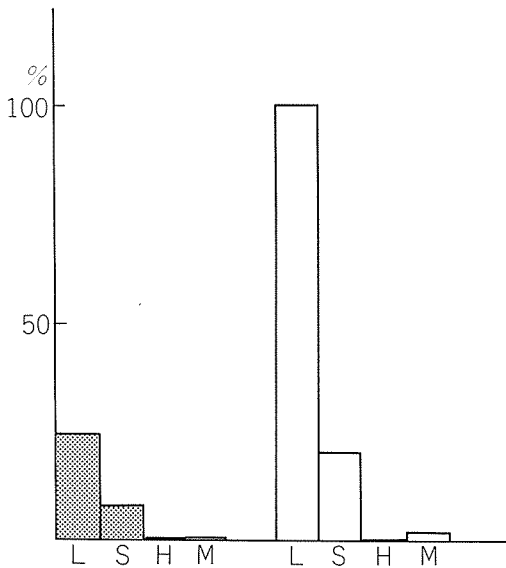

FIGURE 4. Comparison of parasite densities in various organs of mice infected 3 days previously with trypanosomes from blood (stippled) and fibroblast cell cultures (white). Values are percentages of the maximum density in the liver of mice infected with trypanosomes from fibroblast cell cultures. L: liver, S: spleen, H: heart, M: abdominal muscle.

the same character. Therefore, the question arose of why if amastigotes developed into blood form trypanosomes before entering new cells, parasitemia of infected mice was so low in spite of the existence of numerous amastigotes in the liver and spleen. In fact, numerous trypanosomes developed in fibroblast cell culture after heavy infection. Therefore, we wondered whether there could be two functional types of trypanosomes in infected mice: one that could penetrate host cells rapidly and that was readily ingested by macrophages, and the other that was resistant to phagocytosis but had low ability to penetrate host cells. If this was so, the former should be found with the latter in fibroblast cell culture, especially after heavy infection, but should not be found in the blood stream, while the latter should be present almost exclusively in the blood stream. The results of the present

experiments (Fig. 1, 2, 3) strongly support this idea. Blood form trypanosomes remained resistant to phagocytosis by macrophages for at least 24 h in culture. Moreover, about 25% of the trypanosomes from fibroblast cell culture were not ingested by macrophages in 6 days, and therefore more than 25% of the trypanosomes from cell culture may be considered to possess the same character as blood form trypanosomes. The ability of blood form trypanosomes to penetrate fibroblast cells varied considerably in different experiments from 71% to 99% for some unknown reason. An experiment on infection (Fig. 4) also confirmed that trypanosomes from cell culture were more rapidly ingested (or penetrated cells actively), and consequently proliferated more rapidly in the liver and spleen. Trypanosomes from both sources tended to migrate to organs rich in reticuloendothelial system such as the liver and spleen, probably because of the character of the Tulahuén strain. Although the metacyclic trypanosomes were less virulent than blood form trypanosomes (Nogueira et al. 1980), trypanosomes from cell culture appeared to be rather more virulent than blood form trypanosomes because of their more rapid entrance into host cells. Accordingly, the resistance to macrophage phagocytosis does not seem to be related to the virulence. To avoid the effect of fibroblast cells, we minced tissue of the spleen, heart and muscle from mice 8 days after infection and cultured the tissue in MEM with 10% calf serum at 37 C in a 5%-CO₂ incubator. The trypanosomes that developed showed the same character as trypanosomes from fibroblast cell culture. To examine the effect of mouse serum, we incubated trypanosomes from cell cultures in mouse serum for one hour but found that the serum had no effect. Further studies are required on the surface characters and especially the site of attachment of trypanosomes to host cells for penetration to determine the reason for the difference between the two functional types.

REFERENCES

- Alcantara, A., Brener, Z. 1980. *Trypanosoma cruzi*: Role of macrophage membrane components in the phagocytosis of bloodstream forms. *Exp. Parasitol.* 50: 1-6.
- Brown, R. C., Evans, D. A., Vickerman, K. 1973. Changes in oxidative metabolism and ultrastructure accompanying differentiation of the mitochondrion in *Trypanosoma brucei*. *Int. J. Parasitol.* 3: 691-704.
- Kanbara, H., Nakabayashi, T. 1983. Improved method for separation on CM-cellulose of the trypomastigote form of *Trypanosoma cruzi* from forms grown in fibroblast cell culture. *Biken J.* 26: 63-65.
- Kipnis, T. L., Galich, V.L.G., da Silva, W. Dias. 1979. Active entry of bloodstream forms of *Trypanosoma cruzi* into macrophages. *Parasitology* 78: 89-98.
- Milder, R., Kloetzel, J. 1980. The development of *Trypanosoma cruzi* in macrophages in vitro. Interaction with lysosomes and host cell fate. *Parasitology* 80: 139-145.
- Nogueira, N., Chaplan, S., Cohn, Z. 1980. *Trypanosoma cruzi*: Factors modifying ingestion and fate of blood form trypomastigotes. *J. Exp. Med.* 152: 447-451.
- Nogueira, N., Chaplan, S., Tydings, J. D., Unkeless, J., Cohn, Z. 1981. *Trypanosoma cruzi*: Surface antigens of blood and culture forms. *J. Exp. Med.* 153: 629-639.
- Nozawa, R. T., Sekiguchi, R., Yokota, T. 1980. Stimulation by conditioned medium of L-929 fibroblasts, *E. coli* lipopolysaccharide, and muramyl dipeptide of candidacidal activity of mouse macrophages. *Cell. Immunol.* 53: 116-124.
- Zenian, A., Kierszenbaum, F. 1982. Inhibition of macrophage-*Trypanosoma cruzi* interaction by concanavalin A and differential binding of bloodstream and culture forms to the macrophage surface. *J. Parasitol.* 68: 408-415.